

# AERIAL

## ADVENTURE GUIDE

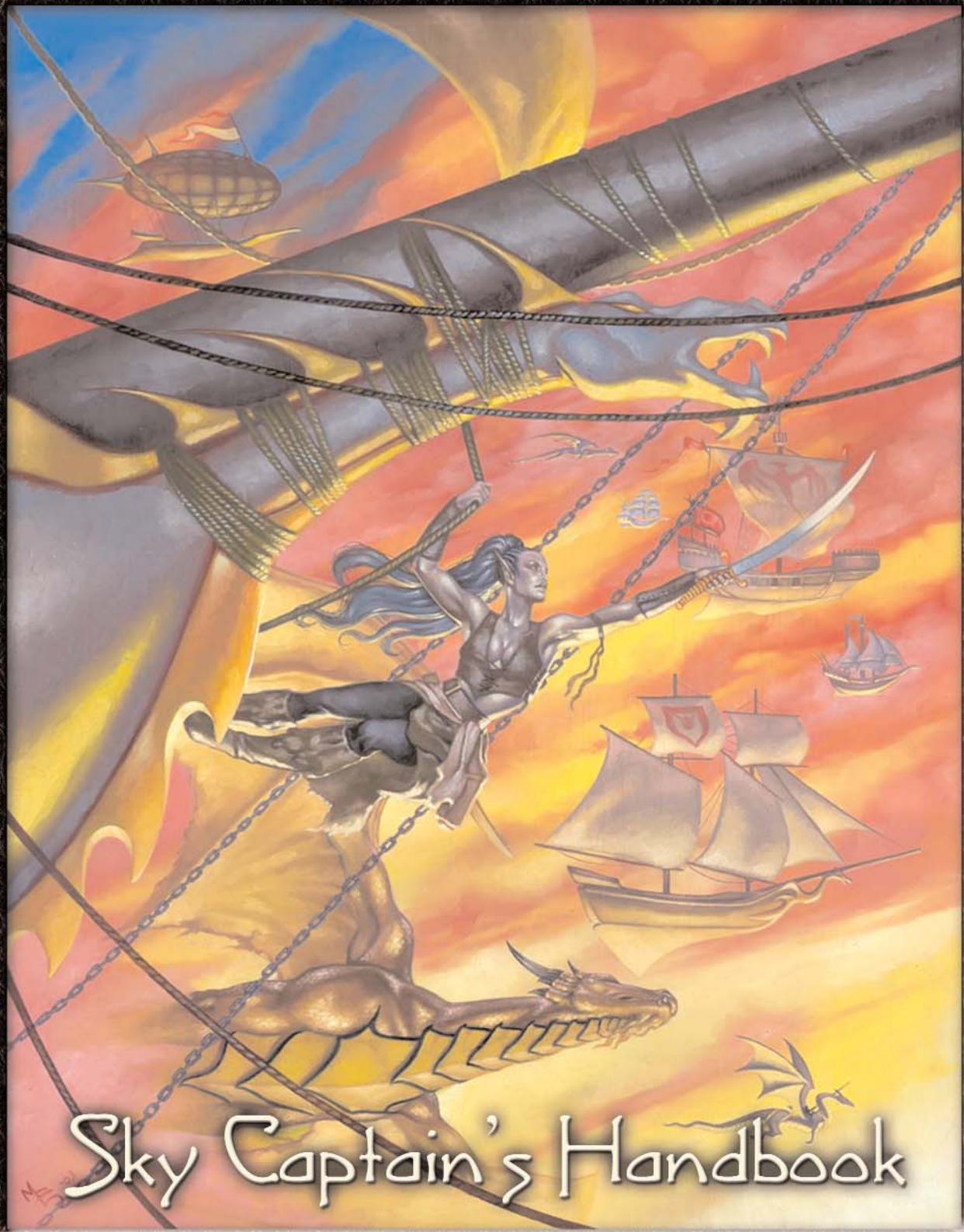

Sky Captain's Handbook



*Sky Elf Airhawk*  
LOA- 60ft.  
Beam- 20ft.

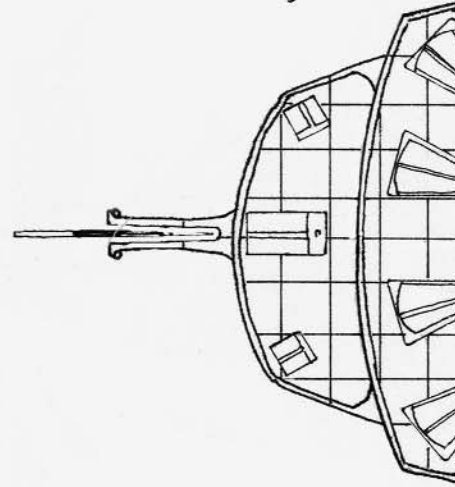
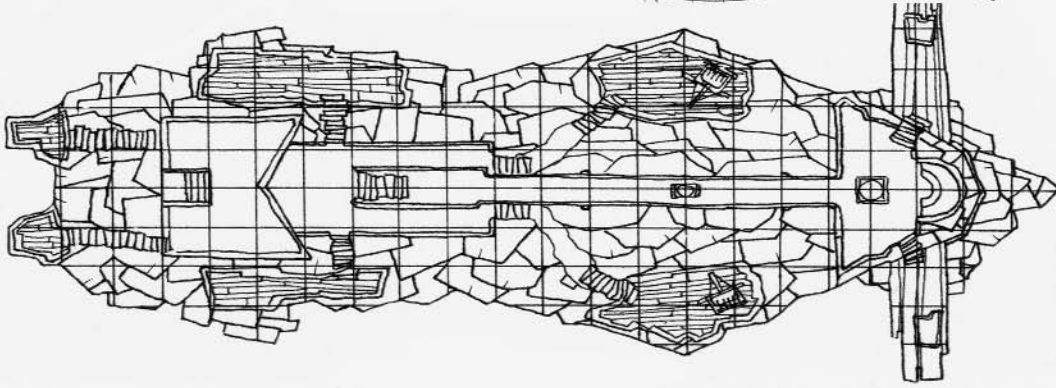
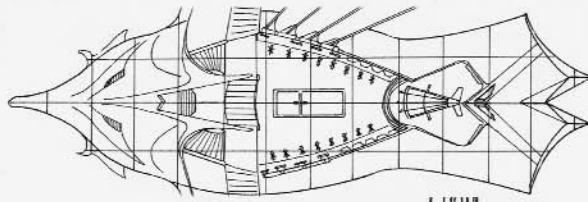

*rc Junkheap* LOA- 120ft Beam- 40ft

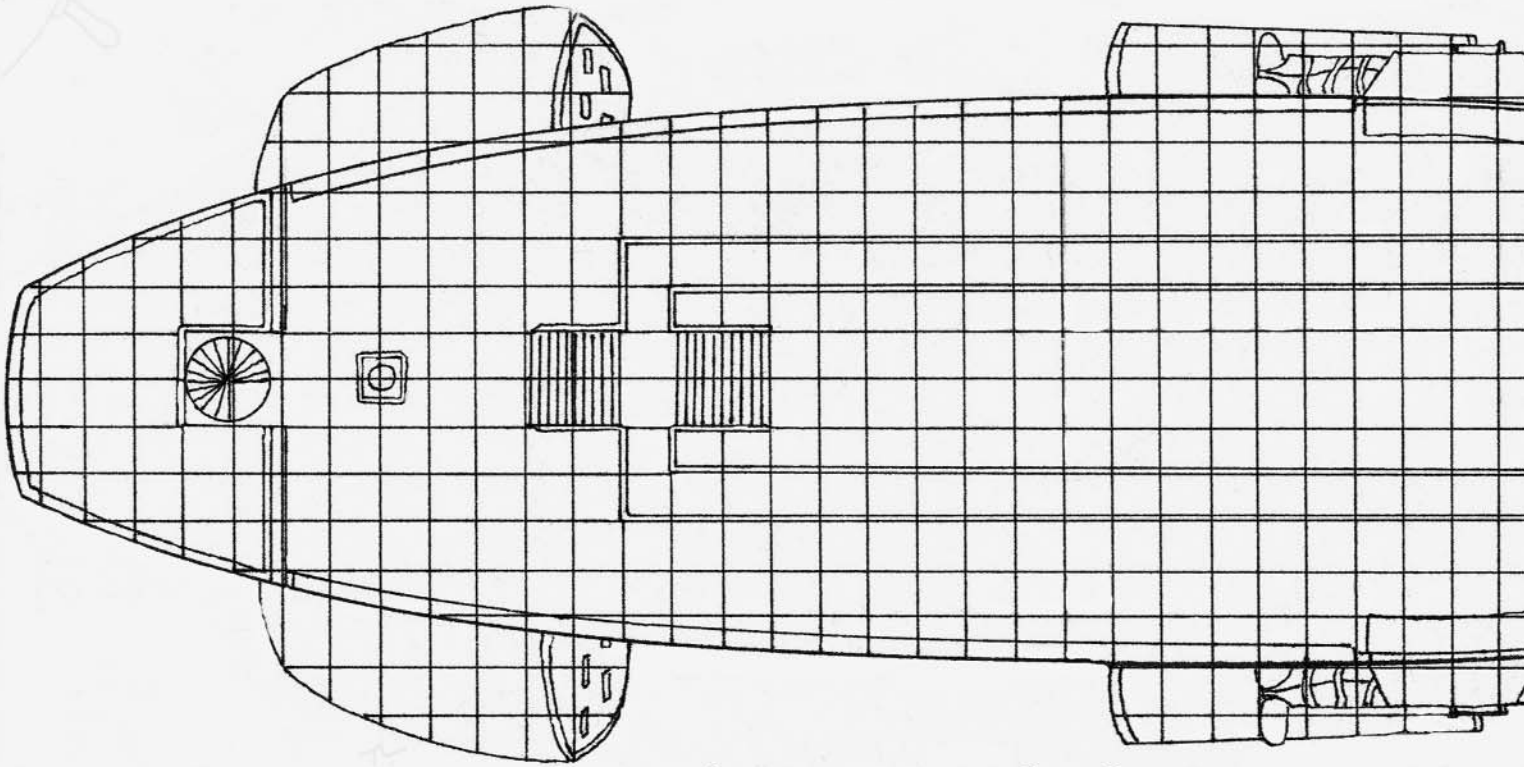

*Sky Elf Parhawk* LOA- 240ft. Beam

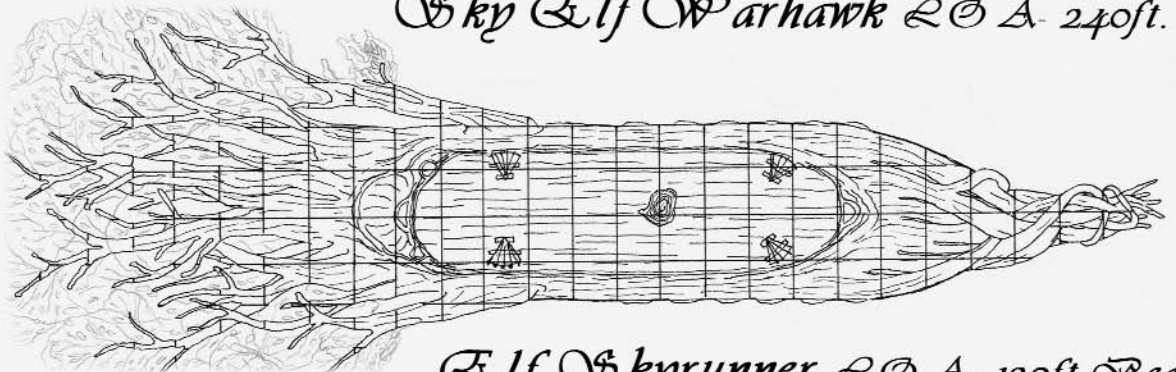

*Elf Skyrunner* LOA- 120ft Beam- 40ft

© verlord & eppelin 20 A- 180ft Beam- 60ft

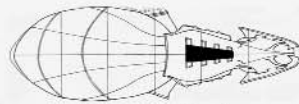
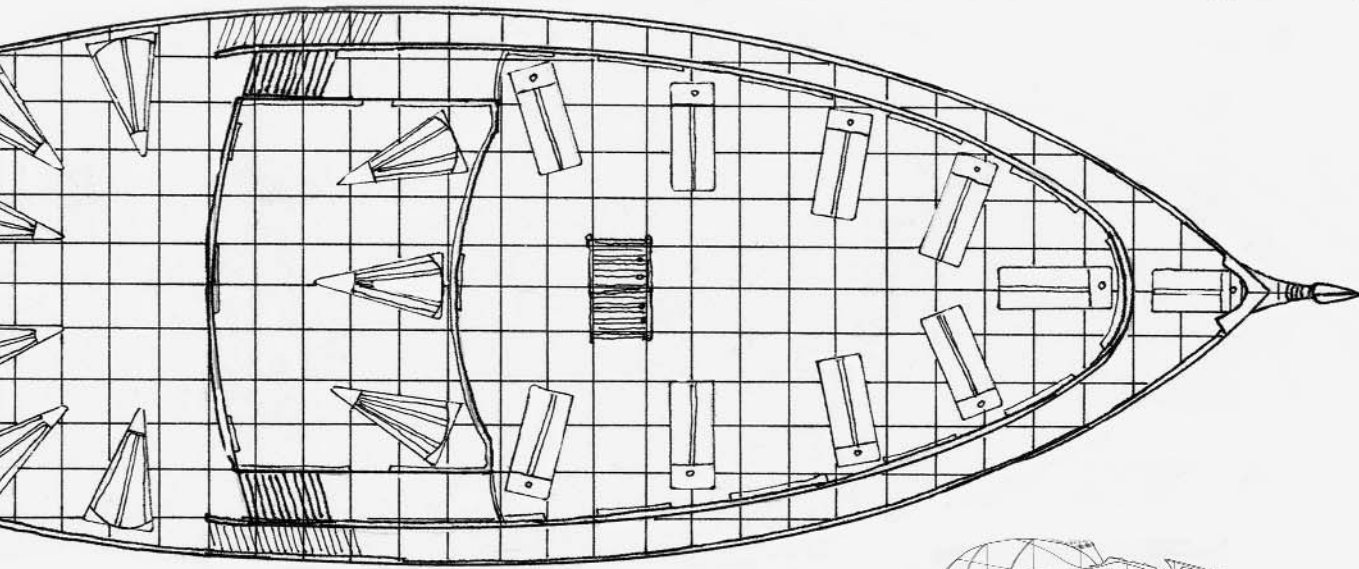

Arachial Spinner  
 20 A- 30ft.  
 Beam- 10ft.

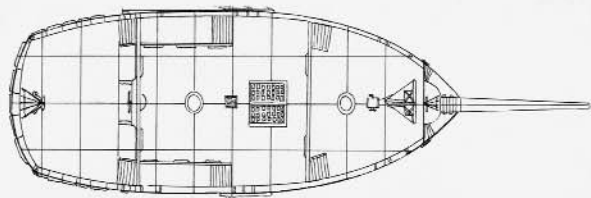
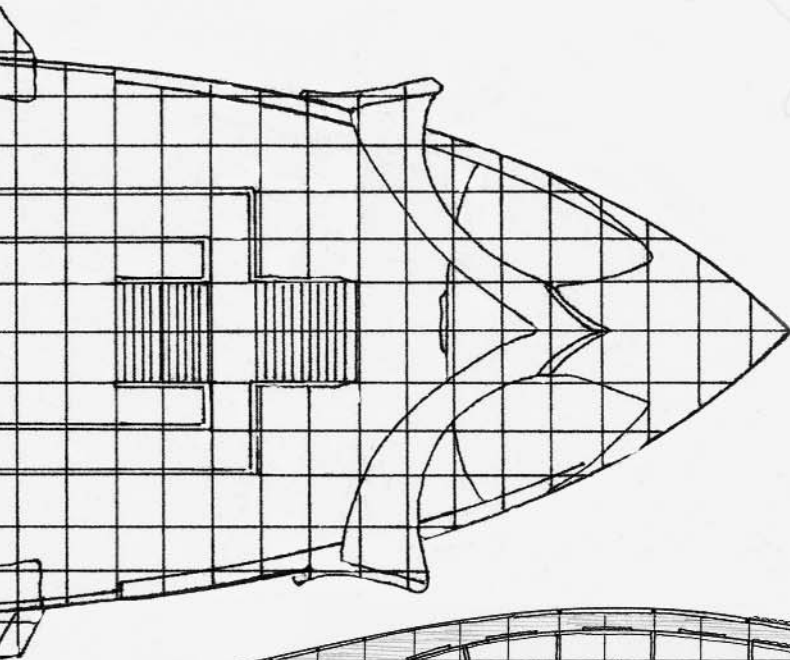

Javelin  
 20 A- 60ft  
 Beam- 20ft

n- 80ft

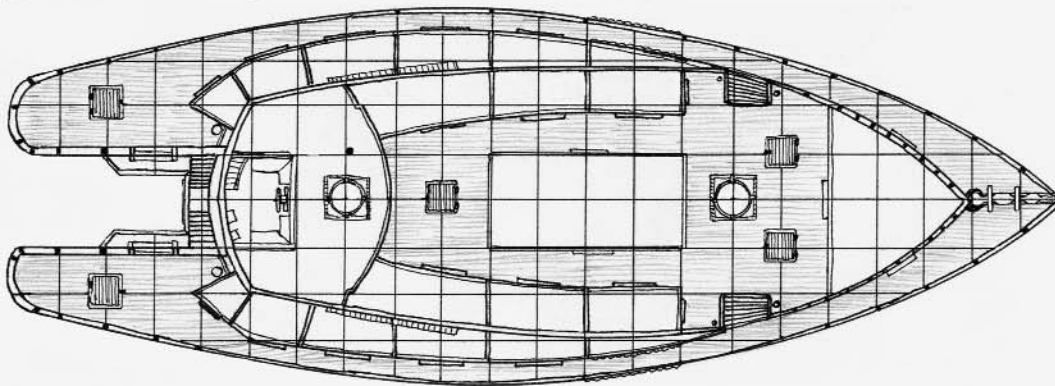

Scow  
 20 A- 120ft.  
 Beam- 40ft.

ft

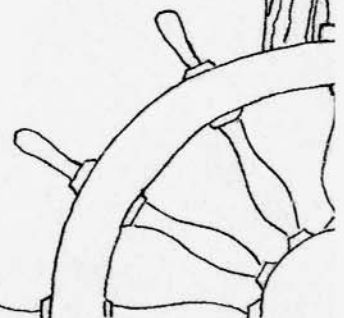



# Aerial Adventure Guide

Written by Michael Mearls

Additional writing by Timothy Grubbs (arachial feats),  
Gunnar Hultgren (khasri, limmer gaff, and weather bane),  
and Jon Pollom (ombosi, skowerlith, and zephyrghost)

Development and additional writing by Joseph Goodman

Cover art by Michael Erickson

Cover design by Andy Hopp

Interior art by Carlos Henry, William McAusland, and V. Shane

Deck plans by Clayton Bunce

Cartography by Matt Snyder

Editing and interior design by Joseph Goodman

Proofreading by John Thompson

Rules commentary by Matthew Mosher



Published by Goodman Games – [goodmangames@mindspring.com](mailto:goodmangames@mindspring.com)  
Visit [www.goodman-games.com](http://www.goodman-games.com) for freebies, message boards, web exclusives, and more!





This printing of *Aerial Adventure Guide: Sky Captain's Handbook* is done under version 1.0 of the Open Gaming License, version 5 of the D20 System Trademark License, version 4 of the D20 System Trademark Logo Guide, and the System Reference Document by permission from Wizards of the Coast, Inc. Subsequent printings will incorporate final versions of the license, guide and document.

**Designation of Product Identity:** The following items are hereby designated as Product Identity in accordance with Section 1(e) of the Open Game License, version 1.0: Any and all *Aerial Adventure Guide* logos and identifying marks and trade dress; the terms *Aerial Adventure Guide*, *avian*, *arachial*, *elemental convert*, *sky elf*, *Sellaine*, *Jewel of the Clouds*, *air knight*, *sky elf battle captain*, *Dreadfall*, *Fulgash's Tower*, *The Wildlands*, *The Derelicts*, *Captain Lebeyewyn*, *The Quest*, *The Sage of Air*, *Noctilius Point*, *cloud colony*, *cloud lurker*, *sky fiend devil*, *floating polyp*, *flutter ray*, *khasri*, *limmer gaff*, *ombosi*, *plague vulture*, *rain sprite*, *skaedrim*, *skowerlith*, *Velda's mournful whippoowill*, *weather bane*, and *zephyrhast*, as well as all monster names, character names, NPC names, proper nouns, capitalized terms, italicized terms, artwork, maps, symbols, depictions, and illustrations, except such elements that already appear in the System Reference Document.

**Designation of Open Content:** Subject to the Product Identity designation above, the following sections are designated as Open Gaming Content: all creature statistics, starting with the line "Hit Dice" and concluding with the line "Level Adjustment"; the entire text of the "Equipment of the Skies" section from pages 29-35; the entire text of the "Feats" section from pages 23-28; and the "Trade Goods" table on page 128, except for such terms as are designated Product Identity. In addition, all text in this typeface is open content. No art, illustrations, or graphic elements are open game content.

Some of the portions of this book which are delineated OGC originate from the System Reference Document and are copyright © 1999, 2000 Wizards of the Coast, Inc. The remainder of these OGC portions of these book are hereby added to Open Game Content and, if so used, should bear the COPYRIGHT NOTICE "*Aerial Adventure Guide: Sky Captain's Handbook*, by Michael Mearls, Copyright 2004 Goodman Games (contact [goodmangames@mindspring.com](mailto:goodmangames@mindspring.com), or see [www.goodman-games.com](http://www.goodman-games.com))"

*Aerial Adventure Guide: Sky Captain's Handbook* is copyright © 2004 Goodman Games.

*Dungeons & Dragons*® and *Wizards of the Coast*® are Registered Trademarks of Wizards of the Coast, and are used with Permission. Open game content may only be used under and in the terms of the Open Game License.

'd20 System' and the 'd20 System' logo are Trademarks owned by Wizards of the Coast and are used according to the terms of the d20 System License version 1.0. A copy of this license can be found at [www.wizards.com](http://www.wizards.com).

**OPEN GAME LICENSE Version 1.0a**

The following text is the property of Wizards of the Coast, Inc. and is Copyright 2000 Wizards of the Coast, Inc ("Wizards"). All Rights Reserved.

1. Definitions: (a) "Contributors" means the copyright and/or trademark owners who have contributed Open Game Content; (b) "Derivative Material" means copyrighted material including derivative works and translations (including into other computer languages), potation, modification, correction, addition, extension, upgrade, improvement, compilation, abridgment or other form in which an existing work may be recast, transformed or adapted; (c) "Distribute" means to reproduce, license, rent, lease, sell, broadcast, publicly display, transmit or otherwise distribute; (d) "Open Game Content" means the game mechanic and includes the methods, procedures, processes and routines to the extent such content does not embody the Product Identity and is an enhancement over the prior art and any additional content clearly identified as Open Game Content by the Contributor, and means any work covered by this License, including translations and derivative works under copyright law, but specifically excludes Product Identity. (e) "Product Identity" means product and product line names, logos and identifying marks including trade dress; artifacts; creatures characters; stories, storylines, plots, thematic elements, dialogue, incidents, language, artwork, symbols, designs, depictions, likenesses, formats, poses, concepts, themes and graphic, photographic and other visual or audio representations; names and descriptions of characters, spells, enchantments, personalities, teams, personas, likenesses and special abilities; places, locations, environments, creatures, equipment, magical or supernatural abilities or effects, logos, symbols, or graphic designs; and any other trademark or registered trademark clearly identified as Product identity by the owner of the Product Identity, and which specifically excludes the Open Game Content; (f) "Trademark" means the logos, names, mark, sign, motto, designs that are used by a Contributor to identify itself or its products or the associated products contributed to the Open Game License by the Contributor (g) "Use", "Used" or "Using" means to use, Distribute, copy, edit, format, modify, translate and otherwise create Derivative Material of Open Game Content. (h) "You" or "Your" means the licensee in terms of this agreement.

2. The License: This License applies to any Open Game Content that contains a notice indicating that the Open Game Content may only be Used under and in terms of this License. You must affix such a notice to any Open Game Content that you Use. No terms may be added to or subtracted from this License except as described by the License itself. No other terms or conditions may be applied to any Open Game Content distributed using this License.

3. Offer and Acceptance: By Using the Open Game Content You indicate Your acceptance of the terms of this License.

4. Grant and Consideration: In consideration for agreeing to use this License, the Contributors grant You a perpetual, worldwide, royalty-free, non-exclusive license with the exact terms of this License to Use, the Open Game Content.

5. Representation of Authority to Contribute: If You are contributing original material as Open Game Content, You represent that Your Contributions are Your original creation and/or You have sufficient rights to grant the rights conveyed by this License.

6. Notice of License Copyright: You must update the COPYRIGHT NOTICE portion of this License to include the exact text of the COPYRIGHT NOTICE of any Open Game Content You are copying, modifying or distributing, and You must add the title, the copyright date, and the copyright holder's name to the COPYRIGHT NOTICE of any original Open Game Content you Distribute.

7. Use of Product Identity: You agree not to Use any Product Identity, including as an indication as to compatibility, except as expressly licensed in another, independent Agreement with the owner of each element of that Product Identity. You agree not to indicate compatibility or co-adaptability with any Trademark or Registered Trademark in conjunction with a work containing Open Game Content except as expressly licensed in another, independent Agreement with the owner of such Trademark or Registered Trademark. The use of any Product Identity in Open Game Content does not constitute a challenge to the ownership of that Product Identity. The owner of any Product Identity used in Open Game Content shall retain all rights, title and interest in and to that Product Identity.

8. Identification: If you distribute Open Game Content You must clearly indicate which portions of the work that you are distributing are Open Game Content.

9. Updating the License: Wizards or its designated Agents may publish updated versions of this License. You may use any authorized version of this License to copy, modify and distribute any Open Game Content originally distributed under any version of this License.

10. Copy of this License: You MUST include a copy of this License with every copy of the Open Game Content You Distribute.

11. Use of Contributor Credits: You may not market or advertise the Open Game Content using the name of any Contributor unless You have written permission from the Contributor to do so.

12. Inability to Comply: If it is impossible for You to comply with any of the terms of this License with respect to some or all of the Open Game Content due to statute, judicial order, or governmental regulation then You may not Use any Open Game Material so affected.

13. Termination: This License will terminate automatically if You fail to comply with all terms herein and fail to cure such breach within 30 days of becoming aware of the breach. All sublicenses shall survive the termination of this License.

14. Reformation: If any provision of this License is held to be unenforceable, such provision shall be reformed only to the extent necessary to make it enforceable.

**15 COPYRIGHT NOTICE**

**Open Game License v 1.0** Copyright 2000, Wizards of the Coast, Inc.

**System Rules Document** Copyright 2000 Wizards of the Coast, Inc.; Authors Jonathan Tweet, Monte Cook, Skip Williams, based on original material by E. Gary Gygax and Dave Arneson.

**Cloud Warriors**, Copyright 2003, Fast Forward Entertainment

**Airships**, Copyright 2003, Bastion Press, Inc.

**Aerial Adventure Guide: Sky Captain's Handbook**, by Michael Mearls, Copyright 2004 Goodman Games (contact [goodmangames@mindspring.com](mailto:goodmangames@mindspring.com), or [www.goodman-games.com](http://www.goodman-games.com))



# Table of Contents

Introduction .....	4	Cloud Lurker .....	83
Chapter One: Characters .....	8	Devil, Sky Fiend .....	84
New Races .....	8	Dire Hawk .....	85
Arachial .....	8	Dragon, Star .....	86
Avian .....	10	Dragon, Wind .....	88
Sky Elf .....	11	Elf, Sky .....	90
Surface Races .....	13	Floating Polyp .....	91
Heroic Legacies .....	15	Flutter Ray .....	93
Character Classes .....	17	Golem, Mist .....	94
Prestige Classes .....	17	Infused, Air (Template) .....	95
Air Knight .....	17	Khasri .....	96
Elemental Convert .....	19	Leviathan .....	98
Sky Elf Battle Captain .....	21	Limmer Gaff .....	99
New Uses for Skills .....	22	Lycanthrope: Werhawk .....	100
Feats .....	23	Noctilius Bat .....	102
New Feats Table .....	24	Ombosi .....	104
Equipment .....	29	Plague Vulture .....	106
Chapter Two: Aerial Combat .....	36	Rain Sprite .....	107
Altitude .....	38	Skaerdrim .....	109
Weather .....	38	Skowerlith .....	111
Chapter Three: Sky Ships .....	41	Sky Sailors & Pirates (NPCs) .....	111
Sky Ship Combat .....	42	Sky Captain Traits .....	113
Designing Ships .....	44	Sky Serpent .....	114
Ship Templates .....	45	Thunder Cloud .....	115
Sample Ship Designs .....	49	Traders (NPCs) .....	116
Chapter Four: The Sky Realms .....	54	Velda's Mournful Whippoorwill .....	117
Sellaine, Jewel of the Clouds .....	54	Weather Bane .....	118
Other Locations .....	64	Winged Borer .....	119
Dreadfall .....	64	Winged Creature (Template) .....	119
Fulgash's Tower .....	68	Zephyrghast .....	121
The Wildlands .....	71	Chapter Six: Running Aerial Adventures .....	123
The Derelicts .....	73	Aerial Campaigns .....	123
Captain Lebeyewn Of <i>The Quest</i> .....	76	Types of Aerial Adventures .....	127
The Sage of Air .....	77	Exploration .....	127
The Black Orcs of Noctilius Point .....	78	Trade .....	128
Chapter Five: Denizens of the Sky .....	79	Diplomacy .....	130
Arachial .....	79	Conquest and Combat .....	131
Avian .....	81	Traveling in the Skies .....	132
Cloud Colony .....	82	Beyond the Clouds .....	134
		Sky Ship Record Sheet .....	135
		Sky Ship Deck Plans .....	136

Visit [www.goodman-games.com](http://www.goodman-games.com) for free web enhancements!



# Introduction

Picture in your mind the typical fantasy RPG campaign world. Don't draw your picture based on a map, or an image, or the climactic scene of a grand adventure. Instead, assume the eyes and ears of an ordinary peasant. Look around now, and see what that peasant sees. Perhaps this is a world of thick, lush forests and clear, azure skies. Maybe our peasant is a desert nomad who journeys across seemingly endless dunes of sand under a relentless, punishing sun. Or our peasant could be trapped in a dark world of vampires, werewolves, and worse. When the sun dips beneath the horizon and the moon takes to the sky, he had best find shelter. Regardless of the world around him when our peasant looks up he sees the sky, be it a clear, bright blue sky or a foreboding stretch of dark clouds.

In most fantasy games, the action and adventure take place far from the sun's reach. Heroes delve into ancient ruins, lost dwarf citadels, and caverns tucked deep within the earth. The sun is a welcome sight that heralds an adventure's end and a return to the comfort of civilization.

Or is it?

In a world rich in magic, strange beasts, and gods that walk the earth, it is within the realm of possibility that when our theoretical peasant looks up into the sky he gazes upon a distant realm of wonder. Just as a short distance beneath his feet an epic war between dwarves and orcs may rage through the pitch black passages of the underworld, perhaps far above his head a small fleet of flying ships soars through the sky, rising into the air to challenge an approaching flight of marauding wyverns. If adventure can be found below, why not above?

Welcome to a world of fantasy adventure that has quite literally been hanging over your campaign's head for years. Flying ships and wondrous castles floating amongst the clouds have long been a staple of fantasy. The fairy tale Jack and the Beanstalk features a castle perched high in the sky, while classic fantasy epics such as Tolkien's *Lord of the Rings* include intelligent flying races like the great eagles. In a world where magic makes almost anything possible, perhaps an industrious race of powerful magicians could take to the sky and settle there permanently, free of the trials and tribulations of life on the surface. Of course, this being a game of fantastic adventure, life in the sky comes with its own set of challenges, villains, and fearsome monsters.

This book posits a simple idea: what if in your campaign world some of the clouds that drift overhead harbor small cities, villages, ruins, castles, and other settlements? What sort of creatures would live up there? What kind of cloud islands could you encounter? How do creatures travel? Do they interact with the surface world?

This introductory chapter provides some guidelines to answering those questions and maps out some basic ideas for what a cloud realm may look like.

Chapter 1 provides character options for adventures in

the sky. It introduces three races that dwell amongst the clouds: the sky elves, the evil arachial, and the barbaric avians. In addition, it showcases heroic legacies that allow other races to find aerial adventure, describes three prestige classes native to air dwellers, and introduces new feats and equipment.

Chapter 2 includes expanded rules for aerial combat, allowing you to fight battles in the sky with ease.

Chapter 3 gives rules for sky ships, vessels much like sailing ships that soar through the sky and provide the primary means of transportation in the aerial realms for wingless creatures.

Chapter 4 describes the many interesting locations to be found in the sky realms, including the sky elf city of Sellaine.

And of course, no adventuring environment would be complete without a few monsters to threaten the heroes. Chapter 5 introduces a variety of new monsters that are appropriate to an aerial realm.

Chapter 6 offers guidelines and inspiration for running an aerial campaign, complete with ideas and rules for trade expeditions and diplomatic missions. Finally, there are deck plans for eight of the most popular sky ship designs.

So, strap on your *wings of flying*, board the waiting Warhawk sky ship, and prepare to explore a new vista of adventure.

## The Sky Realms

Far above the daily bustle of life, there floats a completely separate realm atop some of the seemingly innocent clouds that drift through the sky. At the highest points of the atmosphere, dimensional rifts shunt energy to and from the elemental plane of air. Occasionally, the diaphanous cloud materials of the elemental realm drift through a gate. While these masses appear to be normal clouds, they are in fact durable bodies of solid material. In the elemental plane, they serve as floating islands upon which civilizations grow and prosper. From the bottom, they look like puffy, white clouds. Anyone viewing them from above can see the thick layer of soil and the small, stunted forests that grow upon them. Within these verdant realms, wild animals, humanoids, and other creatures can grow and flourish. Fed by light rain from even higher clouds and the moist winds that sweep over them, cloud realms are viable homes for most creatures.

Solid clouds are rare in most worlds of the prime material plane. The typical barony may see one drift overhead once every decade. However, in some worlds these formations are much more common, particularly those that are tightly bound to the elemental plane of air. In these realms, a full 10% of clouds are capable of sustaining life on their upper sides.

In worlds where cloud realms are common, flying races



colonize them. Creatures such as wyverns nest amongst the clouds, as do griffons and sphinxes. Dragons who wish to be alone with their hordes find a suitable cloud realm, burrow a small cave or other shelter into its center, and rest there for years free of bother from crusading knights, greedy thieves, and other pests.

Cloud realms truly come into their own when intelligent humanoids tend to them. Sleek flying ships crafted by the sky elves soar through the air, glinting in the sun as they approach to land at a sky town's docks. Brave adventurers assemble valiant crews to sail across the sky in search of undiscovered cloud realms that may hold alien civilizations, forgotten treasure caches, and terrible monsters. Enterprising halflings use magic and perhaps a "liberated" sky ship to establish trade between the clouds and the surface. With a high level of magic, it is possible for the cloud realms to become as densely settled and as well traveled as the surface.

## Adding Cloud Realms to Your Campaign

As a default, this book presents three races that dwell almost exclusively amongst the clouds: the sky elves, the arachial, and the avians. All three races have little contact with the surface, as travel between the ground and the sky is rather limited. All are civilized to varying degrees, and all claim ownership to various cloud realms.

If you want to run a game where contact between earth and sky is not a common occurrence, then travel to the skies is incredibly rare. Few if any spellcasters possess the knowledge needed to construct a sky ship. Items such as *wings of flying* are too rare to make travel there possible for anyone aside from a few powerful individuals. The two realms are mostly ignorant of each other.

The default setting as presented here assumes that some travel takes place between the two regions but that travel is too difficult for lasting bonds to emerge. Sky ships are common amongst the clouds but almost unheard of on the surface. Sages and other learned people may know a bit about their opposite region, but many commoners on both sides consider the surface or the clouds to be mythical, mysterious realms. Of course, cloud dwellers are a bit less leery of the surface world as most have seen high mountains or caught a glimpse of the ground while traveling. Still, they consider it a place best avoided.

If you want a campaign where the sky realms are just another kingdom or region, then sky ships are common modes of transportation. Major cities may have docks set up in their harbors to serve ships that travel from above and drop anchor beside those that sail the ocean. In some places, air travel might eclipse ground movement or ocean voyages as the preferred method of transportation. Armies march to war with small flotillas of sky ships soaring overhead, ready to drop catapult and ballista fire upon their enemies.

Regardless of how you choose to introduce cloud realms into your campaign, it is best to remember that no change exists in a bubble. If a nation produces sky ships for trade, they also use them in war. If air travel is common, then trade takes place over long distances and brings far-flung kingdoms and empires into contact. Before rushing to integrate cloud realms into your game, be sure to carefully con-



sider the repercussions they may have. As a rule of thumb, it is best to stick with the first two options presented above unless you plan to run a sky campaign from the outset. Introducing these elements too quickly or on too large a scale into an existing world may cause you problems down the line. For more on this, see chapter 6.

## Designing Cloud Realms

A cloud realm can take on many shapes and forms. They can range from miles wide to no more than a hundred feet across. They can be thin and littered with holes that can drop an unwary traveler to the surface, or thick and honey-combed with passages and tunnels.

The bottom portion of a cloud realm is composed of thick, fibrous white material. The upper half on most is covered in a layer of moist, loamy soil capable of supporting plant life, though some cloud realms feature radically different terrain. Most clouds have a temperate environment, though they tend to mirror the climate of the area beneath them. When a cloud wanders to the polar regions, it becomes much colder and snowy. Over deserts it grows dry, while over the ocean it becomes wetter and warmer.

Clouds generally follow a predictable path over the course of a year. The high winds push them through the sky, giving them a regular turn of seasons and sometimes causing cloud realms to temporarily combine into one large mass. When two allied communities combine, they celebrate with festivals and holidays until their clouds part. If two rivals collide, the clouds are torn by war and skirmishes until they finally drift away.

## Cloud Communities

Generate cities, towns, and villages just as you would for a surface region. However, magic is much more common





amongst the clouds. On average, a cloud settlement's highest-level spellcaster is two levels higher than those found on the surface. Sky communities also have large, complex harnesses to catch and hold sky ships that dock there. Many sky ships are not maneuverable enough to hover; thus, they must have special landing cradles to hold them while they are in port.

Few communities bother with walls unless they are built on cloud realms where dangerous creatures wander the wilderness. Most towns feature a low stockade to impede attackers, but in the aerial realm, attacks from above are far more common. Thus, defensive fortifications tend to be spread throughout a town or village. The outer wall features guards and artillery designed to thwart ground attacks, while taller towers form successive, concentric rings within the settlement. These towers are manned by archers and ballistae to repel aerial assaults.

Most towns require approaching ships to move directly towards the town docks. Ships sailing above a settlement risk attack or serious fines. In the wilds of the sky, it is best to shoot first and apologize later rather than risk a pirate or archaic attack.

Buildings are normally built of wood and other organic materials. While trees and other plants flourish on clouds, stone and metal are both relatively rare. Sky elf military bases and their ancient, original cities are small, roofed colonies forged from iron, steel, and bronze. These wondrous colonies are few in number but provide a critical line of defense for the elf kingdoms. Many incursions against the elves have worn themselves thin with successive, futile assaults against these almost impregnable fortresses.

Sky elf cities are built on the premise of defense first and aesthetics second. Sky elf commoners learn to wield weapons and every adult is expected to respond to an alarm, ready to fight. The town guard in sky elf towns is renowned for its no-nonsense attitude. A few wrong words can get a surface-worlder or stranger thrown in the stocks.

Trading cities spring up whenever the surface and sky worlds cross paths. These cosmopolitan centers are run either by sky elves or by trading companies founded by a surface merchant guild. These places tend to be much more lax in terms of security and patrols than sky elf towns.

Frontier settlements are small, crude communities founded by independent-minded explorers, settlers, prospectors, or exiles who would much rather avoid civilization. Rough-and-tumble in the extreme, these towns sometimes serve as havens for pirates and other criminals. Sky elf raids on suspected bandit strongholds are common and have led to tensions and minor wars between the elf nations and independent cloud realms.

## Types of Cloud Realms

Most cloud realms are as described above: lush realms that can support crops, settlements, and creatures. However, the magical nature of these realms makes them apt to take on strange and unique forms. The following list categorizes and describes the commonly encountered cloud realms.

**Typical Cloud:** The typical cloud realm is covered with light forest broken up by rolling, grassy plains. In moist areas, a cloud may have a small lake at its center. Towards the cloud edges, mountains of cloud material rise up towards the sky, forming a bowl-like shape. As metal ores are virtually unknown in cloud realms, most settlements founded on these places rely on trade with mining colonies established atop the world's towering mountain peaks. From below, the typical realm looks like a white, fluffy cloud.

**Fire Cloud:** These boiling hot realms are a strange union of fire, earth, and air elemental energies. Sometimes, a dimensional vortex forms a gate between multiple elemental planes. Normally the interplay of opposing energies annihilates the gate, but in some rare cases the mixture of air, earth, and fire energy belches forth what is commonly called a fire cloud. From below, fire clouds look like thunderclouds that flash and rumble with energy. From above, they are heat-blasted, hellish planes of smoking rock. Most travelers would avoid them, save for their one important feature – fire clouds are rich in iron ore and other metals. The humanoid races of the skies battle ferociously for the chance to mine these places. Unfortunately, they are rife with fire creatures, including elementals and stray efrets, and are havens for demons, devils, and other planar threats. Still, metal is rare enough in the sky that the potential profits from extracting ore outweigh the risks.

Fire clouds, also known as hell clouds, are shaped much like normal ones. They are vaguely bowl-shaped from above, though craggy peaks rise from their central areas. The temperature on a fire cloud ranges from 90 to 110 degrees Fahrenheit. Water is unknown on them, forcing travelers to carry their own. Fire-cloud settlements are heavily defended against both aerial and ground assaults. Pirates commonly lurk near these clouds, waiting for an opportunity to seize a departing shipload of ore.

**Floating Island:** A floating island is a large chunk of earth that floats through the sky like a cloud. From below, it looks like a large, dark mass that is far too opaque to be a cloud. Floating islands result from magical experiments gone haywire or an attempt to create a flying citadel, tower, or other structure. Floating islands lack the natural ecosys-



tem of a cloud realm but tend to preserve the plant and animal life that lived on the chunk of rock when it was still earthbound. Most floating islands include a wizard's tower, castle, or other structure that was once some powerful archmage's abode. Others have structures built into them, with wondrous cities crafted from brass, iron, and wood suspended between cloud masses. These sky castles serve as trading centers and resting points along trade routes. Most structures built on clouds are inhabited, but many fall into disuse after the owner dies, moves on to a different lair, or grows bored of life in the sky. Dragons, pirates, and other marauding creatures favor these places as lairs due to their defensibility and the presence of pre-built structures of stone. Obviously rock is a rare commodity in the sky, making a stone castle atop a floating island the ultimate fortress. On the other hand such redoubts are not normally designed to repel aerial attacks, making some of them quite vulnerable to attacks from above.

**Negative-Energy Cloud:** Similar to the process that forms fire clouds, a negative-energy cloud comes into being when a dimensional vortex forms between the air, negative, and prime material planes. These clouds are inky black masses of frigid matter, with temperatures dipping below freezing. From below, they look like slow-moving clouds laden with rain. They utterly block out the sun. These clouds are infested with undead creatures and serve as a thorn in the side of all intelligent aerial races. Their upper surfaces are covered in thick, black ashes. Dead trees, crumbled ruins, and other blasted wreckage litters the area. Flying undead such as spectres and wraiths plague the surface world below these clouds and the aerial region all around them. Necromancers, cultists who worship dark gods, and pirates aligned with such fiends establish small settlements there. Rumors speak of crypts and mausoleums erected by the living dead in honor of their dread masters. If the stories are true, these tunnels contain great treasures and magic looted from the undead's victims.

All undead creatures gain +2 turn resistance while on a negative-energy cloud. This bonus stacks with any resistance the creature normally gains or receives from other sources.

**Sculpted Cloud:** These clouds represent the pinnacle of sky elf magic. Powerful sky elf magicians take mundane clouds and infuse them with raw elemental energy, transforming them into solid material capable of holding outposts, military bases, and other critical strongholds. The fully enclosed elf enclaves that serve as their final line of defense are perched within these clouds, set within the junction of one or more other clouds to give them clear lines of sight to areas both above and below.

Elves typically use sculpted clouds as military bases. Their favorite stratagem is to hollow out a cloud and station a military base within it. Elf rangers and scouts keep watch outside the cloud for pirates and other enemies. When they spot their prey, they launch a diversionary attack to drive the pirates to the apparent safety of the clouds. Unfortunately for the pirates, as they close near to what looks like cover, a small flotilla of elf ships emerges from it to seal their doom.

**Wild Cloud:** Wild clouds are essentially unsettled standard clouds. Forests run rampant over them, as do wild animals, griffons, and other fierce creatures. Some of these clouds hold ancient ruins from older civilizations and lost outposts from an earlier era, making them an attractive destination for adventurers.

## Other Features



Cloud realms aren't the only phenomenon an aerial mariner can encounter in his travels. The following hazards pose a threat to anyone who travels the airways.

**Elemental Pocket:** These seemingly tranquil areas are actually rife with powerful winds and dangerous vortices. A skilled captain can navigate these pockets with ease, but the greatest danger they pose is to inexperienced travelers who fail to note their signs. Most pockets are 5 miles wide. From the outside, an observer must make a Survival check (DC 20) to notice the very vague hints that a pocket lies ahead. An experienced flier can sense the slight shift in the winds and the strange, erratic movement of clouds through this area. Every 10 minutes a sky ship sails through these areas, its captain or helmsman must make a Profession (sky sailor) check (DC 20) or the ship suffers 1d6 points of damage. Sky ships travel through an elemental pocket at half speed.

**Floating Graveyard:** Floating graveyards are the bane of aerial shipping. Within these zones of dead magic, sky ships slowly grind to a halt. Most graveyards are visible from a distance, as they are littered with the wrecked hulks of disabled ships. Worst of all, the graveyard's effect drains a ship's power slowly, leaving it stranded roughly halfway through its area. Graveyards are normally four miles wide. They are haunted by the ghosts of sailors who starved to death within them, and are rife with undead and planar creatures. These areas are attractive to adventurers despite their risks, because many of the ships caught within them are left untouched, their treasures and cargoes waiting to be claimed.

Flying creatures move through graveyards normally. Only sky ships and other magical means of flight, such as spells and magic items, are cancelled by them.

## Adventures

When designing adventures in the sky, remember to emphasize the three-dimensional nature of the realm. Enemies commonly attack from above and below. When the PCs find a new cloud realm, they undoubtedly will fly over it and see what interesting features and terrain they can find. Count on this happening and design adventures that assume the PCs can scout ahead at will.

When designing aerial encounters, use mundane clouds to shelter monsters and allow pirates to strike with surprise. While a fight in the skies lacks a lot of the terrain that can make a ground battle exciting, you can compensate for that shortcoming by using clouds, floating debris, and other interesting features.

Falling is a constant danger in an aerial adventure. The PCs will undoubtedly stock up on spells such as *levitate* and *feather fall*. If a PC does fall from a ship or cloud, allow him to make use of scrolls, potions, or magic items that can save his life. Do not arbitrarily rule that a PC cannot manage to grab such an item from a pouch or pack. After all, it is a long way to the surface. In battle, the bull rush attack becomes a much more attractive option, especially aboard sky ships.





## Chapter One

# Characters



This chapter describes what kinds of heroes exist in the cloud realms. It introduces three new races that are specific to the cloud realms, then discusses heroic legacies that can take the land-born races to the skies. The chapter continues with three new prestige classes, new uses for skills, and a variety of new feats. Finally, it concludes with all sorts of new equipment for your heroes.

## New Races



### Arachial



On a warm, sunny day, a careful observer may sometimes note a dull gray cloud floating high in the sky, one that looks leaden with rain even though the other clouds around it are a fresh, clean white. If the observer is lucky, the cloud floats on and he fails to notice any further details.

If he is unlucky, the arachial colony approaches close enough for him to note the cloud is actually a monstrous nest shaped from the webbing of the marauding spider creatures. He had best hope he has a swift ship or strong redoubt at hand, lest the arachial seize him, entomb him within their dungeons, and slowly drain him of life in an effort to slake their thirst for the blood of the living.



The arachial are intelligent spiders from the elemental plane of air. They wander the air lanes in gigantic colonies of spider webbing that float through the sky, appearing as little more than an oddly colored cloud to the untrained observer. Arachial are masters of magic who excel at striking from ambush. They steer their colonies to lurk above unsuspecting cloud and surface settlements, dispatching their raiding parties to float down upon their victims using parachutes crafted from webbing. As the arachial need the blood and other fluids of living creatures to survive, they favor taking prisoners back to their lairs for later consumption.

**Personality:** Arachial are devious, calculating, and ambitious. They consider a finely planned assassination to be the epitome of art. They view the few-legged ones, as they refer to humanoid, as primitive wretches suitable only for service. Arachial society has a strange dichotomy between its rigid laws against murder, treason, and theft and its inhabitants' tendency to break those laws as often as possible. To the arachial mind, breaking the law isn't enough; one must also do it without arousing any suspicion. Arachial laws serve not to prevent crime but to weed out those spiders who fail to display a proper level of treachery, subtlety, and brilliance in planning their crimes.

**Physical Description:** An arachial is a great spider beast. Its legs are slightly longer in proportion to its body than a giant spider's, allowing it to walk higher off the ground. Their faces are marked with two large yellow eyes that lack pupils or other defining characteristics. When angered, their eyes turn red; while at rest or contented, they shift to an azure blue. Arachial lack mandibles. Instead they feature a wide,







toothy mouth. Beneath their tongue rests a hollow tube they extend to draw blood and other fluids from their victims when feeding. Their front two legs are actually long, black-furred humanoid arms that allow them to wield weapons, forge tools, and work magic. Their hands are round disks set at the end of their arms with eight fingers radiating outward. Elder arachial have short, tough beards that hang from their chins. Males and females are indistinguishable.

Arachial have no need for clothing, as their bodies are covered in tough armored hide and thick, coarse fur. They wear pouches, weapon sheathes, and packs affixed to their underbellies with webbing, allowing them easy access to items. Arachial display a wide range of colors, though blacks and browns are the most common. Elder arachial and those from noble families have primarily bright crimson, sky blue, or yellow bodies, peppered with spots and streaks of different colors. Arachial use dyes and inks to add insignias, color patterns, and other markings to their bodies, particularly on their abdomens.

**Relations:** Arachial see other humanoid races as potential sources of food, though they sometimes ally with races that prove too difficult to conquer, such as giants, evil dragons, and intelligent undead. Arachial hate elves above all other races (primarily because they consider that race's blood a valuable delicacy yet the elves' skill at arms and magic makes them dangerous prey). Arachial have heard many tales of dark elves living deep beneath the earth and the prospect of an alliance with such creatures intrigues them.

Arachial use monstrous spiders as beasts of burden. They keep ettercaps as workers and aides, usually employing them as slave tenders and overseers.

**Alignment:** Arachial are almost always evil, with most of them tending towards lawful evil. Arachial colonies are arranged into strictly ordered hierarchies, with the nobility holding tight control over those beneath them in the pecking order. Arachial society depends on rigidly defined sets of laws, codes of conduct, and rules of etiquette to prevent the self-centered, murderous creatures from turning on each other in struggles for dominance. Within the tight confines of a floating colony, the arachial learned the hard way that order and structure are necessary to rein in their evil impulses.



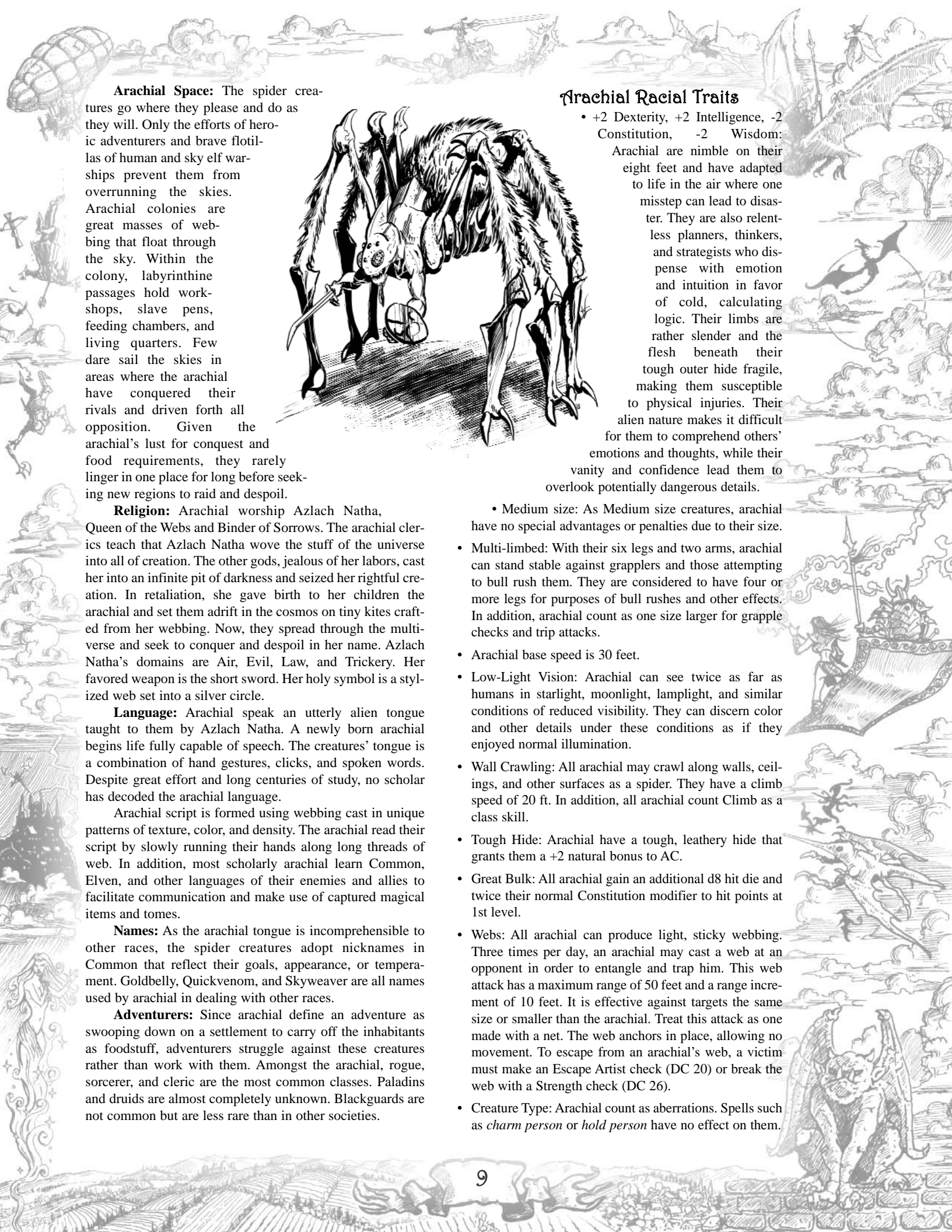

**Arachial Space:** The spider creatures go where they please and do as they will. Only the efforts of heroic adventurers and brave flotillas of human and sky elf warships prevent them from overrunning the skies. Arachial colonies are great masses of webbing that float through the sky. Within the colony, labyrinthine passages hold workshops, slave pens, feeding chambers, and living quarters. Few dare sail the skies in areas where the arachial have conquered their rivals and driven forth all opposition. Given the arachial's lust for conquest and food requirements, they rarely linger in one place for long before seeking new regions to raid and despoil.

**Religion:** Arachial worship Azlach Natha, Queen of the Webs and Binder of Sorrows. The arachial clerics teach that Azlach Natha wove the stuff of the universe into all of creation. The other gods, jealous of her labors, cast her into an infinite pit of darkness and seized her rightful creation. In retaliation, she gave birth to her children the arachial and set them adrift in the cosmos on tiny kites crafted from her webbing. Now, they spread through the multiverse and seek to conquer and despoil in her name. Azlach Natha's domains are Air, Evil, Law, and Trickery. Her favored weapon is the short sword. Her holy symbol is a stylized web set into a silver circle.

**Language:** Arachial speak an utterly alien tongue taught to them by Azlach Natha. A newly born arachial begins life fully capable of speech. The creatures' tongue is a combination of hand gestures, clicks, and spoken words. Despite great effort and long centuries of study, no scholar has decoded the arachial language.

Arachial script is formed using webbing cast in unique patterns of texture, color, and density. The arachial read their script by slowly running their hands along long threads of web. In addition, most scholarly arachial learn Common, Elven, and other languages of their enemies and allies to facilitate communication and make use of captured magical items and tomes.

**Names:** As the arachial tongue is incomprehensible to other races, the spider creatures adopt nicknames in Common that reflect their goals, appearance, or temperament. Goldbelly, Quickvenom, and Skyweaver are all names used by arachial in dealing with other races.

**Adventurers:** Since arachial define an adventure as swooping down on a settlement to carry off the inhabitants as foodstuff, adventurers struggle against these creatures rather than work with them. Amongst the arachial, rogue, sorcerer, and cleric are the most common classes. Paladins and druids are almost completely unknown. Blackguards are not common but are less rare than in other societies.

## Arachial Racial Traits

- +2 Dexterity, +2 Intelligence, -2 Constitution, -2 Wisdom: Arachial are nimble on their eight feet and have adapted to life in the air where one misstep can lead to disaster. They are also relentless planners, thinkers, and strategists who dispense with emotion and intuition in favor of cold, calculating logic. Their limbs are rather slender and the flesh beneath their tough outer hide fragile, making them susceptible to physical injuries. Their alien nature makes it difficult for them to comprehend others' emotions and thoughts, while their vanity and confidence lead them to overlook potentially dangerous details.
- Medium size: As Medium size creatures, arachial have no special advantages or penalties due to their size.
- Multi-limbed: With their six legs and two arms, arachial can stand stable against grapplers and those attempting to bull rush them. They are considered to have four or more legs for purposes of bull rushes and other effects. In addition, arachial count as one size larger for grapple checks and trip attacks.
- Arachial base speed is 30 feet.
- Low-Light Vision: Arachial can see twice as far as humans in starlight, moonlight, lamplight, and similar conditions of reduced visibility. They can discern color and other details under these conditions as if they enjoyed normal illumination.
- Wall Crawling: All arachial may crawl along walls, ceilings, and other surfaces as a spider. They have a climb speed of 20 ft. In addition, all arachial count Climb as a class skill.
- Tough Hide: Arachial have a tough, leathery hide that grants them a +2 natural bonus to AC.
- Great Bulk: All arachial gain an additional d8 hit die and twice their normal Constitution modifier to hit points at 1st level.
- Webs: All arachial can produce light, sticky webbing. Three times per day, an arachial may cast a web at an opponent in order to entangle and trap him. This web attack has a maximum range of 50 feet and a range increment of 10 feet. It is effective against targets the same size or smaller than the arachial. Treat this attack as one made with a net. The web anchors in place, allowing no movement. To escape from an arachial's web, a victim must make an Escape Artist check (DC 20) or break the web with a Strength check (DC 26).
- Creature Type: Arachial count as aberrations. Spells such as *charm person* or *hold person* have no effect on them.



- Automatic Languages: Arachial, Common. Bonus Languages: Any.
- Favored Class: Rogue. Arachial are treacherous creatures with a penchant for ambushes and back stabbing. In their tightly regimented colonies, murder and theft are acknowledged as the two best ways to get ahead in life. Arachial society has powerful laws against such crimes so that only the cleverest and most devious arachial can advance to the top.
- Level Adjustment: +1. Since the average arachial is slightly more powerful than the typical elf, dwarf, human, or halfling, add one to an arachial's character class levels to determine its effective level relative to other characters and monsters.

## Avian

Soaring amongst the clouds in great flocks of warriors and priests, the avians are a fierce race of wandering barbarians who resemble a cross between an orc, human, and bird of prey. They tower over other humanoids, yet their great physiques and strange, craggy, features are overshadowed by the colorful, feathered wings that sprout from their backs and sweep majestically over their shoulders.

Avians are masters of the uppermost reaches of mountain peaks, isolated cloud realms, and the wild air lanes where gnomish dirigibles and sky elf cloudhawks rarely dare to venture. Avians are a proud, independent people who acknowledge no master and spend their days soaring on the winds. Fierce enemies and staunch allies, avians approach all aspects of life (including combat) with a passionate, reckless abandon.

**Personality:** In the uncivilized wilds of the skies, dragons, rogue elementals, and other monsters represent a constant threat. Avians have learned to live life to the fullest. They fight to the death, drink to excess, celebrate a victory for days at a time, and never forget a slight.

Avians wear their emotions on their sleeve. They feel no shame in showing sorrow or expressing joy. As children of the wild upper winds, they value freedom of all sorts above all else. Whether that is freedom to voice an unpopular opinion at a tribal gathering or stay up until morning drinking with the crew of a dwarven airship, avians embrace it and rarely seek to exert control over others.

**Physical Description:** Avians stand well over six feet tall. Their wings sprout from just beside their shoulder blades and are covered in colorful feathers. Avians pride themselves on their plumage and the color patterns they display serve as an important indicator of their lineage and clan membership.

Avians have long, angular faces. Their noses are little more than two oblong nostrils that extend down from their eyes to mouth. They lack hair, instead having light, downy feathers atop their heads. In place of feet they have strong talons covered with tough, thick skin. Avians' skin ranges from pale white to a deep golden brown, while their eyes are commonly blue.

**Relations:** Avians respect the magical abilities of sky elves and work with them as mercenaries, scouts, and guides. They hate arachial above all other creatures and consider the loathsome spider-things to be a horrid blight upon the sky realms. The avians view dwarves, humans, gnomes, orcs and other land-bound creatures with a measure of pity. To the avian view, a life without wings is hardly worth living. They harbor no grudges against these creatures and rarely interact with them. However some avian tribes, particularly those that roost in mountain peaks, form close relationships with dwarves who trade steel weapons and armor with them in

return for the avian's service as scouts and warriors. These avian tribes respect the dwarves' fighting skill and craftsmanship, even if they cannot understand why any sane creature would want to put hundreds of feet of rock between him and the lovely sky.

**Alignment:** Avians are strongly chaotic in nature. They value freedom and believe in allowing creatures to find their own way along the winds. Few avians embrace evil, as their tendency towards freedom pushes them to leave others be rather than seek to harm them. By the same token, chaotic good avians are also rare, though not anywhere near as scarce as evil ones. Avians rarely go out of their way to aid others, but they do not wish travelers and others they meet any particular ill.

**Avian Space:** Avians establish nests composed of clansmen related by blood and marriage in the uppermost mountain reaches or in wild, wandering cloud realms. They co-exist with their environment, hunting and gathering to meet their needs and engaging in limited amounts of craftsmanship. The avians who live amongst the mountains tend to build permanent settlements, while those who wander the clouds move along with the wind. Avians who live in the mountains engage in trade with dwarves and are skilled weaponsmiths and stone masons, while their cloud-dwelling cousins are superior huntsmen and explorers. In both cases, avians use a crude system of democracy to determine policy. Each avian who has completed his coming-of-age ceremony is allowed a vote when the community meets to decide on an issue. The eldest females in the clan form a council of elders who resolve disputes and serve as ambassadors to neighboring clans and settlements.

**Religion:** Avians worship Thyrris, Lady of the Wandering Wind. According to avian lore, Thyrris created the avians as companions to fly with her across the great expanse of the elemental plane of air. Since then, the avians have wandered across the planes, driven by their insatiable desire to fly to the horizon and seek the lands beyond. Thyrris's domains are Air, Chaos, Strength, and War. Her favored weapon is the longspear.

**Language:** Avians speak Auran, the native tongue of the elemental plane of air. Avians were created on that plane and lived there for many generations before migrating across the planar gates to the infinite worlds of the cosmos. Avians also commonly learn the languages of their friends, such as elves and dwarves, and enemies, including giants.

**Names:** Avians use two names: an Auran one derived from their clan name, and an Elven or Common one adopted when dealing with outsiders. Avians pick names that have an appealing sound or describe an aspect of their skill or personality in which they take pride. Examples include Quickwing, Thulviel (Elven for the eastern wind), and

Skyhammer.

**Adventurers:** With their love of freedom and natural curiosity, avians are drawn to adventures by the excitement, danger, and new experiences such a career offers. Parties of surface-dwellers frequently recruit avians as guides and scouts when exploring the upper realms of the air.

## Avian Racial Traits

- **+2 Strength, -2 Intelligence, -2 Charisma:** Avians are powerfully built creatures who develop great physical strength over the many long hours they spend wandering the sky. Their great size also allows them to develop into powerful warriors. On the other hand, avians are rash and impatient, two traits that make it difficult for them to approach problems with a clear, analytical mind. They also can be withdrawn and quiet around strangers, who rarely can understand or relate to the strange-looking avians.
- **Medium size:** As Medium-sized creatures, avians have no special advantages or penalties due to their size.
- **Avian base speed is 30 feet.**
- **Flight:** As winged creatures, avians are capable of flight. They fly at a speed of 80 ft. and have average maneuverability. An avian carrying a medium load reduces his aerial speed to 55 ft. and his maneuverability to poor. One bearing a heavy load reduces his speed to 30 ft. and drops his maneuverability to clumsy.
- **Armor Restrictions:** Avians are limited in the type of armor they wear. Plate mail and similar protection is impossible to use due to the avian's bulky wings. An avian may wear any light armor without penalty and may carry shields as normal. However, they never count as proficient with heavy or medium armor, regardless of class. They may wear such armor but suffer penalties for lacking proficiency, even if they gain the appropriate feats. If an avian wears armor that reduces his base speed, reduce the avian's flying speed by twice the penalty applied to his land speed and reduce his maneuverability by one class.
- **Skills:** The avians' large wings make it difficult for them to take cover against attacks or hide from their enemies. They suffer a -2 racial penalty to Hide checks and reduce the AC bonus they gain from cover by 1.
- **Talons:** While flying, an avian may use its talons in place of an unarmed attack. A talon attack deals 1d4 points of normal damage plus Strength modifier, if any. An avian



monk who uses his talons to make his unarmed attacks gains a +1 racial bonus to damage. An avian may grasp and carry a load, including another living creature, with its talons. On a successful grapple check, an avian may grab and carry aloft an unwilling target. The avian may drop his victim as a move action. While being carried, the avian's victim suffers a -4 penalty to his Dexterity. If he attacks the avian carrying him, the avian counts as having lost his Dexterity bonus to AC even if a class ability or magic item makes this impossible.

- **Automatic Languages:** Common, Auran. Bonus Languages: Draconic, Dwarven, Elven, Giant.
- **Favored Class:** Barbarian. Life in the uppermost reaches of the sky and the forbidding mountain peaks breeds many powerful barbarians amongst the avians. Their tendency to allow their emotions to control their actions makes avians excellent berserkers. Many avians lack the patience and skill necessary to master the training to become a fighter or ranger, preferring to rely on their anger and ferocious temperament to carry the day. An avian barbarian's fast movement ability applies to both his land and air speed.

## Sky Elf

In the ancient days when the elves first walked the world, there existed a tiny splinter of that noble race that was unhappy dwelling within the forests of the young world. These elves preferred feeling the wind flowing through their hair and the warmth of the sun shining on their face. The gods of the elves took pity on their unhappy followers and looked far and wide for a place they could call home. But the world was becoming a crowded place. Humans and halflings had already claimed the plains. Gnomes dug their burrows in

the hills and had little room left for new settlers. The dwarves were secure in their mountain halls, while the sweltering desert and cavern depths were wholly unsuitable to elf settlers. For many years, the gods debated the issue. With no other place in the world for their unhappy minions, they saw no option but to counsel them to accept the circumstances fate dealt them. Furthermore, some of the gods were unhappy that their followers could be so bold as to voice dissatisfaction with the beautiful forest realms they had been given.





Seeing an opportunity to increase his prestige, Laelus, the elf god of storms and winds, offered a solution. Using his mastery of the winds and clouds, he would construct an aerial realm for the dissatisfied elves. After all, the sky was home to both the wind and sun. There was no better place to settle for elves who found their forests too crowded, shadowy, and suffocating. Of course, the elves who accepted his offer would take up his worship. The other elf deities were happy to find a solution to the growing discontent amongst their people, though they were suspicious of the wind god's motives. Still, they allowed his plan to move forward and soon enough the first sky elf city was born. A new era of trade and prosperity awaited the elves. Strong ties between earth and sky might have been forged – had the great war that soon would sunder a rift between dark and surface elves not erupted. Facing threats from the sky and the challenge of building a new civilization, the sky elves played no role in the epic struggle. After centuries of battle, the sky elves became little more than a half-remembered legend amongst the elven courts of the great forests.

Today, the sky elves rule the largest and most stable of the aerial kingdoms. Though they rarely come into contact with surface dwellers, sky elves are one of the most powerful races in the realm above. Between their mastery of magic and their skill at arms, few can stand against them. Luckily for the creatures of the sky, elves are as benevolent as they are mighty. They view the sky as a cherished realm that must be preserved from foul creatures such as arachnids, wyverns, chromatic dragons, and worse. With their flotillas of Warhawks and Daggerdarts, the sky elves enforce the peace in the aerial realm.

**Personality:** Sky elves follow many of the same trends that mark their surface cousins. Their tremendous life spans

allow them to take a long-term view and they rarely rush into a situation without carefully considering their options. They love wine, song, and merriment but are deadly serious in the face of a grave threat or other danger. They are slow to make friends or enemies, but never forget past favors or wrongs.

The biggest difference between sky elves and their grounded cousins is the sky elves' tendency to approach situations in a more practical manner. After enduring centuries of hardship as they carved out their aerial realm, the sky elves have learned to value function over form. While they appreciate art and value beauty, their cities, ships, and items are designed to be practical tools, not things of beauty.

**Physical Description:** Sky elves are slightly taller and stronger than surface elves. They are roughly human in size, running from 5 to 6 feet in height on average and between 125 and 250 pounds in weight. They wear their blonde hair short as a practical matter, as longer hair can get in the way in battle. Sky elves typically sport deeply tanned skin, owing to the many hours they spend in the sun. Their eyes are commonly blue, with many sorcerers amongst them having purple eyes. At first glance, a surface dweller may mistake a sky elf for a half-elf owing to their stronger, taller bodies.

**Relations:** Sky elves consider themselves the proper guardians and caretakers of the aerial realm. They can sometimes be haughty and arrogant towards surface dwellers and avian visitors. They bear no special feelings of alliance to their surface brethren and have little knowledge of their culture and traditions.

**Alignment:** In the face of the hardships they encountered in the course of establishing their aerial kingdom, the sky elves slowly lost the chaotic tendencies of their ancestors. Over time, they grew to form tightly bonded communities that relied on organization, laws, and order to preserve them from dragons, manticores, and other flying threats. Most sky elves are lawful good, with significant minorities lawful neutral, neutral good, and chaotic good. Most sky elf explorers and merchant captains are chaotic, as they find the freedom of traveling across the sky preferable to the sometimes stuffy and rigid sky elf society.

**Sky Elf Space:** Regions controlled by sky elves are marked by strong patrols, safety, and reliable defenses against encroaching creatures. Sky elves aggressively seek out and eliminate potential threats. After working so hard to establish their realms, they are eternally vigilant against the prospect of losing what they worked so hard to build. Sky elf towns, cities, and trading posts are patrolled by wardens who rigidly enforce the law. Noble families control cloud realms and other aerial areas. In return for taxes, these families provide for the defense and maintenance of the realm. Strict rules of heredity dictate lines of succession and the right to rule.

**Religion:** Sky elves worship Laelus, elven god of winds, storms, and the sky. Though Laelus is generally thought of as a chaotic deity by the surface elves, his sky elf cult has taken on a more lawful bent. Sky elves see Laelus as a protective, fatherly figure while their surface cousins see him as a capricious, laughing deity who delights in riding the winds and spreading storm clouds.

As worshiped by sky elves, Laelus is a lawful good deity of protection, clouds, and defense. His domains are Air, Good, Protection, and Sun. His favored weapon is the light flail and his symbol is a silver sun on a blue background.

The surface-elf cult of Laelus sees him as a chaotic neutral deity of storms, winds, and playful trickery. His domains



are Air, Chaos, Trickery, and Water. His favored weapon is the longbow. His symbol is a tree bent over by a great wind.

**Language:** Sky elves speak Elven. Despite the great many years they have been isolated from their surface cousins, the sky elves' language has remained relatively unchanged, thanks to the long elf life span and their reliance on magical and holy texts from their first migration to the clouds.

**Names:** Sky elves select names similar to their surface kin, though their family names draw on aerial imagery and words much more often.

**Adventurers:** Some sky elves exhibit much more traditional elf behavior. These individuals are taken with wanderlust at an early age and are driven to explore the aerial realms. They find the strictly regimented life within sky elf cities dull and cumbersome and leap at the chance to wander where they will and do as they please.

### Sky Elf Racial Traits

- +2 Dexterity, -2 Charisma: Sky elves are as agile as their ancestors, yet they are taller, stronger, and much tougher on average. However, life amongst the clouds has made them much less playful and vibrant than other elves. Sky elves resemble dwarves in that they say little and tend to distrust others.
- Medium size: Sky elves have no special bonuses or penalties due to their size.

- Sky elf base speed is 30 feet.
- All elves are immune to *sleep* spells and effects, including sky elves. They also receive a +2 racial bonus on saves against enchantment spells or effects.
- Low-light Vision: Sky elves can see twice as far as a human in starlight, moonlight, and similar conditions with poor lighting. They can discern colors and other details when using their low-light vision.
- All sky elves learn to help defend their settlements against attack. Sky elves are proficient with the longpear, shortbow, longbow, composite short bow, and composite longbow.
- +2 racial bonus on Balance, Listen, Search, and Spot checks. Sky elves who pass within 5 feet of a secret or concealed door are allowed an automatic Search check to notice the passage. Like their ancestors, sky elves have incredibly keen senses. They are also nimble on their feet, as all elves learn to handle themselves on sky ships with ease.
- Automatic Languages: Common and Elven. Bonus Languages: Auran, Draconic, Dwarven, Giant.
- Favored Class: Wizard. Magic holds an important place in sky elf society. They rely on it to maintain their settlements, build their sky ships, and repel attackers. Arcane studies are encouraged amongst all young elves.

## Surface Races

Travelers from the surface to the sky realms sometimes elect to remain amongst the clouds for quite some time. A few choose to permanently settle there, slowly building settlements comprised primarily of creatures not normally found in the sky. Most surface dwellers live amongst the sky elves. Lacking the ability to fly, humans, gnomes, and others must rely on sky elf ships or powerful magic to travel through the air. Others from the surface are stranded by the loss of whatever means they used to travel to the clouds, a rare mishap while using *teleport* or other travel spells, or some other event. Most surface-worlders quickly adapt to life amongst the clouds and establish themselves amongst the sky elves, avians, and other creatures.

**Humans:** It should come as no surprise that the most numerous of the civilized races also represents the majority of displaced surface worlders. Humans form small enclaves in sky elf cities and serve as ambassadors, traders, and merchant captains. If there is a profit to be made, a human kingdom or guild will invest the gold necessary to establish trade with the realms above. Few humans establish permanent residence amongst the clouds, with most living there for long periods of time as part of some other government or work-related duty. A few pockets of powerful exiled clerics and wizards claim cloud space in order to escape their enemies on the world below. A starting human adventurer may have worked with someone who regularly traveled to the clouds on business matters.

**Dwarves:** While it may seem counterintuitive that a dwarf would leave his mountain halls to explore the sky, many dwarf settlements established at the uppermost reaches of a mountain peak maintain strong ties to avian tribes and

passing sky elf settlements. At that altitude, the lower-lying cloud settlements pass close enough to make trade as easy as stepping off the mountain and on to a cloud. There are no dwarf settlements in the sky, though rumors persist of floating stone citadels held aloft by powerful dwarf magic. Most dwarves who make their home in the sky were stranded there when an unexpected storm or strong wind pushed the cloud they were visiting away from their mountain peak home.

**Elves:** With their natural curiosity and access to powerful magic, many elves wander the sky using spells such as *fly*, *polymorph*, and similar incantations. Given their penchant for wanderlust and love of finding new experiences, elves tend to live amongst the clouds on an extended but temporary basis. Some sky elf cities have a surface elf quarter dedicated to serving the needs of their cousins. However, many elf kingdoms know little of their aerial kin aside from ancient legends, making it likely that a particular sky elf town has never hosted a surface elf in its history.

**Gnomes:** Similar to elves, gnomes are intensely curious about the world around them. They love to experiment, explore, and test their ingenuity by pitting it against seemingly insurmountable obstacles. Some enterprising gnomes choose to tackle the challenge of building a flying contraption, combining their magical and engineering talents to craft dirigibles, gyrocopters, and other flying machines. These gnomes make unexpected – and not always welcome – visits to sky elf cities, often announcing their arrival by crash-landing in the city park or wrapping their out-of-control balloon around a castle spire. Some of these gnomes end up stranded, either waiting for their ship's repair or hopelessly stuck without any method to fix the damage and return home.





These castaways find work on sky ships and hope to earn enough money to buy passage home.

**Half-Elves:** Most half-elves take to the sky as part of a human expedition or trading mission. In addition, many half-elves arise when sky elves engage in trade with human settlements and accept a small enclave of humans in their midst. As outcasts amongst both sides of their heritage, half-elves have the easiest time adapting to a realm where they are in the minority and must live as outsiders. Human kingdoms that wish to open up relations with the sky realms prefer to dispatch half-elf diplomats and traders, confident in their ability to maneuver through unfamiliar social situations and adapt to foreign customs with greater ease than a human.

**Half-Orcs:** Half-orcs find themselves amongst the clouds as part of human expeditions and adventuring parties. Orcs lack the magical and technological resources to build or craft items capable of transporting large numbers of their kind through the air. The violent orc war chieftains have much more pressing matters to attend to, such as sacking a dwarf stronghold. Half-orcs are extremely rare in the clouds, as human diplomatic and trading missions prefer members who are much more adept in social situations. Still, a half-orc is better than almost anyone in a fight. Explorers who anticipate running into griffons, wyverns, and worse recruit half-orc warriors into their ranks, some of whom end up stranded in a cloud city or choose to settle there. Half-orcs face none of the prejudice in the sky that they must handle on the surface. After all, orcs are virtually unknown to sky elves, avians, and others. Thus, of the few half-orcs who do visit the clouds, many elect to settle there.

**Halflings:** Halflings are opportunistic, clever wanderers who would never let a chance at a hefty profit pass them by. Thus, it should come as no surprise that many trade missions include at least one of these diminutive folk. Halflings lack the magical resources to construct flying machines or items, but their contact with other races allows them to bargain and deal for them. A few halfling clans reside permanently amongst the clouds, applying their skill at both stealth and business to act as brokers between surface and sky merchants. After all, neither party knows enough about the other to stand fully confident in their bargaining position. The opportunistic halflings fill this void, working as brokers and traders between the two parties. Few merchants take to the sky without having to deal with a scheming halfling dealer at least once in the course of their career. To the sky elves and other races they work with, halflings are a tremendous boon. While their services are expensive, they drive hard bargains and know enough about the surface world to ensure that the sky dwellers earn a good price for their goods without overpaying for surface weapons, armor, food, and other commodities. In some regions, halfling clans have established powerful trade consortiums that exert tremendous influence on business practices.

# Heroic Legacies

When creating aerial characters, one question must be immediately answered: how did they end up in the sky realms, and how do they survive there now? This is especially important with surface races dwelling in the sky. We answer that question with the concept of a heroic legacy, a new aspect of your character that explains a bit of his background while also granting limited special abilities.

Each starting character in an aerial campaign has one heroic legacy. The heroes who survive in unusual settings like the aerial realms are by their very nature more daring and brave than those who come from traditional lands. After all, they must face additional dangers and limitations on a daily basis. A heroic legacy gives your character the same edge that many of his aerial contemporaries in such a place already have, while simultaneously better equipping him for his adventure and giving him a bit of unique background.

Heroic legacies automatically make your character slightly more powerful than the typical ground-based character of the same level, but not so much as to warrant a level adjustment, particularly when all characters in the campaign have them. They are minor advantages equivalent to the accomplishments of a few encounters or mini-scenarios, almost like minor magic items. It is assumed that simply to survive in the skies your character has already made certain adjustments, and the heroic legacies reflect that.

Any character created for adventures in the sky can choose one heroic legacy from the following options. The GM can also use these for NPCs. In non-aerial campaigns they may be taken as feats but only by first-level characters.

## Air Caster

You learned to cast spells in an aerial environment, either in a cloud city or on a skyship. Constant exposure to elemental energies of the air, as well as specialized training in all aspects of aerial magic, has made you an expert caster of those spells.

**Benefit:** You cast air-related spells at +1 caster level. These include any spells related to air, wind, flight, or the elemental plane of air, including but not limited to *feather fall*, *gust of wind*, *levitate*, *wind wall*, *gaseous form*, *fly*, and *air walk* as well as spells like *gate* when they relate to travel

to the elemental plane of air.

## Air Trader

You come from a family of traders. Your childhood was spent criss-crossing the sky realms in the eternal search for profit. You have a knack for negotiations and trading.

**Benefit:** You start the game with 2 ranks in Diplomacy and Profession (trader). Your maximum ranks are still limited to your class level +3. You treat Diplomacy and Profession (trader) as class skills regardless of your character class.

## Cloud Miner

You come from a family of cloud miners. You grew up in the cramped confines of tunnels carved through the spongy surface of solid clouds, helping your family mine precious metals, gems, and rare elemental deposits. You're skilled at locating valuable veins and picking up on subtle clues that might indicate the presence of a mine or other valuables.

**Benefit:** You start the game with 2 ranks in Spot and Profession (miner). Your maximum ranks are still limited to your class level +3. You treat Spot and Profession (miner) as class skills regardless of your character class.

## Cloud Native

You were born and raised on a cloud city. You've spent every day of your life there and have a lifetime of supplies to draw upon.

**Benefit:** You start the game with an additional 2d4x10 gp in equipment related to life in the air. This can be any sort of aerial weapon or flight armor, or any equipment that would reasonably make sense for life on a sky ship or cloud city.

## Elementally Infused

You are one of the rare people who have adapted to life in the air by developing traits of air elementals. Like the dark elves who gained darkvision and black skin from life in the

## Summary of Heroic Legacies

Legacy	Benefit
Air caster	Cast air-based spells at higher level
Air trader	2 ranks in Diplomacy and Profession (trader)
Cloud miner	2 ranks in Spot and Profession (miner)
Cloud native	Aerial equipment
Elementally infused	Like <i>gaseous form</i>
Oath of Laelus	<i>Feather fall</i> 1/day
Pirate outlaw	Weapon proficiencies
Shipbuilder family	Own sky ship
Skyborne	Use flying mount; Ride as class skill
Stratospheric	Like <i>air walk</i>
Wind sailor	2 ranks in Balance and Profession (sky sailor)
Winged	Fly speed (clumsy)



underworld, you have also adapted. You have an ethereal, airy quality, and a fresh breeze always seem to blow when you're around.

**Benefit:** Once per day with great concentration, you can draw upon trace quantities of elemental energy within your natural composition to turn your body into a gaseous form. This is a spell-like ability similar to *gaseous form* with certain limitations. Only your body transforms; equipment simply falls to the ground in a clattering heap. You can only affect yourself, not other creatures. Your damage reduction is only 3/magic. Transforming is a full-round action, and the gaseous form lasts only as long as you concentrate, up to a maximum of ten minutes.

You gain the "air" descriptor to your type (typically becoming type humanoid (air)). Certain elementally infused beings develop additional abilities. See the elemental convert prestige class on page 19.

### Oath of Laelus



In the early days of elf cloud settlements, the sky elves were besieged. They prayed to their god Laelus for help, and he answered their prayers by working with the elemental queen of air to create the sacred order of air knights (described on page 17). Making that agreement took time, however, and he initially responded by granting special abilities to some of his most trusted clerics. These sacred warriors took an oath to defend Laelus and his followers faithfully. In return, they were granted divine abilities with which to defend their people. These divine abilities changed their very nature.

Many generations have now passed, and these sacred warriors were long ago forgotten in favor of the air knights. But their bloodline lives on. Each generation, a few sky elves are still born with diluted forms of their descendants' powers. You are one of them.

**Benefit:** Once per day, you may magically slow your descent as if you had cast *feather fall* as a 20th-level sorcerer.

### Pirate Outlaw



You grew up prowling the skies for prey. The world is your hunting ground, and you've been fighting against other sky ships since you were a teenager.

**Benefit:** You are automatically proficient with the cutlass, drop net, drop spear, harpoon, and gravity harpoon.

### Shipbuilder Family

You are part of an extended family of great shipbuilders. When you set off to adventure, they bestowed upon you one of their old vessels for your use.

**Benefit:** You start the game with a sky ship of up to 3,000 gp in value. If more than one character in the party has this heroic legacy, they can come from the same extended family or shipbuilder's guild and pool their resources to get a single ship. You cannot sell this ship; it is on loan from your family and must be returned if you ever decide you don't need it anymore. You can't credit the 3,000 gp toward purchase of a larger ship, nor can you keep the change; you start the game with the ship and nothing more. See page 48 for sample sky ship stats.

### Skyborne

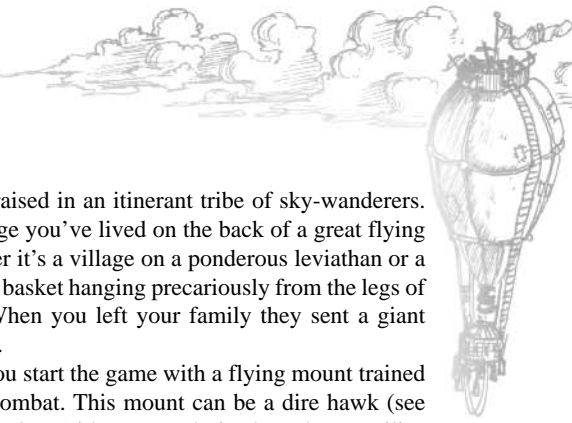

You were raised in an itinerant tribe of sky-wanderers. From an early age you've lived on the back of a great flying creature, whether it's a village on a ponderous leviathan or a narrow sleeping basket hanging precariously from the legs of a giant eagle. When you left your family they sent a giant mount with you.

**Benefit:** You start the game with a flying mount trained to bear you in combat. This mount can be a dire hawk (see page 85) or dire bat (either normal sized or the Noctilius variant shown on page 103). You always treat Ride as a class skill regardless of your character class.

### Stratospheric



You are part of the rare breed of creatures that lives above the clouds, high in the stratosphere. Little is known of these realms, for they are difficult to reach even with the best sky ship. You remember almost nothing about your upbringing, other than being orphaned at a young age and somehow making it to the cloud realms, where you were adopted or raised on the streets. Yet you exhibit strange powers that give some indication of what life must be like in the upper stratosphere. You're taller and leaner than normal creatures of your race, and you have piercing golden eyes that can stare straight at the sun without difficulty. In addition, you have a limited ability to walk on air.

**Benefit:** With great concentration, you can walk on air. You can only perform this supernatural ability in direct sunlight, but other than that it is at will. The effects are exactly like the *air walk* spell but with unlimited duration as long as you concentrate. Performing most combat actions while in the air forces a Concentration check, as detailed in the Concentration skill description. If you fail a Concentration check and begin to fall, you can regain your traction on the air with a DC 20 Reflex save.

### Wind Sailor



Before becoming an adventurer you spent a lifetime sailing the trade lanes, the sun in your eyes and the wind in your hair.

**Benefit:** You start the game with 2 ranks in Balance and Profession (sky sailor). Your maximum ranks are still limited to your class level +3. You treat Balance and Profession (sky sailor) as class skills regardless of your character class.

### Winged



You were born with wings. This may be due to a genetic mutation, cross-breeding, or a legacy of past devotion to Laelus or another god. Your wings are smaller than they should be for a creature your size, but still provide decent flying ability.

**Benefit:** You can fly at a speed equal to your normal land speed with clumsy maneuverability. If you are of a race that normally has wings and you take this heroic legacy, your maneuverability improves by one increment.



A detailed black and white illustration of an aerial campaign. At the top, a large airship with a grid-like pattern is on the left. In the center, a griffon rider on a griffon is shown in flight. To the right, a large sailing vessel with multiple masts and sails is flying through the sky. Below these, various other flying creatures and smaller airships are depicted. The background is filled with clouds and a sense of dynamic movement. The title 'Character Classes' is centered at the top in a large, bold, serif font.

# Character Classes

In the context of an aerial campaign, most of the classes retain the same abilities and roles. A fighter is powerful in combat whether he is a land-dweller with feats such as Great Cleave and Improved Critical or a griffon-rider specialized in the lance. This section discusses each of the base character classes and provides notes for adapting some of them to aerial adventures, regions, or campaign settings.

**Barbarian:** Common amongst the avian race, barbarians are otherwise rare in the aerial realms. Barbarians are produced by a few "lost" sky elf colonies cut off from contact with civilization and left to their own devices for many long years, but generally speaking civilizations must develop advanced magic and technology in order to take root amongst the clouds. Most barbarians who live amongst the clouds were stranded there in the course of an adventure or chose to settle there after acquiring magical means, such as *wings of flying*, to visit the clouds.

**Bards:** Bards fill the same role in the sky as they do on land, acting as traveling storytellers and entertainers. The avians have a strong tradition of passing down songs, stories, and poems from generation. An avian windspeaker, a bard charged with memorizing and passing down his people's history and myths, is a one of the most revered members of the clan.

**Cleric:** Religion plays a strong role in the lives of sky elves, as they credit their deity Laelus with granting them their aerial homes. Domains such as Air and Sun are both common amongst deities whose followers live in the aerial realms.

**Druids:** Amongst the wild clouds that teem with life and the airways free of heavy traffic, the druids reign supreme. Similar to their kin below, the druids tend to the aerial ecosystems and excel in a natural environment. At the GM's option, druids who originate from an aerial realm may remove *meld into stone* from their spell list and replace it with *fly*. Druids in the aerial realm tend to select flying animals, such as hawks and owls, as their animal companions.

**Fighter:** Life in the skies is just as dangerous as on the ground, making skilled fighters a necessity for any civilized outpost. In addition to their normal duties as soldiers,

archers, and commanders, fighters also work as marines aboard sky ships and ride griffons and other flying creatures into battle. Fighters native to an aerial realm may opt to replace Swim with Balance on the class skill list.

**Monk:** The calm, contemplative monks find the serene cloud realms a perfect place to meditate, practice their skills, and attend to their vows. The lawful sky elves founded several monastic orders dedicated to the worship and contemplation of Laelus. The avians and other air races are too free-spirited to accept the regimented life of a monk.

**Paladin:** Amongst the sky elves, paladins stand as shining beacons of hope. In their long struggles to establish their domains, sky elf paladins stood at the forefront of battles against evil dragons, elementals, and other threats. The heroic order of air knights, warriors who ride into battle on griffons and other flying creatures, counts many paladins amongst its numbers.

**Ranger:** Serving as scouts and explorers, rangers are common amongst all sky-dwelling races. Rangers who operate in the sky have a few skills that separate them from their ground-based cousins. At the GM's option, a 2nd level cloud ranger may choose another combat style: aerial fighting. He gains the Agile Flier or Skill Pilot feat, and the Hawkeyed feat, even if he does not meet the normal prerequisites. In addition, the ranger adds *fly* to his 2nd-level spell list and *feather fall* to his 1st-level list.

**Rogue:** Where money changes hands, rogues are sure to be found. Rogues fill the same roles in the sky as they do in ground-based campaigns. Thieves' guilds, usually operating under the cover of a merchant league or trade organization, are commonly found throughout the air lanes.

**Sorcerers and Wizards:** The sky elves depend heavily on their wizards to maintain the defense of their settlements and produce their air ships. Avians and other less-developed races rely more on sorcerers, whose innate talents do not require years of study and training. Arcane spellcasters make up a great proportion of surface dwellers who travel the air lanes, as they have the magical means to journey to and explore the sky.

## Prestige Classes

### Air Knight

When the sky elves first settled in the aerial realm, they faced a daunting multitude of difficulties, the most dangerous of which were the many creatures that prowled the airways. More than one nascent elf settlement fell victim to a marauding dragon, bloodthirsty arachial raiding party, or swarm of elementals. The embattled elves prayed to their deity Laelus for aid against their newfound enemies. The elves had the magic and skill necessary to produce flying vessels, but they were new to the art of aerial combat and were outclassed and outmaneuvered by their enemies at every turn. While the elves fought hard and called up their powerful arcane magic, they lacked the experience and train-

ing necessary to consistently overcome their foes.

Hearing his worshippers' pleas for aid, the elf god devised a simple solution. The elves needed to learn how to fight in skies. The greatest sky fighters in the multiverse were the air elementals, the undisputed kings of the air. Laelus struck a bargain with the elemental queen of air. Laelus agreed to help her topple the rule of the evil dukes of the seven hell winds. In exchange the air queen would bid several royal lines of her children (air elementals, flying creatures, and other natives of the skies) to swear fealty to the sky elf race. However, the queen was wary of dispensing too much power to the elves. She insisted that they must



beneath the air knight banner.

**Hit Die:** d10

## Requirements

To become an air knight, a character must meet the following requirements:

**Balance:** 4 ranks

**Ride:** 8 ranks

**Feats:** Mounted Combat, Aerialist

**Special:** Gain the sponsorship of an air knight by performing an act of bravery in defense of a civilized settlement or completing some task critical to the continued prosperity and survival of a peaceful, good-aligned race.

## Class Skills

The air knight's class skills (and the key ability for each) are Balance (Dex), Climb (Str), Craft (Int), Handle Animal (Cha), Jump (Str), Ride (Dex), Spot (Wis), and Survival (Wis).

**Skill Points at Each Level:** 2 + Int modifier.

## Class Features

All of the following are class features of the air knight prestige class.

**Weapon and Armor Proficiency:** Air knights gain proficiency with light and medium armor, simple and martial weapons, and all shields.

**Aerial Mount:** An air knight forms a bond with a flying creature that serves as his mount. This mount is granted to the knight after he masters the basics of the order's tenets and serves as a squire for a brief, probationary period. When the air knight reaches 2nd level in this class, he has proven himself worthy of a mount and is granted one in an elaborate ceremony. Intelligent flying creatures see themselves as the air knight's partner. They are formed in a team to maximize each other's combat abilities.

At 2nd level, the air knight may choose any flying creature of CR 3 or less to serve as his mount. The creature must be large enough to bear the sky lord and can be from one of the following creature categories: animal, magical beast, or vermin. The creature's alignment automatically matches the air knight's. The order takes care to match knights with compatible creatures from the air queen's stables.

At 5th level, the air knight's fame attracts a more powerful mount, should he choose to accept its offer of alliance or service. The air knight may choose a mount that is CR 6

share the knowledge and fealty she granted to them with other good-aligned races of the sky. Thus were born the air knights, heroic warriors who patrol the airways and defeat demons, dragons, and other creatures that menace the peaceful realms of the elves, avians, and good-aligned air elementals.

The air knights are closely connected to elf settlements. Each city, fortress, and outpost of at least middling size supports a small enclave of these warriors. They train in aerial tactics, working with trained griffons, domesticated wyverns, and other flying mounts. Owing to their divine origin, they learn to command a few magical powers granted as part of the compact formed between Laelus and the queen of the air.

Any warrior who has proven himself a heroic crusader, protector of the weak, and ardent foe of evil is eligible to become a air knight. As part of the divine agreement that formed the basis for this order, the elves may never turn aside a worthy candidate based on his race. In the long history of the air knight orders, gnomes, avians, half-orcs, and other unlikely candidates have soared into battle side by side

Level	Attack	Fort	Ref	Will	Special
1	+1	+2	+0	+0	Improved aerial rider +2, bonus feat
2	+2	+3	+0	+0	Aerial mount
3	+3	+3	+1	+1	Swoop attack
4	+4	+4	+1	+1	Feather fall
5	+5	+4	+1	+1	Improved aerial rider +4, improved mount
6	+6	+5	+2	+2	Bonus feat
7	+7	+5	+2	+2	Aerial awareness
8	+8	+6	+2	+2	Summon air elemental
9	+9	+6	+3	+3	Improved aerial rider +6
10	+10	+7	+3	+3	Bonus feat, improved mount

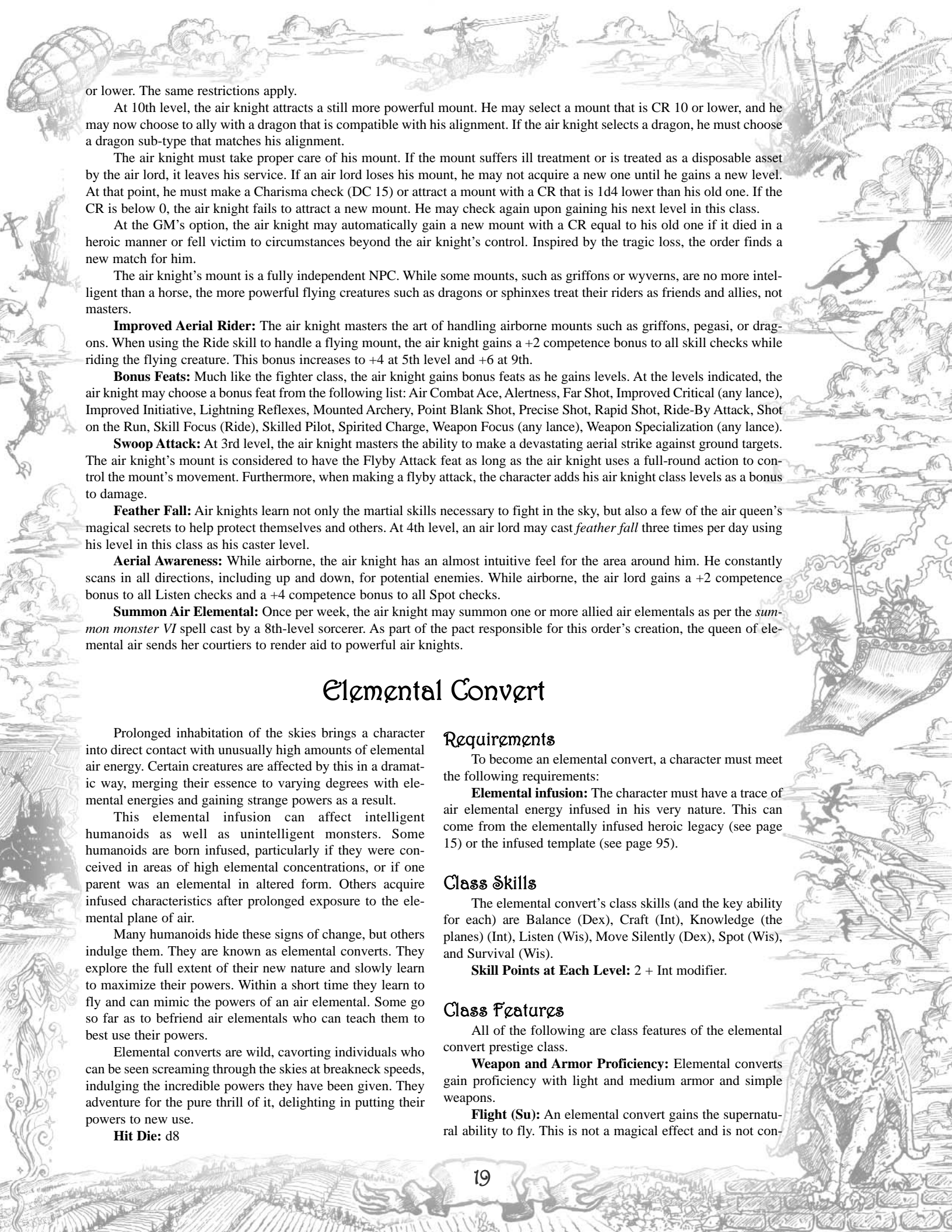

or lower. The same restrictions apply.

At 10th level, the air knight attracts a still more powerful mount. He may select a mount that is CR 10 or lower, and he may now choose to ally with a dragon that is compatible with his alignment. If the air knight selects a dragon, he must choose a dragon sub-type that matches his alignment.

The air knight must take proper care of his mount. If the mount suffers ill treatment or is treated as a disposable asset by the air lord, it leaves his service. If an air lord loses his mount, he may not acquire a new one until he gains a new level. At that point, he must make a Charisma check (DC 15) or attract a mount with a CR that is 1d4 lower than his old one. If the CR is below 0, the air knight fails to attract a new mount. He may check again upon gaining his next level in this class.

At the GM's option, the air knight may automatically gain a new mount with a CR equal to his old one if it died in a heroic manner or fell victim to circumstances beyond the air knight's control. Inspired by the tragic loss, the order finds a new match for him.

The air knight's mount is a fully independent NPC. While some mounts, such as griffons or wyverns, are no more intelligent than a horse, the more powerful flying creatures such as dragons or sphinxes treat their riders as friends and allies, not masters.

**Improved Aerial Rider:** The air knight masters the art of handling airborne mounts such as griffons, pegasi, or dragons. When using the Ride skill to handle a flying mount, the air knight gains a +2 competence bonus to all skill checks while riding the flying creature. This bonus increases to +4 at 5th level and +6 at 9th.

**Bonus Feats:** Much like the fighter class, the air knight gains bonus feats as he gains levels. At the levels indicated, the air knight may choose a bonus feat from the following list: Air Combat Ace, Alertness, Far Shot, Improved Critical (any lance), Improved Initiative, Lightning Reflexes, Mounted Archery, Point Blank Shot, Precise Shot, Rapid Shot, Ride-By Attack, Shot on the Run, Skill Focus (Ride), Skilled Pilot, Spirited Charge, Weapon Focus (any lance), Weapon Specialization (any lance).

**Swoop Attack:** At 3rd level, the air knight masters the ability to make a devastating aerial strike against ground targets. The air knight's mount is considered to have the Flyby Attack feat as long as the air knight uses a full-round action to control the mount's movement. Furthermore, when making a flyby attack, the character adds his air knight class levels as a bonus to damage.

**Feather Fall:** Air knights learn not only the martial skills necessary to fight in the sky, but also a few of the air queen's magical secrets to help protect themselves and others. At 4th level, an air lord may cast *feather fall* three times per day using his level in this class as his caster level.

**Aerial Awareness:** While airborne, the air knight has an almost intuitive feel for the area around him. He constantly scans in all directions, including up and down, for potential enemies. While airborne, the air lord gains a +2 competence bonus to all Listen checks and a +4 competence bonus to all Spot checks.

**Summon Air Elemental:** Once per week, the air knight may summon one or more allied air elementals as per the *summon monster VI* spell cast by a 8th-level sorcerer. As part of the pact responsible for this order's creation, the queen of elemental air sends her courtiers to render aid to powerful air knights.

## Elemental Convert

Prolonged inhabitation of the skies brings a character into direct contact with unusually high amounts of elemental air energy. Certain creatures are affected by this in a dramatic way, merging their essence to varying degrees with elemental energies and gaining strange powers as a result.

This elemental infusion can affect intelligent humanoids as well as unintelligent monsters. Some humanoids are born infused, particularly if they were conceived in areas of high elemental concentrations, or if one parent was an elemental in altered form. Others acquire infused characteristics after prolonged exposure to the elemental plane of air.

Many humanoids hide these signs of change, but others indulge them. They are known as elemental converts. They explore the full extent of their new nature and slowly learn to maximize their powers. Within a short time they learn to fly and can mimic the powers of an air elemental. Some go so far as to befriend air elementals who can teach them to best use their powers.

Elemental converts are wild, cavorting individuals who can be seen screaming through the skies at breakneck speeds, indulging the incredible powers they have been given. They adventure for the pure thrill of it, delighting in putting their powers to new use.

**Hit Die:** d8

### Requirements

To become an elemental convert, a character must meet the following requirements:

**Elemental infusion:** The character must have a trace of air elemental energy infused in his very nature. This can come from the elementally infused heroic legacy (see page 15) or the infused template (see page 95).

### Class Skills

The elemental convert's class skills (and the key ability for each) are Balance (Dex), Craft (Int), Knowledge (the planes) (Int), Listen (Wis), Move Silently (Dex), Spot (Wis), and Survival (Wis).

**Skill Points at Each Level:** 2 + Int modifier.

### Class Features

All of the following are class features of the elemental convert prestige class.

**Weapon and Armor Proficiency:** Elemental converts gain proficiency with light and medium armor and simple weapons.

**Flight (Su):** An elemental convert gains the supernatural ability to fly. This is not a magical effect and is not con-





tingent on the convert's anatomy or free motion; he can fly in an *antimagic field* and can fly even while hog-tied.

The elemental convert's flight speed is equal to twice his land speed. He initially starts with clumsy maneuverability. At 2nd level, his maneuverability improves to poor, then it becomes average at 3rd level. After that it continues to improve with each level he takes in any other class, becoming good after one additional level and perfect after the next level.

If an elemental convert already has the ability to fly through another method, this does not supplant it; he simply gains another method by which to fly.

**Air Mastery (Su):** At 2nd level, the elemental convert gains the air mastery ability, like that of an air elemental. All air-borne attackers take a -1 penalty on attack and damage rolls against him. This includes creatures fighting from the backs of mounts or the decks of sky ships, but does not include creatures fighting from surfaces so large they are effectively land (such as cloud cities or the backs of leviathans).

**Whirlwind (Su):** The elemental convert can transform himself into a whirlwind once per day and remain in that form for up to 1 round for every 2 HD or total class levels it has. In this form, the elemental convert can move through the air or along a surface at its flying speed. The whirlwind is 5 feet wide at the base and 10 feet tall. His equipment is automatically held inside the whirlwind, swirling around at breakneck speed, or he may deposit it at any point along his path.

The character's movement while in whirlwind form does not provoke attacks of opportunity, even if he enters the space another creature occupies. Another creature might be caught in the whirlwind if it touches or enters the whirlwind, or if the convert moves into or through the creature's space.

Creatures one or more size categories smaller than the convert might take damage when caught in the whirlwind and may be lifted into the air. An affected creature must succeed on a Reflex save when it comes into contact with the whirlwind or take 1d6 damage. It must also succeed on a second Reflex save or be picked up bodily and held suspended in the powerful winds, automatically taking 1d6 damage each round. A creature that can fly is allowed a Reflex save each round to escape the whirlwind. The creature still takes damage but can leave if the save is successful. The save DC is equal to 10 + the character's total level divided by two + his Strength modifier.

Creatures trapped in the whirlwind cannot move except to go where the whirlwind carries them or to try to escape. They can otherwise act normally, but must succeed on a Concentration check (DC 15 + spell level) to cast a spell. Creatures caught in the whirlwind take a -4 penalty to Dexterity and a -2 penalty on attack rolls. The elemental convert can have only as many

Elemental Convert					
Level	Attack	Fort	Ref	Will	Special
1	+1	+0	+2	+2	Flight (clumsy)
2	+2	+0	+3	+3	Air mastery, flight (poor)
3	+3	+1	+3	+3	Whirlwind, flight (average)

creatures trapped inside the whirlwind at one time as will fit inside the whirlwind's volume (generally two Medium creatures or one Large creature). The elemental convert can eject any carried creatures whenever it wishes, depositing them wherever the whirlwind happens to be.

If the whirlwind's base touches the ground, it creates a swirling cloud of debris. This cloud is centered on the character and has a diameter of 5 ft. (effectively covering only the whirlwind's square). The cloud obscures all vision, including dark-vision, beyond 5 feet. Creatures 5 feet away have concealment, while those farther away have total concealment.

An elemental convert in whirlwind form cannot make normal attacks, speak, or cast spells, and does not threaten the area around it.

## Sky Elf Battle Captain

Soaring through the sky with majestic ease, the great elf sky ships are the kings of commerce, travel, and war. From the fearsome Battlehawk to the sleek, fast Firefly, elven sky ships have become the standard mode of transportation for the elves and the allied races to whom they sell their creations.

In the early years of sky elf civilization, their battle fleets suffered consistent defeats at the hands of arachial raiding parties, dragons, and other creatures native to the air. In response, the elves formed an elite school dedicated to training a new generation of sky captains who would lead their fleets into battle. The Aerial War College recruited veteran captains who achieved the best results in battle and charged them with dispensing their knowledge to a new generation of captains and admirals. With each passing generation of officers, the best and the brightest returned to pass on their information, leading to a rapid increase in the skill and success of the sky elf fleets. This tradition continues to the present day. To the admirals of the fleet, an appointment to the Aerial War College is an achievement of the highest order.

The sky elf battle captain is a graduate of the prestigious War College. In recent years, the sky elves have taken to allowing mercenary warriors to fight alongside their navy. Thus, the college now takes applicants of any race so long as they have proven their strength of morals and their skill in battle. Battle captains are master tacticians who inspire their crew to great deeds and handle their ships with great skill and ease. A sky elf Battlehawk at the hands of a battle captain moves with sleek, tight precision that belies its bulky, awkward appearance.

**Hit Die:** d8

### Requirements

To become a battle captain, a character must fulfill all the following criteria:

**Diplomacy:** 6 ranks

**Profession (sky sailor):** 8 ranks

**Feats:** Leadership, Sky Captain

**Special:** Gain admittance to the sky elf Aerial War College by defeating a superior force in battle while at the command of a sky ship.

### Class Skills

The battle captain class skills (and the key ability for each) are Balance (Dex), Climb (Str), Craft (Int), Diplomacy (Cha), Profession (Wis), Ride (Dex), Speak Language, Spot (Wis), Survival (Wis), and Use Rope (Dex).

**Skill Points at Each Level:** 4 + Int modifier.

### Class Features

All of the following are class features of the battle captain prestige class.

**Weapon and Armor Proficiency:** A battle captain gains proficiency with simple weapons, rapier, light cross-bow, light armor, and shields. He gains no additional proficiencies with weapons, armor, or shields.

**Freebooter:** Many of the graduates of the Aerial War College are granted ships and charged with traveling the skies in search of new cloud realms to explore and evil menaces to defeat. Unless the battle captain opts to join the navy as a line officer, he is granted a ship of his own, a full crew, and a charter to engage and defeat pirates, monsters, and other threats with the blessings of the sky elf kingdom. The battle captain gains a sky ship worth up to 30,000 gp times his level in this class. At 1st level, he may request an average crew and at 5th level an elite one. These crew members are loyal to the battle captain and obey his orders to the best of their ability. This loyalty does not extend to the battle captain's companions, though they will work with them and obey orders that fit into the captain's mission. However, the battle captain's adventuring partners cannot seize control of the ship and start commanding the crew.

The sky elf government pays the crew's wages. If the battle captain loses his ship, he must wait 2d6 months to receive a replacement. He automatically gains new crew each time he docks at a sky elf settlement staffed by ships from the sky elf navy.

The battle captain is responsible for the well-being of his ship and crew. If he mistreats them, abuses them, or needlessly risks them for personal gain, the sky elf navy may court-martial him. At the GM's option, a foolish battle captain may be imprisoned or executed for treason.

**Skilled Captain:** Under the battle captain's watchful

### Sky Elf Battle Captain

Level	Attack	Fort	Ref	Will	Special
1	+0	+0	+2	+2	Freebooter, skilled captain
2	+1	+0	+3	+3	Inspiring leader
3	+2	+1	+3	+3	Artful dodger
4	+3	+1	+4	+4	Sky master
5	+3	+1	+4	+4	Master strategist



eye and steady leadership, his crew works with increased efficiency. Increase the maneuverability rating of a ship he captains by one class. This effect remains so long as the battle captain is aboard the ship and alive.

**Inspiring Leader:** Any member of the battle captain's crew who can draw a clear line of sight to him gains a +4 morale bonus on all saves against fear and fear-based effects. In addition, the bonus provided by the Sky Captain feat increases to +2. This stacks with a bard's ability to inspire courage.

**Artful Dodger:** The battle captain's combat experience allows him to judge his enemies' attacks and set his crew to making evasive maneuvers. Any ship under the battle cap-

tain's command gains a +2 dodge bonus to AC so long as it is capable of movement.

**Sky Master:** The battle captain is an expert at judging the wind and positioning his ship. He gains a +4 bonus to initiative when in command of a ship and increases his ship's base speed by 25%.

**Master Strategist:** At 5th level the battle captain is a supreme tactician and commander. In battle, he may use a standard action to study a single opponent and hold his move action. When that opponent takes his action, the sky captain may then use his move action to maneuver his ship after the opponent declares and targets all of his attacks but before determining damage. Thus, a battle captain could move his ship behind cover after his enemy has decided to fire upon him but before making his attack roll. If, as a result of this move, the battle captain's ship gains the benefits of cover or concealment, apply those modifiers to the attacks. If the ship was the target of an area-effect attack but moved out of it, the ship avoids the attack and takes no damage. When using this ability, the sky captain's initiative count does not change.

## New Uses for Skills

The Profession skill has several new uses in the sky lanes.

### Profession

There are several Profession skills that are extremely useful to life in the sky, particularly miner, trader, and sky sailor.

**Profession (miner):** This skill enables someone to mine ores, gems, and other valuables for a living. It includes knowing where to look, the best ways to mine, how to extract valuables most efficiently, and where to sell the raw ore. It also includes basic proficiency in the tools of the miner, most of which don't have combat application, but it does grant combat weapon proficiency with the pick.

**Profession (sky sailor):** A sky sailor knows how to sail sky ships. In many respects this is quite similar to sailing naval ships. The use of sails and rigging is very similar, and the choppy nature of air turbulence has a lot in common with the choppy water stirred up by a storm. Some things are different, however. Sky sailing requires a three-dimensional understanding of the winds, and the weather patterns under the clouds are quite different from those above. Someone with Profession (sky sailor) can use his knowledge to sail a naval ship, but suffers a -2 penalty to all skill checks. And vice versa - someone with Profession (sailor) can use his knowledge to sail a sky ship, but at a -2 penalty to all checks.

**Profession (trader):** This skill encompasses all aspects of trading for a living. It includes knowing market trends, how much goods are worth, and when to buy and when to sell. It also encompasses the basic negotiation skills necessary to get a good price, though these aren't necessarily the same skills used to impress people or win new customers. Some traders get good prices because they're hard-nosed jerks, after all. Nonetheless, a character with 5 or more ranks in Diplomacy receives a +2 synergy bonus to checks in Profession (trader). Full details on merchant trading in the sky lanes can be found on page 128.





# Feats

The new feats presented here are designed for use in aerial campaigns. Feats with the fighter keyword listed next to their name may be chosen with the fighter class's bonus feats. Some feats are specific to a certain race or monster, especially avians and arachial. These are due to special training or unusual anatomy, and are presented here with the rest of the feats.

As a rule of thumb, only characters who grew up in an aerial realm or have extensive experience living in the air may take these feats.

## Aerial Positioning [Fighter, General]

You can position yourself to take advantage of chinks in an opponent's armor, weak points in his defense, and angles his shield can't reach.

**Prerequisite:** Ability to fly, perfect maneuverability, base attack bonus +4.

**Benefit:** When you are flying, you ignore all armor class bonuses due to an opponent's shield and any enhancement bonuses it may have (except for shields with the *fortification* special quality, which ignore the effects of this feat). In addition, when you make feint attacks against other airborne creatures (those whom you can maneuver around in a full 360 degrees), you not only rob them of Dexterity bonuses to AC, but also reduce their armor or natural armor bonus to AC by -2, to a minimum of 0.

## Aerialist [General]

You have trained with a wide variety of flying creatures. Your experience traveling by air has given you an innate sense for thermals, shifts in the wind, updrafts, and other changes in the ebb and flow of the air. These two factors in combination make you perfectly suited for aerial travel.

**Benefit:** You receive a +2 bonus to all Profession (sky sailor) checks and Ride checks when on a flying mount.

## Agile Flier [Fighter, General]

You are a skilled aerialist capable of performing tight turns and other aerial feats that others of your race cannot normally complete.

**Prerequisite:** Ability to fly via natural or magical means.

**Benefit:** Increase your flying maneuverability by one rank. For example, a creature rated as a good flier becomes a perfect one with this feat. A perfect flier with this feat ignores the first increment of reduction in maneuverability due to adverse effects.

**Normal:** A creature's flying maneuverability cannot be modified.

**Special:** A creature with this feat that uses a magic item to fly, such as *wings of flying*, improves the maneuverability granted by the item by one rank.

The bonus granted by this feat does not extend to flying mounts or magic items that must be ridden, such as a *carpet of flying*. The Skilled Pilot feat applies to such instances.

You may only gain this feat once. You may not take it multiple times to increase your maneuverability by more than one rank.

## Air Combat Ace [Fighter, General]

You are a master of the skies. The air is your home element, and you fight best on the back of a flying beast or when winging through the air. You baffle attackers with the ease with which you evade their attacks.

**Prerequisite:** Mounted Combat, 13+ ranks in Ride

**Benefit:** Under your guidance, your mount nimbly dodges area-effect attacks. If you spend a full round action preparing to maneuver, you may immediately move on an enemy's initiative count after determining the extent of an area of effect. You may take no other action that round, though your mount is allowed a standard action before or after the move. Your initiative count does not change.

## Blood Drinker [Arachial]

Arachials believe that drinking the blood of elves gives them great power. For some, this is true.

**Prerequisites:** Arachial

**Benefits:** You benefit from ingesting elven blood. If you drink a pint of fresh elf blood, you gain a +1 morale bonus to all attack and damage rolls, skill and ability checks, and saves for one hour. The blood must have come from an elf that was living within the past four hours. You can only gain this bonus a maximum of once per day, and it does not exceed +1 no matter how much blood you drink. Furthermore, the blood of an individual elf can only give you this bonus once. After you have tasted a specific elf's blood, it will no longer benefit you; you need the blood of another elf to use this feat again.

## Cascading Bull Rush [Fighter, General]

You can plow into enemies, pushing them even further back than usual. This feat is especially useful for repelling boarders on a sky ship.

**Prerequisites:** Str 15, Power Attack, Improved Bull Rush

**Benefit:** When you perform a bull rush, you gain an additional +4 bonus to the check. This stacks with Improved Bull Rush. You also learn two new bull rush techniques.

First, you can push back bull-rushed opponents up to 10 feet initially, plus up to another 10 feet for every 5 points by which you beat their score. The distance you can push them is effectively doubled.

Secondly, you can push opponents back through other opponents (or allies). If a creature blocks the area into which you're trying to push back a successfully bull-rushed opponent, you can try to shove it out of the way, too. Make a bull rush check against that second creature. If you fail, your progress in the initial bull rush is blocked. If you win (by any margin), you can push back both enemies at the "cost" (based on the available movement distance from the *first* bull rush) of 5 feet per creature per 5 feet moved. That is, shoving two creatures back 5 feet costs 10 feet of movement from the total distance of the first bull rush. In this manner, you can cascade the impact of a bull rush through an entire row of invaders. If you push invaders off the edge of a sky ship, they simply fall off.

For example, a sky sailor with this feat is trying to repel

## New Feats

### General Feats

Aerial Positioning<sup>1</sup>

Aerialist

Skilled Pilot

Agile Flyer<sup>1</sup>

Air Combat Ace<sup>1</sup>

Cascading Bull Rush<sup>1</sup>

Explosive Attack<sup>1</sup>

Tornado Barrage<sup>1</sup>

Flyby Attack<sup>1</sup>

Flyby Cleave<sup>1</sup>

Hawkeyed

Merchant Guildsman

Shot from Above<sup>1</sup>

Spinaround Blow<sup>1</sup>

Sky Captain

Sky Lord's Luck

Sky Lord's Blessing

Steady Feet

Thunderbolt Charge<sup>1</sup>

### Arachial Feats

Blood Drinker

Spiderwings

Sticky Web

Web Hide

Web Line

### Avian Feats

Dive Bomb

Talon Attack

Wing Parry

Wingwielder

### Item Creation Feats

Sky Shipwright

### Metamagic Feats

Innate Spell

### Prerequisites

Ability to fly, perfect maneuverability, BAB +4

–

Aerialist

Ability to fly

Mounted Combat, Ride 13+ ranks

Str 15, Power Attack, Improved Bull Rush

Dex 17, Point Blank Shot, Rapid Shot, BAB +4

Ability to hover, Dex 17, Point Blank Shot, Rapid Shot, Explosive Attack, BAB+6

Fly speed, BAB +4

Flyby Attack, Power Attack, Cleave

Alertness

Diplomacy 3+

Point Blank Shot, Dex 13+

Ability to fly, BAB +1, average maneuverability

Leadership

–

Sky Lord's Luck

–

Natural ability to fly

### Prerequisites

Arachial

Arachial

Arachial

Arachial

Arachial

### Prerequisites

Avian, Flyby Attack, Ref +6, Thunderbolt Charge

Avian

Avian, Combat Reflexes

Avian, Dex 13

### Prerequisites

Arcane caster level 9+

### Prerequisites

–

### Benefit

Ignore shield bonuses, better feint while in air

+2 to Profession (sky sailor) and Ride Increase flying mount's maneuverability

Increase maneuverability by one rank

May dodge area effect attacks while airborne

+4 bull rush, push enemies into one another; improved bull rushing distance

Throw many unaimed weapons in cone-shaped attack area

Explosive attack in 360-degree sphere

Take standard action during flying move

Cleave along path of flight

No penalty to ranged Spot checks; reduced penalty to ranged attacks

Reduce price of goods by 5%

Inflict extra damage with ranged attacks from above

Spin in place to add extra damage from momentum

+1 morale bonus for crew

+5 insight bonus to any save, 1/week

Cast *feather fall* 1/day

+2 to Balance checks and to resisting grapples, trips, and bull rushes

Double damage on charge from above

### Benefit

Temporary +1 to attack, damage, checks, saves

Spin silk wings that allow gliding

Prey has -4 to escape from webs

Spin web hide to gain +1 natural armor

Spin rope-like web line

### Benefit

Attack after free fall; +20d6 damage; Ref save or crash

Gain talon attack

Parry enemy blows with your wings

Wield special shield with your wings

### Benefit

Create sky ships

### Benefit

Sacrifice spell slot to gain permanent spell-like ability

<sup>1</sup> A fighter may select this as one of his bonus feats.



a pirate boarder, who has two more pirate allies boarding directly behind him. In the opposed checks, the sky sailor gets a 34 versus the pirate's result of 22. The sky sailor wins by a difference of 12. He pushes the pirate back 10 feet on the initial shove, plus up to 20 feet more due to the 12-point difference, for a total of 30 feet. (Without this feat, the distance pushed back would be only 15 feet.) Because the pirate's two allies are behind him, the sky sailor must make bull rush checks against them in order to push them all back. He does so and wins both checks. Thus, he can now "pay" 15 feet of movement to shift all 3 enemies back 5 feet. The sky sailor does so, knocking the last pirate off the ship. There are now only two opponents left, and the sky sailor has 15 feet of movement left. He pays 10 feet of that to push the pirates back 5 more feet, this time pushing another pirate over the edge. There is one opponent left, and the sky sailor has 5 feet of movement left. He uses this last amount to shove the remaining pirate over the edge.

### Dive Bomb [Avian]

You can make daring, near-suicidal dive-bomb attacks. More civilized races consider these attacks insane, but to you, they're a thrill.

**Prerequisite:** Avian, Flyby Attack, Reflex save +6, Thunderbolt Charge

**Benefit:** You can slip into a free fall before making an attack, and usually recover in time to avoid crashing. You must start at least 200 feet above your target and enter a free fall. You must free-fall until you hit your target. Remember that you fall 150 feet on the first round of free-fall and 300 feet on the next round. You cannot move faster than this; it has to be an uncontrolled fall. You may only steer to a limited degree; when in a free-fall you can use your wings to adjust where you'll land by up to half your normal flying speed each round, but you may make no other movement or you'll break the free fall. In other words, your horizontal position may change by up to half your speed but no more. If your target is aware of your dive bomb attack, it can usually fly out of range of your trajectory before you make impact. While in a free-fall you may make no actions other than to fall and adjust your position as above.

Once you have fallen at least 200 feet, you may make a single attack against one creature you pass on your descent. This attack is at your highest base attack bonus. If it hits, you inflict an additional +20d6 falling damage to your target. You do not take any falling damage (yet).

The attack breaks the free fall and sends you into a tail-spin. You must now make a Reflex save to pull out of the dive. Attempting to pull out is a full round action. The save is at DC 20 + 2 per round spent falling (minimum DC 24, since the attack is made no earlier than the second round of falling). If you make the save, you pull out of the dive and can fly normally. If you fail the save, you continue to plummet to earth at a rate of 300 feet per round. If you hit the ground, you take normal falling damage.

Pairs of avians flying at different altitudes often use this attack. While one grapples the opponent and holds him aloft, the other dive bombs from far above.

**Normal:** An avian with the Flyby Attack feat can still attack creatures it passes while flying, but without this feat it can only inflict falling damage by impacting with a target and also taking falling damage itself.

### Explosive Attack [Fighter, General]

You shower an area with projectile weapons, throwing wildly and hoping to hit as many targets as possible.

**Prerequisites:** Dex 17, Point Blank Shot, Rapid Shot, base attack bonus +4

**Benefit:** You can hurl weapons in an attack that covers a 60-foot cone. You must be using a thrown weapon, and the number of targets affected is limited by how many weapons you can hold and throw at a time. When throwing wildly like this, you can hold two weapons per hand of those your size (for example, a human holding a Medium throwing axe) or four weapons per hand of those a size smaller (for example, a human holding a Small dart). If you have the Quick Draw feat, you can immediately draw two more weapons and have them contribute to the weapons in flight.

All targets in the cone-shaped area of effect are eligible to be hit, including friends and allies – you can't discriminate in an explosive attack. Resolve the attack target by target, starting with those closest to you. Make a ranged attack at your highest base attack bonus against each target, but apply a –4 penalty to the attack roll and do not use your Dexterity bonus (since an explosive attack is not carefully aimed). Apply range penalties as normal. You get one chance to hit each target, and cannot hit more targets than the number of projectiles thrown. If there are more targets than thrown weapons, it is possible to run out of available targets after enough shots hit.

For example, let's say a human fighter with Quick Draw throws eight Small darts (four in each hand), then immediately draws and throws two more. A total of ten darts are in the air. There are 16 pirates boarding in the 60-foot cone he targets. He hits with the first 4, misses the next 3, then hits with 6 in a row. After the tenth dart hits (on roll #13), he stops rolling. He made attacks against 13 of the pirates, and hit 10 of them. The last 3 pirates were saved by the fact that his other darts landed before reaching them.

Making an explosive attack is a full-round action. If you make an explosive attack, you do not gain any additional attacks this round. You cannot combine an explosive attack with another standard action or a charge. Explosive attacks can only be made with thrown weapons and count as ranged attacks for the purposes of attacks of opportunity.

### Flyby Attack [Fighter, General]

You are skilled in swooping through the air to attack your enemies.

**Prerequisite:** Fly speed, base attack bonus 4+.

**Benefit:** When flying, you can take a move action (including a dive) and another standard action at any point during the move. You cannot take a second move action during a round when you make a flyby attack.

**Normal:** Without this feat, you take a standard action either before or after your move.

**Special:** This feat is slightly modified from its original version. A base attack bonus prerequisite was added to make it suitable for flying PCs. You may not use this feat if you fly by riding a mount.

### Flyby Cleave [Fighter, General]

You can cleave along the path of a flyby attack.

**Prerequisites:** Flyby Attack, Power Attack, Cleave

**Benefit:** If you drop an opponent while making a flyby





attack (typically by reducing it to 0 hit points or below), you may make an extra melee attack against another creature. However, this creature need not be within 5 feet. It can be anywhere along the continued path of your remaining flying movement, with maneuverability restrictions taken into account. If you have Great Cleave, you may continue making flyby cleaves as long as you drop each successive target.

**Normal:** Normally you can cleave only against targets within reach of the position from which you dropped the first enemy, and may not even take a 5 foot step.

**Special:** You only get the additional cleaves if you are flying; this feat grants no benefit to creatures on the ground.

### Hawkeyed [General]

You have exceptionally keen eyesight, allowing you to spot tiny details at a great distance.

**Prerequisite:** Alertness.

**Benefit:** When using the Spot skill, reduce any penalties for looking at an object in the distance by 5. When using missile weapons, reduce the penalty to attack rolls based on your target's range by 2.

**Normal:** You suffer a -1 penalty to Spot checks for every 10-foot increment in distance between you and a hidden object. Ranged attacks suffer a -2 penalty per range increment.

**Special:** This feat does not provide a bonus. It only reduces a penalty. For example, when studying an object 30 feet away you do not suffer a penalty for that distance. Reducing the -3 penalty by 5 changes it into a 0 penalty, not a +2 bonus.

### Innate Spell [Metamagic]

With dark rituals and mysterious abilities, you imbue yourself with the ability to cast certain spells as if they were natural abilities.

**Benefit:** You can permanently sacrifice a spell slot to gain one spell of that level as a spell-like special ability. A spell-like special ability cannot be counterspelled and cannot be used to counterspell. It has no verbal, somatic, material, or focus requirements, and requires no memorization or preparation. In all other respects, it is like the spell as you would normally cast it, with caster level based on your normal caster level. You can cast the spell once per day.

Spells that require XP for casting cannot be made into innate spells. Once a spell is chosen as an innate spell, it can never be changed, and the spell slot can never be regained, not even through a *wish*.

Wizards native to the skies often use this feat to make *fly* or *feather fall* innate.

### Merchant Guildsman [General]

You are a member of a prestigious trading company or merchants' guild. You have a finger on the market's pulse. With your business connections, you can buy and sell items at excellent prices.

**Prerequisite:** 3+ ranks in Diplomacy

**Benefit:** Reduce price of items you purchase by 5%.

### Shot from Above [Fighter, General]

Your ranged attacks deal extra damage if your target is below you.

**Prerequisite:** Dex 13+, Point Blank Shot

**Benefit:** You can inflict extra damage by firing on enemies below you. For every range increment (based on the weapon used) of vertical distance between you and your target, you inflict an extra 1d6 damage, to a maximum bonus of +3d6. Note that the extra damage is contingent on the vertical distance between you and your target. For example, a longbow has a 100 ft. range increment. A target that is 201 feet (two range increments) away horizontally, but only 20 feet below your altitude, would not suffer any extra damage. If the same target were 201 feet away and 201 feet below you, it would take an extra 2d6 damage.

### Skilled Pilot [Fighter, General]

You are a skilled pilot capable of handling flying beasts such as griffons or pegasi with ease. Under your control, such creatures perform much better than normal.

**Prerequisite:** Aerialist

**Benefit:** Increase your flying mount's maneuverability by one rank. For example, a griffon normally has a maneuverability of average. While under your control, it gains good maneuverability.

**Normal:** A creature's flying maneuverability cannot be modified.

**Special:** You may only gain this feat once. You may not take it multiple times to increase maneuverability by more than one rank. You can use this feat to increase the maneuverability of a magic item or skyship, but only those whose size is no more than one increment larger than your own.

### Sky Captain [General]

You have commanded ships in the past and know how to get the most out of a crew without pushing them too hard. Under your watchful eye, a sky ship operates smoothly and efficiently.

**Prerequisite:** Leadership

**Benefit:** While you act as a commander of a ship, NPC crew members gain a +1 morale bonus to initiative, skill checks, and attack rolls. You must be identified as the ship's captain and accepted by the crew. You could not simply start barking orders in the middle of battle while traveling aboard a ship. The crew must recognize your authority and obey your commands.

**Special:** This feat also applies to seagoing crews under your command.

### Sky Lord's Blessing [General]

The lords of cloud and air have a particular affection for you, and take active steps to help preserve your life. While their methods are limited, they can spell the difference between life or death on the sky ways.

**Prerequisite:** Sky Lord's Luck

**Benefit:** Once per day you may cast *feather fall* as a divine spell with a caster level equal to your hit dice.

**Special:** You may take this feat only once. You may not take it multiple times to gain more than one *feather fall* per day.

### Sky Lord's Luck [General]

Your good luck is renowned amongst the crew of the sky ships that sail the air lanes. Whenever danger comes calling,

you always seem to get your head under cover just in the nick of time.

**Benefit:** Once per week, you gain a +5 insight bonus to any saving throw.

**Special:** You must elect to use this feat before making your roll or learning the save's DC. You may take this feat only once.

### Sky Shipwright [Item Creation]

Your studies of magic allow you to design and direct the construction of a sky ship, a great flying vessel.

**Prerequisite:** Arcane caster level 9+

**Benefit:** You may create sky ships. Consult the rules on page 44 for full details on this process.

### Spiderwings [Arachial]

You have developed a technique for weaving webbing between your legs, creating a parachute of sorts that gives you limited ability to glide.

**Prerequisites:** Arachial

**Benefits:** You can spend one hour each morning spinning spiderwings between your legs that allow you to glide. As a full-round action, you can glide up to 50 feet per round with average maneuverability, descending 5 feet for every 10 feet of horizontal distance. You can take no other actions while gliding. You cannot glide more than 50 feet in a round, and you cannot glide less than 50 feet in a round unless you touch down. If you fall, you automatically break into a glide.

### Spinaround Blow [Fighter, General]

You can pivot in place to deliver forceful blows.

**Prerequisite:** Ability to fly, average or better maneuverability, base attack bonus +1

**Benefit:** You spin in place and use the momentum it generates to do additional damage to your enemies. For each full 360-degree spin you make before attempting an attack, you deal an additional 1 point of damage.

A spinaround blow is always a standard action, because you must use a move action to begin spinning prior to your attack action. Spinaround blows cannot be used as part of a full attack action. A creature with average maneuverability pays 40 ft. of movement for every full 360-degree spin. A creature with good maneuverability pays 20 ft. of movement for every full 360-degree spin. A creature with perfect maneuverability pays no movement cost for the spin, but can make no more than 5 spins in one round. Creatures with poor or clumsy maneuverability cannot turn in place, and thus cannot attempt spinaround blows.

Spinaround blows are only possible when flying. When on the ground, the footwork required slows down the spins to the point where the attacker simply can't generate enough momentum. A spinaround blow can only be used by a creature capable of flying by their own native ability; riders do not benefit from it.

### Steady Feet [General]

You are exceptionally difficult to knock over or topple. You are good at keeping your feet beneath you and maintaining your balance.

**Benefit:** You gain a +2 bonus to Balance checks. In addition, you gain a +2 bonus to grapple checks when others



try to grapple or grab you. You gain a +2 stability bonus to resist trip attacks and bull rushes.

**Special:** The grapple check bonus provided by this feat applies only to checks made when others attempt to grapple you. You do not gain it when you initiate the grapple attack.

### Sticky Web [Arachial]

Some arachial have a special gland that makes them capable of producing exceptionally sticky webbing. This makes it all the more difficult for their prey to disentangle itself from their webs.

**Prerequisites:** Arachial

**Benefits:** The webs you create are extremely sticky. Trapped prey attempting to escape with an Escape Artist or Strength check receive a -4 penalty to their roll.

### Talon Attack [Avian]

You have learned to use your talons in addition to your normal melee attacks. Avians are fierce fighters and many learn to slash foes with their claws in addition to using their swords and axes.

**Prerequisite:** Avian

**Benefit:** When using the full attack action, you may make an additional attack with your talons with a -5 penalty using your highest base attack bonus. You may only use this feat while flying.

### Thunderbolt Charge [Fighter, General]

You have learned to maximize the benefit of gaining an altitude advantage against an enemy.

**Prerequisite:** Natural ability to fly.

**Benefit:** When using the charge action, if you begin your charge more than 20 ft. above your enemy and make your entire charge move by flying you deal double damage



on a successful attack. This damage multiplier stacks with any provided by critical hits or other feats.

**Special:** You gain this bonus damage only if you are capable of flying via wings or a magic item. If you must ride a creature, item, or other craft, you do not gain the damage multiplier.

### Tornado Barrage [Fighter, General]

You can whirl about in the air, showering projectiles everywhere around you.

**Prerequisite:** Ability to hover, Dex 17, Point Blank Shot, Rapid Shot, Explosive Attack, base attack bonus +6

**Benefits:** You can make an explosive attack (as the feat) that covers a full 360-degree spherical arc around you. You must be hovering in place when making the tornado barrage attack, which counts as a full-round action.

You hurl your weapons in all directions, potentially hitting creatures all around you. Your area of effect is a sphere, centered on yourself, that encompasses all space in a 60-foot three-dimensional radius. Resolve the tornado barrage as an explosive attack. All creatures within the sphere are liable to be hit, and attack results are determined starting with the closest target and then radiating outward.

### Web Hide [Arachial]

Certain arachial develop web glands across their hide. With these glands they weave a special hide of webbing around their skin, which makes them more durable without affecting their agility.

**Prerequisites:** Arachial

**Benefits:** You can spend one hour each morning spinning a web hide. You then receive a +1 natural armor bonus for the rest of the day. You must spin a new web each morning.

### Web Line [Arachial]

Some arachial have learned to spin a web rope instead of a net.

**Prerequisites:** Arachial

**Benefits:** You may use one of your daily web-casting slots to instead create a 100-foot-long web line capable of carrying up to five times your body weight. With a ranged touch attack (50 ft. range increment), you may use this ability to shoot a weblines at a target. If it hits, you can use your movement action to make an opposed Strength check to reel in the target at a rate of 10 feet per round. You receive a +4 bonus to this check due to the stability of your six legs. The target can escape with the normal Escape Artist or Strength check for escaping your webs. You can release the web line at any time as a free action. You can also use the weblines as a rope.

### Wing Parry [Avian]

As a last resort, you can use your wings to parry enemy attacks.

**Prerequisites:** Avian, Combat Reflexes

**Benefit:** You may parry enemy blows with your wings. This damages your wings and inhibits your ability to fly, but may let you live to see another day. On any enemy attack that causes damage, you may sacrifice one of your attacks of opportunity for the round to attempt to deflect the blow with

your wings. Make an attack roll with your natural weapons. If your attack roll is greater than the attack roll that caused damage to you, you have parried the attack. If the first parry attempt fails, you can sacrifice a second attack of opportunity to make another attempt.

On each unsuccessful parry, you take no damage, but your wings are injured. Your flight speed drops by 20 ft. and your maneuverability class is reduced by one. Every 20 ft. of lost flight speed takes 8 days to heal naturally. Each day spent with no flying or use of your wings whatsoever counts as 2 days, as does each day in which you are tended by someone who makes a Heal check (DC 20). Minimum healing time is 4 days.

### Wingwielder [Avian]

You have learned to use your wings as defensive weapons in combat. They are almost like another pair of arms.

**Prerequisites:** Avian, Dex 13+

**Benefit:** You can attach a specially-designed shield to each of your wings. This wing shield can be made of wood (cost 20 gp, weight 5 lbs.) or steel (cost 60 gp, weight 6 lbs.). Each shield grants a +1 armor bonus to your AC. It takes a full round action to attach or detach a wing shield.

You cannot fly while using a shield in this manner. Furthermore, sunder attacks risk damaging your wings. Any sunder attack that causes more damage than necessary to destroy either of your wing shields inflicts the excess damage on you and also injures your wings. Your flight speed drops by 20 ft. and your maneuverability class is reduced by one. Every 20 ft. of lost flight speed takes 8 days to heal naturally. Each day spent with no flying or use of your wings whatsoever counts as 2 days, as does each day in which you are tended by someone who makes a Heal check (DC 20). Minimum healing time is 4 days.

## New Uses for Old Feats

A few of the core feats relating to using and controlling mounts need some clarifications when used in an aerial campaign.

**Mounted Combat:** This feat works as normal with flying mounts.

**Mounted Archery:** While the feat text specifically mentions horseback its benefits apply to all mounts, including flying ones.

**Ride-By Attack:** You may use this feat as described when riding a flying creature, but the mount may only attack in this manner if it has the Flyby feat.

**Spirited Charge:** The bonus damage from this feat applies when you use the charge action while riding a flying creature.

**Trample:** A flying mount may not use this feat unless it is walking on the ground or other solid surface.



# Equipment of the Skies

The aerial realms are rife with magic. Between surface-world wizards eager to carve out an isolated lair in which to study magic and the many elemental creatures that dwell amongst the winds, a greater percentage of the creatures found in the sky realms have magical abilities or practice the arcane arts than those on the world's surface. The creatures of the aerial realms have developed a variety of spells and magic items to help them deal with their environment. Some of these are designed to help aid flight, while others were created to defeat flying creatures and those monsters normally found amongst the clouds.

## Mundane Equipment

The following items are normally produced by communities that have frequent contact with aerial races, creatures that live amongst the clouds, or wizards and other explorers who travel through the air via magical means.

## Weapons (Personal)

**Bombs:** Often overlooked by neophyte adventurers, items designed and produced through the art of alchemy can prove quite useful during an adventure. As aerial creatures must often contend with dragons, wyverns, and other dangerous foes, they seek out every available advantage against them. Amongst civilized aerial or sky-going races, alchemical items such as flame bombs and gas spores are critical weapons against marauding beasts and pirates. Those items are described in more detail in their own entries; this entry explains the general use of bombs.

Designed to be dropped from above on to ground-based or lower-altitude targets, bombs are simple devices that deliver a variety of alchemical effects against their targets. Bombs are used in a manner similar to the drop net and drop spear. A bomb may be used by a flying creature at any point

during its movement. The creature simply lets go of the bomb when it is over its target. This attack counts as a standard action, but the creature may move both before and after it makes its attack. Creatures with the Shot On the Run feat attack as normal. Those without it suffer a –6 penalty to their attack when using a bomb in this manner. If the creature moves then attacks or vice versa, it does not suffer this penalty.

A creature must make a ranged touch attack to strike a target with a bomb in this manner. On a missed attack, treat a bomb as a grenadelike weapon. It scatters and detonates in its new target area.

A character who wishes to specialize in using bombs may take the Exotic Weapon Proficiency (bombs) feat. This ability applies to all the bomb types listed here. Otherwise, characters using these weapons suffer the standard –4 non-proficiency penalty.

**Drop Net:** This heavy mesh net is designed to be dropped by a flying creature to land on and entangle a creature on the ground or one flying at a lower altitude. When used to make an attack, the net functions much like a standard net. Resolve the attack in much the same way as a standard net except this type of net does not feature a trailing rope. Furthermore, while this net may only be used against targets directly below the attacker, it has a maximum range of 100 feet and a range increment of 20 feet.

The drop net may be used by a flying creature at any point during its movement. The creature simply lets go of the net when it is over its target. This attack counts as a standard action, but the creature may move both before and after it makes its attack. Creatures with the Shot On the Run feat attack as normal. Those without it suffer a –6 penalty to their attack when using the net in this manner. If the creature moves then attacks or vice versa, it does not suffer this penalty.

**Drop Spear:** This short, sharp steel projectile is heavily weighted towards its spear point end, making it an ideal weapon when dropped from altitude against ground targets

Personal Weapons								
Weapon	Cost	Dmg (S)	Dmg (M)	Dmg (L)	Crit	Rng. Inc.	Wgt.	Type
<i>Martial Weapons</i>								
<i>One-Handed Melee Weapons</i>								
Cutlass	10 gp	1d4	1d6	1d8	x2	–	4 lbs.	Slashing
<i>Ranged Weapons</i>								
Drop spear	4 gp	1d6	1d8	1d10	x3	20 ft.	6 lbs.	Piercing
<i>Exotic Weapons</i>								
<i>Ranged Weapons</i>								
Drop net	24 gp	Special	Special	Special	–	20 ft.	10 lbs.	–
Flame bomb	50 gp	2d6	2d6	2d6	–	10 ft.	4 lbs.	Fire
Gas spore, choking	25 gp	Special	Special	Special	–	10 ft.	3 lbs.	Special
Gas spore, concealing	15 gp	Special	Special	Special	–	10 ft.	4 lbs.	Special
Gravity harpoon	30 gp	–	1d6	1d8	x2	10 ft.	40 or 70 lbs.	Piercing
Harpoon	8 gp	1d6	1d8	1d10	x2	10 ft.	12 lbs.	Piercing

and low flying creatures. The drop spear is a primitive bomb used by humanoid flying creatures. The drop spear may be used by a flying creature at any point during its movement. The creature simply lets go of the spear when it is over its target, similar to how a drop net is used. This attack counts as a standard action, but the creature may move both before and after it makes its attack. Creatures with the Shot On the Run feat attack as normal. Those without it suffer a -6 penalty to their attack when using the spear in this manner. If the creature moves then attacks or vice versa, it does not suffer this penalty.

**Flame Bomb:** (See also the entry for bombs.) This projectile is a small sphere split into two separate hemispheres, each holding a different chemical mix, separated by a thin layer of waxed paper. When forcibly thrown against a target, the paper breaks and allows the two chemicals to combine, creating a fiery explosion as they react. A flame bomb explodes into a burst of flame that deals 2d6 fire damage to all creatures in a 10-foot spread around the point of impact. A Reflex save (DC 13) allows a creature to take half damage.

**Gas Spore, Choking:** (See also the entry for bombs.) This specialized bomb is a plaster sphere that contains a cloud of concentrated pepper gas. When the sphere shatters, it unleashes a thick cloud of gas that causes choking and coughing in living creatures. Anyone within a 10-foot spread of the bomb's impact location must make a Fortitude save (DC 13) or suffer a -1 circumstance penalty to attacks, checks, and saves as the gas distracts and disrupts their efforts. This penalty lasts for only 1d3 rounds before the gas dissipates.

**Gas Spore, Concealing:** (See also the entry for bombs.) Normally used to cover retreats or suppress enemy fire, this gas spore contains an alchemical mixture that transforms into a thick, billowing cloud when exposed to air. When this bomb shatters, it belches forth a cloud of smoke that blocks line of sight as per the spell *obscuring mist*. This cloud forms in a 30-foot spread around the bomb's point of impact and dissipates in 1d6 minutes.

**Gravity Harpoon:** This nasty weapon is used by large flyers at risk of being outmaneuvered by nimble attackers. The gravity harpoon is a wickedly barbed harpoon attached to a 200-foot length of lightweight chain. At the end of the chain is a heavy iron ball. The weight varies by size: the Medium version has a 30 lb. ball (total weight 40 lbs. including chain and harpoon) and the Large version has a 60 lb. ball (total weight 70 lbs.).

The harpoon is launched at the target in the usual manner, but it is not designed to wound (though it still does so incidentally). Instead, it is designed to embed itself in the target and be difficult to pull out, especially when the weight of the iron ball is tugging down on it. Once the target is hit, the attacker immediately kicks the iron ball overboard, if it has not already been jerked overboard by the attacker trying to

fly off. The iron ball then weighs down the flyer.

The weight of the gravity harpoon is added to the target's encumbrance. If the target's encumbrance exceeds his carrying capacity, he immediately crashes. The gravity harpoon can be removed in the air only by using a standard action to yank it out with the force of the iron ball tugging on it, which causes double the damage it inflicted on the first hit. Once the target has landed, it can be eased out carefully, but this takes one minute and requires a Heal check (DC 15). Failure means it causes damage equal to the initial hit.

**Harpoon:** A common maritime weapon adapted for aerial use, a harpoon is a heavy steel spear with a wicked, barbed tip. In combat, the harpoon is used to spear and catch opponents. This weapon's barbed point snarls the creature's flesh and makes it very difficult to remove the weapon. Normally, a warrior armed with a harpoon hangs on to a length of chain or rope attached to the harpoon's shaft. After throwing the weapon and catching an opponent, he can then drag his foe near using the chain.

In combat, a creature hit by a harpoon must make a Reflex save (DC equal to the harpoon's attack roll). If the creature has a natural or armor bonus to AC, he may add that to his saving throw. The harpoon may injure the target but deflect off his heavy armor or fail to penetrate deeply. On a successful save, the harpoon fails to hit with enough force to catch the target with its barbed point (but it still causes damage). On a failed save, the target is caught. As a standard action, the attacker may attempt an opposed Strength check against his victim in order to pull him closer. If the attacker succeeds, he pulls his victim 10 feet towards him. The victim may remove the harpoon by using a full round action and taking normal damage as he tears the harpoon from his flesh. A Heal skill check (DC 15) is required to remove the harpoon without causing damage. Using the Heal skill in this manner takes 1 minute.

## Weapons (Sky Ship)

**Ballista:** A Medium size creature crewing a ballista suffers a -4 penalty to attack rolls, and a Small creature suffers a -6 penalty. A creature smaller than Large size takes two full-round actions to reload the ballista after firing. For full details on ballista fire, see Chapter 3: Adventures in the DMG, under the Urban Adventures section.

**Ballista, whirling:** A whirling ballista appears to be three ballistae mounted at right angles to each other, but it is actually a single complex device. The whirling ballista uses an advanced gear-and-crank mechanism that rotates the entire device on its axis after each shot. As it rotates, the gears also cock the just-fired ballista stock, which is then reloaded by the crew so that it is ready when rotated into

### Sky Ship Weapons

Item	Cost	Damage	Critical	Range Increment	Typical Crew
Ballista	500 gp	3d8	19-20/x2	120 ft.	1
Ballista, whirling	2,400 gp	3d8	19-20/x2	120 ft.	1
Catapult, heavy	800 gp	6d6	—	200 ft. (100 ft. min)	4
Catapult, light	550 gp	4d6	—	150 ft. (100 ft. min)	2
Dart launcher	1,000 gp	1d6	20/x2	80 ft.	3
Flame bolt	150 gp	2d8+2d6	19-20/x2	100 ft.	—
Ramming spikes	100 gp/5 ft.	+1d8	—	—	—

position. It effectively cuts the work in half and enables a continual rate of fire. It takes only one standard action to reload a whirling ballista after firing.

The only downside is the risk of a jam; on any attack roll of a natural 1, the machine stops working. It can then be fixed only with a Profession (engineer) check (DC 15) or Profession (sky sailor) check (DC 20). Each attempt takes one full-round action and the repairman can continue until the weapon is fixed.

Whirling ballistae are quite rare due to their complexity and the construction difficulty. They are generally available only in large ports. Even then they must be custom-built.

**Catapult:** A heavy catapult occupies a space 15 feet across, while a light catapult occupies a space 10 feet across. It takes four full-round actions to reload and re-aim a heavy catapult. A crew of four can do this in one full round. A catapult crew can fire indirect shots, possibly hitting targets out of their line of sight. For full details on catapult fire, see Chapter 3: Adventures in the DMG, under the Urban Adventures section.

**Dart Launcher:** A dart launcher is designed for attacking the crew of enemy vessels. It is almost useless against sky ships but devastating against exposed crew. The dart launcher is a burst weapon that fires a hail of darts. The darts affect everything in a 20-foot radius from the point of impact. Targets within the area of effect can make a Reflex save (DC 15) to take half damage.

It takes three full-round actions to reload a dart launcher. The reloading process is quite slow due to the number of darts that must be positioned properly.

**Flame Bolt:** This is a special ballista bolt that has a large flame bomb (as described on page 30) fixed in its point. It does slightly less piercing damage than a normal ballista bolt but explodes in a ball of flame that inflicts 2d6 fire damage to anything within 10 feet, as a flame bomb. A Reflex save (DC 13) reduces this damage by half. The indicated price is per bolt.

**Ramming Spikes:** These can be fitted to any vessel at the cost of 100 gp per 5 ft. of coverage. They are typically fixed across the entire length of the vessel's front. They must be fitted to the full length of any given side to be effective. The vessel then inflicts an extra 1d8 damage on any rams from that side, even when another ship initiates the ram. For example, a sky ship with ramming spikes on its rear would cause 1d8 extra damage to an enemy ship that rammed it from the rear.

## Armor

**Flight Armor:** Maneuverability is king in the air, yet humanoid creatures with flying ability still appreciate the protection offered by a stiff breastplate or a stout chainmail shirt. Flight armor is specifically designed for creatures with wings. It is forged to offer protection while leaving enough open space for wings or other flying appendages to function without interference. Any light or medium armor may be forged in this manner. Flight armor improves an armor type's skill check penalty by 1 and decreases its weight by one quarter and its armor bonus by 1. Flying creatures may move through the air at their normal maneuverability while wearing flight armor, though their speed is reduced as usual while wearing medium armor. Flight armor costs 25% more than usual.

## Adventuring Gear

**Airman's saddle:** This special military exotic saddle is designed to keep flyers as safe as possible while they're on their mounts. An airman's saddle braces the rider just like a military saddle, granting a +2 circumstance bonus to Ride checks related to staying in the saddle. In addition, the saddle keeps the wearer securely lashed in, giving the rider a 95% chance to stay in the saddle if knocked unconscious, even when the mount is performing aerial maneuvers (compared to 75% for a standard military saddle, and 50% for a normal saddle). To guarantee this security, the airman's saddle requires a great deal of preparation to lace up properly, and a second person must help. To be harnessed properly, the rider must have an assistant, and the whole process takes two minutes. A rider with no assistant can partially strap himself in, but the protection is no better than a standard military saddle (75% chance to stay in the saddle).

**Airman's wings:** For military sky ships, it is not sufficient to harness a soldier to a safety line and keep him secure aboard his sky ship. When boarding actions are needed, it is necessary to move soldiers from the safety of their own sky ship across the open air and onto the deck of the enemy ship. This can be dangerous, especially if a gangplank falls during the raid, sending soldiers hurtling to their deaths.

The airman's wings make boarding actions much easier. These extremely light "wings" are actually flaps of woven spider silk that are strung between the wrists and ankles of the airmen who wear them. While they are useless on the

Armor	Cost	Flight Armor							
		Armor Bonus	Max Dex	Check Penalty	Spell Failure	Speed (80 ft.)	Speed (60 ft.)	Speed (40 ft.)	Weight
<i>Light armor</i>									
Flight leather	13 gp	+1	+6	0	10%	80 ft.	60 ft.	40 ft.	11.5 lb.
Flight studded leather	32 gp	+2	+5	0	15%	80 ft.	60 ft.	40 ft.	15 lb.
Flight chain shirt	125 gp	+3	+4	-1	20%	80 ft.	60 ft.	40 ft.	19 lb.
<i>Medium armor</i>									
Flight hide	19 gp	+2	+4	-2	20%	55 ft.	40 ft.	30 ft.	19 lb.
Flight scale mail	63 gp	+3	+3	-3	25%	55 ft.	40 ft.	30 ft.	22.5 lb.
Flight chainmail	188 gp	+4	+2	-4	30%	55 ft.	40 ft.	30 ft.	30 lb.
Flight breastplate	250 gp	+4	+3	-3	25%	55 ft.	40 ft.	30 ft.	22.5 lb.



## Adventuring Gear

Equipment	Cost	Weight
Airman's saddle	150 gp	45 lbs.
Airman's wings	300 gp	2 lbs.
Auger, portable	30 gp	10 lbs.
Backpack autogyro	600 gp	15 lbs.
Cling hooks	6 gp	2 lbs.
Drop line and gear	80 gp	1 lbs.
Signal mirrors	200 gp	2 lbs.
Signal plume	15 gp	—
Spring quiver	60 gp	2 lbs.
Wrist vial	5 gp	—

ground, they provide a perfect means for gliding from one location to another, provided they don't have to cover a great distance.

Gliding characters have a flying speed of 50 feet with average maneuverability. They must use their full 50 feet of speed each round; there is no way to slow down. For every 10 feet traveled through the air, the glider descends by 5 feet. Someone wearing these wings may take no other actions during the round save staying aloft and steering the wings — he cannot attack, cast spells, use psionics, or undertake any other action.

The wings provide no impediment to combat or movement on the ground, though they may affect specific certain actions; use common sense. Removing them takes a standard action. They are quite fragile and are destroyed by even a single hit point of damage from fire. Other forms of attack must cause 6 hit points of damage to destroy them, though they are rendered unusable after only one point of damage.

**Auger, portable:** This dwarven device is designed for drilling holes through solid wood. In the air is it used for penetrating sky ship hulls. The drill has a hollow bit, and is fitted with a system of complex gears that amplify the power generated through the hand crank. A normal user can drill a hole 2 feet wide through 3" thick wood in about 5 minutes.

**Backpack autogyro:** This gnomish creation is considered complicated, noisy, and inefficient by denizens of the air realms, but generally regarded as ingenious by landlubbers. It is a large metal backpack filled with gears. A metal strut extends downward to position two pedals underneath the wearer's feet. A long pole sticks straight up out of the backpack, and four wing-like rotors flop down from it.

A backpack autogyro allows the wearer to fly by pedaling furiously. The gears in the backpack spin the rotors at a great multiple of the wearer's pedaling speed, but it still takes an enormous amount of effort to achieve flight. Moreover, the position of the pedals interferes with the user's walking (they're literally located directly under his feet), and they can't be used on the ground. The only way to launch a backpack autogyro is to jump off a cliff or ledge and start pedaling, which is a terrifying proposition to most new users.

Nonetheless, the backpack works. Someone wearing a backpack autogyro gains a fly speed of 30 ft. (maneuverability clumsy), plus an additional +5 ft. speed for every full +4 Strength bonus they have. A user can only take off leaping from a height of 50 feet or more. While flying the wearer's arms are used to direct the machine, so all four of his limbs are fully occupied during flight.

A backpack autogyro must be custom fitted to each buyer, lest the pedals be too short or the rotors too heavy.

**Cling hooks:** Originally pioneered by rogues for use during jobs that require hanging around for extended periods of time, cling hooks attach to the knees and elbows of the user with several leather straps. While in place, the straps slow climbing movement by one-half, but provide a +10 circumstance bonus to any Climb skill checks made while the wearer is attempting to climb up a wooden surface.

By digging the blades into the wood (or any similar material, as judged by the GM), the wearer is able to slowly crawl up the sides of a sky ship. By reducing movement to a mere 5 feet per round, the wearer can even attempt to crawl upside-down across the bottom of a sky ship (Climb DC 35).

If the wearer chooses he can also cling to the side of a sky ship or similar structure by digging the blades in and simply relaxing. The wearer can hang indefinitely like this, though a Climb check may be necessary if the sky ship begins moving rapidly or takes extreme maneuvers.

**Drop line and gear:** This gear includes a harness, a collection of grooved wheels with a handle, and a sturdy hemp line that is threaded through the wheels. The drop line is attached to a target via a grappling hook or other method and secured at the originating end, then the person wearing the harness zips across the line. This sort of equipment is complicated and difficult to manufacture, but quite useful for sky sailors who need to board enemy ships.

The drop line can support up to 300 pounds. The rate of descent across a drop line ranges from 50 ft. to 5 ft. per round, a rate which the user can control with the handle. Ascending a drop line requires the user to pull himself along hand-over-hand at a maximum speed of 10 ft. per round (20 ft. with a double move; can't charge).

**Signal mirrors:** This complicated set of mirrors and rotating louvers is used to communicate over great distances, particularly between sky ships. The length of bursts of reflected sunlight and the spaces between the bursts forms a crude code used to convey signals between two points.

When the sky is not overcast and the sun is above the horizon and visible from the signaling mirror's location, the mirror can be seen up to 5 miles distant. When the sky is overcast, or during the dawn and dusk hours, this distance is reduced to roughly a mile. It requires a full round action to transmit a message of up to 20 words, and receiving a message takes a full round action as well.

Learning the code for signaling mirrors is just like learning a language, and a new language must be taken for each different code you wish to learn. Different races have their own codes, some of which are military secrets. Pirates have their own code language.

**Signal plume:** Few things are more frightening than getting knocked overboard while serving on a sky ship. While there are many ways to stay in the air after being knocked off the deck, after a heated battle your sky ship might drift off without you. The signal plume is a self-igniting bundle of powder that, when broken open, creates a brilliant red cloud of smoke. This smoke is not thick (it does not obscure vision) but can automatically be seen by any sky ship within 500 yards of its location, and provides a +4 circumstance bonus to any attempts to spot you at a greater distance. Officers always wear signal plumes and most crewmen save their silver pieces up to purchase one. If used on the ground, the plume is not nearly as impressive as when

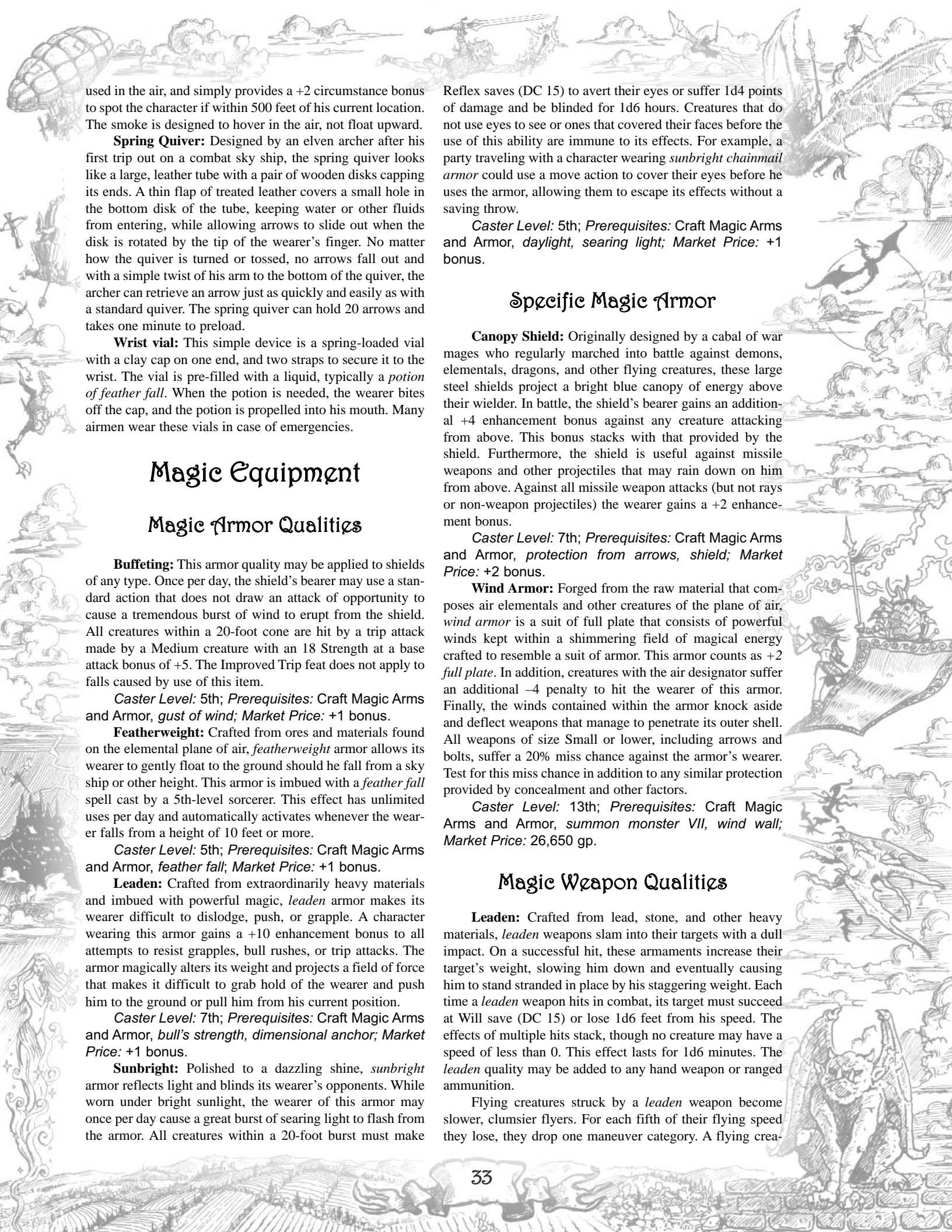

used in the air, and simply provides a +2 circumstance bonus to spot the character if within 500 feet of his current location. The smoke is designed to hover in the air, not float upward.

**Spring Quiver:** Designed by an elven archer after his first trip out on a combat sky ship, the spring quiver looks like a large, leather tube with a pair of wooden disks capping its ends. A thin flap of treated leather covers a small hole in the bottom disk of the tube, keeping water or other fluids from entering, while allowing arrows to slide out when the disk is rotated by the tip of the wearer's finger. No matter how the quiver is turned or tossed, no arrows fall out and with a simple twist of his arm to the bottom of the quiver, the archer can retrieve an arrow just as quickly and easily as with a standard quiver. The spring quiver can hold 20 arrows and takes one minute to preload.

**Wrist vial:** This simple device is a spring-loaded vial with a clay cap on one end, and two straps to secure it to the wrist. The vial is pre-filled with a liquid, typically a *potion of feather fall*. When the potion is needed, the wearer bites off the cap, and the potion is propelled into his mouth. Many airmen wear these vials in case of emergencies.

## Magic Equipment

### Magic Armor Qualities

**Buffeting:** This armor quality may be applied to shields of any type. Once per day, the shield's bearer may use a standard action that does not draw an attack of opportunity to cause a tremendous burst of wind to erupt from the shield. All creatures within a 20-foot cone are hit by a trip attack made by a Medium creature with an 18 Strength at a base attack bonus of +5. The Improved Trip feat does not apply to falls caused by use of this item.

**Caster Level:** 5th; **Prerequisites:** Craft Magic Arms and Armor, *gust of wind*; **Market Price:** +1 bonus.

**Featherweight:** Crafted from ores and materials found on the elemental plane of air, *featherweight* armor allows its wearer to gently float to the ground should he fall from a sky ship or other height. This armor is imbued with a *feather fall* spell cast by a 5th-level sorcerer. This effect has unlimited uses per day and automatically activates whenever the wearer falls from a height of 10 feet or more.

**Caster Level:** 5th; **Prerequisites:** Craft Magic Arms and Armor, *feather fall*; **Market Price:** +1 bonus.

**Leaden:** Crafted from extraordinarily heavy materials and imbued with powerful magic, *leaden* armor makes its wearer difficult to dislodge, push, or grapple. A character wearing this armor gains a +10 enhancement bonus to all attempts to resist grapples, bull rushes, or trip attacks. The armor magically alters its weight and projects a field of force that makes it difficult to grab hold of the wearer and push him to the ground or pull him from his current position.

**Caster Level:** 7th; **Prerequisites:** Craft Magic Arms and Armor, *bull's strength*, *dimensional anchor*; **Market Price:** +1 bonus.

**Sunbright:** Polished to a dazzling shine, *sunbright* armor reflects light and blinds its wearer's opponents. While worn under bright sunlight, the wearer of this armor may once per day cause a great burst of searing light to flash from the armor. All creatures within a 20-foot burst must make

Reflex saves (DC 15) to avert their eyes or suffer 1d4 points of damage and be blinded for 1d6 hours. Creatures that do not use eyes to see or ones that covered their faces before the use of this ability are immune to its effects. For example, a party traveling with a character wearing *sunbright chainmail armor* could use a move action to cover their eyes before he uses the armor, allowing them to escape its effects without a saving throw.

**Caster Level:** 5th; **Prerequisites:** Craft Magic Arms and Armor, *daylight*, *searing light*; **Market Price:** +1 bonus.

### Specific Magic Armor

**Canopy Shield:** Originally designed by a cabal of war mages who regularly marched into battle against demons, elementals, dragons, and other flying creatures, these large steel shields project a bright blue canopy of energy above their wielder. In battle, the shield's bearer gains an additional +4 enhancement bonus against any creature attacking from above. This bonus stacks with that provided by the shield. Furthermore, the shield is useful against missile weapons and other projectiles that may rain down on him from above. Against all missile weapon attacks (but not rays or non-weapon projectiles) the wearer gains a +2 enhancement bonus.

**Caster Level:** 7th; **Prerequisites:** Craft Magic Arms and Armor, *protection from arrows*, *shield*; **Market Price:** +2 bonus.

**Wind Armor:** Forged from the raw material that composes air elementals and other creatures of the plane of air, *wind armor* is a suit of full plate that consists of powerful winds kept within a shimmering field of magical energy crafted to resemble a suit of armor. This armor counts as +2 *full plate*. In addition, creatures with the air designator suffer an additional -4 penalty to hit the wearer of this armor. Finally, the winds contained within the armor knock aside and deflect weapons that manage to penetrate its outer shell. All weapons of size Small or lower, including arrows and bolts, suffer a 20% miss chance against the armor's wearer. Test for this miss chance in addition to any similar protection provided by concealment and other factors.

**Caster Level:** 13th; **Prerequisites:** Craft Magic Arms and Armor, *summon monster VII*, *wind wall*; **Market Price:** 26,650 gp.

### Magic Weapon Qualities

**Leaden:** Crafted from lead, stone, and other heavy materials, *leaden* weapons slam into their targets with a dull impact. On a successful hit, these armaments increase their target's weight, slowing him down and eventually causing him to stand stranded in place by his staggering weight. Each time a *leaden* weapon hits in combat, its target must succeed at Will save (DC 15) or lose 1d6 feet from his speed. The effects of multiple hits stack, though no creature may have a speed of less than 0. This effect lasts for 1d6 minutes. The *leaden* quality may be added to any hand weapon or ranged ammunition.

Flying creatures struck by a *leaden* weapon become slower, clumsier flyers. For each fifth of their flying speed they lose, they drop one maneuver category. A flying crea-



ture reduced to less than the minimum speed it must move each round due to its maneuver rating immediately crashes to the ground, taking falling damage as appropriate. These weapons have no effect against sky ships, though creatures flying through the use of spells or magic items are vulnerable to them.

**Caster Level:** 13th; **Prerequisites:** Craft Magic Arms and Armor, *slow, reverse gravity*; **Market Price:** +3 bonus.

**Far Reaching:** In an aerial environment, it is rather common on a clear day for two combatants to sight each other at ranges far beyond weaponry and spells. *Far reaching* weapons seek to rectify that state. These weapons are enchanted to unerringly seek out targets at incredibly great distances. When thrown or fired, a *far reaching* weapon may target any opponent its user can see no matter what the range. Thus, a spear could theoretically be thrown several miles while an arrow could fly for thousands of feet. These weapons never sustain a penalty for range, though all other modifiers apply as normal. The *far reaching* quality may only be applied to thrown weapons and ammunition, such as arrows, bolts, or sling bullets. Note that unless the weapon also has the *returning* quality, recovering a weapon thrown several miles may be difficult.

**Caster Level:** 16th; **Prerequisites:** Craft Magic Arms and Armor, *fly*; **Market Price:** +4 bonus.

**Penetrating:** Thrown weapons and ammunition with this quality are usually forged from steel, even arrow fletching, spear shafts, and other portions normally crafted from lighter materials. *Penetrating* weapons fly with incredible speed, allowing them to punch through even the toughest materials with ease. A *penetrating* weapon ignores an object's hardness and deals an additional 1d6 damage on a hit, due to its high speed. This damage is not multiplied on a critical hit. Only thrown weapons or ranged weapon ammunition may be granted this quality.

**Caster Level:** 5th; **Prerequisites:** Craft Magic Arms and Armor, *haste, fly*; **Market Price:** +1 bonus.

## Specific Magic Weapons



**Arrow of the Hawk:** At first glance, this shaft appears to be a small, wooden idol crafted to resemble an arrowhawk. Closer inspection reveals a notch carved into the end of the idol, making it suitable for firing from a bow. When used in battle, the *arrow of the hawk* transforms into an adult arrowhawk that streaks towards its target and attacks. The arrowhawk attacks as if it charged its target on the firer's initiative count. Resolve this attack on the action used to fire the arrow. For the rest of the combat, the arrowhawk acts simultaneously with its user. The creature continues to fight for 9 rounds, after which it disappears. It attacks the target it was used against and moves on to its users' other foes should its initial opponent fall.

**Caster Level:** 9th; **Prerequisite:** Craft Magic Arms and Armor, *animal growth, fabricate, summon monster V*; **Market Price:** 2,250 gp per arrow.

**Fondek's Blasting Tube:** This 4-foot-long hollow steel tube is closed at one end and fitted with a long wooden stock. Once every four rounds, the tube may be used to unleash a blast of sorcerous power at a target. The user aims the tube at his opponent and makes a ranged touch attack. On a hit, he



deals 2d8 points of fire damage as the tube belches forth a small, burning projectile. The blasting tube counts as a +3 weapon for purposes of damage reduction but does not gain an enhancement bonus to attack or damage. The blasting tube counts as a Large weapon. It is too unwieldy for Small characters and requires two hands for Medium size characters to wield. The blast tube has a maximum range of 200 feet and a range increment of 40 feet.

**Caster Level:** 11th; **Prerequisites:** Craft Magic Arms and Armor, *flame arrow, true strike*; **Market Price:** 4,000 gp.

**Fondek's Whirling Blast Tubes:** The weaponsmith Fondek, pleased with his initial creation but desiring to deliver even more havoc to the battlefield, created this weapon as a natural outgrowth of his original invention. The whirling blasting tubes are merely six of his original weapons bound together around a central, rotating core. In battle, the user works a crank that rotates the core and activates each blast tube in turn. When firing this weapon, the user may opt to use up to all six tubes against the same target. Otherwise, treat this weapon as a blast tube as described above. Each individual tube may be used once every four rounds. Keep track of each tube's use separately to determine when it may be used again.

**Caster Level:** 5th; **Prerequisites:** Craft Magic Arms and Armor, *flame arrow, haste, true strike*; **Market Price:** 30,000 gp.

## Rods, Staves, and Wands

**Lightning Rod:** This steel or iron cylinder is typically a half-inch wide and three feet long. The lightning rod has an unmistakable bluish tinge to its metal, and when closely inspected a faint pattern of lightning bolts emerges in its color and grain. The lightning rod absorbs electrical attacks and stores their energy for later use. Whenever the rod's bearer is targeted by an attack, spell, supernatural power, or other effect that deals electrical damage, there is a 25% chance the rod absorbs the damage and leaves its owner unharmed. When the rod absorbs damage, it stores part of it as electrical energy that may be discharged later. For every 6 full points of damage the rod absorbs, it stores 1d6 worth of electrical damage. A rod may store a maximum of 20d6 worth of energy. Once it is full, it may no longer absorb electrical damage. Furthermore, if an attack causes the rod to fill its storage capability any damage that rod cannot absorb affects the rod's user as normal.

The rod may be wielded as a weapon. If its user succeeds at a touch attack against a target in metal armor or a standard attack against any other target, he may deal up to 3d6 electrical damage with the rod. Each die of damage inflicted in this manner subtracts 1 die from the rod's currently stored charge.

The rod automatically absorbs electrical spells that are cast directly upon it. For example, a sorcerer who wishes to charge his lightning rod could repeatedly cast *shocking grasp* and discharge his spell by touching the rod.

**Caster Level:** 11th; **Prerequisites:** Craft Rod, *lightning bolt, protection from elements, shocking grasp*; **Market Price:** 25,000 gp.

**Staff of the Four Winds:** This long, thin staff is the same color as the sky. Silver caps at both the staff's ends are



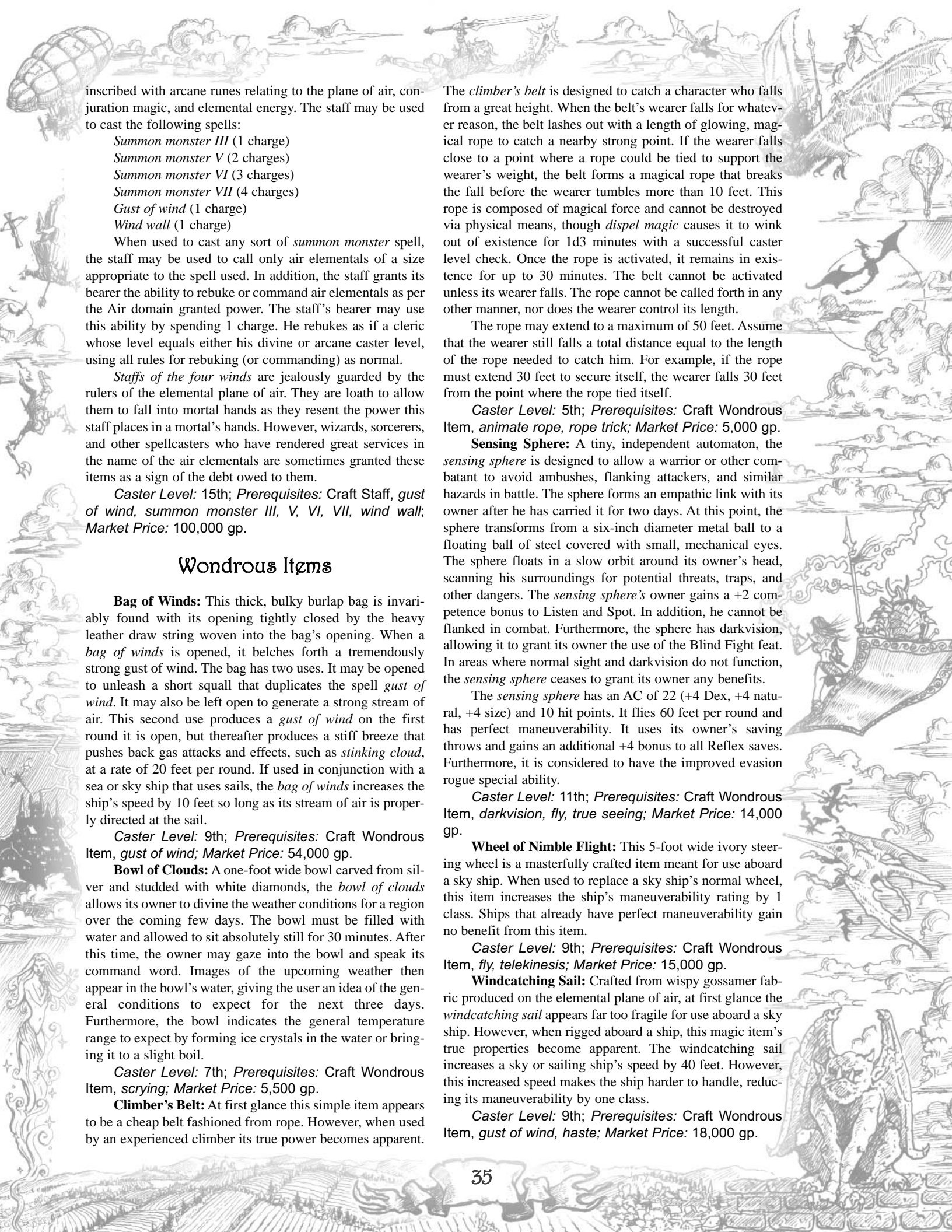

inscribed with arcane runes relating to the plane of air, conjuration magic, and elemental energy. The staff may be used to cast the following spells:

*Summon monster III* (1 charge)  
*Summon monster V* (2 charges)  
*Summon monster VI* (3 charges)  
*Summon monster VII* (4 charges)  
*Gust of wind* (1 charge)  
*Wind wall* (1 charge)

When used to cast any sort of *summon monster* spell, the staff may be used to call only air elementals of a size appropriate to the spell used. In addition, the staff grants its bearer the ability to rebuke or command air elementals as per the Air domain granted power. The staff's bearer may use this ability by spending 1 charge. He rebukes as if a cleric whose level equals either his divine or arcane caster level, using all rules for rebuking (or commanding) as normal.

*Staffs of the four winds* are jealously guarded by the rulers of the elemental plane of air. They are loath to allow them to fall into mortal hands as they resent the power this staff places in a mortal's hands. However, wizards, sorcerers, and other spellcasters who have rendered great services in the name of the air elementals are sometimes granted these items as a sign of the debt owed to them.

**Caster Level:** 15th; **Prerequisites:** Craft Staff, *gust of wind*, *summon monster III*, *V*, *VI*, *VII*, *wind wall*;  
**Market Price:** 100,000 gp.

## Wondrous Items

**Bag of Winds:** This thick, bulky burlap bag is invariably found with its opening tightly closed by the heavy leather draw string woven into the bag's opening. When a *bag of winds* is opened, it belches forth a tremendously strong gust of wind. The bag has two uses. It may be opened to unleash a short squall that duplicates the spell *gust of wind*. It may also be left open to generate a strong stream of air. This second use produces a *gust of wind* on the first round it is open, but thereafter produces a stiff breeze that pushes back gas attacks and effects, such as *stinking cloud*, at a rate of 20 feet per round. If used in conjunction with a sea or sky ship that uses sails, the *bag of winds* increases the ship's speed by 10 feet so long as its stream of air is properly directed at the sail.

**Caster Level:** 9th; **Prerequisites:** Craft Wondrous Item, *gust of wind*; **Market Price:** 54,000 gp.

**Bowl of Clouds:** A one-foot wide bowl carved from silver and studded with white diamonds, the *bowl of clouds* allows its owner to divine the weather conditions for a region over the coming few days. The bowl must be filled with water and allowed to sit absolutely still for 30 minutes. After this time, the owner may gaze into the bowl and speak its command word. Images of the upcoming weather then appear in the bowl's water, giving the user an idea of the general conditions to expect for the next three days. Furthermore, the bowl indicates the general temperature range to expect by forming ice crystals in the water or bringing it to a slight boil.

**Caster Level:** 7th; **Prerequisites:** Craft Wondrous Item, *scrying*; **Market Price:** 5,500 gp.

**Climber's Belt:** At first glance this simple item appears to be a cheap belt fashioned from rope. However, when used by an experienced climber its true power becomes apparent.

The *climber's belt* is designed to catch a character who falls from a great height. When the belt's wearer falls for whatever reason, the belt lashes out with a length of glowing, magical rope to catch a nearby strong point. If the wearer falls close to a point where a rope could be tied to support the wearer's weight, the belt forms a magical rope that breaks the fall before the wearer tumbles more than 10 feet. This rope is composed of magical force and cannot be destroyed via physical means, though *dispel magic* causes it to wink out of existence for 1d3 minutes with a successful caster level check. Once the rope is activated, it remains in existence for up to 30 minutes. The belt cannot be activated unless its wearer falls. The rope cannot be called forth in any other manner, nor does the wearer control its length.

The rope may extend to a maximum of 50 feet. Assume that the wearer still falls a total distance equal to the length of the rope needed to catch him. For example, if the rope must extend 30 feet to secure itself, the wearer falls 30 feet from the point where the rope tied itself.

**Caster Level:** 5th; **Prerequisites:** Craft Wondrous Item, *animate rope*, *rope trick*; **Market Price:** 5,000 gp.

**Sensing Sphere:** A tiny, independent automaton, the *sensing sphere* is designed to allow a warrior or other combatant to avoid ambushes, flanking attackers, and similar hazards in battle. The sphere forms an empathic link with its owner after he has carried it for two days. At this point, the sphere transforms from a six-inch diameter metal ball to a floating ball of steel covered with small, mechanical eyes. The sphere floats in a slow orbit around its owner's head, scanning his surroundings for potential threats, traps, and other dangers. The *sensing sphere's* owner gains a +2 competence bonus to Listen and Spot. In addition, he cannot be flanked in combat. Furthermore, the sphere has darkvision, allowing it to grant its owner the use of the Blind Fight feat. In areas where normal sight and darkvision do not function, the *sensing sphere* ceases to grant its owner any benefits.

The *sensing sphere* has an AC of 22 (+4 Dex, +4 natural, +4 size) and 10 hit points. It flies 60 feet per round and has perfect maneuverability. It uses its owner's saving throws and gains an additional +4 bonus to all Reflex saves. Furthermore, it is considered to have the improved evasion rogue special ability.

**Caster Level:** 11th; **Prerequisites:** Craft Wondrous Item, *darkvision*, *fly*, *true seeing*; **Market Price:** 14,000 gp.

**Wheel of Nimble Flight:** This 5-foot wide ivory steering wheel is a masterfully crafted item meant for use aboard a sky ship. When used to replace a sky ship's normal wheel, this item increases the ship's maneuverability rating by 1 class. Ships that already have perfect maneuverability gain no benefit from this item.

**Caster Level:** 9th; **Prerequisites:** Craft Wondrous Item, *fly*, *telekinesis*; **Market Price:** 15,000 gp.

**Windcatching Sail:** Crafted from wispy gossamer fabric produced on the elemental plane of air, at first glance the *windcatching sail* appears far too fragile for use aboard a sky ship. However, when rigged aboard a ship, this magic item's true properties become apparent. The windcatching sail increases a sky or sailing ship's speed by 40 feet. However, this increased speed makes the ship harder to handle, reducing its maneuverability by one class.

**Caster Level:** 9th; **Prerequisites:** Craft Wondrous Item, *gust of wind*, *haste*; **Market Price:** 18,000 gp.

## Chapter Two

# Aerial Combat

Combat in the air is a nasty, brutish, and short affair. One devastating hit can send a combatant tumbling from the sky to meet his end. A blow that would only stagger a warrior on the ground can be the strike that ends an aerial battle.

These rules expand the options available to aerial combatants and also provide guidelines for using standard combat actions in aerial combat. You should be familiar with the standard rules for aerial movement, as these rules use them as the basic foundation for maneuver and combat. Before you read any further in this section, review the "Moving in Three Dimensions" section of Chapter 2 in the DMG. Minimum forward speed and maneuverability play a large part in aerial combat, and you'll have to keep them in mind as you read what follows.

## Aerial Initiative

Initiative works in aerial combat much the same way as it does in standard combat, except for one important difference. Flying creatures with an Intelligence of 8 or more roll initiative and take all their actions separately from their rider. Otherwise, the rider rolls initiative both for himself and his mount. If the rider chooses to allow his mount to fly without direction, the mount moves on its initiative count and the rider may use his actions as normal. Otherwise, a rider must use a move-equivalent action to direct his mount as normal. In this case, the mount delays its action to the rider's count or moves on the rider's initiative, as appropriate. Remember that a Ride check may be necessary for mounts that are not trained for combat.

## Facing

Unlike in standard combat, in air combat the direction in which a flying creature points is often extremely important. Facing determines which direction the creature must move and dictates maneuvers for flyers with average, poor, or clumsy maneuverability.

A flying creature can only attack a creature in its front arc. A creature's front arc extends in a straight line to the right and left of its current position and all areas extending out from that line in the direction of the creature's current facing. The remaining area behind the creature is its rear arc. These flyers cannot simply turn around to confront an enemy that approaches from the rear, as per the standard d20 flight maneuverability rules.

Creatures with perfect and good flight maneuverability may hover in place. These creatures have neither a front or rear arc. Much like ground combatants, they can respond to threats and direct their attacks in any direction.

A creature that attacks an enemy while in its rear arc is considered to have flanked its target. Flying creatures with levels in barbarian or rogue gain the benefit of their uncanny dodge ability when attacked from their rear arc in aerial combat. These nimble flyers are capable of tracking opponents in their rear arc and responding to their attacks.

## Abstract Movement

The aerial movement rules work best with miniatures and a battlemat. However, if you prefer to game without these tools you may prefer to use an abstract system of determining each creature's relative position. At the start of each round, each flying creature makes a Dexterity check or its rider makes a Ride check. These checks are modified as per the table below:

Maneuverability	Modifier
Perfect	+8
Good	+4
Average	+0
Poor	-4
Clumsy	-8

When a creature takes its action, it may choose to gain the benefit of attacking from the rear arc of any opponent who rolled lower on its Dexterity or Ride check.

While this rule removes some of the realism and tactical options from aerial combat, it does allow you to quickly resolve combats in the sky without ignoring the rather large advantage a highly agile flyer has over a ponderous opponent. Aerial combat is much more focussed on movement and maneuvering than ground fighting. Many creatures must move a minimum distance every round in order to remain aloft, making battles in the sky a much more fluid affair.

## Aerial Combat Options

This section covers modifications to the standard d20 special attack and damage modes. If an attack mode is not mentioned here, assume that it works without modification in air combat.

**Nonlethal Damage:** Nonlethal damage works as per the standard d20 rules. A staggered creature must use its partial action to move. Otherwise, it begins to fall from the sky (see Crashing, below). Obviously, an unconscious creature crashes to the ground.

**Aid Another:** In addition to making an attack roll against AC 10, a flying creature may attempt to buzz around an opponent, distracting it and disrupting its concentration.

To do this, the attacking flyer makes a Dex check (DC 10) or its rider may attempt a Ride check (DC 10) to gain the benefits of this action. This form of aid another is only effective against creatures with average, poor, or clumsy maneuverability. Only creatures with perfect or good maneuverability may attempt an aid another action in this manner. Other flyers are simply too unwieldy to attempt it.

**Bull Rush:** While on the ground a bull rush is an attempt to push back an opponent, in the air it is much riskier, and more lethal, attack. On sky ships, the bull rush is an effective method for knocking invaders overboard to their deaths. Between flying creatures, the bull rush becomes a de facto slam attack intended to disrupt an enemy's flight. The bull rushing creature rams its target, attempting to knock it from the sky. Use the rules for initiating a bull rush as normal. If the attacker beats the defender, both the attacker and defender take one die of damage for every full 10 feet of speed that the attacker normally has for flying. The die type of this attack is determined from the table below, based on the size of the attacker compared to the defender:

Attacker's Size, Compared to Defender	Defender's Damage	Attacker's Damage
3 or more sizes smaller	1	d10
1 or 2 sizes smaller	d4	d8
Same size as defender	d6	d6
1 or 2 sizes larger	d8	d4
3 or more sizes larger	d10	1

When a creature takes damage from a bull rush, whether it is the attacker or defender, it must make a Reflex save (DC 15) to avoid crashing. If the attacker and defender are not the same size, the larger of the two gains a +4 bonus to this save for each size increment by which it is larger than its opponent.

If the attacker fails to beat the defender, continue the attacker's movement forward as normal. The defender dodged above or below the attacker.

A bull rush by a sky ship crewman is also a good option for pushing opponents off of the ship.

**Grapple:** While it may seem odd, grappling is a good way to knock an opponent from the sky. The grappling rules work as normal, with one exception. If the attacker manages to grapple its opponent, any combatant that cannot hover in place (maneuverability average or worse) crashes to the ground. If both combatants can hover, resolve the grapple as normal. If only one can hover, the hovering grappler may choose to hold the non-hovering flyer aloft if it can bear the load of carrying it. Otherwise, the non-hovering grappler crashes if it loses the grapple.

**Overrun:** This combat option is not available in aerial combat. A flying creature can simply adjust its altitude to fly over or below an opponent.

**Trip Attack:** Trip attacks work very differently in the air. Rather than knock an opponent over, a trip attack unbalances a target and ruins its movement. On a successful trip attack, the target's movement is disturbed as he fights to regain his bearings. He counts as one maneuverability class worse on his next round of movement. Multiple trips do not stack. A clumsy creature that is tripped loses half its speed on its next action.

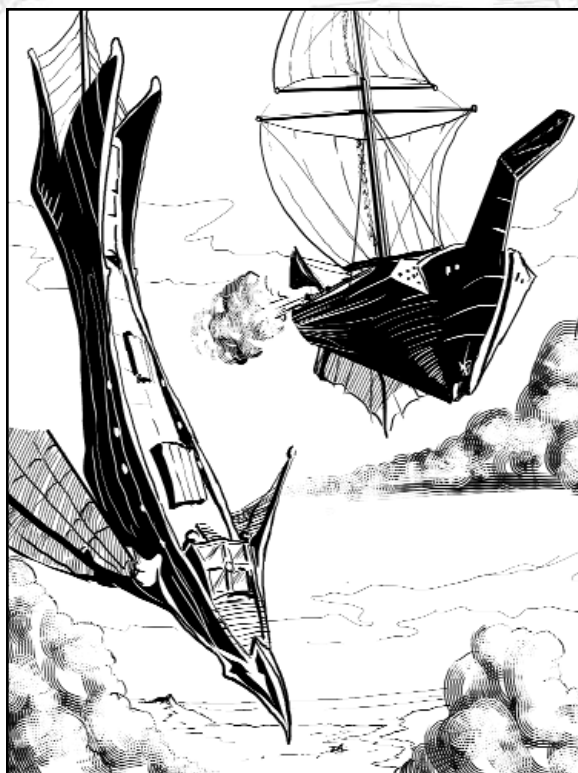

## Attacks of Opportunity

Flying creatures soar and swoop through the air, constantly shifting positions. The abstract nature of d20 combat makes it difficult to fully capture the constant shifts and motions of aerial combatants. Attacks of opportunity are used in aerial combat, but they can be difficult to track. The threatened area of an aerial creature is a three-dimensional space around it, including the space below and above it. Watch for attacks of opportunity involving all of the squares. Creatures with minimum forward movement due to low maneuverability are often exposed to attacks of opportunity whether they want them or not!

Many times it is easiest to treat aerial creatures as if they were fighting on the ground, and look for attacks of opportunity that way. For example, imagine a pegasus fighting a wyvern that's flying 5 feet below it. Although it may initially look like the attacks of opportunity will be difficult to evaluate, you can "tilt" the frame of reference and imagine the horizontal axis to be whatever straight line connects them. Then you can basically run the combat as if it were on a horizontal plane, as usual.

## Crashing

All creatures that lose the ability to fly immediately plummet to the ground. A falling creature falls 150 feet the first round and 300 feet each additional round. Once a falling creature hits the ground, it takes 1d6 points of damage for every 10 feet it fell (maximum 20d6). While falling, a creature or ship that still possesses the ability to fly, such as a creature knocked from the air by a bull rush attack, may make a Reflex save, Ride check, or Profession (sky sailor)





check (as appropriate; DC 20 +1 per round spent falling) to pull out of the dive.

Creatures with perfect maneuverability may automatically break out of a fall if they are conscious and still able to fly. Those with good maneuverability gain a +5 bonus to their save.

## Altitude



As combatants swoop and soar in the sky, they change their altitude and attack each other from above and below. Unlike ground battles, air combats are fought in a fully three-dimensional environment. This aspect of battles in the air can cause a lot of headaches for determining ranges between two fighters. There are a few different ways to handle this.

The first and easiest method is to ignore up and down movement. Simply fight battles on a two-dimensional grid as normal. Allow creatures to fly over each other while moving. If a character or creature flies straight up or down, note the distance between the flier and the level plane represented by the combat map. For example, if a creature flies 50 feet below the battle, note that down. Any creature shooting at a creature that has flown up or down uses the greater of the range between the two figures on the flat plane or the distance between the creature and the two-dimensional plane of the battle. While this is far from realistic, it is a simple way to quickly account for vertical movement.



Alternatively, if you have a calculator and you know how to use it, you can call on the trusty Pythagorean theorem. (Yes kids, RPGs can be educational.) According to our man Pythagoras, we can figure out the diagonal leg of a right triangle by squaring the distance of the other two sides, adding them together, and taking the square root of the sum. To apply this to aerial combat, square the distance between two figures on the two-dimensional plane of the battle, square the distance from the plane to the target, add those two values together, and take the square root. That is the actual range between the targets.

The Aerial Distance Table on the facing page summarizes these calculations rounded to 5 foot increments out to triangulated distances of 100 ft. by 200 ft. If this whole concept makes no sense, use the first, simpler option.

A third alternative is to use two battle maps when running an aerial combat. Lay out your combat grid as normal. This represents the horizontal plane in the fight. Your second map represents a vertical grid. By placing one piece for each flier on the two grids, you can easily keep track of their relative positions in both dimensions. To determine the range between two targets, simply count off the squares between them on the map where the two figures are furthest from each other.



On your vertical map, draw a line across the map around its center that indicates the position of your horizontal plane. The vertical distance between two figures is represented by their placement relative to the horizontal line representing your first battle mat. To indicate altitude, place figures relative to the horizontal line you drew. Figures above it soar above the horizontal map. Figures below it fly beneath it. To easily determine range, look at both maps and use the greater of the two ranges shown between two figures. Again, the range is not completely accurate, but it should satisfy most players who would like to account for vertical movement without using a calculator. If you want exact precision

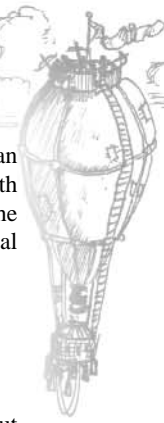

for combat ranges, you're welcome to talk to my man Pythagoras. Just don't forget your calculator. While the math may seem intimidating, any simple calculator can handle the math with ease and the precise calculations make vertical movement a bit more important.

## Weather

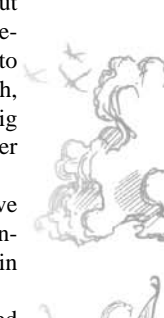

As a general rule, sky ships use magic to stay aloft, but depend on wind for propulsion. Some have their own independent means of propulsion, and all use arcane power to generate a limited degree of mobility. By and large, though, wind is the primary driver over long distances and has a big impact on sky ship mobility. By extension, then, the weather is an important factor for any sky sailor to consider.

Most air travel takes place at high altitudes, at or above cloud level, so the storms of the surface aren't a major concern for air travelers. Instead, forceful winds are the main concern.

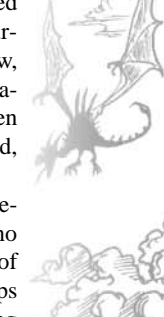

The table on the page 40 lists the effects of wind speed on sky ships of various sizes. Only when sky ships are journeying to the surface world will they be subject to rain, snow, sleet, hurricanes, or other surface weather. In those situations, use the applicable wind speed described below, then adjust for the impact of precipitation (fires are extinguished, snow may cause chills, etc.).

The effects of high winds are divided into three categories: safe, unsafe, and dangerous. Safe winds pose no threat to ships of that size. Unsafe winds affect only ships of poor or clumsy maneuverability; the captain of such ships must make a Profession (sky sailor) check to avoid crashing whenever the ship makes any movement other than traveling straight forward or simply standing in place. The DC is a reflection of the ship's size and the strength of the winds, as indicated on the table. Dangerous winds require every ship to make a check every round, regardless of movement.

A ship that fails its save starts to crash. The pilot loses control and the ship starts to dive at normal crashing speed (150 feet in the first round, and 300 feet every round thereafter). The pilot can recover from the crash only by making a Profession (sky sailor) check (DC 20 +1 per round spent falling). Even so, it is quite possible that crew or cargo may be tossed overboard as the ship enters a freefall.

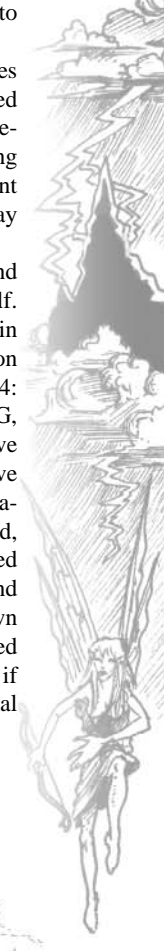

Note that wind speeds also affect flying creatures and any crew on the decks of ships, in addition to the ship itself. A character may be blown right off the deck of his ship in high winds. The table on page 40 indicates the wind effect on creatures. It presents the same information as Table 3-24: Wind Effects in Chapter 3: Adventures from the DMG, though it is rearranged for easier reference. Creatures receive a Fort save to avoid being affected by the wind, but the save must be rolled each round the wind blows. Checked creatures are unable to move forward against the force of wind, and flying creatures are blown back 1d6x5 feet. Knocked down creatures are knocked prone by the force wind, and flying creatures are instead blown back 1d6x10 feet. Blown away creatures on the ground are knocked prone and rolled 1d4x10 feet, taking 1d4 nonlethal damage per 10 feet, or if flying are blown back 2d6x10 feet and take 2d6 nonlethal damage due to battering and buffeting.

## Aerial Distance Table

This table tells you the straight-line distance between two creatures at different elevations, rounded to the nearest five foot increment. Find the vertical distance along the left side and cross-reference the horizontal distance along the top. The result is the distance between the creatures, traveling in the most direct route. (For you math wonks, this is the Pythagorean calculation of the hypotenuse, rounded to the nearest 5.) For example, a flying creature with a medium load has a speed of 40 feet (and thus a charging speed of 80 ft.). He is flying 70 feet above a sky ship. He wants to charge a sailor on the sky ship's deck below him, but the sailor is 50 feet to the east of the creature's horizontal position. Cross-referencing a vertical distance of 70 feet with a horizontal distance of 50 feet, we find that the straight-line distance between them is 85 feet – just outside the creature's charging range.

Vertical Distance	Horizontal Distance																			
	5	10	15	20	25	30	35	40	45	50	55	60	65	70	75	80	85	90	95	100
5	5	10	15	20	25	30	35	40	45	50	55	60	65	70	75	80	85	90	95	100
10	10	15	15	20	25	30	35	40	45	50	55	60	65	70	75	80	85	90	95	100
15	15	15	20	25	30	30	35	40	45	50	55	60	65	70	75	80	85	90	95	100
20	20	20	25	25	30	35	35	45	50	55	60	65	70	75	80	85	90	95	100	
25	25	25	30	30	35	40	40	45	50	55	60	65	70	75	80	85	90	90	95	100
30	30	30	35	35	40	40	45	50	55	55	60	65	70	75	80	85	90	95	100	105
35	35	35	40	40	45	45	50	50	55	60	65	70	75	75	80	85	90	95	100	105
40	40	40	40	45	45	50	50	55	60	65	65	70	75	80	85	90	95	95	100	105
45	45	45	45	50	50	55	55	60	65	65	70	75	80	80	85	90	95	100	105	110
50	50	50	50	55	55	55	60	60	65	70	75	75	80	85	90	95	100	100	105	110
55	55	55	55	60	60	60	65	65	70	75	75	80	85	90	90	95	100	105	110	115
60	60	60	60	60	65	65	70	70	75	75	80	85	85	90	95	100	105	105	110	115
65	65	65	65	70	70	70	75	75	80	80	85	85	90	95	100	100	105	110	115	120
70	70	70	70	70	75	75	75	80	80	85	90	90	95	100	100	105	110	115	115	120
75	75	75	75	75	80	80	80	85	85	90	90	95	100	100	105	110	110	115	120	125
80	80	80	80	80	85	85	85	90	90	95	95	100	100	105	110	110	115	120	125	125
85	85	85	85	85	90	90	90	90	95	95	100	100	105	105	110	110	115	120	125	130
90	90	90	90	90	90	95	95	100	100	105	105	110	110	115	115	120	125	125	130	135
95	95	95	95	95	95	100	100	105	105	110	110	115	115	120	120	125	125	130	135	135
100	100	100	100	100	100	100	105	105	110	110	115	115	120	120	125	125	130	135	135	140
100	100	100	100	100	105	105	105	105	110	110	115	115	120	120	125	130	130	135	140	140
105	105	105	105	105	110	110	110	110	115	115	120	120	125	125	130	130	135	140	140	145
110	110	110	110	110	115	115	115	120	120	120	125	125	130	130	135	135	140	140	145	150
115	115	115	115	115	120	120	120	120	125	125	130	130	130	135	140	140	145	145	150	150
120	120	120	120	120	125	125	125	125	130	130	130	135	135	140	140	145	150	150	155	155
125	125	125	125	130	130	130	130	135	135	140	140	140	140	145	145	150	150	155	160	160
130	130	130	130	130	130	135	135	135	140	140	140	140	145	145	150	150	155	155	160	165
135	135	135	135	135	140	140	140	140	140	145	145	150	150	150	155	160	160	160	165	170
140	140	140	140	140	140	145	145	145	145	150	150	150	155	155	160	160	165	165	170	170
145	145	145	145	145	145	150	150	150	150	155	155	155	160	160	165	165	170	170	175	175
150	150	150	150	150	150	155	155	155	155	160	160	160	165	165	170	170	170	175	180	180
155	155	155	155	155	155	160	160	160	160	165	165	165	170	170	170	175	175	180	180	185
160	160	160	160	160	160	165	165	165	165	170	170	170	175	175	180	180	185	185	190	195
165	165	165	165	165	165	170	170	170	170	170	175	175	175	180	180	185	185	190	190	195
170	170	170	170	170	170	175	175	175	175	175	180	180	180	185	185	190	190	190	195	195
175	175	175	175	175	175	180	180	180	180	180	185	185	185	190	190	190	195	195	200	200
180	180	180	180	180	180	180	185	185	185	185	190	190	190	195	195	195	200	200	205	205
185	185	185	185	185	185	185	190	190	190	190	195	195	195	200	200	200	205	205	210	210
190	190	190	190	190	190	190	195	195	195	195	200	200	200	205	205	205	210	210	210	215
195	195	195	195	195	195	195	200	200	200	200	205	205	205	205	210	210	210	215	215	220
200	200	200	200	200	200	200	205	205	205	205	205	210	210	210	215	215	215	220	220	225

## Wind Effects on Sky Ships

Wind Force	Wind Speed	Ranged Attacks Normal/Siege <sup>1</sup>	DC <sup>2</sup>	Wind Effect by Ship Size					
				Small	Medium	Large	Huge	Gargantuan	Colossal
Light	0-10	-/-	-	Safe	Safe	Safe	Safe	Safe	Safe
Moderate	11-20	-/-	-	Safe	Safe	Safe	Safe	Safe	Safe
Strong	21-30	-2/-	-	Safe	Safe	Safe	Safe	Safe	Safe
Severe	31-50	-4/-	10	Unsafe	Safe	Safe	Safe	Safe	Safe
Windstorm	51-74	Impossible/-4	15	Unsafe	Unsafe	Unsafe	Safe	Safe	Safe
Hurricane <sup>3</sup>	75-174	Impossible/-8	20	Dangerous	Dangerous	Dangerous	Unsafe	Safe	Safe
Tornado <sup>3</sup>	175-300	Imp./Imp.	30	Dangerous	Dangerous	Dangerous	Dangerous	Unsafe	Unsafe

## Wind Effects on Creatures

Wind Force	DC <sup>4</sup>	Wind Effect by Creature Size <sup>5</sup>						
		Tiny	Small	Medium	Large	Huge	Gargantuan	Colossal
Light	-	None	None	None	None	None	None	None
Moderate	-	None	None	None	None	None	None	None
Strong	10	Knocked down	None	None	None	None	None	None
Severe	15	Blown away	Knocked down	Checked	None	None	None	None
Windstorm	18	Blown away	Blown away	Knocked down	Checked	Checked	None	None
Hurricane <sup>3</sup>	20	Blown away	Blown away	Blown away	Knocked down	Checked	None	None
Tornado <sup>3</sup>	30	Blown away	Blown away	Blown away	Blown away	Knocked down	Checked	Checked

Wind speed is measured in mph.

<sup>1</sup> Apply this penalty to ranged attacks. The siege weapon category includes ballista and catapult attacks, as well as giant-tossed boulders. Note that dart launchers (see page 30) are considered normal ranged weapons, not siege weapons, for these purposes.

<sup>2</sup> The Profession (sky sailor) DC to avoid crashing for unsafe ships of clumsy or poor maneuverability, and all dangerous ships.

<sup>3</sup> Winds of this speed are generally not encountered above cloud level. If they were encountered, it would be an aberrant event worthy of investigation – perhaps caused by an angry air elemental, a cabal of aerial wizards, or some sort of unnatural vortex to the plane of air.

<sup>4</sup> The Fortitude save to avoid being subjected to the wind effects.

<sup>5</sup> Flying or airborne creatures are treated as one size category smaller than their actual size, so a human wizard with winged boots is treated as being size Small.

## Sky Ship Statistics by Size

	Small	Medium	Large	Huge	Gargantuan	Colossal
Hit Dice	1-2	3-8	9-25	26-40	41-60	61+
Hardness	1/2 material	As material	As material	As material	1.5x material	2x material
Base Speed	120 ft.	80 ft.	60 ft.	40 ft.	20 ft.	10 ft.
Base Maneuver	Perfect	Good	Average	Poor	Clumsy	None
Hard Points	None	1 ballista	2 ballistae, 1 catapult	4 ballistae, 2 catapults	8 ballistae, 4 catapults	16 ballistae, 8 catapults
Crew	1	12	48	100	200	350
Cargo	250 lbs.	1000 lbs.	5 tons	25 tons	100 tons	400 tons
Width	5 ft.	10 ft.	20 ft.	40 ft.	80 ft.	120 ft.
Length	10 ft.	30 ft.	60 ft.	120 ft.	240 ft.	360 ft.
Height	Top deck	2 decks	3 decks	4 decks	5 decks	6 decks





## Chapter Three

# Sky Ships

With the high level of magic found in many fantasy RPG campaigns, enchanted vehicles designed to soar through the air are not beyond the realm of possibility. After all, what use are cloud kingdoms, sky realms, and other areas high above the earth if adventurers have no means of traveling to them? Magic such as *fly* and similar spells are too limited to make travel simple for characters. Furthermore, without some form of reliable transportation the sky kingdoms would lack the ability to carry on any meaningful trade or migrations. Thus, sky ships represent the most common method for non-flying creatures to take to the air.

Sky ships were invented by the sky elves with the aid of their deity Laelus. When the elves first took to the sky, Laelus gave them five giant flying ships as a gift. After using them to find their homes in the sky, he bid the elves to disassemble the vessels in order to learn the secrets of their manufacture. Since then, the elves have mimicked Laelus's designs but have never duplicated them. Over the years, the secret of the sky ships' manufacture has spread to other races. Avians, arachnids, and even some human kingdoms now boast small fleets of these flying ships.

## In Your Campaign

Sky ships are an artifact of high fantasy worlds. If magic is common in your game (as represented by particularly powerful spells, archmages, and ancient artifacts), sky ships should fit into the general feel of the game. A few wizards know how to construct them and most commoners have seen one soaring across the sky at some point in their lives. In lower magic campaigns where powerful wizards are rare and magic is a wondrous rarity, sky ships are rarely encountered on the surface. The sky elves use and maintain them, but the cost and time needed to manufacture them reserves their use for only the most important tasks. Of course, cloud kingdoms and other aspects of an aerial realm fall firmly in the high fantasy camp. As discussed earlier, if you plan to use cloud realms in a low fantasy game you need to include some explanations as to why cloud kingdoms tend to have more magic than ground ones.

## Sky Ships: An Overview

Sky ships are treated much like a flying monster or other large creature in these rules. They have an armor class, hit points, speed, and maneuverability. Sky ships of a given size have the same general stats, as shown in the table on the facing page, though individual sky ships may vary from this standard profile. A sky ship is described by the following statistics:

**Armor Class:** As with player characters and monsters, a ship's armor class represents its level of protection against attacks. Since ships effectively have a Dexterity of 0, they automatically suffer a -5 penalty to AC. In addition, a ship's base size modifies its AC. Small ships gain a +1 size bonus to AC, Medium ones a +0 bonus, Large ones a -1 size penalty, Huge ones a -2 size penalty, Gargantuan ones a -4 size penalty, and Colossal ones a -8 size penalty. Add this specific size penalty to a sky ship's inherent -5 penalty to determine its final AC. For example, a normal Small ship is AC 6. It suffers a -5 penalty for being a ship but gains a +1 size bonus for being Small, for a total -4 penalty to AC.

A ship's AC may never be less than 1. However, if a ship gains the benefits of cover or some sort of protective magic add the full size penalty to its AC before adding any bonuses. For example, a Huge ship suffers a -5 AC modifier for being a ship a -8 size penalty to AC. Its AC is 1, even though its penalties add up to -13. However, a +3 AC bonus does not give it an AC of 4. The total penalties (-13) plus the bonus (+3) total to -10.

**Hit Dice:** Much like monsters and characters, ships have hit dice to represent how much punishment they can absorb before being destroyed. A ship's hit die type is always a d10 and it always gains 5.5 hit points per die. Round down any decimals when determining its final hit points. A ship's hit dice are determined by its size, as per the facing table.

**Hardness:** The material used to construct a ship determines how durable it is. A ship gains a hardness rating equal to the hardness of the material used to build it, with some modifiers. Small ships receive half their material's hardness, rounded down. Small ships have thinner hulls than other ship types. Gargantuan ships have a hardness equal to 1.5 times the material hardness while Colossal ones have a hardness equal to twice their material. These ships have extremely thick, durable hulls that absorb crushing blows with ease.

**Base Speed:** A ship's base speed is determined by its size. This speed may be increased by adding to the ship's total gold piece price (see *Designing Ships* on page 44). A ship flies 4.5 miles per hour for every 20 feet of its speed.

**Base Maneuver:** Just like flying creatures, ships are rated for their maneuverability in the air. A ship's base maneuver may be altered by increasing the ship's gold piece cost (see *Designing Ships* on page 44).

**Hard Points:** When outfitted for war, a ship can carry a certain number of weapons determined by its size. The hard points listing details the maximum number and type of weapons a ship may carry. Other weapons may be substituted for the standard catapult and ballista; see page 30.

**Crew:** A ship needs sailors to keep it flying smoothly. The crew listing details how many sailors a ship needs. A ship may carry a number of non-sailor passengers up to the size of its crew.

**Cargo:** Sky ships must carry their own supplies, and

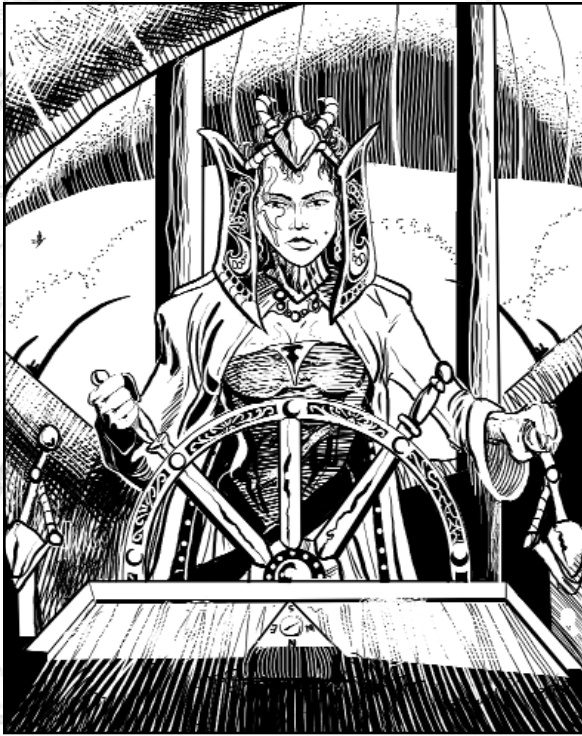

## Actions

On the captain's initiative, he may use the following actions to command the ship. At least half the crew must be alive and capable of carrying out commands to complete these actions. Otherwise, the ship either hovers in place or continues forward at its minimum forward movement rate.

Unless otherwise noted, the following guidelines use the aerial combat rules presented in this book.

**Movement:** As a move action, the captain may move the ship at up to its speed, using its maneuverability to determine how it may move and at what speed. Ships may "run" if they move straight ahead without making any turns. A ship may also take a double move, maneuvering as normal. Air ships are controlled by a turning wheel and two levers, one that controls its upward or downward angle and a second that determines its speed.

As a default, air ships use sails to supplement their speed when traveling long distances but rely primarily on magical power for propulsion in combat. Some rely more heavily on the wind, however, at least for part of their propulsion. If this is the case, a ship moves 50% faster when it moves with the wind at its back. The ship moves at its normal speed when it moves perpendicular to the wind and at half speed when it moves against it.

**Evasive Maneuvers:** If the captain uses a move action to move the ship, he may then use his standard action to attempt to evade enemy attacks. When the captain takes evasive maneuvers, the crew cannot attack as they execute his orders, but the ship gains an AC bonus based on its maneuverability:

Maneuver	AC Bonus
Perfect	+8
Good	+4
Average	+2
Poor	+1
Clumsy	+1

**Ramming Attack:** To make a ramming strike, the attacking ship must move into a space occupied by the target. The attacking ship's captain then makes an attack using his full base attack bonus modified by Dexterity against the target's AC. If a ship collides with a solid object at any point during its move, it immediately resolves a ramming attack against whatever it hit.

Damage from a ramming attack is determined by the size of the ramming ship. In addition, when a ship rams a target it also takes damage based on the size of the object it struck. The ship that was rammed takes damage based on the size of the attacking ship, and the attacker takes damage based on the size of the defender. The base damage by ship size is as follows, with the conditions below modifying the base amount.

Ship Size	Ram Damage
Small	2d8
Medium-size	4d8
Large	8d8
Huge	16d8
Gargantuan	32d8
Colossal	64d8

most haul goods between markets. A ship may carry cargo weighing up to the listed value in pounds or tons.

**Abilities:** While a ship's ability scores do not normally come into play, you may need to use them when adjudicating the effects of spells or other events. A ship's Strength and Constitution equal twice its hit dice. Use its captain's saving throws. See page 43 for more information on how a captain commands a ship and affects its handling.

## Sky Ship Combat

Travel through the aerial realm is a dangerous proposition. The creatures that dwell there are stronger, more vicious, and more predatory than ones commonly found on land. Combat between a sky ship and a marauding creature or pirate fleet is an almost inevitable eventuality.

In battle, one member of the crew must be designated as the captain. The ship moves on the captain's initiative, using his Dexterity modifier. In addition, when the ship must make a saving throw or skill check, use the captain's skills or saves.

**Attacks from Below:** Sky ships resemble sailing ships in general design. When attacked from below, they normally have little recourse in terms of weapons and counterattacks. However, some newer designs incorporate weapons turrets in their bellies.

**Combat Scale:** If you use miniatures and a combat map to keep track of battles, ships can pose a slight problem in terms of scale. They are generally large enough to take up the entire space represented by a map that uses 5 ft. squares. To counter this, consider scaling the map up so that each square on the mat is 20 ft. across. What you lose in fine detail you gain in usability. When ships close or a melee erupts, use a smaller map with a 5 ft. scale to represent the action or zoom in on one smaller section of the battlefield.

### Impact Condition

Defender, not moving away  
Defender, moving away from attacker  
Attacker, defender not moving away  
Attacker, defender moving away  
Attacker, head-on collision  
Per full 20 ft. of speed (either ship)

### Modifier

Full damage  
1/2 damage  
1/2 damage  
1/4 damage  
Full damage  
+1d8, max 2x

If the ships hit head on, the defending ship deals full rather than half damage. If the attacker and defender are both moving in the same direction and the attacker hits the defender from behind, the defender takes half normal ramming damage and the attacker takes a quarter of the ramming damage dealt by the defender rather than half.

A ship deals an additional 1d8 damage for every full 20 feet of its speed. However, a ship may never more than double the dice it uses for damage due to its speed. For example, a Small ship never deals more than 4d8 damage even if it moves at 60 feet when it hits its target. Regardless of how far the ship actually travels before hitting its target, the attacking captain selects his ship's current speed for purposes of determining ramming damage. However, the ramming ship's speed must always be fast enough to reach its target. For example, a pirate ship with a maximum speed of 50 feet is 30 feet away from its target. It may opt to move at a speed from 30 to 50 feet when making its ramming attack.

On a missed ram, the defender may opt for the attacker to move either above or below his ship.

On a successful ram, the attacking ship either smashes through its target or becomes caught on it. If the ram attack destroys the defender, the attacker moves straight forward at its normal speed. If the defender survives, the two ships are now tangled together.

Each round, each ship's captain may attempt to break free by making a successful Profession (sky sailor) check (DC 20). Otherwise, they remain stuck in place. If a ship has a minimum forward distance, the larger of the two continues to move forward at that speed, carrying the smaller ship with it. If both are the same size, the faster moving ship or the ramming ship moves and drags the other. If a ship breaks free, it may move as normal.

Unless the defender was moving away from the attacker, the attacker suffers an additional d8 damage for every 20 feet of the defender's speed. The defender may never deal more than double its base ramming damage due to speed. This damage is still halved, as normal (and otherwise modified as above).

**Attacks:** Most ships are outfitted with ballistae, catapults, and other weapons. Each weapon is assigned a firing arc, either rear or forward. Weapons may only fire into the ship's arc they are assigned to. The captain does not normally control a ship's weapon. Instead, the crew controls and fires them. As the crew takes casualties, the captain may assign sailors to one weapon or another to keep them fully manned.

When using catapults, one of those weapons per firing may opt to make a ranging attack. Based on the result of that attack, the other catapult crews may adjust their shots. To make a ranging attack, one catapult makes a normal attack against a target. However, if the strike hits the catapult deals no damage. Instead, it grants a +4 competence bonus to attack rolls for all other catapults that fire into its arc that target the same ship or monster it aimed for. On a miss, the cat-

apult grants no bonus or penalty to its allies. Only one catapult per arc per round may attempt this ranging attack.

## Destroying Ships

When a ship is reduced to 0 or fewer hit points, it immediately begins to break into pieces. Each round, it loses 1 additional hit point. At -10 hit points it crumples apart and is destroyed.

## Fire

Ships take fire damage as normal and may be set aflame. If a ship is set on fire, one crewman may use a full-round action to extinguish the flames in a 5 foot-by-5 foot area. If the flames continue to burn, there is a chance they spread. There is a 5% chance per burning 5-foot square area that the flames spread. Check against this percentage each round. If the flames do consume more of the ship, a number of 5-foot square areas equal to half the total area in flames, rounding up, also catches fire. These newly ignited areas must be adjacent to areas that were previously in flames. The ship takes 1d6 damage for each 5-foot square area that is on fire.

For example, a sky elf war wizard flies aboard a pirate sky ship and drops a vial of alchemist's fire upon it. This causes a single 5-foot square area to catch fire. The ship takes 1d6 damage each round that fire burns. Each round, there is a 5% chance that the flames spread to an additional 5-foot square area. If this happens, the ship now takes 2d6 damage per round from the flames and there is a 10% chance that the fire spreads.

Note that only spells and effects that are specified as igniting a target and causing additional damage from burning may set a ship on fire. Spells such as *fireball* do not set their targets on fire after dealing their damage.

## Ship's Crew

The captain may opt to either have his crew take an action immediately after his action or he may roll one initiative for the entire crew. The crew may attack, man the ship, operate shipboard weapons, and so forth. A number of sailors equal to at least half the minimum crew size must tend to the ship just to keep it moving. The rest may fight or operate the ship's weapons. Evasive maneuvers occupy the whole crew.

Sky ship crews can be broken down into three basic types: poor, average, and elite.

A poor crew is comprised of 90% 1st-level commoners and 10% 1st-level experts. All have the Profession (sky sailor) skill with the maximum ranks for their level. Each member of a poor quality crew expects 1 copper piece per day in wages.

An average crew is 50% 1st-level commoners, 40% 1st-level experts, and 10% 3rd-level experts. All have the maximum ranks allowable in Profession (sky sailor). Each member of an average quality crew expects 5 cp in wages per day.

An elite crew is 40% 1st-level experts, 30% 3rd-level experts, 20% 1st-level warriors, and 10% 6th-level experts.





All crewman max out their Profession (sky sailor) skills and most experts have the feat Skill Focus (Profession (sky sailor)). Each member of an elite crew expects 1 sp in wages per day. See page 112 for sailor stats.

## Spells and Ships

Ships count as inanimate for most spell effects. Not surprisingly, they are immune to mind-influencing effects, poison, disease, and similar effects. Nonlethal damage, ability damage, and energy drain have no effect on them. All other spells deal damage to them as normal. Generally speaking, spells can deal damage to ships but cannot alter their abilities, hinder them, or improve their performance.

## Repairing Ships

To repair a ship, calculate its cost per hit point by dividing its gp value by its maximum hit points. To repair the ship, you must make a Craft (woodworking) or Craft (shipbuilding) check. The gp value of your work is converted into the equivalent number of hit points to see how much you repair in a given day or week. Up to up to 4 repairmen may work on the ship each day for every 10 hit dice it has or fraction thereof.

## Designing Ships

To design a ship, follow these basic steps.

1. Choose a ship size and hit dice. A ship has 5.5 hit points per hit die, rounded down. A ship's base price factor equals its normal hit dice.
2. Determine the ship's speed and maneuverability. Look up the design's base speed and maneuverability on the tables on page 40. You may increase a ship's speed by 20 feet or improve its maneuverability by one class by adding its base price factor to its current price factor. A ship may not have a speed greater than 200 feet, nor may it improve its maneuverability by more than two categories.

For example, a 10 hit die ship has a base price factor of 10. For every 20-foot increase added to its base speed, increase its price factor by 10. For every maneuverability category it improves, its price factor increases by 10. Thus, a 10 HD ship with 40 added to its base speed has a price factor of 30 (its base price factor of 10 plus 10 for the first bonus 20 feet of speed and another 10 for the second 20 feet increase.)

You may opt to reduce a ship's base speed or its maneuverability class. For every 20-foot or one category reduction, reduce the ship's price factor by one-fifth of its base price factor. A ship may not reduce its price factor by more than half its base price factor in this manner.

3. Compute the ship's base price by multiplying its price factor by 800 gp.
4. Choose a building material. A ship may be made from metal or wood. Wooden ships cost the base price determined in step 3 and have a base hardness of 5. Metal ones cost four times the price computed in step 3 and have a base hardness of 10.
5. Add weapons. A ship may have a number of weapons listed under the hard points for its size. Up to half the maximum number of weapons of a given type (rounded up) may be mounted in a given arc. One weapon for every full ten hit dice the ship has may be mounted on the ship's belly, allowing it to respond to attacks from below. Add the total cost for the weapons to the ship's base price. Weapons cost their listed market price (see page 30).
6. Add a template, if applicable (see following page).
7. Design a ship layout. A sky ship must have the minimum dimensions listed for its size, and it may be no larger than the next highest size class. See pages 136-143 for sample ship layouts.

A character with the Sky Shipwright feat may design and build a sky ship. He uses the design rules listed here and pays 75% of the final price in material cost and labor. If he opts to direct the construction of an established design, such as one listed here or one the GM determines is common to the area, he pays only half the design's listed price in gp. A ship takes one full week to build for every 1000 gp or fraction thereof that it costs to construct.

# Ship Templates

Once you have tinkered with the basic stats for a ship or chosen one of the sample generic ships, you may then apply a template to it in order to customize the vessel to your campaign or make it distinct from other designs. The four templates presented here offer flying machines that differ in form, structure, or propulsion from the standard sky ship. This volume assumes that a sky ship looks a lot like a typical sailing ship, with a wooden hull, decks, masts, sails, and so on. The templates allow you to quickly and easily construct ships that radically depart from that norm.

The four templates are autogyro, a steampunk helicopter; the sky fortress, a floating battle station designed to subjugate the sky around it and the ground beneath it; the undead hulk, a ship constructed by necromancers from the skeletal remains of flying creatures; and the zeppelin, a great flying machine that relies on a balloon to hold it aloft. Each template lists the modifications it makes to each facet of a sky ship's statistics and lists special rules that apply to the ships it creates.

## Autogyro (Template)

An autogyro is a simple, primitive helicopter that relies on small, steam-driven rotor blades to keep it aloft. While more maneuverable than a normal sky ship, an autogyro is vulnerable to damage and liable to crash if subjected to combat. Autogyros rely on speed and maneuverability to survive in battle. Normally, these vessels are used as fighters, escorts, and scouts. They tend to be small and quick rather than slow and bulky.

When applying the autogyro template to a ship, the following changes apply to the base ship's attributes. Unless otherwise listed, use the base statistics as normal. Only ships of Medium size or smaller may become autogyros.

**Ship Type:** An air ship's type changes to autogyro. Thus, a Medium air ship becomes a Medium autogyro.

**Hit Dice:** Autogyros are smaller and more fragile than normal air ships. Cut the base ship's hit dice in half, rounding up, and recalculate its hit points.

**Armor Class:** Autogyros are much smaller and nimbler than typical air ships. They do not suffer the -5 AC penalty all ships normally suffer. In addition, while autogyros are small they are agile and sturdily built. Autogyros gain a +4 natural bonus to AC.

**Hardness:** Autogyros have normal hardness.

**Speed:** An autogyro's speed increases by 10 feet.

**Maneuver:** Nimble for their size, an autogyro's maneuverability increases by one class over its base ship. If the base ship already has perfect maneuverability, the autogyro gains an additional +10 bonus to its speed. In addition, regardless of its maneuverability an autogyro always has the ability to hover and does not have a minimum speed.

**Crew:** An autogyro requires only half the crew of a standard air ship of the same size, rounded up.

**Dimensions:** Small autogyros are 10 feet long and 5 feet wide. Medium size ones are 20 feet long and 10 feet wide. Both have only one deck.

**Cargo:** An autogyro is faster than a normal ship but has much less space to carry equipment. Halve the base ship's

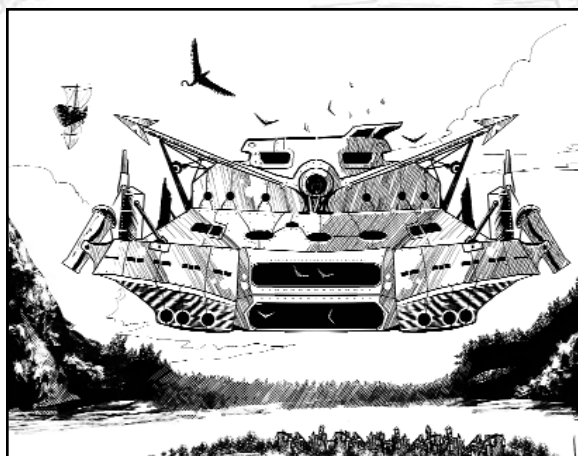

cargo capacity.

**Weapons:** Small autogyros may not carry artillery such as ballista and catapults. Medium size ones may mount a single ballista.

**Market Price:** The small, swift autogyros cost the same as a standard air ship. While they require expert craftsmanship to produce, the typical air ship requires magical resources that make the two equal in price.

## Sky Fortress (Template)

A sky fortress is a powerful battle station crafted to establish military dominance in a section of airspace or over a stretch of ground. Powerful overlords with access to mighty magics often craft these war machines to serve as mobile strong points. Nothing inspires more terror in an enemy army than the sight of a floating sky fortress disgorging flights of harpies, manticores, and other creatures to swoop from the sky and rain destruction upon the earth below.

"Sky fortress" is a template that may be added to a Large or bigger sky ship. A sky fortress uses the base ship's game statistics as normal except as noted below.

**Ship Type:** The sky ship's type changes to sky fortress.

**Hit Dice:** A sky fortress has the same hit dice as its base ship. However, its superior building materials and reinforced structure give it 10 hit points per hit die rather than 5.5. Recalculate the fortress's hit points accordingly.

**Armor Class:** Sky fortresses are roughly the same size as a sky ship. However, their size penalty to AC increases by 2. Sky fortresses tend to be built in a square rather than rectangular shape, making them easier targets.

**Hardness:** While sky ships are crafted from wood, sky fortresses are invariably built from stone and other heavy, fortified materials. A sky fortress's hardness becomes 10.

**Speed:** Sky fortresses are incredibly slow and ponderous. They move at half the base ship's movement rate.

**Maneuver:** While built for war, sky fortresses rely more on the strength of the soldiers stationed upon them and the fortitude of their reinforced walls. A sky fortress has a maneuverability rating two categories worse than its base ship, to a minimum of clumsy. However, all sky fortresses may hover in place.

**Crew:** In addition to the listed crew, who are required to maintain and man the ship, a sky fortress can hold twice its base ship's crew in marines, soldiers, and passengers.



**Dimensions:** A sky fortress has a basic, square arrangement. Each side is as long as the base ship's longest side. In addition, rather than decks it has floors.

**Cargo:** A sky fortress may carry three times the base ship's cargo.

**Weapons:** Sky fortresses are generally designed with portals, windows, arrow slits, and other features that make it much more suited for battle than its base ship. A sky fortress may carry 10 times the number of weapons listed for its base ship.

**Market Price:** Constructing a sky fortress requires far more magic, material, and other resources than a standard sky ship. Multiply the sky ship's gold piece cost by 5 to determine the sky fortress's total cost.

## Undead Hulk (Template)

Crafted from a grotesque collection of bones, flesh, sinew, and muscle, the undead hulk is a necromancer's preferred sky chariot. Many of these vehicles are built from the assembled skeletons of great birds of prey, dragons, and other flying creatures. Others are built wholly from scratch, with an enterprising necromancer carving or molding bones to fit his gruesome purposes. In battle, the undead hulk absorbs a tremendous amount of punishment. Worse still, it is imbued with necromantic energy that boosts the strength of undead it carries and enhances a necromancer or death cleric's magic.

"Undead hulk" is a template that may be added to any sky ship. The ship uses its base type's game statistics except as noted below.

**Ship Type:** The base ship's type becomes undead hulk. The ship counts as an undead creature for purposes of turning and other effects that injure undead or apply to them.

**Hit Dice:** The undead hulk retains its base ship's hit dice, though it now receives d12s rather than d10s for hit points. Thus, the hulk gains 6.5 hit points per hit die rather than 5.5.

**Armor Class:** The undead hulk gains a +6 natural bonus to AC. Much of its hull is dead flesh, old bones, and other debris that absorbs or deflects blows that would nor-

mally damage a ship.

**Hardness:** The undead hulk loses its hardness rating. The ship is built from bone and sinew. While it is still capable of absorbing tremendous amounts of damage, its structural material lacks the durability of wood, stone, and other building materials.

**Speed:** Undead hulks soar through the air with supernatural ease. The ship's affinity with necromantic magic grants it a +20 bonus to speed.

**Maneuver:** The hulk's magical nature allows it to turn with more precision than a similarly sized ship designed with the same propulsion and maneuvering options. Increase the base ship's maneuverability rating by one rank, to a maximum of perfect.

**Crew:** An undead hulk requires no crew. It automatically obeys the mental commands of whoever stands at its helm. The ship loads and fires its artillery, maintains its sails, and steers itself without the aid of crewmen. As an undead construct, the ship functions on its own.

**Dimensions:** The undead hulk has dimensions and a number of decks equal to its base ship.

**Cargo:** Undead hulks may carry cargo as per their base ship. They still require crew to load and unload cargo.

**Weapons:** As hulks are the same size and dimensions as the base ship, they may carry the same spread of weapons. However, undead ships have artillery built into their hulls with the same bone, sinew, and flesh as the rest of the ship. Thus, the undead hulk may control and operate its own weaponry. It does not need crewmen to load and fire these weapons.

**Market Price:** Due to their magical nature, undead hulks cost 1.5 times their base ship's price. A necromancer or cleric with access to the Death domain may build an undead hulk by spending half this listed price in materials and components. It takes a spellcaster 1 day per 1000 gp value of the ship to build it. A cleric must be 11th level while a necromancer must be 13th level to build a hulk. Both types of caster must have the Craft Wondrous Item feat in order to construct an undead hulk.

**Special Traits:** In addition to the abilities listed above, an undead hulk provides several benefits to undead who ride upon it and the spellcaster who crafted it.

**Aura of Death (Su):** The deck areas of the undead hulk are bathed in profane, necromantic energy. All undead aboard the ship gain +2 turn resistance. In addition, the entire ship counts as if it was under the effects of a *desecration* spell cast by a 15th-level cleric.

**Necromantic Affinity (Su):** The captain of the undead hulk stands at a nexus of its foul magic when he controls its helm. While commanding this ship, the captain gains a +1 caster level bonus when using any spell from the necromancy school.

**Necromantic Defenses (Su):** As an undead construct, the hulk is capable of repelling boarders and other attackers with its own abilities. Each round while aboard the ship, the hulk's enemies suffer a single claw attack at a +1 base attack bonus that deals 1d4 damage. The ship's bones swing wildly at intruders, hoping to batter them into unconsciousness. The ship must detect intruders before it can attack them. Resolve



these attacks immediately after an intruder takes his actions for a round.

**Sentient Craft (Su):** Once per minute, the undead hulk inspects itself to see if intruders, robbers, or other undesirables are aboard. To simulate this, the ship has 5 ranks in both Spot and Listen and a +0 Wisdom modifier. It may test both of those skills against any intruders aboard the ship. If it detects them, it attacks them using its necromantic defenses or alerts its crew by clattering its bones together or sounding a mournful dirge.

## Zeppelin (Template)

Held aloft in the air by a great, gas-filled balloon, the zeppelin mixes simple mechanics, engineering, and magic to produce a durable, efficient sky ship. While a zeppelin's balloon may seem to be a tremendous Achilles heel, in truth the balloon is designed specifically to absorb damage in battle. Rather than use one gigantic balloon, the zeppelin uses a series of small, independent gas cells to hold it aloft. Thus, a single attack may destroy a few cells but it leaves the whole of the balloon relatively intact. Only a truly powerful spell or monstrous creature could bring down a zeppelin in one strike.

Zeppelins are produced by gnome and dwarf inventors. In some regions, these vehicles ferry goods from high mountain peaks down to neighboring human towns and kingdoms. The zeppelin uses little magic in its construction, as its inventors rely on their basic knowledge of engineering to produce a relatively mundane flying machine.

"Zeppelin" is a template that may be added to any flying ship. It uses the base ship's game attributes as normal except as noted below.

**Ship Type:** The air ship's type changes to zeppelin.

**Hit Dice:** Zeppelins are broken down into two main parts, the balloon and the main decks, for purposes of hit points, hit dice, armor class, and other combat statistics. The deck area has the same hit dice and hit points as the base ship. The balloon is described below.

**Armor Class:** The zeppelin's main decks have the same AC as the base ship. The balloon's AC is detailed below under special traits.

**Hardness:** Zeppelins are invariably crafted from iron and steel. The main decks' hardness becomes 10 regardless of the base ship's value. Even small zeppelins gain this increased hardness.

**Speed:** Zeppelins tend to be much slower than their counterparts. Reduce the base ship's speed by 40 feet to determine the zeppelin's normal speed.

**Maneuver:** While zeppelins are slower than most other ships, they are far more maneuverable. Their great balloons allow them to float in place and make quick, precise turns. A zeppelin has a maneuverability class two ranks better than its base ship.

**Crew:** Zeppelins have a crew equal to half the base ship's standard crew. The compartments aboard a zeppelin are small and cramped, as its balloon is not as efficient as an air ship's magical hull with respect to lifting and propelling weight.



**Dimensions:** The base ship's dimensions describe the zeppelin's length and width. However, zeppelin cabins tend to be much smaller than normal ships. Halve each of the base ship's dimensions to determine the deck area's total size.

**Cargo:** A zeppelin can carry only half the base ship's listed cargo. As mentioned above, a zeppelin is much nimbler than a normal ship but is not well suited to hauling large amounts of goods.

**Weapons:** Zeppelins may carry twice the base ship's listed number of weapons. These vessels commonly mount weapons on multiple decks, not simply the top one, and include weapons mounted on the bottom hull.

**Market Price:** A zeppelin costs 1.25 times the base ship's market price. The esoteric nature of the engineering knowledge needed to construct these vessels makes them both rare and expensive.

**Special Traits:** Zeppelins have two special traits that separate them from other ships.

**Balloon Propulsion (Ex):** The great balloon that holds a zeppelin aloft is extremely durable. In combat, an attacker may choose to target the zeppelin's main decks or the balloon. The zeppelin's size determines its balloon's AC and hit points. Larger balloons are filled with hundreds, if not thousands, of individual air cells. Thus, the balloon is capable of absorbing tremendous amounts of punishment before it is ruptured and destroyed. For this reason, zeppelins are popular with dwarves and other races that may have to run a gauntlet of giants, dragons, and other fierce creatures to carry their cargo safely to its destination.

Size	AC	Hit Points
Small	8	50
Medium	7	100
Large	6	200
Huge	5	300
Gargantuan	3	500
Colossal	1	800

**Nimble Flier (Ex):** The zeppelin's agility in the air allows it to dodge attacks with ease. When targeted by an effect that allows a Reflex save, the zeppelin gains a +2 competence bonus to its result.

## Sample Sky Ship Statistics

Ships are listed from least expensive to most expensive.

Sky Ship	Price (gp)	Size	HD	HP	AC	Hardness	Speed	Maneuver	Crew	Size/Decks	Cargo	Weapons <sup>1</sup>
Stinger Autogyro	580	Small	1	5	15	2	80 ft.	Perfect	1	5x10/1	250 lbs.	2 crossbows
Lifeboat	800	Small	2	11	6	2	60 ft.	Perfect	1	5x10/1	250 lbs.	—
Basic Small	6,400	Small	2	11	6	2	180 ft.	Perfect	1	5x10/1	250 lbs.	—
Ice Frigate	8,000	Large	10	55	4	5	60 ft.	Average	48	20x60/3	5 tons	—
Basic Medium	9,600	Medium	6	33	5	5	100 ft.	Good	12	10x30/2	1000 lbs.	—
Basic Large	15,950	Large	18	99	4	5	60 ft.	Average	48	20x60/3	5 tons	Ballista x2 Light catapult
Undead Horde	24,000	Medium	10	65	11	0	120 ft.	Perfect	0	10x30/2	1000 lbs.	Ballista, ram
Spinner	26,100	Medium	8	44	5	5	120 ft.	Perfect	12	10x30/2	1000 lbs.	Ballista, ram
Orc Junkheap	33,100	Huge	40	220	3	5	40 ft.	Poor	100	40x120/4	25 tons	Light catapult x2
Javelin	46,600	Large	20	110	4	5	100 ft.	Poor	48	20x60/3	5 tons	Ballista x2 Hvy. catapult
Airhawk	51,200	Large	16	88	4	5	100 ft.	Good	40	20x60/2	5 tons	Ballista x2
Basic Huge	54,300	Huge	32	172	3	5	60 ft.	Poor	100	40x120/4	25 tons	Ballista x4 Light x3
Basic Gargantuan	86,200	Gargantuan	50	275	1	5	40 ft.	Clumsy	200	80x240/5	1000 lbs.	Ballista x8 Light catapult x4
Elf Skyrunner	130,000	Huge	32	176	3	5	80 ft.	Good	100	40x120/4	25 tons	Ballista x4
Basic Colossal	193,400	Colossal	75	412	1	5	30 ft.	Clumsy	350	120x360/6	400 tons	Ballista x16 Light catapult x4 Hvy. catapult x4
Warhawk	247,200	Gargantuan	50	275	1	5	80 ft.	Average	200	80x240/5	100 tons	Ballista x8 Hvy. catapult x4
Overlord Zeppelin	408,850	Colossal	75	412	1	10	30 ft.	Average	175	60x180/6	200 tons	Ballista x32 Light catapult x6 Hvy. catapult x10
Halfing Villageship	894,600	Colossal	75	900	1	10	15 ft.	Clumsy	350	360x360/6	1200 tons	Ballista x24 Light catapult x12

<sup>1</sup> All ships also have a ram attack.

## Sample Ship Designs

The following sky ships are all commonly found flying the air lanes. The entries for “basic” ships of each size are standard aerial vessels designed to serve as traders, explorers, and other general purpose ships. If you need a generic warship or trader, you can simply select one of these stat blocks to represent it. The other ships meant to represent the strange, bizarre, and specialized ships that soar through the skies. Deck plans for common ships are on pages 136-143.

### Airhawk

The sleek, deadly Airhawk is designed for swift strikes against slower or stationary targets. From a distance, this ship appears to be a great bird of prey. Its wooden foredeck is carved to resemble a screaming eagle, while majestic, wooden wings swoop from its sides and serve as foci for the elemental energies that keep it aloft. In battle, marines aboard the Airhawk climb down to the wings' edges. When the Airhawk passes an enemy ship, they leap aboard to overpower its crew and claim its cargo as their own. Needless to say, Airhawks are quite popular with pirates and other marauders. However, these ships are often used by more legitimate navies during times of war as scouts, pursuit ships, and patrol vessels.

**Airhawk:** Large Sky Ship; HD 16; hp 88; AC 4 (ship -5, size -1); Hardness 5; Speed 100 ft.; Maneuver Good; Crew 40; Dimensions 20 ft. by 60 ft., 2 decks; Cargo 5 tons; Weapons 2 ballistae, ramming attack (8d8 damage); Market price 51,200 gp.

**Special:** The Airhawk is designed to quickly insert marines onto enemy ships. When an Airhawk moves adjacent to an enemy ship, any marines standing on the edges of its wings may leap aboard the enemy ship with a move action, provided the Airhawk's captain pitches the ship slightly to allow the troops an easy leap. Soldiers attempting this maneuver must succeed at Jump checks to clear the space between the Airhawk and the enemy ship. Marines preparing to board in this manner may hold their action to make their Jump checks at any point during the Airhawk's movement.

### Arachial Spinner

The favored ship of the foul arachial raiders, the Spinner is a small, sleek vessel that looks something like a winged spider built from wood and metal. The Spinner's “legs” serve as landing gear, and the arachial commonly use it to land aboard larger ships to launch boarding actions.

**Spinner:** Medium Sky Ship; HD 8; hp 44; AC 5 (ship -5); Hardness 5; Speed 120 ft.; Maneuver Perfect; Crew 12; Dimensions 10 ft. by 30 ft., 2 decks; Cargo 1000 lbs.; Weapons ballista (forward arc), ramming attack (4d8 damage); Market price 26,100 gp.

### Basic Small Ship

Designed as a small transport, life raft, or landing craft, this ship only rarely sees extended use without the support of a harbor or a larger ship. The biggest ships in the sky lanes carry a few of these boats to ferry goods to land or to carry

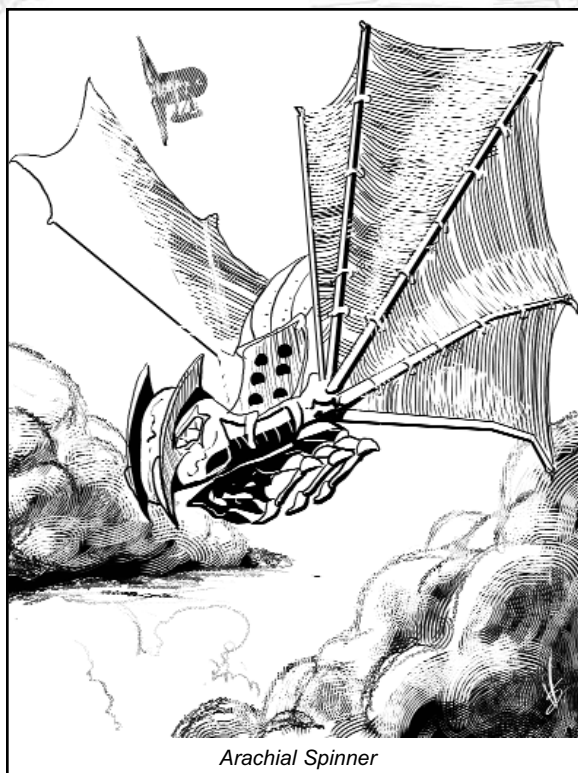

Arachial Spinner

boarding parties to enemy ships.

**Basic Small Ship:** Small Sky Ship; HD 2; hp 11; AC 6 (ship -5, size +1); Hardness 2; Speed 180 ft.; Maneuver Perfect; Crew 1; Dimensions 5 ft. by 10 ft., 1 deck; Cargo 250 pounds; Weapons ramming attack (2d8 damage); Market price 6,400 gp.

### Basic Medium Ship

The workhorse of the sky, ships in this size class serve as small-time merchants, explorers, and travelers. In regions where hunting and gathering are common, crews use these ships to scout out new regions and harvest plants and animals they find there.

**Basic Medium Ship:** Medium Sky Ship; HD 6; hp 33; AC 5 (ship -5); Hardness 5; Speed 100 ft.; Maneuver Good; Crew 12; Dimensions 10 ft. by 30 ft., 2 decks; Cargo 1000 pounds; Weapons ramming attack (4d8 damage); Market price 9,600 gp.

### Basic Large Ship

A common transport for merchants and a popular model with pirates and other raiders, the basic Large ship has size enough to carry significant weapons, cargo, and crewmen, but not so large that it is too expensive for the average trader (or buccaneer) to build and maintain.

**Basic Large Ship:** Large Sky Ship; HD 18; hp 99; AC 4 (ship -5, size -1); Hardness 5; Speed 60 ft.; Maneuver Average; Crew 48; Dimensions 20 ft. by 60 ft., 3 decks; Cargo 5 tons; Weapons 2 ballistae, 1 light catapult, ramming attack (8d8 damage); Market price 15,950 gp.

### Basic Huge Ship

Common only in the largest ports or in lands where the



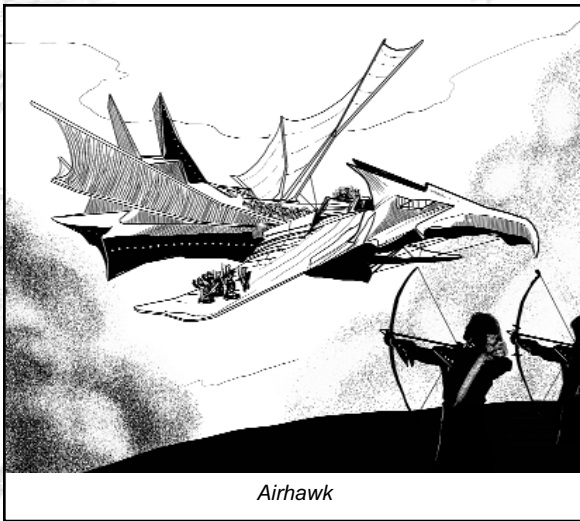

Airhawk

art of crafting flying ships is quite advanced, Huge flying ships serve as ships of the line in aerial navies, troop transports, and heavily armed merchant marines. Most air pirates prefer to steer clear of these ships, though their great cargoes prove too tempting for some brigands. After all, anyone rich enough to afford one of these ships either carries a lot of wealth or is worth a tremendous ransom.

**Basic Huge Ship:** Huge Sky Ship; HD 32; hp 172; AC 3 (ship -5, size -2); Hardness 5; Speed 60 ft.; Maneuver Poor; Crew 100; Dimensions 40 ft. by 120 ft., 4 decks; Cargo 25 tons; Weapons 4 ballistae, 2 light catapults, ramming attack (16d8 damage); Market price 54,300 gp.

### Basic Gargantuan Ship

In most aerial navies or shipping fleets, a Gargantuan ship is mighty enough to serve as a flagship or king of the fleet. These monsters serve more as flying fortresses than ships, as their large number of weapons and hundreds of crewmen can repel all but the most dangerous or dedicated opponents. Few governments, trading houses, or guilds can support more than one or two of these ships. In some areas, these vessels serve as floating way stations and strongholds.

**Basic Gargantuan Ship:** Gargantuan Sky Ship; HD 50; hp 275; AC 1 (ship -5, size -4); Hardness 5; Speed 40 ft.; Maneuver Clumsy; Crew 200; Dimensions 80 ft. by 240 ft., 5 decks; Cargo 100 tons; Weapons 8 ballistae, 4 light catapults, ramming attack (32d8 damage); Market price 86,200 gp.

### Basic Colossal Ship

Most air mariners can spend their entire lives in the skies and never see the awe-inspiring sight of one of these monstrous galleons floating through the air. Generally built as a one-of-a-kind model, a Colossal sky ship is the undisputed king of the airways. Even a dragon would have second thoughts about tangling with one of these vessels. Its hundreds of crewmen and artillery, and the wizards and clerics who serve aboard it, can bring tremendous firepower to bear on any target. Colossal ships are invariably built for war. Slow and ponderous, they advance on the enemy as a relentless, indomitable juggernaut.

**Basic Colossal Ship:** Colossal Sky Ship; HD 75;

hp 412; AC 1 (ship -5, size -8); Hardness 5; Speed 30 ft.; Maneuver Clumsy; Crew 350; Dimensions 120 ft. by 360 ft., 6 decks; Cargo 400 tons; Weapons 16 ballistae, 4 light catapults, 4 heavy catapults, ramming attack (64d8 damage); Market price 193,400 gp.

### Elf Skyrunner

While the surface elves rarely seek to journey to the sky, their highly developed magical talents and affinity for crafting items made from wood and other natural materials make them well suited to building sky ships. The elves as a whole have little interest in leaving their forest realms, but a few archmages and other powerful spellcasters amongst them sometimes feel the need to journey to the cloud realms. These explorers seek magical knowledge, lost artifacts, and other treasures the aerial realms or other distant places may hold.

The Elf Skyrunner is a unique ship. Unlike most vessels, it is not built from scratch. Rather, the Skyrunner is carefully grown from the living wood of the elves' forests. The mage or shipwright who wishes to craft a Skyrunner selects a single gigantic tree. Using a series of magical incantations, he slowly convinces the spirit that dwells within the tree to mold itself into the form of a sky ship. This process can take years to complete, but the results are well worth it. The Skyrunner is a living plant creature that lives, breathes, and grows long after it is commissioned into service. As such, it can rapidly heal damage sustained in battle and can even re-grow itself from its component parts after it is destroyed in battle. Needless to say, these ships are highly prized by the wizards and druids who spend the many decades necessary to construct them.

**Elf Skyrunner:** Huge Sky Ship; HD 32; hp 176; AC 3 (ship -5, size -2); Hardness 5; Speed 80 ft.; Maneuver Good; Crew 100; Dimensions 40 ft. by 120 ft., 4 decks; Cargo 25 tons; Weapons 4 ballistae, ramming attack (16d8 damage); Market price 130,000 gp.

**Special:** The Skyrunner regenerates 5 hit points of damage each round. Only acid damage ignores this regeneration. In addition, as a living plant creature the Skyrunner has sap, water, and other fluids running through its decks and planks. Thus, it takes only half damage from all fire attacks, spells, and other effects. While most plants are vulnerable to fire, the Skyrunner is specially designed to retain as much water as possible in order to allow it to shrug off damage from flames.

### Ice Frigate

Ice frigates get their name from their original use, which was hauling huge chunks of ice from mountaintops. Cloud cities often lack large sources of fresh water, so they survived on nearby icecaps. Because of limited storage area on the cloud settlements, the ice frigates were built for many regular trips rather than one infrequent haul. Over time this smaller size of transport ship was adapted for many other uses, and became particularly popular among independent miners and prospectors, who often strip off the weapons to maximize carrying capacity. Teams of skaedrim sometimes use ice frigates.

**Ice Frigate:** Large Sky Ship; HD 10; hp 55; AC 4 (ship -5, size -1); Hardness 5; Speed 60 feet; Maneuver Average; Crew 48; Dimensions 20 ft. by 60



Halfling Villageship

ft., 3 decks; Cargo 5 tons; Weapons ramming attack (8d8 damage); Market Price 8,000 gp.

### Halfling Villageship

The nomadic halflings endlessly wander the world, using their wits, cunning, and stealthy natures to eke out an existence amongst the taller, stronger humans, elves, orcs, and other humanoid races. Some halfling clans count a powerful wizard amongst them who, through long toil and clever planning, constructs a giant, flying vessel capable of carrying the entire clan from place to place. These villageships are incredibly rare. Few halflings master the arcane arts, and those who do rarely have the resources, time, or inclination to construct a project as ambitious and expensive as a villageship.

A villageship is designed in a roughly circular shape. A 10 foot high outer wall serves more to prevent the halflings and their possessions from tumbling overboard rather than to repel intruders in the air. On the ground, the wall serves its normal purpose as a defensive stockade. A gate built within it allows for easy access to and from the ship. Three towers set into the wall house guards, while a taller central tower serves as a lookout point. The ship's upper deck literally hosts a small halfling village, with several houses, huts, workshops, and stores built on to it. Lower decks host more living space, storage areas, and meeting rooms.

Villageships are essentially small, mobile communities. The halflings land near a friendly town or village and open their gates to accept visitors, merchants, and buyers interested in their wares. To drum up business, the halflings typically host a small carnival or festival within their village shortly after landing. Games of chance, merchants booths, and a small entrance fee help fund the village and allow it to stock up on food and water.

In battle, villageships rely on their great size and numbers to repel attackers. As these vessels are slow and ponderous, the halflings must rely on their expert skill with ranged weapons to drive away attacking wyverns, griffons, and other monsters.

**Halfling Villageship:** Colossal Sky Fortress; HD 75; hp 900; AC 1 (ship -5, size -10); Hardness 10; Speed 15 ft.; Maneuver Clumsy; Crew 350; Dimensions 360 ft. by 360 ft., 6 decks; Cargo 1200

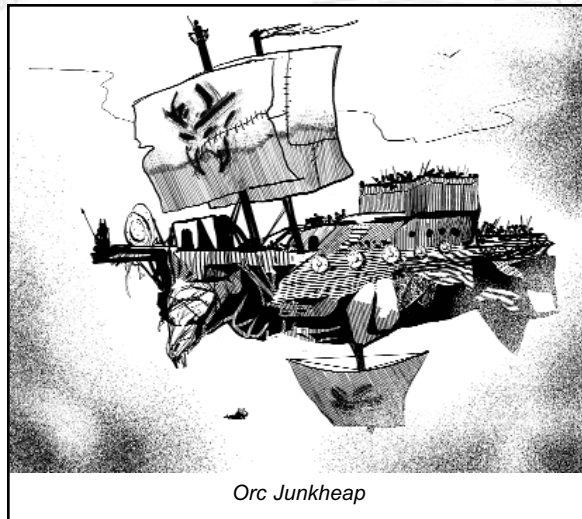

Orc Junkheap

tons; Weapons 24 ballistae, 12 light catapults, ramming attack (64d8 damage); Market price 894,600 gp.

*Special:* Villageships generally have one or more of the following hosted within a small shop: a blacksmith, trader, bakery, weaponsmith, or general store.

### Javelin

A fast but unwieldy ship, the Javelin is commonly used by independent captains, privateers, and pirates. They are cheap, easy to maintain, and commonly sold in isolated ports beyond the reach of the sky elf navy.

**Javelin:** Large Sky Ship; HD 20; hp 110; AC 4 (ship -5, size -1); Hardness 5; Speed 100 ft.; Maneuver Poor; Crew 48; Dimensions 20 ft. by 60 ft., 3 decks; Cargo 5 tons; Weapons ballista (forward arc), ballista (rear arc), heavy catapult (forward arc), ramming attack (8d8 damage); Market price 46,600 gp.

### Lifeboat

The captain may want to go down with the ship, but the crew rarely earns enough cash to agree to such terms of employment. Most larger ships and those that commonly stray far from friendly ports or into dangerous territory carry a small number of lifeboats.

**Lifeboat:** Small Sky Ship; HD 2; hp 11, AC 6 (ship -5, size +1); Hardness 2; Speed 60 ft.; Maneuver Perfect; Crew 1; Dimensions 5 ft. by 10 ft., 1 deck; Cargo 250 pounds; Weapons ramming attack (2d8 damage); Market price 800 gp.

### Orc Junkheap

While most sages and explorers would consider the savage orcs too primitive and impatient to construct vessels capable of taking to the sky, in truth the orcs can construct sky ships when driven by a pressing need or a suitably vicious and driven warlord. Orc ships are known as Junkheaps. From a distance, they look like little more than piles of wooden planks, iron beams, and rough tarpaulin pulled together in the vague shape of a flying ship. Closer inspection merely reinforces this initial impression. The orcs are poor craftsmen, as they lack the patience and wits to build anything of beauty. Instead, they pile up wood and

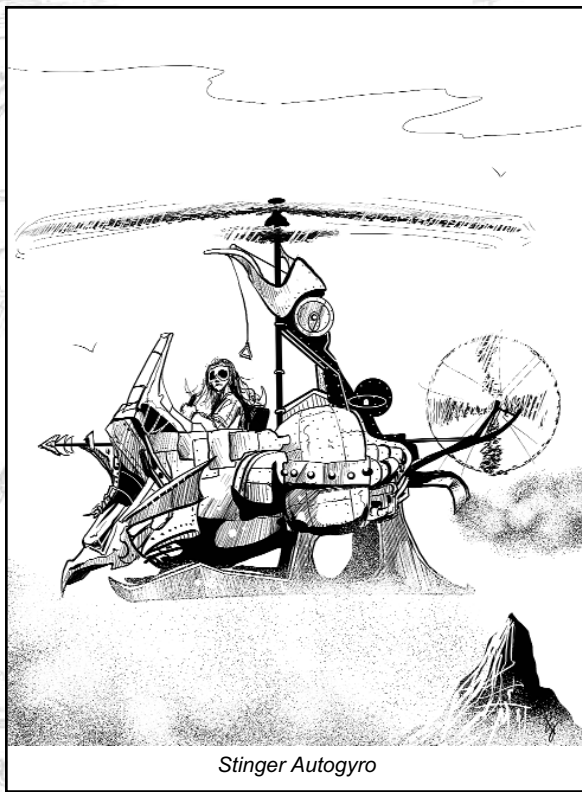

Stinger Autogyro

other building materials they scrounge into the vague form of a ship. Their shamans and sorcerers then imbue the hulking pile of wood and metal with the magic necessary to send it aloft. While orc ships are slow and difficult to handle, they are incredibly difficult to destroy. In battle, catapult shots and spells tend to smash apart piles of wood or beams that have no bearing on the ship's structural integrity. In fact, the catapults the orcs mount on their ships normally fire debris hacked from the Junkheap's hull.

**Orc Junkheap:** Huge Sky Ship; HD 40; hp 220; AC 3 (ship -5, size -2); Hardness 5; Speed 40 ft.; Maneuver Poor; Crew 100; Dimensions 40 ft. by 120 ft., 4 decks; Cargo 25 tons; Weapons 2 light catapults, ramming attack (16d8 damage); Market price 33,100 gp.

*Special:* Because of (or perhaps despite) its ramshackle construction, the Junkheap is an incredibly durable ship. When damaged in combat, there is a good chance that any attacks smash into useless or already smashed portions of the ship. When a Junkheap takes damage, there is a 20% chance the ship ignores the damage. The spell, attack, or other effect merely blasts away a pile of junk or smashes superstructure that did not play a role in the ship's structural integrity.

Each time the orcs fire one of their catapults, there is a 25% chance that the orcs' hacking ammunition from their ship deals 1d4 damage to the Junkheap.

### Overlord Zeppelin

High in the distant mountains, ancient feuds between dwarf kingdoms and orc clans continually erupt into all-out war. While the orcs have the advantage of numbers and ferocity, the dwarves counter with their magic, keenly craft-

ed weapons and armor, and their awe-inspiring war machines. The Overlord ranks amongst the mightiest of their machines. This monstrous zeppelin soars through the sky, dropping catapult and ballista fire upon the dwarves' enemies and sending them scurrying for cover. In some regions, Overlords relentlessly patrol mountain passes in search of orc raiders and other threats. In others, the Overlord serves primarily as a trader and transport, ferrying goods from the dwarf citadels high in the mountains to distant markets in the city of men.

The Overlord's decks are set with firing holes for crossbows and other weapons, while its upper balloon is set with armored plates that help it shrug off arrows, boulders thrown by giants, and other threats. The mere sight of one of these colossal war machines is enough to send many orc tribes fleeing for their dark cavern homes.

**Overlord:** Colossal Zeppelin; HD 75; hp 412; AC 1 (ship -5, size -8); Hardness 10; Speed 30 ft.; Maneuver Average; Crew 175; Dimensions 60 ft. by 180 ft., 6 decks; Cargo 200 tons; Weapons 32 ballistae, 6 light catapults, 10 heavy catapults, ramming attack (64d8 damage); Market price 408,850 gp.

*Special:* Each of the Overlord's decks is set with firing slits for crossbows, blunderbusses, and other weapons. In battle, up to 60 archers may fire along the zeppelin's long edges, while 20 may fire from its front or rear.

The Overlord's balloon has AC 5 and 800 hit points. Its armor class is enhanced by metal plates attached to its outer air cells.

### Scow

Slow and ponderous, the scow is a common ship of merchants and traders. Scows rely on other ships for defense. When traveling through dangerous areas, they only rarely venture forth without a few Javelins or a Warhawk watching over them.

**Scow:** Huge Sky Ship; HD 35; hp 192; AC 3 (ship -5, size -2); Hardness 5; Speed 80 ft.; Maneuver Clumsy; Crew 100; Dimensions 40 ft. by 120 ft., 4 decks; Cargo 25 tons; Weapons ramming attack (16d8 damage); Market price 78,400 gp.

### Sky Elf Warhawk

The undisputed king of the sky elf air lanes, the Warhawk is a mammoth warship that serves as the elf navy's ship of the line. A squadron of five Warhawks can send most monsters and enemy formations scurrying in fear.

**Warhawk:** Gargantuan Sky Ship; HD 50; hp 275; AC 1 (ship -5, size -4); Hardness 5; Speed 80 ft.; Maneuver Average; Crew 200; Dimensions 80 ft. by 240 ft., 5 decks; Cargo 100 tons; Weapons ballista x4 (forward arc), ballista x4 (rear arc), heavy catapult x2 (forward arc), heavy catapult x2 (rear arc), ramming attack (32d8 damage); Market price 247,200 gp.

### Stinger Autogyro

A tiny, one-man aerial machine, the Stinger is designed to drive off flying creatures that threaten dwarf caravans or approach strongholds from above. The Stinger is quite fragile, as its hull is little more than a wood and steel frame sup-



porting a pilot's seat, landing gear, and the autogyro's rotor blades. In battle, the Stinger relies on its supreme swiftness and speed to dodge attacks and approach close enough to the enemy for the pilot to fire a crossbow or cast a spell. Most Stinger pilots are apprentice wizards drafted into service aboard these ships. The Stinger has two heavy crossbows mounted on its lower body.

**Stinger:** Small Autogyro; HD 1; hp 5, AC 15 (+1 size, +4 natural); Hardness 2; Speed 80 ft.; Maneuver Perfect; Crew 1; Dimensions 5 ft. by 10 ft., 1 deck; Cargo 250 pounds; Weapons 2 crossbows, ramming attack (2d8 damage); Market price 580 gp.

**Special:** The Stinger is equipped with two heavy crossbows fired at pilot's base attack bonus. A simple mechanism allows the pilot to load both weapons with a standard action. Each crossbow carries 20 bolts.

### Undead Horde Ship

The undead horde ship stands as one of the most horrifying sights a sky captain can encounter as he travels the air lanes. Crafted from the bones of rocs, wyverns, and other great flying creatures, this "ship" is actually a gigantic, undead construct. From a distance it appears to be an extremely large, flying skeleton. Closer inspection reveals that the horde ship is a carefully constructed vessel built from bones and sinew. Its main hull is constructed from rib bones and reinforced with wooden planks. Two long, snaking arms composed of a multitude of smaller arm bones end with skeletal hands taken from a fire giant or similar creature. The horde ship is a semi-sentient creature, though it gladly serves an undead captain or necromancer who sits upon its throne of bone.

Necromancers normally build horde ships as their personal sky chariots, while those with a bent for conquest love to construct fleets of these vessels, crew them with ghouls and wights, and set them upon the airways to wreak havoc and spread terror across the land.

**Horde Ship:** Medium Undead Hulk; HD 10; hp 65; AC 11 (-5 ship, +6 natural); Hardness 0; Speed 120 ft.; Maneuver Perfect; Crew 0; Dimensions 10 ft. by 30 ft., 2 decks; Cargo 1000 pounds; Weapons ballista, ramming attack (4d8 damage); Market price 24,000 gp.

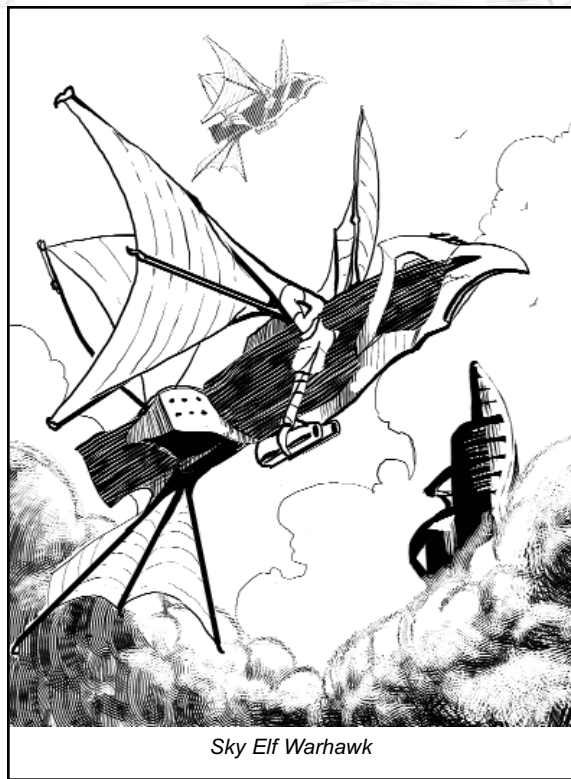

Sky Elf Warhawk

**Special:** The horde ship has the aura of death, necromantic affinity, necromantic defenses, and sentient craft abilities listed under the undead hulk template. In addition, this ship is normally manned by a small horde of undead creatures. The typical group of undead consists of 12 human skeletons, 6 human zombies, 4 ghouls, 2 ghasts, and a wight captain. In addition, the horde ship has a pair of tremendous, clawed arms it uses in battle to swat at flying attackers and smash enemy ships. The horde ship has 20 feet of reach with these two arms, attacks with them at a base attack bonus of +8 and deals 1d12+3 damage per hit. It may attack with one claw as a standard action or with both as a full-attack action.



## Chapter Four

# The Sky Realms



The sky realms are a mysterious place. Cloud cities come and go with the drifting of the winds, while mysterious winged creatures migrate vast distances in a single week. Some “terrain features” are permanent (such as persistent rainstorms or clouds that orbit in a fixed pattern), while others are completely unpredictable (such as cloud cities that move entirely at the whims of the wind).

This chapter introduces several locations to be used in populating your sky realms. The most important is Sellaine, a major sky elf city and trading hub for the sky realms. It makes a great base of operations for any campaign. Alongside Sellaine are several other locations and points of interest, which you can incorporate at your whims: the Dreadfall, a horrid necromantic cloud that is rarely seen; Fulgash’s Tower, a strange relic of the surface world that floats about haphazardly; the Wildlands, a mysterious living cloud that is the legacy of a titan who tried to play god; and the black orcs of Noctilius Point, a band of bat-riding orc raiders who terrorize the skies around them.

Finally, this chapter also discusses some of the notable encounters and NPCs of the sky lanes: the alien derelicts, the annoying Sage of Air, and the secretive Captain Lebeyewn of *The Quest*.



## Sellaine, Jewel of the Clouds

A glittering jewel of the clouds, Sellaine is a political, economic, and military hub of the cloud realms. The city commands few resources of its own. In fact, the cloud realm is barely large enough to accommodate much more than the city. Most civilized realms include forests, low hills, large fields of grain, and orchards. Sellaine rests upon a cloud realm that resembles an upside-down cone. Plains extend from the realm’s upper reaches, giving it a convenient stretch of land for fields to support the city’s inhabitants. Other than that, Sellaine commands no natural resources.

Generally, cities arise for one of two reasons: location or resources. Luckily for Sellaine, the city is one of the most critical points in the tenuous web of trade and diplomacy that exists amongst the cloud realms. As the seasonal winds blow, cloud realms drift across the sky. While the general wind patterns make possible rough predictions of a particular cloud’s location, the vagaries of the weather and the exact location of a given realm make trade difficult. Sellaine is one of the very few exceptions to this general rule. Floating high in the atmosphere, it follows the same path year after year. Some sages believe Sellaine is blessed by the gods to adhere to its course. The sky elves, an offshoot of the elf race that dwells amongst the clouds, believe their god Laelus created Sellaine as a boon to his people. According to legend, this cloud realm is the center of sky elf civilization and the first realm the elves civilized when they came to the clouds. After that initial settlement, elf settlers dispersed across the sky to establish their empire and civilize the skies in Laelus’s name.

Sellaine’s predictable location makes it the ideal trading center for all the sky realms. As it moves through different regions of the sky, traders swarm from across the air lanes to meet at the city, sell their wares, and load up cargoes of worked goods and raw materials that are rare in their home realms. If travel between the air and ground is common in your game, surface merchants funnel the vast majority of their trade through Sellaine. While some traders may deal with other cloud realms, most lack the resources and interest to track down settlements as they drift across the sky. Sellaine’s status as the pre-eminent trading port of the sky ensures that a surface merchant can find a market for his goods and a wide range of products to carry back home.



## The Basics

**Population:** 15,000 (12,000 elves, 1000 dwarves, 1000 halflings, 600 humans, 300 gnomes, 100 other)

**Government:** Republic

**Military:** Standing army of 800 elf warriors, including corps of 80 wizards, 100 clerics, and 20 bards. Navy includes a dozen flying skyships.

## History

Sellaine’s history extends back thousands of years. It was one of the first realms settled by the sky elves and as their legends claim it was created by Laelus as a beacon and central point for all of sky elf civilization. Over the years, the city has seen its share of prosperity and disaster, yet its critical location and status as a religious site ensures that it remains in sky elf hands.

The most important and tragic event in the city's history is known as the Night of a Thousand Fires. Water is a valuable resource in any cloud realm. Many realms lack large bodies of standing water, instead relying on the frequent rain of the upper atmosphere to keep their crops healthy and supplies of water on hand. While most realms receive enough rainfall to sustain life, fire is a critical threat to any cloud city. As bad as it is on the surface, few settlements can afford to maintain large reservoirs necessary to combat an inferno. A small cabal of diabolists decided to ally with the powers of hell to set the city aflame. Protected by their magic, the foul wizards planned to pick through the disaster and claim any appealing treasures they discovered. Their plan almost succeeded. Summoning forth a small horde of fire demons, the cabal succeeded in destroying most of the city's upper spires. The city's defenders were distracted as the flames threatened to spread throughout town, allowing the wizards and their diabolic allies to move through the temple district unmolested. As luck would have it, an acolyte of Laelus spotted the marauders and sounded the alarm. While the fire prevented the majority of soldiers from responding, a small corp of paladins, clerics, and sorcerers rushed to deal with the attackers. The wizards and the devils who worked with them were defeated, preventing the theft of many religious icons and artifacts. Furthermore, the devil's defeat forced back to the outer planes the minor devils summoned to set fires and spread havoc through the city. Still, the damage to the city was quite extensive and took several years to rebuild.

As a result of that episode in the city's history, wizards, sorcerers, and all other spellcasters are required to register with the town guard. In addition, magic items of all types must be reported to the authorities. Incoming ships are met by a small squad of soldiers led by a cleric of Laelus who uses *detect magic* to spot enchanted items. Items capable of producing fire spells, such as *burning hands* or *wall of fire*, are confiscated until the owner leaves the city. Spellcasters must register with the city and report to a guard post each day. Casting any sort of offensive spell, even one that cannot possibly cause collateral damage such as *magic missile*, is punishable by a week in jail and a 100 gp fine. Needless to say, wizards who wish to remain out of sight had best seek a safer harbor. On the other hand, a wizard can rest assured that his enemies had best rein in their magic while in town.

Aside from that incident, the city has weathered its share of attacks, sieges, and pirate raids. Twice the elves have been forced from its walls, though each time they have returned with a crusading force and crushed those who would seize their ancestral home. The city has not been attacked in almost 400 years, as any would-be raider knows he would have to deal with the wrath and power of the entire sky elf race. The city's position as a critical cog in the aerial trade routes also ensure that most races and realms look upon it as too valuable to their economic prosperity to attack it. It is said that a would-be conqueror has a better chance of making a fortune and claiming power in Sellaine's bustling markets than at its stout walls.

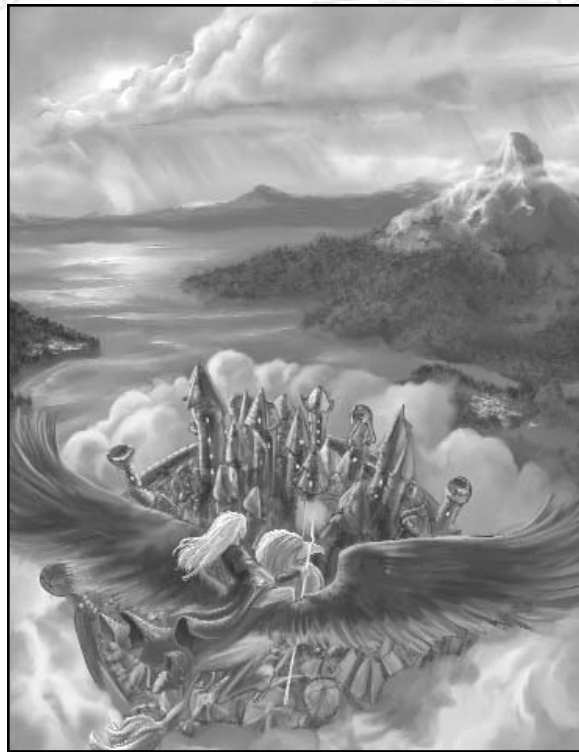

## Government

The governance and administration of Sellaine is a major concern of traders across the skies. Tariffs, regulations, dock fees, and other laws relating to trade in the city have major repercussions across the air lanes. Few traders would not feel the pinch should the city's lords opt to raise taxes or restrict the movement of certain goods. Thus, Sellaine's politics are a common topic of conversation both within and without the city.

Sellaine is simply too important an economic, religious, and cultural center for a single sky elf or line of elves to rule over it. Instead, a council of nobles rules over the place. This council's seven members are elected by a popular vote amongst the Gathering of Esteemed Citizens, known as the Gathering for short. Voting rights within the Gathering are purchased from the city, with a yearly fee of 1000 gp required to gain them. The size of the electorate varies from year to year. A majority of it must be comprised of elves who can claim ancestry to one of twelve families that originally settled the cloud realm. The remaining portion must consist of 50% elves who pay the voting tax. The balance is non-elves who maintain a permanent dwelling in the city and also pay the tax. These laws are currently very hotly contested amongst the merchants and nobles. The nobles feel that the level of representation is sufficient for the non-elf traders' voices to be heard and noted, while the humans, dwarves, and gnomes who do business within the city argue that their miniscule representation makes it impossible for them to have any real say in policy. The non-elves are essentially forced to ally with elf noble houses in order to push legislation they support and candidates they back. However, the elves are normally closely divided on issues, making the support of the non-elf merchants a critical part of any election. Some elves consider this state of affairs wholly repugnant



## Political Players

The two main factions within Sellaine are the traditionalists, who favor a return to a more centralized government run exclusively by elf nobles, and the progressives, who believe that as a cosmopolitan city Sellaine should have an inclusive government.

The traditionalists are led by the Tananliel family, the oldest and most respected noble family in the city. A Tananliel first discovered the cloud realm that became Sellaine, and since then the family has played a key role in every major event in the city's history. The Tananliels own much of the prime real estate in the city and funded many of the expeditions that created some of the most prosperous elf settlements in the sky. They earn most of their income from rent and their shares of merchant companies. Most of the Tananliels are heavily involved in the hierarchy of Laelus's worship, and clerics and paladins of that god are common amongst their number. While morally upstanding, they have a tendency to see the worst in the non-noble classes and place more stock in a person's bloodlines than his actions. Their reputation as holier-than-thou, arrogant moralists wins them little support amongst the new breed of traders and explorers.

House Sylviel, an elf clan of traders and merchants, heads the progressive movement. They believe that Sellaine is at its heart a trading city. In their opinion, mercantile concerns must become the primary guiding force in the city's policies. To this end, they readily support any legislation that undermines the old guard's authority. While this makes the Sylviels popular amongst the humans, dwarves, and working-class elves, their support comes with a healthy load of baggage. Many believe the Sylviels made their fortune in smuggling and other illegal practices. Though none suspect them of murder or other capital crimes, it is well known that in any port the Sylviels do business, their representative spends as much time with members of the thieves' guild as they do in the marketplaces. In many ways, the Sylviels' involvement with the progressives draws much of the traditionalists' opposition to that group's policies, yet without the Sylviels' money and influence the progressives would have little voice in politics.

Standing between the progressives and the traditionalists is Admiral Menathius Truewind, commander of Sellaine's fleets by appointment of the elven nations. As the seat of commerce and elf culture in the skies, the defense of Sellaine is deemed the responsibility of all allied elf realms. Primarily as a tool to ensure that the city is properly defended despite the machinations and political dueling of the Gathering, elf settlements send contingents of elite soldiers and squadrons of sky ships to man Sellaine's walls. In addition, a council of admirals selects the garrison's commander. Truewind gained this post for his skill and daring in destroying a pirate fleet and the great red wyrm that had brought the marauders together. He is a gruff, straightforward, apolitical man who finds the eternal bickering that plagues the Gathering bothersome at best. He would much prefer that the uppity Tananliels and the corrupt Sylviels would go to hell and leave him and his garrison alone. The admiral is normally required to attend state functions and important social events in full uniform, a situation he detests. Many of the politicians grumble that Truewind spends more time organ-

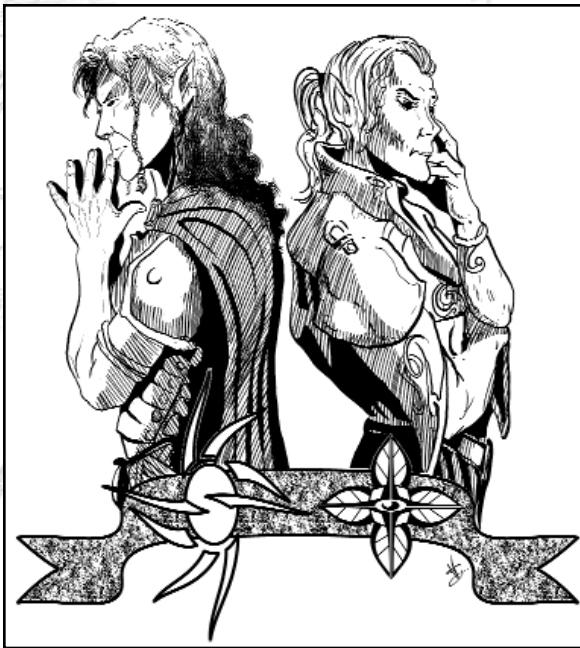

and insist that only elves have a right to rule Sellaine. This debate comprises the major split amongst elves in Sellaine, with the old guard, traditionalist nobles fighting to maintain control of the city while a new generation of merchant princes and pioneers allies with the non-elves to claim supremacy. The current rumor is that the old guard families plan to allow only three of their number to buy voting rights, using intimidation and economic pressure to stop others who may support the other factions from paying for votes. Though farfetched, this scheme would guarantee the traditionalist faction an indomitable majority in the Gathering which in such a case could total no more than five members. The city's charter makes no stipulation for a minimum number of voters within the Gathering, only that they pay their fee and the proper proportions are reserved.

The council's seven members are charged with appointing bureaucrats, drafting laws, and dealing with the day-to-day administration of the city. All drafted laws are voted on by the Gathering, though only the council may prepare and present laws to that body. Furthermore, all prospective legislation must be first approved with a majority vote of the council. Thus, in many respects the council approves the laws. As the council is elected by the Gathering, their votes normally reflect those of the Gathering's membership.

Entrance into the Gathering can be a tricky business. Each year, a new Gathering is created from amongst those who can pay their fee. In addition, each year a single space on the council must be voted on, thus giving a council member a seven year term. The bureaucrats process the applications and fees of the nobles first to determine the Gathering's total size for that year. The remaining spaces are given out half each to non-noble elves and non-elves. A seniority system ensures that those with the most years service in the Gathering are given seats first. These years need not be served consecutively, leading some factions to trot out retired, and often senile, oldsters to secure votes during critical years.

izing punitive expeditions against nearby monster lairs and pirate holds than worrying about the city's defenses. The admiral publicly responds that a good offense is a better defense, while secretly he simply loves the thrill of battle and would much prefer a more active appointment. Anyone who raises havoc for the Tananliels and Sylviels is a gentleman of the first order in his book.

The council's seven members are amongst the most powerful people in the city. They are:

**Luvien Tananliel:** The eldest of the Tananliels, this elvish crone is a staunch traditionalist who would much rather see every last being who cannot claim noble blood exiled from the city.

**Pendra Tananliel:** Once an adventuring paladin of Laelus, Luvien's granddaughter is a moderate amongst the traditionalists. She believes that the nobility has the right to rule, but is not opposed to granting the merchants and commoners a voice.

**Ragast Sylviel:** The youngest of the council members, Ragast is a playboy and hedonist who embodies everything the Tananliels fear. Ragast has little respect for the nobility and consistently pushes to undermine their rule. He frequents the brothels and gambling houses in the city's slums and cultivates a populist image. Rumor has it he dabbles in the narcotics trade.

**Dellir Silvercloud:** For years, Dellir served in the sky elf navy before returning to his native Sellaine. The scion of a traditionalist noble house, his military training and desire to judge each issue in terms of its utility to the city makes him the most moderate of the council's members. His vote is often the one that decides a deadlocked issue.

**Taern Skywander:** Taern made his fortune seeking out isolated cloud realms for trade and exploration. A staunch progressive, he believes the nobility is too static and complacent to remain in power. He frequently uses analogies and stories drawn from his days as a merchant captain to make his point.

**Lindriel Sunstream:** The daughter of Lilo Sunstream, a famed elf adventurer, explorer, and merchant queen, Lindriel loves politics for their own sake. She backs the progressives because of the improvements they promise her family, but is driven more by the love of a good struggle against crafty opponents than her belief in their agenda. Ragast has made several attempts to seduce her, but she considers him a soft, spoiled, brat.

**Mercir Stargem:** The oldest elf on the council, Mercir's primary concern is the city's security and law enforcement. Much to Admiral Truewind's dismay, Mercir continually demands his presence at debates and meetings in order to receive the military's point of view. Mercir is old enough to recall the last attacks on the city and knows that unless Sellaine is a safe port of call, it will lose its status as the preeminent trading port in the skies. Mercir supports the traditionalists out of loyalty to his noble house and because he believes the stability offered by noble rule translates into Sellaine's best defense against attack.

## Getting Around Town

Since Sellaine's buildings are set within a roughly cone-shaped cloud structure, getting around town can be a challenge. Travelers need to worry about moving up and down



terraces and also around any particular level. Each terrace is set up as a concentric ring within the cone. A single primary street runs down the middle of each ring, with smaller streets running off the sides. Two main thoroughfares, Gold Street and Silver Street, run from the main dock areas all the way down to the very bottom of the city. Where they run between each terrace, wide sloped platforms allow traffic to run directly up and down between levels. These two streets do not run straight. Rather, they snake down to the bottom primarily to keep the roads' slopes manageable. A direct path would prove a bit too steep for a comfortable trip up or down.

To expedite travel, flying ships similar to rowboats with small sails shuttle across the city's central space and between levels. In some areas, these scoot boats, as they are called, are as thick in the sky as a swarm of flies. Common practice requires a would-be passenger to hold a hand in the air and look upward to draw a scoot boat's attention. The standard fare is 1 sp per level up or down and an additional 5 sp for going across town.

## Law Enforcement

The city is patrolled by groups of six elf warriors normally accompanied by a cleric of Laelus or a wizard who specializes in offensive magic. The warriors are first level, while the cleric or sorcerer is second. The city also maintains an elite battalion of 100 4th-level warriors.

The guards react quickly to any outbreak of violence. As crime is bad for business, the dock areas and markets are heavily patrolled. The lower reaches of the city are much less closely watched.

The most important offense in the city is arson. Anyone caught using fire magic or setting a building aflame faces a jail term of 10 years and a 5,000 gp fine. Any use of offensive spells nets the violator a 100 gp fine and a week in jail.



This penalty is often waived in cases of self-defense, but outsiders or those suspected of criminal activity are not given the benefit of the doubt.

Other crimes are divided into petty violations that net 5 gp fines, minor crimes such as robbery that include 1-4 years in prison and a 500 gp crime, and major crimes that have terms of up to 10 years and 1000 gp fines. Murder is punishable by death, as are any other acts that threaten the safety and security of the city. Trials are administered by magistrates appointed to their post by the city's ruling council.

A typical city patrol has the following statistics.

**Typical Sellaine Guardsman, sky elf War1:** CR 1/2; Medium humanoid; HD 1d8; hp 4; Init +1; Spd 20 ft. (30 ft. base); AC 18 (+1 Dex, +5 armor, +2 shield), touch 11, FF 17; BAB +1; Grp +1; Atk/Full Atk longspear +1 melee (1d8/x3) or shortsword +1 melee (1d6/19-20) or longbow +3 ranged (1d8/x3); SQ Elf traits; AL LG; SV Fort +2, Ref +1, Will +0; Str 11, Dex 13, Con 10, Int 10, Wis 11, Cha 9.

**Skills:** Listen +2, Spot +2. **Feats:** Weapon Focus (longbow).

**Possessions:** Longspear, short sword, longbow, 10 arrows, large shield, chainmail, alarm whistle.

**Cleric of Laelus, sky elf Clr2:** CR 2; Medium humanoid; HD 2d8; hp 12; Init +1; Spd 20 ft. (30 ft. base); AC 18 (+1 Dex, +5 armor, +2 shield), touch 11, FF 17; BAB +1; Grp +1; Atk masterwork heavy mace +2 melee (1d8) or light crossbow +2 ranged (1d8/19-20); SA Spells; SQ Turn undead, domain abilities (Air, Good); AL LG; SV Fort +3, Ref +1, Will +5; Str 10, Dex 12, Con 11, Int 10, Wis 14, Cha 11.

**Skills:** Concentration +5, Knowledge (religion) +5. **Feats:** Combat Casting.

**Domains:** Air, Trickery.

**Spells** (4/3+1; save DC 12 + spell level): 0 – *detect magic* (x2), *detect poison*, *light*; 1st –  *Bless*, *command*, *magic weapon*, *protection from evil*.

**Possessions:** Masterwork heavy mace, light crossbow, 10 bolts, large wooden shield, chainmail, holy symbol, alarm whistle, *potion of cure light wounds* (x2).

**Sellaine Watch Wizard, sky elf Wiz2:** CR 2; Medium humanoid; HD 2d4+3; hp 9; Init +1; Spd 30 ft.; AC 11 (+1 Dex), touch 11, FF 10; BAB +1; Grp +0; Atk staff +1 melee (1d6) or masterwork light crossbow +3 ranged (1d8/19-20); SA Spells; SQ Owl familiar; AL LG; SV Fort +0, Ref +1, Will +3; Str 10, Dex 13, Con 10, Int 14, Wis 11, Cha 9.

**Skills:** Alchemy +7, Concentration +5, Knowledge (arcana) +7, Spellcraft +7; Spot +0 (+3 in shadows). **Feats:** Toughness.

**Spells** (4/3; save DC 12 + spell level): 0 – *daze*, *detect magic*, *mage hand*, *ray of frost*; 1st – *mage armor*, *magic missile*, *animate rope*.

**Possessions:** Staff, masterwork light crossbow, 10 bolts, 50 ft. rope, alarm whistle, *wand of detect magic* (40 charges), *potion of cure light wounds*.

## Sellaine: A Gazetteer



Sellaine is nestled within an inverted, roughly cone-shaped cloud realm. Plains stretch out from the uppermost reaches of the realm, forming space for fields and orchards that supply the city with food. The city is built upon a series of terraces formed along the cone's interior. Stairways and gently sloped ramps connect one level to another. The upper levels, called the spires, are given over to docks, guard towers, and the mansions of Sellaine's richest families. The higher up along the city a building is located, the more sunlight and fresh air it receives. Thus, the topmost areas comprise the city's most expensive real estate. The middle terraces are known as trade town, so named because of the many foreign merchants that live there and the presence of markets and warehouses in that region of the city. Below trade town is the undercity, a place where the town guard rarely ventures. Dockworkers, servants, and other laborers live there and the thieves' guild operates gambling houses, brothels, and other dens of vice in that area.

### The Spires

The fields surrounding the city's topmost levels and the first four terraces within the cloud realm comprise the spires. Named for the soaring guard towers built here, the spires are walled off into two distinct portions. The dock areas are the destinations for incoming ships. Warehouses, merchant guilds, and other businesses tied directly to commerce are all found along three distinct strips that radiate inward to the city. The dock areas take up roughly half of the spires. The other half is given over to the temple district and the estates of the noble families that have lived in Sellaine for generations. Some families maintain small estates within the spires while others live in mansions built amongst the fields that surround the city's upper most levels. Most merchant families earn their income from renting land to tenant farmers or selling their crops to the city.

### Dock Ward

Serving as a port of call for skyships and traveler from across the air ways, each dock ward consists of berths for incoming ships, warehouses to hold incoming and outgoing trade goods, and a few boarding houses and taverns for visitors. This area is heavily patrolled, owing to its proximity to the noble estates. Unlike most cities, Sellaine has a rather clean, peaceful, and secure sky dock district. Long term visitors are encouraged to move downward to trade town or the undercity. Sellaine law prohibits anyone from renting lodging here for more than two weeks at a time.

Dock ward is surrounded by stone walls. Gates built within them allow access to the noble and temple districts, but these are closed at night and visitors are not allowed through unless they bear a letter of recommendation from a noble family.

**The Gull's Nest:** This boarding house is typical for the dock ward. Kept freshly whitewashed and neatly appointed within, it generally serves merchants and travelers rather than sailors, who prefer to seek out the undercity for lodging



# Sellainę

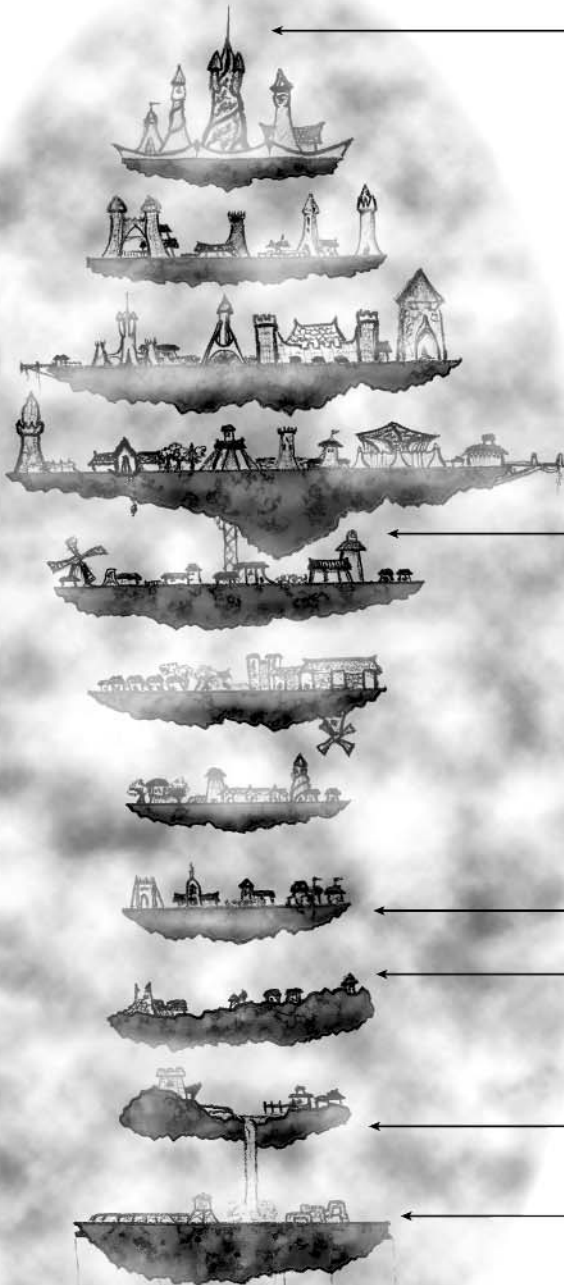

## **SPIRES**

The top four levels are where the aristocracy dwells. These are beautiful neighborhoods filled with towers, spires, temples, and other amazing districts. Many of the spires rise high above the cloud's surface.

## **TRADE TOWN**

The next four levels are the trade town, home of merchants, factories, guilds, pubs, normal residents, and so on.

## **UNDERCITY**

The bottom two levels are the dank, dark undercity.

## **SEWERS**

Spilling out of the undercity, through the cloud and then out from beneath it, are the sewers.

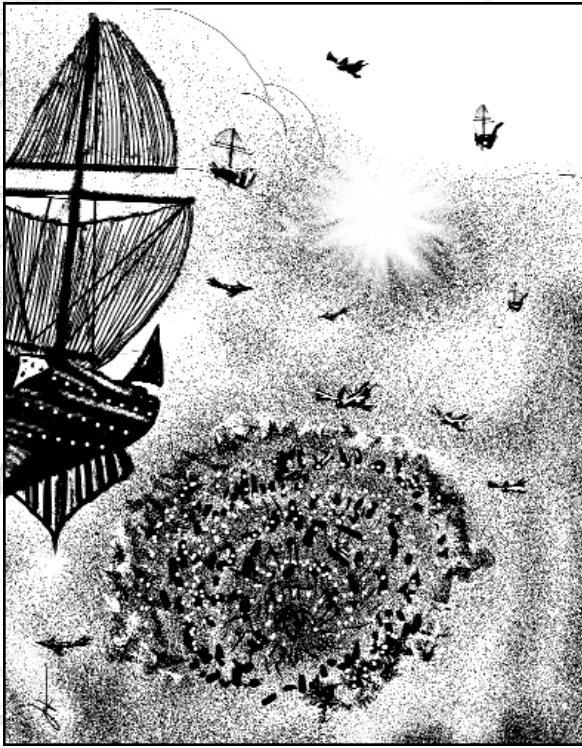

and entertainment. Phaerla Strongwind (female sky elf Exp4) is an elderly woman who watches after her guests with a grandmother's dotting concern.

**Morgan's Tankard House:** One of the most popular meeting places for merchants and traders who come to Sellaine to do business, Morgan's offers discrete meeting rooms and a lively common room with nightly musical performances. Morgan Silvershield (male dwarf Exp4) owns this place, helps tend bar, and runs himself ragged seeing to it that each and every one of his guests enjoys the food, drink, and ambience of this place. Morgan is the most respected dwarf in the city and the informal leader of that tiny faction. A dedicated progressive, he commonly hosts political meetings and social gatherings.

## Gold Coast

The gold coast, the popular name for the noble district, hosts the city's nobility and the farmland that extends outward from the edge of Sellaine. The rolling fields outside of town are peaceful and quiet. The farmers who live here generally grew up on the land they tend and take a dim view of city dwellers. Many of the families here have long traditions of service to the noble houses. Most tend the fields in return for a portion of the profits derived from the sale of crops in the market. Many noble families live out amongst the fields, preferring the open air and abundant sunshine to Sellaine's cramped interior.

**Tananliel Estates:** The largest of the noble estates, this sprawling mansion and the grounds around it are the site of the city's most important social and political events. The mansion serves as a home for most of the Tananliel who live within the city. The main building holds kitchens, servants' quarters, and living space for the current head of the family, Luviel Tananliel. She, her husband, and their unmarried children hold court there. Several expansions and wings

added to the main structure hold separate quarters for the rest of the family. During warm weather, the Tananliels commonly hold feasts within grand tents set up on their grounds. The most distinguishing feature of this estate is the large hedgerow maze on the grounds.

## Temple District

Dominated by the grand cathedral to Laelus, this area of the city is one of the most important sites to sky elves across the world. As Sellaine is the gift of their god Laelus, the sky elves have worked hard to honor that gift with soaring cathedrals, beautiful parks, and masterwork sculpture, mosaics, and other artwork. No less than a dozen temples to Laelus can be found here, the newest one (and largest) being one of the most visible structures in town aside from the guard towers. The grand theocrat of Laelus's faith, Paeris Skywander (male sky elf Clr20) holds court here with the rest of Laelus's ecclesiastical hierarchy. A few smaller shrines are built here to accommodate non-elf visitors, but these small structures are kept near the temple district's gates and none are permanently staffed by clerics.

The temple district serves not only as a religious space but as a popular area for relaxation and entertainment. The beautiful gardens and parks built here are crowded on sunny days with merchants and commoners who wish to enjoy the weather. City guards heavily patrol this area, and the presence of many powerful paladins and clerics make this the safest section of the city.

## Trade Town

Comprised of the four terraces below the spires, trade town is where the bulk of business within Sellaine is conducted. Cramped, dark, and crowded compared to the upper terraces, trade town bustles with the dealings of merchants and trading companies from across the world. While safer than the undercity, this place is far less secure than the areas above it.

**Mercenary's Guildhall:** The central gathering place for mariners, soldiers, marines, and others looking for employment aboard skyships, this guildhall is a simple, fortified mansion located in the upper reaches of the trade town. The guild charges a 1 gp fee per month for its members. In return, it serves as a clearinghouse and review board for merchant captains and others who may wish to hire mercenaries. The guildhall takes payments up front for tasks and pays out its members' fees after their contracts are completed. If either the mercenary or employer has a complaint regarding the fee or services rendered, the guild appoints a panel of arbiters to decide the case.

The current guildmaster, a retired merchant named Rollo Finster (male human LN Exp4), takes pride in the guild's integrity and long record of exemplary service. He knows the guild's business is founded on trust and does his best to ensure that all claims and disputes are resolved in an open and fair manner. However, the guild is currently under enormous pressure to sell out to the Sylviel family. Few as yet know of this, but the Sylviels hope to seize control of the guild and use it as a tool to help push their policies. Many of the traditionalist noble houses use retainers, servants, and guards hired through the mercenaries' guild. More importantly, many of their tenant farmers who work the fields out-

side of the city negotiate their contracts through the guild. The Sylviels plan to use the guild and those it represents as a lever to force the city to accept their reforms. Thus far, the Sylviels have been both amicable and secretive in their proposals. As Rollo Finster has no intent to sell a business that has been in his family for generations, the Sylviels may opt to call in their less than reputable allies.

The characters may find themselves dealing with the guild, especially if they work as freelance warriors or commonly hire on with sages, wizards, or merchant holds as part of their adventuring careers. Since the guild holds payment funds and delivers them on completion of a contract, the Sylviel buy-out of the guild could leave the characters unpaid for work, especially if the merchant family allows the thieves' guild to run the business. Once it has served their political needs, the Sylviels are likely to let their investment fall apart.

#### **The Most Glorious Concordance of Arcane Masters:**

A single, five story tower crafted from blue-painted stone is home to the city's wizard's guild. The guild's name reflects its self-perceived status within the city. Clearly a second banana in a city that serves as the religious center of one of the most important faiths in the sky realms, the guild strives to improve its standing and carve a foothold within the political landscape. For centuries, the wizards and sorcerers took a backseat to other groups within the city. The guild was far too concerned with inward politics, research, and other works to bother with mundane politics. Compounding the situation was the attempt by a few wizards to destroy the city many years ago on the Night of a Thousand Fires. All were members in good standing within the guild, and in the aftermath of the attack the guild was blamed for failing to police its members. Since then, the guild has enjoyed little power or popularity. Recently, the emergence of the progressive faction has drawn the guild's attention. For years, the restrictions on magic items and spellcasting were accepted as the status quo. The prospect of reform in the government has fired a desire amongst the younger wizards to seek the abolition of the old laws. The guild has made some overtures to the progressive faction, but the potential stigma of association with the wizards has thus far prevented any formal alliance.

The current head of the guild, Eндarus (male sky elf LN Wiz15) cares little for politics. He prefers to keep the guild separate from outside influences and has no concern for the city's laws. He sees them as tradition and nothing more. Unfortunately, his tendency to address the younger guild members in patronizing tones has alienated the new generation of guild wizards.

Lendella Firemane (female sky elf CG Wiz7) epitomizes the younger wizards in the guild. She is eager to extend the influence of arcane spellcasters in the city and sees the laws restraining spell use as an unnecessary holdover of Sellaine's history. She is a frequent visitor to progressive meetings, but her fiery temperament and impatience with politics has thus far scared off that faction's leaders. Lendella is determined to find a voice for the wizards of the city, and is currently attempting to raise money to buy seats in the Gathering for her and her likeminded friends. As she lacks money, rumors now circulate that she has agreed to supply the thieves' guild with magical items. As Lendella is known for being both easily angered and rather naive, she could quickly get herself and the entire guild in serious trou-

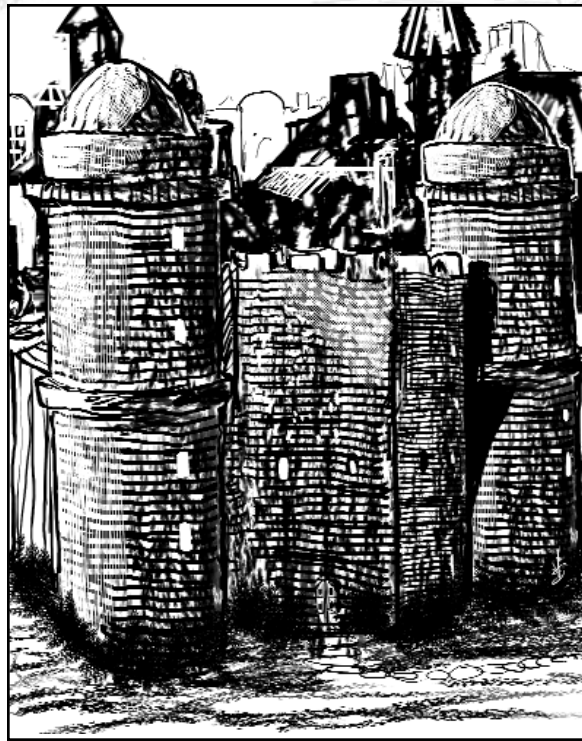

ble with the thieves and the law.

PC mages who wish to join the guild must pay a yearly fee of 100 gp. In return, they are allowed to rent a single room in the guildhouse for 1 sp per night and are given access to its library. Any character with access to the library gains a +2 circumstance bonus to Knowledge checks made there. To join the guild, a potential member must display the ability to cast arcane magic. New members are typically approached by the two political factions within the guild and probed about their leanings and intentions.

**Tylok's:** This place has never been the most prosperous tavern in trade town. A few merchants stop here, usually people who cannot find lodging in the more popular inns or are new to town and know little of the best places for a meal and bed. Tylok's owner, a tall, dark-haired elf named Tellario Quickbreeze (male sky elf LE Rog2), would prefer to keep the place wholly empty, but such a state of affairs would draw unwanted suspicion. Tylok's is the first stop for merchants who wish to deal in illegal goods. The thieves' guild in Sellaine has long enjoyed a monopoly on smuggling, using bribes, raw economic power, and murder to control the flow of drugs, illegal magic items, and other contraband into the city. Tellario sizes up potential customers and puts them in touch the proper merchant. He never deals with newcomers who arrive at Tylok's without an escort from the guild. "He's welcomed at Tylok's" is a common slang phrase in the guild for a thief or merchant who has been accepted as a business partner by the guildmasters.

Tylok's serves as a conduit for trade. Hidden within its cellar are secret passages that run to several hidden galleries and vaults dug beneath the city's terraces. Some of these passages run to the bottom surface of the city, providing convenient ports of call for smugglers and other criminals. The full extent of these passages is described below, in the under-city section.



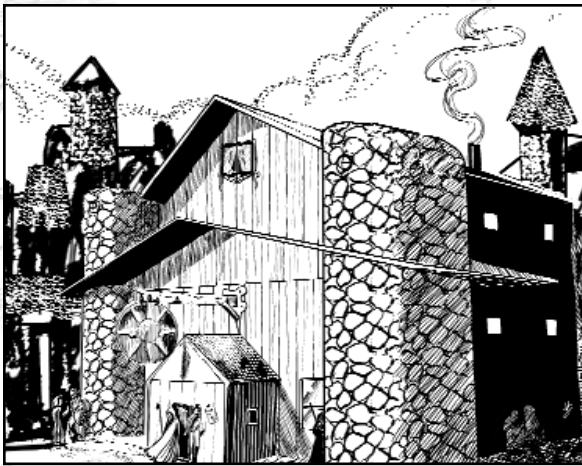

## The Undercity

The bottom two terrace levels and the city's base are considered the undercity. The buildings here are cramped and close together, with crude tenements rising three or four stories into the air. The thieves' guild is the unofficial ruler of this area, as the town guard comes to the undercity only in response to crimes. While the undercity makes up less than a third of Sellaine's area, more than half its population lives here, making it extremely crowded. While visitors to Sellaine typically see only the spires and trade town, those who live here know that the undercity is a much better representation of what Sellaine is truly about. For all the talk of Sellaine as a jewel of the skies, such a label belongs only to the uppermost levels. The undercity is as rundown and violent as the slums in any surface city. However, Sellaine is a city of elves, even if it is populated by the sky elf branch of that race. The people of the undercity tend to have a very strong sense of community. On the good side, they rarely engage in random violence and most visitors have little to fear from muggers or other threats. On the other hand, gang wars and struggles for turf are incredibly common in the undercity. While the thieves' guild controls smuggling and most crime that extends outside of the city, within the city's bounds a wide number of gangs and cartels struggle for power.

## The Gangs

Each gang within the undercity controls anywhere from a few blocks to a quarter of a terrace. The gangs operate beneath the notice of the city's thieves' guild. They primarily engage in localized drug trafficking, purchasing narcotics from the guild and selling them in their territory, or shaking down minor businesses and residents for protection money. Some of the more ambitious ones run brothels, gambling dens, and other illegal businesses. The typical gang member is a 1st-level elf commoner, though in some neighborhoods humans, dwarves, or others form their own gangs.

## The Thieves' Guild

The backbone of Sellaine's criminal underground, the thieves' guild deals primarily in smuggling. None of the

gangs have ever grown large enough to challenge the guild's power, primarily because the guild ruthlessly exterminates all potential competitors in the smuggling business. However, the guild does recruit members from gangs and keeps an eye out for talented street thugs who could prove useful. As Sellaine sits at the center of both legitimate and illegitimate trade, the guild piles up tremendous profits dealing in illicit goods.

The guild has multiple safe houses throughout the city. Its primary headquarters stands on the Sylviel family grounds up on the spires. The trading family's members are the hereditary rulers of the guild and much of their wealth flows from it. Artellus Sylviel (male sky elf N Rog17) is the current guildmaster. A master businessman and shrewd investor, he has doubled the guild's profits by investing money in bribes to the guard, then using the guard to harass and ruin rivals.

The primary secret of the guild's success lies in its control of the sewers. Channels dug beneath the terraced city levels channel waste down to the bottom of the cloud realm. Anyone who can stomach the stench can use these passages to travel anywhere in town in secret. In many areas, the guild has dug out passages, tunnels, and even complexes that serve as warehouses and hideouts. A few of the passages open up beneath the city to small docks used by smugglers to drop off and take on cargo. Once the guild takes on a new shipment, it sells it on to the gangs of the undercity or directly to richer clients in trade town or the spires.

The guild works hard to keep the sewers as safe as possible. Any monsters that somehow end up there are dealt with quickly and efficiently to keep the city government from poking too deeply into the tunnels and to discourage adventurers from delving into them. More than a few curious explorers have met their end at the knives of a guild bravo.

## Locations

The following sites represent common sorts of businesses the characters may visit in the undercity.

**The Golden Disc:** Easily spotted due to the large, wooden icon of the sun hanging above its front door, the Golden Disc appears to be little more than a tavern that caters to sailors flush with earnings picked up at the Mercenaries' Guildhall. The Disc stands at the upper level of the undercity near Gold Street. While the first floor is a typical dive bar, the basement hosts a small casino with dice games, roulette, and other games of chance. A local gang, the Nightwalkers, controls this place. All of the games within are rigged, and the gang is quick to use violence to handle any customers who complain. However, the gang is wary to avoid cheating sober customers, instead preferring to use cheap drinks and cheaper women to keep the sailors entertained while they fleece them of their hard earned gold.

**The Rusty Nail:** A popular drinking spot for rowdies looking for a good bar brawl, the Rusty Nail is renowned as a spot where a night without a fight is an oddity. Bouncers at the door check visitor's weapons, and magical ones have a tendency to disappear from the weapons cabinet. In truth, a halfling wizard named Jendek Singleberry (male halfling NE Rog2/Wiz3) uses *detect magic* to sense enchanted weapons. If the item's bearer does not seem particularly tough, Jendek grabs the weapon and arranges for a few of the Nail's regulars to rough up the owner. In the ensuing struggle, the



bouncers kick the victim out of the tavern and deny all knowledge of his items or give him a mundane weapon. Thus, many of the brawls at this place ignite simply as a vehicle to separate a neophyte adventurer from his possessions. As the Rusty Nail's reputation as a rough and tumble place draws many adventurers, Jendek's scheme has thus far proven quite profitable. Most of the weapons end up for sale via the thieves' guild, which relies on Jendek to supply it with items.

**Undek's Potables:** From the outside, Undek's Potables looks like just another shop specializing in liquor, tobacco, and other vices. While some may feel this place only fuels the city's vices, the truth is far more sinister. Undek's was once the nest for a minor smuggler who was killed by his rivals in the thieves' guild. His murderers never discovered his secret tunnels beneath the shop or the small docking area he had built beneath the city. Unfortunately for the city, the mad aranea prophet known only as the Mouth of Vawn did. The creature worships an enigmatic demonic creature known as Vawn, the elemental manifestation of chaos and destruction. Drawn to the city by a series of visions, the Mouth of Vawn used his considerable magical talents to journey to Sellaine. The voices of Vawn within his mind led him the forgotten smuggler's berth. After exploring, he used his magic to dominate Undek and recruit him into Vawn's cult. Since that day, the liquor store has served as a front for the cult's growing numbers.

The old elf Undek (male elf N Exp3) acts as the cult's front man. While age and drink have long since befuddled his wits, the power of the Mouth's magic compels him and helps sharpen his mind when needed. The Mouth has used his secret entrance to good effect. He used his magic and Undek's connections to make contact with a few smugglers forced out of business by the guild. With their help, the Mouth has set up a steady stream of contraband, weapons, and illicit drugs through his tunnels. He pays higher fees to the smugglers than the guild, helping buy their silence, and his cheaper prices to the local gangs helps keep them quiet. While the Mouth's profits are low, he has still made a considerable sum in a short time.

The Mouth's plans are threefold. He wants to touch off a massive gang war in the undercity by encouraging the gangs to rise up against the guild and seize control of the smuggling business. To this end, he has used his magic to scout out the tunnels and provide information to gangs on shipments of goods, the guild's organization, and other key information to make such strikes successful. The Mouth uses Undek and other dominated servants to spread this information. If the Mouth knew much about human society, it would realize that such a massive, open conflict would send the city into chaos and touch off large scale rioting. All he knows is that in the confusion he is to use an enchanted dagger he discovered to sneak into a human lair in the upper city and kill a particular man. The voices within the spider creature's

head compel him to follow this plan to the letter. In truth, the Mouth of Vawn plots to kill Ragast Sylviel with Pendra Tananliel's stolen dagger. With the riots as a backdrop, this event could send the entire city into a civil war. All the Mouth of Vawn knows is that soon after he kills the human with his appointed weapon, the violence and bloodshed in the city will call out to Vawn and draw him into the material world, completing the prophecies the voices dole out to him.

In the meantime, the Mouth of Vawn waits and watches. The voices tell him that when the stars in the sky reach the proper configuration, it will be time to set his plans in motion.

The Mouth of Vawn is a powerful aranea sorcerer who specializes in enchantment spells. His level and spells should be tailored to your characters' levels, but as a prophet of Vawn he gains the ability to cast *dominate person* as a 12th-level sorcerer three times per day and communicate at will using telepathy as a supernatural ability.

## Using the City

When the adventurers arrive in Sellaine, it is important to remind them that they aren't simply in a city that happens to be floating high in the sky. Describe the buzz of scoot ships as they ferry passengers around town, and the view above, below, and across the city owing to its unique arrangement. The city's inhabitants are a diverse blend of elves native to the city, traders from across the world, and other travelers. Every mode of dress, intelligent species, and trade good found across the world has made an appearance within Sellaine at one point or another.

Sellaine makes a convenient central point for a campaign in the skies. From here, the characters can explore the sky realms. The city itself offers a wide range of adventures. The continuing struggles between political factions, the machinations of the thieves' guild, the gang wars of the undercity, and the growing threat posed by the Mouth of Vawn can all lead to adventures within Sellaine's walls. If the characters are newcomers to the city, especially if they are high level, the various powers within the city may court them as allies. Sellaine is a city that could be headed for tumultuous times, ones that may draw the characters into their center. Don't be afraid to involve the PCs in the plots and politics outlined above. The information given above describes a city on the brink of a political, economic, and social disaster, even if its inhabitants do not yet know that. Where it goes from here is up to you and your players.

Beyond the provinces of the civilized cloud realms are a multitude of wild, unexplored territories. The realms detailed in this section serve as sites to explore and the settings for treasure hunts, battles, and other adventures.

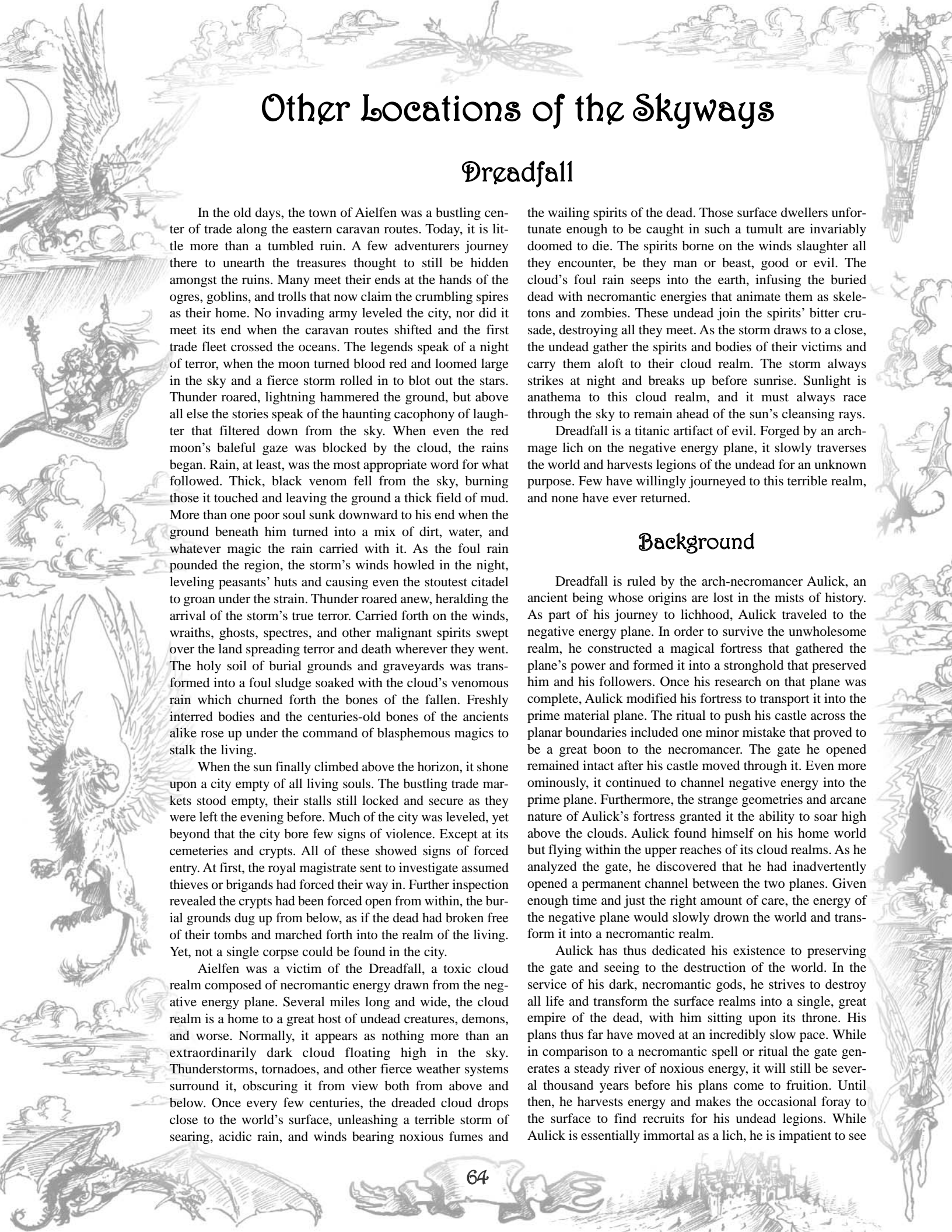

# Other Locations of the Skyways

## Dreadfall

In the old days, the town of Aielfen was a bustling center of trade along the eastern caravan routes. Today, it is little more than a tumbled ruin. A few adventurers journey there to unearth the treasures thought to still be hidden amongst the ruins. Many meet their ends at the hands of the ogres, goblins, and trolls that now claim the crumbling spires as their home. No invading army leveled the city, nor did it meet its end when the caravan routes shifted and the first trade fleet crossed the oceans. The legends speak of a night of terror, when the moon turned blood red and loomed large in the sky and a fierce storm rolled in to blot out the stars. Thunder roared, lightning hammered the ground, but above all else the stories speak of the haunting cacophony of laughter that filtered down from the sky. When even the red moon's baleful gaze was blocked by the cloud, the rains began. Rain, at least, was the most appropriate word for what followed. Thick, black venom fell from the sky, burning those it touched and leaving the ground a thick field of mud. More than one poor soul sunk downward to his end when the ground beneath him turned into a mix of dirt, water, and whatever magic the rain carried with it. As the foul rain pounded the region, the storm's winds howled in the night, leveling peasants' huts and causing even the stoutest citadel to groan under the strain. Thunder roared anew, heralding the arrival of the storm's true terror. Carried forth on the winds, wraiths, ghosts, spectres, and other malignant spirits swept over the land spreading terror and death wherever they went. The holy soil of burial grounds and graveyards was transformed into a foul sludge soaked with the cloud's venomous rain which churned forth the bones of the fallen. Freshly interred bodies and the centuries-old bones of the ancients alike rose up under the command of blasphemous magics to stalk the living.

When the sun finally climbed above the horizon, it shone upon a city empty of all living souls. The bustling trade markets stood empty, their stalls still locked and secure as they were left the evening before. Much of the city was leveled, yet beyond that the city bore few signs of violence. Except at its cemeteries and crypts. All of these showed signs of forced entry. At first, the royal magistrate sent to investigate assumed thieves or brigands had forced their way in. Further inspection revealed the crypts had been forced open from within, the burial grounds dug up from below, as if the dead had broken free of their tombs and marched forth into the realm of the living. Yet, not a single corpse could be found in the city.

Aielfen was a victim of the Dreadfall, a toxic cloud realm composed of necromantic energy drawn from the negative energy plane. Several miles long and wide, the cloud realm is a home to a great host of undead creatures, demons, and worse. Normally, it appears as nothing more than an extraordinarily dark cloud floating high in the sky. Thunderstorms, tornadoes, and other fierce weather systems surround it, obscuring it from view both from above and below. Once every few centuries, the dreaded cloud drops close to the world's surface, unleashing a terrible storm of searing, acidic rain, and winds bearing noxious fumes and

the wailing spirits of the dead. Those surface dwellers unfortunate enough to be caught in such a tumult are invariably doomed to die. The spirits borne on the winds slaughter all they encounter, be they man or beast, good or evil. The cloud's foul rain seeps into the earth, infusing the buried dead with necromantic energies that animate them as skeletons and zombies. These undead join the spirits' bitter crusade, destroying all they meet. As the storm draws to a close, the undead gather the spirits and bodies of their victims and carry them aloft to their cloud realm. The storm always strikes at night and breaks up before sunrise. Sunlight is anathema to this cloud realm, and it must always race through the sky to remain ahead of the sun's cleansing rays.

Dreadfall is a titanic artifact of evil. Forged by an archmage lich on the negative energy plane, it slowly traverses the world and harvests legions of the undead for an unknown purpose. Few have willingly journeyed to this terrible realm, and none have ever returned.

## Background

Dreadfall is ruled by the arch-necromancer Aulick, an ancient being whose origins are lost in the mists of history. As part of his journey to lichhood, Aulick traveled to the negative energy plane. In order to survive the unwholesome realm, he constructed a magical fortress that gathered the plane's power and formed it into a stronghold that preserved him and his followers. Once his research on that plane was complete, Aulick modified his fortress to transport it into the prime material plane. The ritual to push his castle across the planar boundaries included one minor mistake that proved to be a great boon to the necromancer. The gate he opened remained intact after his castle moved through it. Even more ominously, it continued to channel negative energy into the prime plane. Furthermore, the strange geometries and arcane nature of Aulick's fortress granted it the ability to soar high above the clouds. Aulick found himself on his home world but flying within the upper reaches of its cloud realms. As he analyzed the gate, he discovered that he had inadvertently opened a permanent channel between the two planes. Given enough time and just the right amount of care, the energy of the negative plane would slowly drown the world and transform it into a necromantic realm.

Aulick has thus dedicated his existence to preserving the gate and seeing to the destruction of the world. In the service of his dark, necromantic gods, he strives to destroy all life and transform the surface realms into a single, great empire of the dead, with him sitting upon its throne. His plans thus far have moved at an incredibly slow pace. While in comparison to a necromantic spell or ritual the gate generates a steady river of noxious energy, it will still be several thousand years before his plans come to fruition. Until then, he harvests energy and makes the occasional foray to the surface to find recruits for his undead legions. While Aulick is essentially immortal as a lich, he is impatient to see



his plans completed. To this end, he seeds the surface world with undead and, when he has the energy available to plunge his cloud realm close to the surface and unleash its power, he lays waste to entire cities and kingdoms.

## The Storm

Once every four or five hundred years, Aulick takes command of his cloud realm and sends it and his undead servitors to the surface to spread death and terror. The cloud realm changes into a massive, fierce thunderstorm that lasts from midnight until sunrise. During this time, characters caught within the storm face many dangers.

The thunder and lightning are created by necromantic magic. Any character seeing or hearing them must make a Will save (DC 20) or suffer a -2 morale penalty to attacks, checks, and saves for the rest of the night. Each character must make this save only once. This is a fear-based effect.

All undead within the region covered by the cloud gain turn resistance 4. This includes undead dispatched from the Dreadfall to attack the ground below. This bonus stacks with any turn resistance an undead creature may normally receive.

Undead creatures with less than 10 hit dice must make a Will save (DC 25) or fall under the command of Aulick. Those that fail eagerly work with Aulick's minions and travel with them to Dreadfall as the storm ends to serve their new master.

Each minute a living creature spends exposed to the rain, it must make a Fortitude save (DC 20) or suffer 1d4 points of acid damage. Constructs, elementals, and undead are immune to this affect.

All corpses within the storm's area arise as skeletons or zombies under Aulick's command. They attack all living creatures they encounter. If a creature dies during the storm, it arises as a zombie 3d6 minutes after death. Constructs, elementals, and undead are immune to this affect.

During the storm, patrols of undead creatures fly down to the surface or are carried to the surface by the realm's enchanted winds. Specters, ghosts, wraiths, wights, skeletons, and zombies wander the region, attacking any living creatures they meet and fighting to the death.

The storm lasts until an hour before sunrise, at which point Aulick's servants return to their cloud realm. The great winds the realm generates lift the undead creatures into the air and carry them to their home.

Most areas lack the fortifications and magical resources to repel these attacks. Travelers who pass through a region attacked by the Dreadfall find it completely devoid of life. The trees stand withered and dead, the area is utterly silent, and though many signs of violence are present, such as shattered doorways, collapsed walls, and broken weapons, not a single corpse is in sight. The undead carry their victims back to their cloud realm.

## The Dreadfall: A Gazetteer

The characters may choose to visit Dreadfall for a number of reasons. Perhaps they seek to destroy Aulick and end his campaign of violence and terror. Their mode of aerial transportation, such as a sky ship, may become caught in the storms that surround his festering sky realm and be forced to land there. Whatever the reason, few seek out Dreadfall for

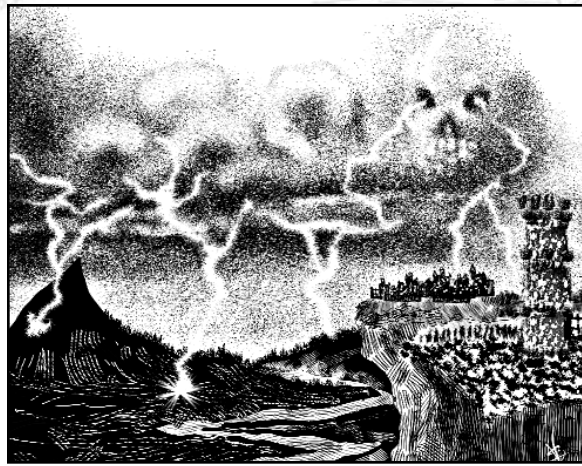

capricious reasons. Their realm has earned its fearsome reputation for good reason. Sky mariners whisper of it as a sky realm of the damned where the most despicable and terrible souls journey after death. Others say that the Dreadfall is a cloud belched forth from the depths of hell, a floating realm where devils cavort and plan their forays into the world. Few suspect Aulick's existence and none know of his plan to eventually flood the world with the stuff of the negative plane.

Of course, given that this cloud realm is a highly dangerous area that hosts endless legions of the undead, a powerful necromancer lich who plans to destroy the world, and untold riches looted from conquered lands, it is the perfect place for a heroic band of adventurers to venture to. The following short guide describes the general features of Dreadfall, stats for a few of its key inhabitants, and information for setting adventures there.

## Geography and Locations

The Dreadfall is a dark, murky place. Its surface resembles a hilly, forested region twisted by dark magic. As this region remains within thick clouds, at best a gray twilight lights its surface. Thick forests of dead trees cover the realm, while the ground is made up of finely ground, gray ash. Water or blood dripped on to it immediately dries up. Any creature other than undead, constructs, or elementals suffers a -2 morale penalty to all attacks, skill checks, and saving throws while journeying within this realm. This is a fear-based effect that does not allow a saving throw.

**The Necropolis:** As this cloud realm first developed, the undead creatures of Dreadfall erected what was at first a crude collection of stone crypts and graves. Over the years, successive infusions of new undead creatures and the growing number of intelligent undead such as vampires, ghosts, and ghouls have transformed the necropolis into a literal city of the dead. Sprawling catacombs dug by skeleton and zombie servitors serve as mass storage chambers for the unintelligent living dead. The same creatures that hew these vaults from Dreadfall's black rock stand within their reaches and wait for the day that their master demands their service. Blasphemous cathedrals dedicated to dark gods rise into the sky, carefully constructed over centuries by undead craftsmen with little else to do on Dreadfall's barren surface. Skeletons clad in chainmail and carrying longswords, light crossbows, and daggers patrol the streets. While one may

think that an army of undead creatures brought together by a powerful lich would live in peace with each other, the truth is far different. Vampire lords, minor liches, ghosts, and other intelligent undead squabble amongst themselves. Aulick is simply too absorbed in his research to bother with policing his followers. While he knows of the struggles amongst them, he considers this a necessary process to ensure that only the most cunning, daring, and ambitious of his followers survive to the day that he finally declares all-out war on the living.

The necropolis is arranged in a series of concentric circles. The innermost area of the city is a large stone fortress that serves as a home to Aulick's most powerful lieutenants, a collection of vampire warriors, lich sorcerers, wizards, and clerics, and ghostly assassins that comprise an elite core of his legions. These undead lords plot against each other unceasingly in hopes of currying favor with Aulick and winning prestige amongst his followers.

Foremost amongst these lieutenants is Pyrla Diresadow (female human vampire LE Ftr15), Aulick's field general and war leader. In life Pyrla was a beautiful, mortal human courtesan Aulick won in a game of chance with a devil lord. The necromancer soon grew bored of the physical comfort she offered and, needing a vessel to house the soul of an ancient, world-conquering general he had called forth, he used a ritual to remove the courtesan's soul and replace it with his new general's persona. Further spells granted his newly minted warleader the blessing of vampirism. Unfortunately, the process was not a complete success. Pyrla retained her personality but gained the ghostly general's combat skills and military knowledge. She now commands Aulick's armies but secretly plots against him. Aulick has miscalculated the effect her physical charms can have on his other undead servitors. Just as intelligent undead can feel anger, hatred, and rage, so too can they feel resentment, jealousy, and infatuation. Even the lich sometimes finds himself forgetting that he deals with a woman who bears the experiences of conquering half the known world and leading tens of thousands into battle, not

simply some bedroom toy he tossed aside. Furthermore, Pyrla has secretly gathered some of her half-devil offspring to her banner. In time, she may rise to topple her master. Until then, she commands the armies of the dead with an iron fist.

Malbeth is a ghostly assassin and rogue (halfling ghost LE Asn7/Rog8) who serves as Aulick's chief spy and killer. Malbeth appears as a bald, charred halfling male. Killed in a fire set by a rival crime lord, Malbeth's desire for revenge was strong enough to pull him back from the grave. After slaughtering his enemies, he took to wandering the world and eventually stumbled upon Dreadfall. After murdering Aulick's current chief spy simply to pass the time with an interesting diversion, the ghost was offered the chance to serve. Eager to find anything to help make eternity more bearable, Malbeth accepted the offer.

Grallian (human lich NE Wiz 13) is the second most powerful spellcaster on the cloud realm, though not for long if Aulick has his way. Justifiably paranoid of another wizard usurping his position, Aulick regularly disposes of those magicians who draw too close to his own power. Over the years, Aulick's paranoia has increased to the point that he sees in a relatively weak mage such as Grallian a major threat to his power. Needless to say, the scheming, fearful Grallian is willing to ally with almost anyone who can help stave off his destruction. A band of adventurers who infiltrated Dreadfall may be the perfect tool to destroy his master.

In addition to the citadel at the center of the city, the concentric rings around it house grim parodies of taverns, trading posts, and other edifices of the living. The undead who dwell here are driven by boredom to recreate the world they knew in life. Minor liches and vampires gather in taverns to feast on blood and flesh of captives, while skeletal servants sweep the streets and labor over forges to produce weapons, armor, and even metal trinkets at the behest of spectral smiths.

The streets are arranged in concentric rings that surround the central citadel. Inner roads house more powerful undead, while the outer ones are for minor creatures and

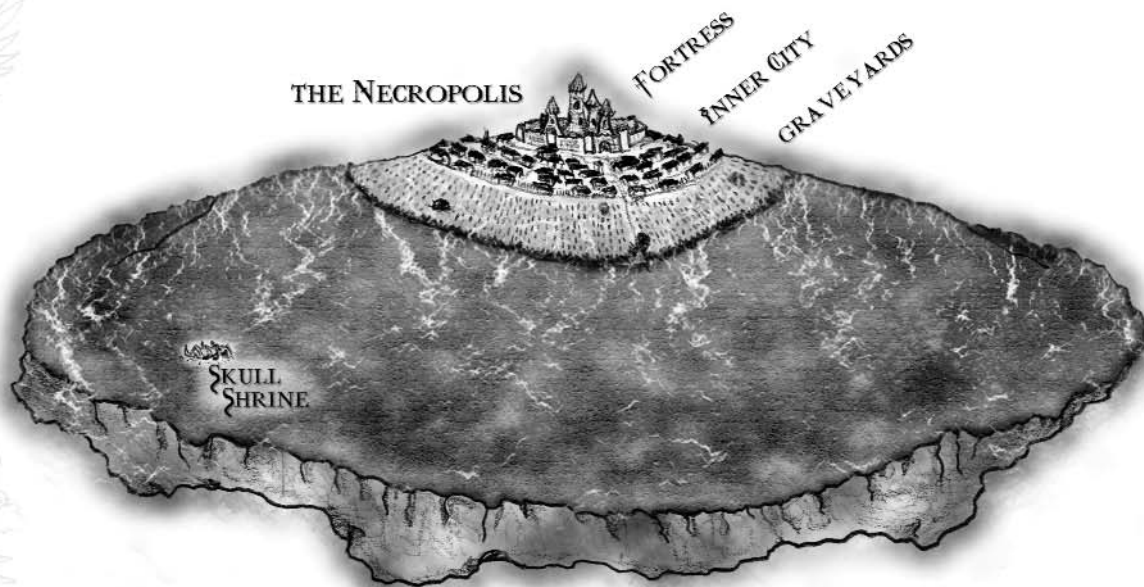

# DREADFALL



servitors. Avenues radiate outward from the citadel towards the edge of town. The outer areas of the necropolis are given over to storage areas for mindless creatures and crypts and abodes for minor undead. The ghouls and ghouls dwell within tunnels dug beneath the city.

If the characters wandered into this city, they could disguise themselves as vampires or other undead creatures. The living dead have no innate ability to sense mortals. So long as the characters have convincing disguises, they can move about unmolested. Obviously the mindless undead pay the characters no mind. They are charged with completing manual labor and don't pay much attention to passers-by.

**The Forest:** The bulk of Dreadfall is covered by forests of dead trees. Solitary undead wander these regions, many of whom are exiled from necropolis at the whims of that city's lords or are fugitives who fear destruction at the hands of political rivals. Some are drawn to the heavy concentration of negative energy, while others are belched forth from Aulick's gateway. Allips, bodaks, devourers, and other independent undead creatures wander these areas and prey on all they encounter, including undead travelling to and from the necropolis and Aulick's citadel. The lich lord considers these creatures a worthy test of his minions and delights in unleashing monstrous beings on to the cloud realm. Occasionally, a powerful undead creature gathers together a small horde to assault the necropolis or fortress.

Characters travelling through this area have a high likelihood of encountering dangerous undead creatures. Each hour spent in this region, there is a 50% chance of an encounter with undead whose EL equals 3d6.

In addition to the wandering undead, there are a few areas of interest found within this hell-blasted wilderness. The Skull Shrine is one such structure. It spontaneously arose from the ground as negative energy surged into the prime plane. Aulick watches the place with a keen eye, as he considers its growth to be a key indicator of the progress of his plans. The place started as little more than a shack but now rivals a royal palace in size. Its walls, floors, and ceilings are comprised of human skulls. Its chambers and vaults are mostly empty, though sometimes a group of undead creatures wanders into this place. The shrine's largest, central chamber is a great, vaulted cathedral featuring an altar crafted from crimson stones. This room is tended by a bent, ancient human known as The Bone Keeper (human CE Clr15). This priest's origin is unknown even to Aulick. He simply appeared one day within the shrine and since that day has tended to the place, cleaning the chambers of debris and driving out groups of undead who attempt to lair here. The old man speaks quietly and is personable enough with the living. If questioned of his purpose, he says only that he awaits the new master of creation to claim his palace. When he arrives, The Bone Keeper shall serve as his first and only prophet. Aulick believes that The Bone Keeper is a herald of the end of the world. When the time is right, the lich is to journey to the keep where The Bone Keeper shall declare him the ruler of the cosmos. In truth, The Bone Keeper is a

being created by a powerful god who seeks to use Aulick in his holy war against the gods of good. When Aulick's undead army grows large enough, the god plans to bid The Bone Keeper to deliver false prophecies to Aulick that will lead him to launch a war against the surface world with his undead legions.

**Aulick's Citadel:** This 100-foot tall tower is surrounded by a tall, obsidian wall. A small cloud of ghosts flits about the tower. They are bound to this location by Aulick and are compelled to attack all who approach from above. Aulick's tower is one gigantic focal point for energy from the negative material plane. The inner portion of the tower is in truth one titanic undead creature. The floors, walls, and furniture are all crafted from bones and flesh of the dead. Aulick must merely issue a command and the bones in the floor form a chair for him to sit upon, or the walls reach forth with grasping hands to attack. Staircases suddenly drop away, as the floor below forms a hole that sends an intruder plummeting 100 feet to his death. Aulick (male human lich LE Wiz20) spends his day in the tower's uppermost level, gazing into the infinite darkness of his gate to the negative material plane. This gate forms the tower's roof and jets a steady stream of negative energy into the sky, sustaining the cloud realm's form and giving this region its unique characteristics.

In battle, Aulick commands the tower to drop his opponents to their deaths or claw at them, making 1d4 attacks as per a Medium skeleton against each character per round. In addition, each round the tower generates 1d4 zombies or skeletons of Huge size up to a total of 100 active at any one time.

If the gateway is destroyed, the entire cloud realm begins to disintegrate. The undead creatures living here, save for Aulick, are blasted out of existence by the sudden shock waves of planar energies that seal the breach. Destroying the gate is no trivial task. Spells and items may be tossed into it only from below. The stream of energy pouring from its upper surface knocks aside all spells and other effects. While the exact method for destroying the gate is best left to the details of your campaign, methods include casting the corpse of an arch-devil or demon lord through the gate, cleaving it with a holy blade doused in the life blood of a 20th-level paladin, or sundering it with the weapon of a god.

Aulick is supremely arrogant. His centuries of existence and continued successes have driven him to believe that no mortal is his equal. He delights in slowly defeating the few explorers who venture to his tower and patiently awaits them at its uppermost floor. Those who prove little sport are tossed through the gate as sacrifices, while worthy foes are transformed into undead servitors and dispatched to the necropolis.

Few guards watch this place, though if the undead within the forests become troublesome Aulick sometimes bids a troupe of vampires, ghouls, and zombies to stand watch at the tower's base. These creatures are specifically instructed to let living creatures, who could present some entertainment for the lich, enter the tower unmolested.



# Fulgash's Tower

The archwizard Fulgash faced a simple problem when 10,000 screaming orc barbarians marched upon the civilized lands. As luck would have it, the particular hilltop on which Fulgash chose to erect his tower, the one with the lovely view of a nearby mountain pass and commanding presence over the valley below, was directly in the invading horde's path. Had Fulgash used his magic to scry upon the orc high command's war meetings, he would have seen his particular hill circled in blood with the orcish words for "We take this hill or die trying" scrawled next to it. As Fulgash's luck would have it, he had built his tower not only on a tactically appealing spot but also atop the ancient burial grounds for a monastic order of monk warriors. While Fulgash had found the mob of fearsome orcs who occupied his hill rather bothersome when he first claimed it, the view the hill offered and the basalt tower already standing there made the spot attractive enough for him to blast the orcs with his magic.

Had Fulgash been a diviner, he may have learned that his attack on the orcs caused their shaman to flee to the Wastelands, where he wandered for two years before receiving a vision that led him to unify the tribes and declare a holy war on humanity. But that is neither here nor there. Besides, Fulgash almost welcomed the invasion. It gave him an excuse to activate an ancient artifact he had uncovered, *Aristophocles's wondrous compass*. What powers the compass possessed, none can truly say. The item's history was long forgotten even by the elf sages. What is known is that one night, as the orc hordes appeared over the horizon, Fulgash's tower and the hill it rested upon lurched into the sky. With a tremendous rending, the hill was torn in two and borne aloft into the air by unknown magics.

Two important events immediately followed. Firstly, the tower soared into the air at an angle, sending Fulgash plummeting out a window to his death. Secondly, the flying tower bore a striking resemblance to one in orc legends concerning the appearance of an orc godling and an imminent revolt by a powerful cabal of legendary female orc sorceresses. Thus, the orc horde immediately did an about-face and returned home. Had Fulgash lived through the night, he doubtlessly would have been feted at the king's court rather than been the guest of honor at a conclave of buzzards, field rats, and other scavengers.

While the wizard is long dead, his tower still floats through the sky amongst the cloud realms. Owing to a severe miscalculation in Fulgash's studies of the compass, the tower is permanently cocked at a 45 degree angle relative to the ground. It is now a floating chunk of earth crowned with a black, basalt tower three stories tall. A popular destination for treasure hunters and other adventurers, the tower is said to hold a wealth of gold, gems, and magical items for anyone who can brave its magical traps and peculiar arrangement. It is said that the tower's heavy tilt, rather than its traps and denizens, is responsible for the deaths of most explorers who meet their end there. The popular surface-world legends of heavily armored men falling from the sky support that supposition.

## Special Rules

With its sharp tilt, the tower presents a unique adventuring environment and a host of problems for would-be treasure seekers. The sloping floors must be climbed for a character to cross them. The Climb DC to move along the tilted floors is 0. However, a character moving in this manner suffers some of the penalties for climbing. He suffers no chance of sliding down the slope but moves at half-speed and loses his Dexterity bonus to AC. A character can move, fight, and defend himself as normal along the slope by making a Balance check (DC 15) each round he attempts to do so. On a failed check, the character tumbles down the slope. If his movement sends him towards a door or window, he must make a Climb check to catch himself (DC 10) or tumble through the portal. A character may also opt to make a Climb check (DC 10) at any point in his fall to catch himself on the slope. Upon coming to a halt after tumbling down the slope, a character is considered prone. A character who is paralyzed, held, or otherwise rendered motionless automatically tumbles downward. If such a character could fall through a doorway or window, there is a flat 50% chance he tumbles through.

Creatures bigger than Large cannot fit through doors or windows. Instead, if they fall through they become wedged in the portal and must make a Strength or Escape Artist check (DC 15 for either) to escape. While trapped they lose their Dexterity bonus to AC, have a -4 penalty to Dexterity, and are at -2 to attack rolls.

## Reading the Map

The map of the tower includes an arrow that points in the downward direction of the slope. When a character falls, he tumbles in a straight line in the arrow's direction.

## Map Key

**1. The Gardens:** When Fulgash's tower was still earth-bound, this area was a garden teeming with a wide range of herbs, magically altered plants, and other rare specimens. Fulgash was an amateur botanist who was prompted to build a tower in the wilderness to better study plants and experiment on using magic to alter and control them. The gardens are now an overgrown maze of hedges, brambles, and other thick plants. It is impossible to see more than 10 feet in any direction from ground level. A character who stumbles down this area's slope always stops after falling 10 feet, but there is a 50% chance he crashes into a thorny bush that could tear into him. Make an attack at +5 to hit that deals 1d6 damage against the character. All creatures move at half-speed through this garden. Any creature that moves at a faster rate must make a Reflex save or become entangled in the thick vines and bushes in the garden. A creature trapped in such a manner loses his Dexterity bonus to AC, suffers a -2 penalty to all attacks, and may not move. The creature can free itself by making a Strength or Escape Artist check (DC 15

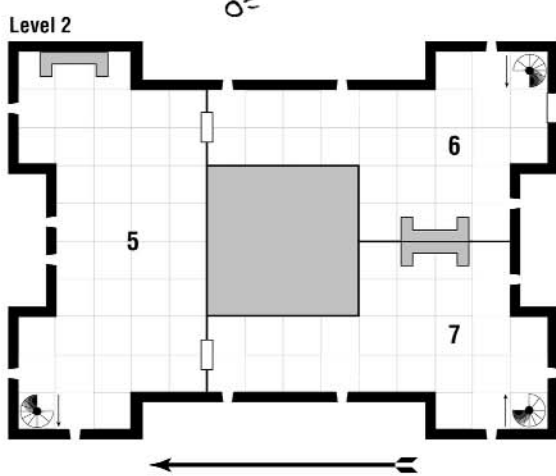
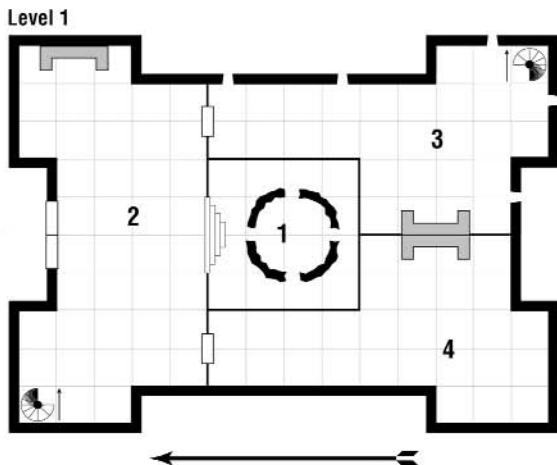
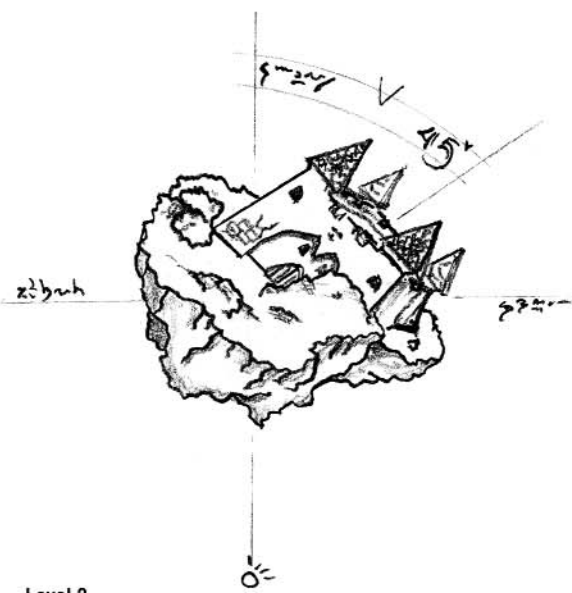
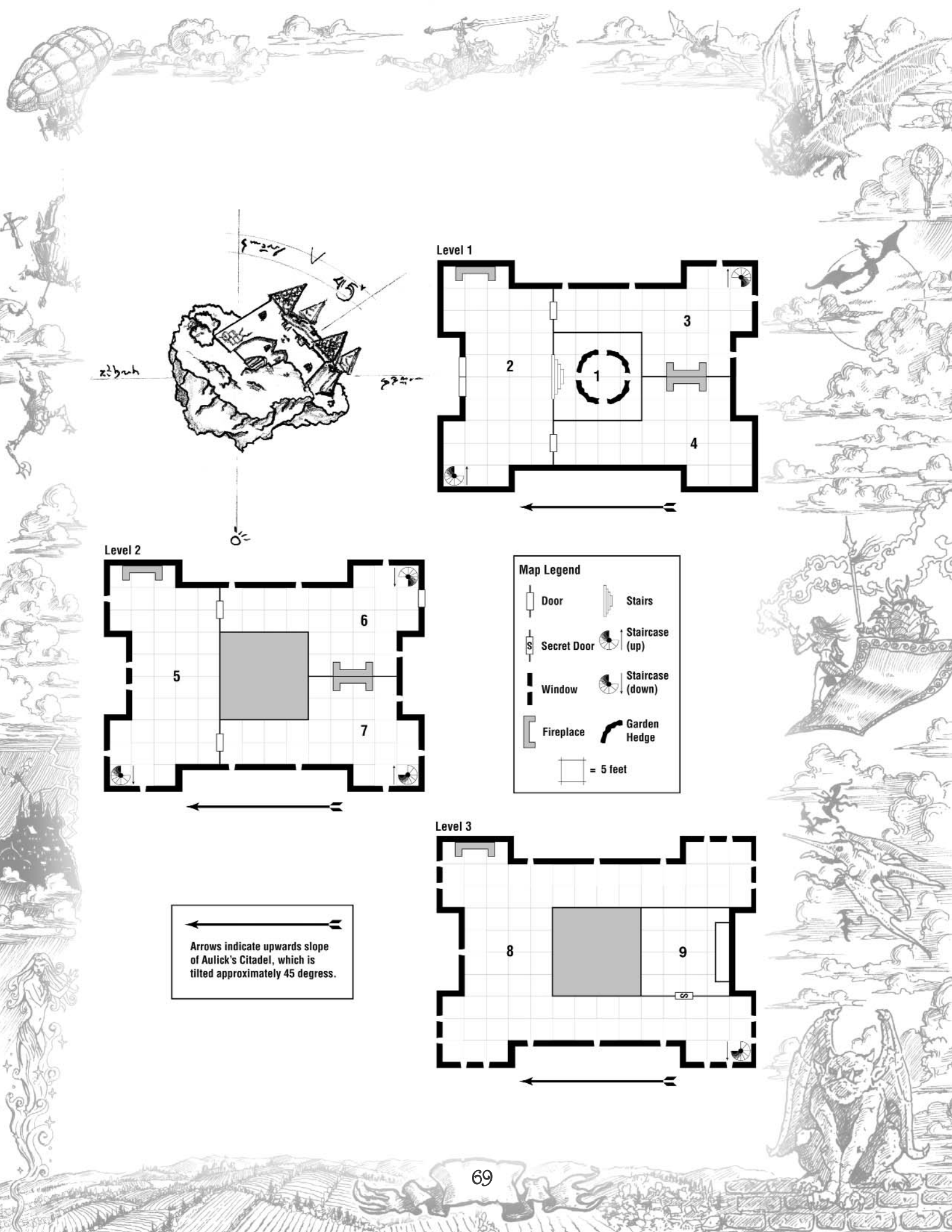

**Map Legend**

	Door		Stairs
	Secret Door		Staircase (up)
	Window		Staircase (down)
	Fireplace		Garden Hedge

= 5 feet

← →  
 Arrows indicate upwards slope of Aulick's Citadel, which is tilted approximately 45 degrees.

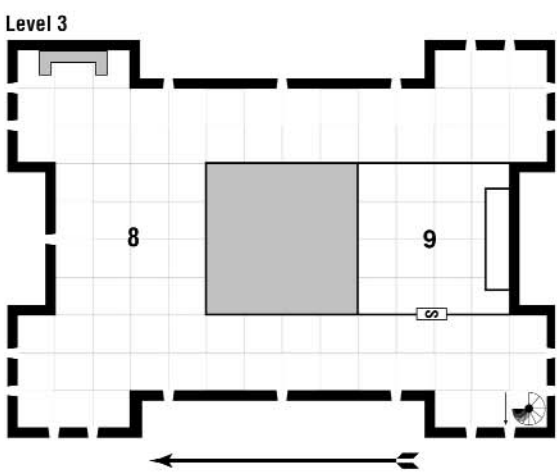



for either).

Common creatures found here can include any flying creature that seeks to prey on creatures trapped in the gardens. Within the gardens, assassin vines (CR 3), shambling mounds (CR 6), and tendriculos (CR 6) are sometimes seen. A will-o'-wisp also haunts the gardens, drawing explorers close to the edge in hopes of luring them to their deaths. Treasure here consists of coins and items found on the tangled remains of previous explorers, treasure buried here by Fulgash or expeditions that planned to return for the loot, and stray items caught in the thick plant growth.



**First Floor:** The rooms here were primarily used to entertain and host guests. Creatures found here could include a nest of harpies who lair here, undead creatures risen from the remains of previous expeditions, and plant creatures such as shambling mounds who claim this place as home. Spiders and flying creatures make good opponents in the tower, as they can ignore the sloped floor and attempt to push characters through windows and out doors.

The entire first floor is choked with dirt and plants from the surrounding garden. The downslope corners of the room are buried in dirt and plants.

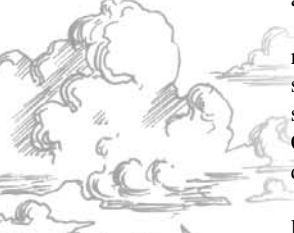

Throughout the tower are several fireplaces and chimneys. Any character with a size of Small or lower can squeeze into a fireplace and climb up the chimney with a successful Escape Artist check (DC 15) and subsequent Climb check (DC 12). A fireplace connects to the ones directly above and below it.

Throughout the tower, the doors and windows have long since been battered to pieces or carted off as loot. Thus, all the doors and windows are wide open.



**2. Entry Chamber/Dining Room:** Long ago, Fulgash used this room to welcome guests. Stone pegs set into the wall once held cloaks and bags. The furniture here long since tumbled out of the tower or was looted by explorers.

**3. Kitchen:** A large table and other debris are piled at the far end of this room, though the windows are still exposed for hapless characters to fall through. The one item still intact here is a large, ceramic basin fixed with an iron spigot. When Fulgash built this place, he designed the spigot to tap into the elemental planes and generate an endless stream of water. Unfortunately time and abuse by visitors have damaged the mechanism. If it is activated, it blasts forth a stream of scalding hot water. Resolve an attack against the character who activated the spigot at a +5 base attack bonus. On a hit, the character takes 1d8 damage and must make a Balance check (DC 20) or be knocked to the ground and slide along the floor.



**4. Guest Room:** This area once served as a bedroom for the tower's visitors. Two crumbling beds are wedged at the bottom of the room's slope, though an armoire bolted to the south wall still stands. The armoire is locked (DC 20 to open) and contains a small treasure cache stored here by a previous group of adventurers, 100 gp in a leather sack and a silver masterwork dagger.



**Second Floor:** This area once served as Fulgash's primary living space. Monsters found here can include creatures encountered on the first floor or perhaps a group of evil adventurers who seek to loot this place. Characters who plummet out a window here fall a total of 20 feet, as the

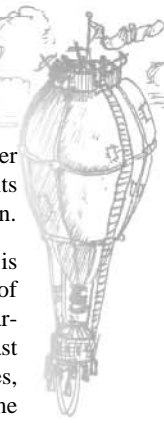

island's tilt makes the fall a bit farther than if a character dropped straight down the tower's side. Once a character hits the ground, he then slides as per falling down in the garden.

**5. Study:** Once Fulgash's inner sanctum, this place is now a garbage strewn mess. For several months a band of evil humanoid mercenaries kept a pair of young trolls quartered here. Thus along the bottom of the slope along the east wall is a layer of dung several inches thick, gnawed bones, and other refuse. In addition, two spigots channel flame energy into this room. At first glance they resemble *continual flame* spells, but in truth they project heat just like open flames. Any character who slides down to the wall in this room must make a Reflex save (DC 15) or suffer 1d4 points of fire damage as he slams into the open flame.

**6. Bedroom:** At one point, this was Fulgash's personal bedroom. As a driven, relentless researcher, he spent little time in here. Its most prominent feature is the doorway set into the eastern wall. This portal once opened on to a small porch Fulgash built on to the side of his tower. However, the porch long since collapsed, leaving the doorway a convenient opening for a monster to push a character through.

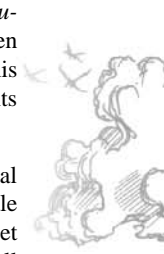

**7. Library:** The most striking feature of this room is a large pile of hacked, stained, and otherwise severely battered books piled at one end. Wooden bookshelves are set along the walls here, their contents now consigned to the pile below. There are two things of interest hidden within this area. The pile of tomes contains one spellbook buried within it (Search DC 20) containing *animate rope*, *rope trick*, and *shocking grasp*. A hidden compartment on the southern bookcase (Search DC 30) hides a ruby worth 300 gp and a scroll of *flame arrow*.

Any character who slides down the floor in this room bounces off the books, causing a flood of them to slide out the window and possibly taking the character with them. Any character who slides towards the far wall must make a saving throw to avoid tumbling out a window whether he slides towards it or not.

**Third Floor:** This area is dominated by a large laboratory and a long-sealed vault that contains some of Fulgash's treasures. While the artifact he used to send this tower aloft is long gone, the wizard's last treasure cache awaits adventurers talented and brave enough to claim it from its guardian.

**8. Lab:** While this area was once stocked with magical items, expertly-crafted alchemical tools and glassware, and other tools found in a well stocked wizard's lab, it is now utterly bare. Over the years, explorers and adventurers have thoroughly ransacked this place. Most of the glassware once found here has ended up in shards at the bottom of the room's slope. Any character who slides down the floor must make a Reflex save (DC 15) or take 2d4 points of damage by falling into a pile of jagged, broken glass.



**9. The Vault:** The secret door marked on the map is rather easy to spot. The section of wall it occupies has been cleaned of dust, marked in chalk, chipped with hammers, and otherwise damaged by previous visitors. A secret catch on the opposite wall opens the door. Finding the catch requires a DC 25 Search check.

Within this room is the last of Fulgash's once consider-



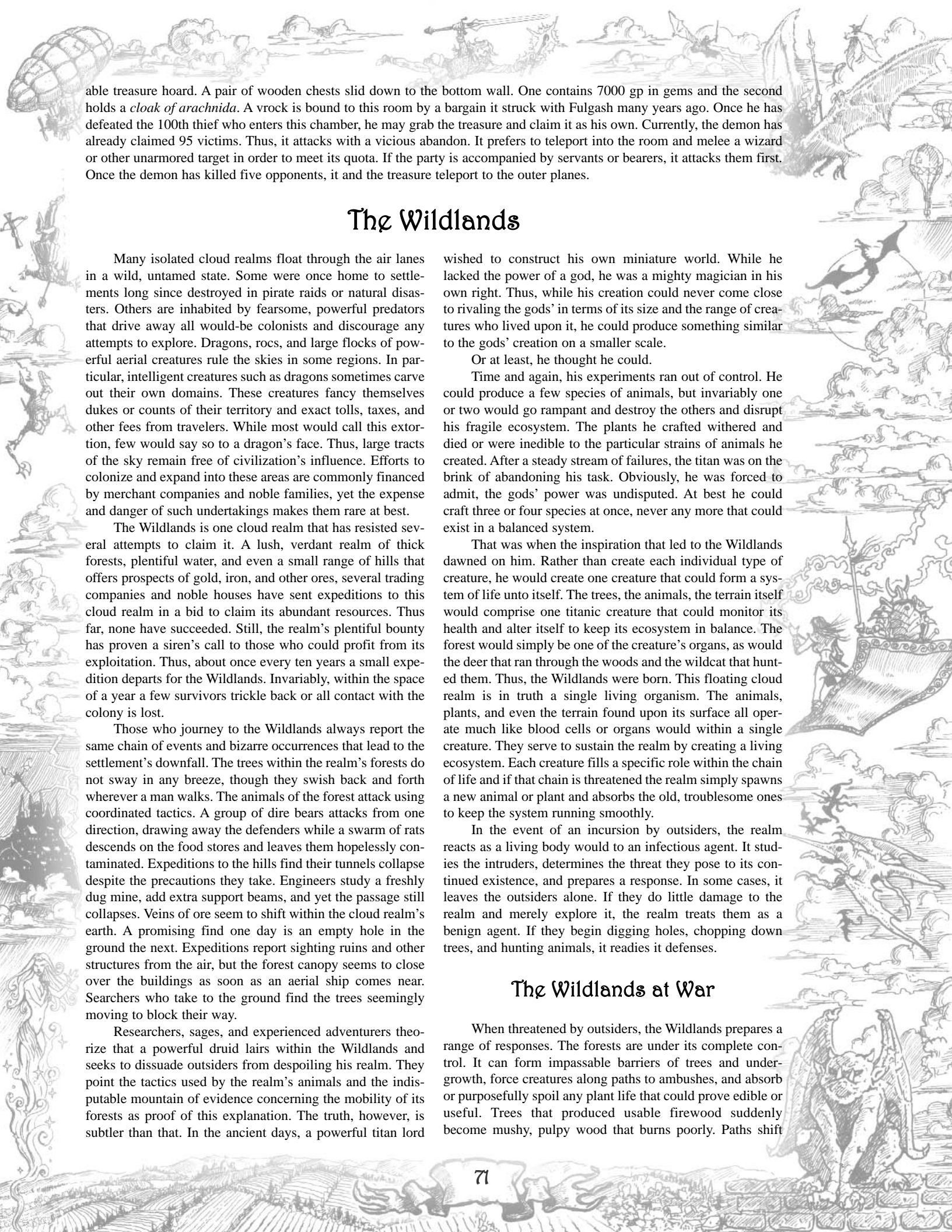

able treasure hoard. A pair of wooden chests slid down to the bottom wall. One contains 7000 gp in gems and the second holds a *cloak of arachnida*. A vrock is bound to this room by a bargain it struck with Fulgash many years ago. Once he has defeated the 100th thief who enters this chamber, he may grab the treasure and claim it as his own. Currently, the demon has already claimed 95 victims. Thus, it attacks with a vicious abandon. It prefers to teleport into the room and melee a wizard or other unarmored target in order to meet its quota. If the party is accompanied by servants or bearers, it attacks them first. Once the demon has killed five opponents, it and the treasure teleport to the outer planes.

## The Wildlands

Many isolated cloud realms float through the air lanes in a wild, untamed state. Some were once home to settlements long since destroyed in pirate raids or natural disasters. Others are inhabited by fearsome, powerful predators that drive away all would-be colonists and discourage any attempts to explore. Dragons, rocs, and large flocks of powerful aerial creatures rule the skies in some regions. In particular, intelligent creatures such as dragons sometimes carve out their own domains. These creatures fancy themselves dukes or counts of their territory and exact tolls, taxes, and other fees from travelers. While most would call this extortion, few would say so to a dragon's face. Thus, large tracts of the sky remain free of civilization's influence. Efforts to colonize and expand into these areas are commonly financed by merchant companies and noble families, yet the expense and danger of such undertakings makes them rare at best.

The Wildlands is one cloud realm that has resisted several attempts to claim it. A lush, verdant realm of thick forests, plentiful water, and even a small range of hills that offers prospects of gold, iron, and other ores, several trading companies and noble houses have sent expeditions to this cloud realm in a bid to claim its abundant resources. Thus far, none have succeeded. Still, the realm's plentiful bounty has proven a siren's call to those who could profit from its exploitation. Thus, about once every ten years a small expedition departs for the Wildlands. Invariably, within the space of a year a few survivors trickle back or all contact with the colony is lost.

Those who journey to the Wildlands always report the same chain of events and bizarre occurrences that lead to the settlement's downfall. The trees within the realm's forests do not sway in any breeze, though they swish back and forth wherever a man walks. The animals of the forest attack using coordinated tactics. A group of dire bears attacks from one direction, drawing away the defenders while a swarm of rats descends on the food stores and leaves them hopelessly contaminated. Expeditions to the hills find their tunnels collapse despite the precautions they take. Engineers study a freshly dug mine, add extra support beams, and yet the passage still collapses. Veins of ore seem to shift within the cloud realm's earth. A promising find one day is an empty hole in the ground the next. Expeditions report sighting ruins and other structures from the air, but the forest canopy seems to close over the buildings as soon as an aerial ship comes near. Searchers who take to the ground find the trees seemingly moving to block their way.

Researchers, sages, and experienced adventurers theorize that a powerful druid lairs within the Wildlands and seeks to dissuade outsiders from despoiling his realm. They point the tactics used by the realm's animals and the indisputable mountain of evidence concerning the mobility of its forests as proof of this explanation. The truth, however, is subtler than that. In the ancient days, a powerful titan lord

wished to construct his own miniature world. While he lacked the power of a god, he was a mighty magician in his own right. Thus, while his creation could never come close to rivaling the gods' in terms of its size and the range of creatures who lived upon it, he could produce something similar to the gods' creation on a smaller scale.

Or at least, he thought he could.

Time and again, his experiments ran out of control. He could produce a few species of animals, but invariably one or two would go rampant and destroy the others and disrupt his fragile ecosystem. The plants he crafted withered and died or were inedible to the particular strains of animals he created. After a steady stream of failures, the titan was on the brink of abandoning his task. Obviously, he was forced to admit, the gods' power was undisputed. At best he could craft three or four species at once, never any more that could exist in a balanced system.

That was when the inspiration that led to the Wildlands dawned on him. Rather than create each individual type of creature, he would create one creature that could form a system of life unto itself. The trees, the animals, the terrain itself would comprise one titanic creature that could monitor its health and alter itself to keep its ecosystem in balance. The forest would simply be one of the creature's organs, as would the deer that ran through the woods and the wildcat that hunted them. Thus, the Wildlands were born. This floating cloud realm is in truth a single living organism. The animals, plants, and even the terrain found upon its surface all operate much like blood cells or organs would within a single creature. They serve to sustain the realm by creating a living ecosystem. Each creature fills a specific role within the chain of life and if that chain is threatened the realm simply spawns a new animal or plant and absorbs the old, troublesome ones to keep the system running smoothly.

In the event of an incursion by outsiders, the realm reacts as a living body would to an infectious agent. It studies the intruders, determines the threat they pose to its continued existence, and prepares a response. In some cases, it leaves the outsiders alone. If they do little damage to the realm and merely explore it, the realm treats them as a benign agent. If they begin digging holes, chopping down trees, and hunting animals, it readies its defenses.

## The Wildlands at War

When threatened by outsiders, the Wildlands prepares a range of responses. The forests are under its complete control. It can form impassable barriers of trees and undergrowth, force creatures along paths to ambushes, and absorb or purposefully spoil any plant life that could prove edible or useful. Trees that produced usable firewood suddenly become mushy, pulpy wood that burns poorly. Paths shift



and bend to confuse travelers and lead them in endless circles. The canopy overhead thickens and blots out the sky.

Meanwhile, the realm goes to work organizing its animal life to respond to the threat. The realm can produce any sort of dire animal, normal animal, or vermin it needs to repel attackers. However, creating such creatures takes time and energy. Once per day, the realm can launch an attack against intruders. As a rule of thumb, the animals who comprise the attacking force should have an EL one or two above the party's average level. The animals attack with a supreme level of coordination. They strike from multiple sides at once or use diversions to draw guards away from their true targets. As the entire realm is one self-aware creature all animals produced by it gain a +8 competence bonus to Listen and Spot checks. Small animals use the aid another combat action to help their larger brethren, while the animals work together and willingly lay down their lives to take down the enemy one by one.

When an animal or plant is killed, its corpse melts into the cloud realm's surface within 2d6 minutes. All the living things found in the Wildlands taste terrible and are wholly inedible. When a creature is slain, its internal organs and muscles immediately begin to transform back into the protoplasmic goo that spawned them.

Air ships or other craft and creatures that fly above the Wildlands may come under attack from the trees below. The forest generates vines that reach out to grapple and drag ships down to the surface. Resolve this as a grapple attack made by a creature with a +10 base attack bonus and a 22 Strength. After dragging a victim down to the forest floor, the realm sends its animals in to finish them off.

Invading creatures killed in battle are absorbed into the ground and devoured by the realm 2d4 rounds after falling. It takes 4 rounds for a creature to be dragged below the surface and slowly drained of blood and other fluids. A character trying to save a comrade from this fate must make a Strength check (DC 20) to pull him free.

The central, hilly area is even more dangerous than the forest. Tunnels and old mines honeycomb this region. While the tunnels appear safe, the realm has the same ability to alter, distort, and collapse such tunnels as it can modify the animals and plants of its forests. The Wildlands shifts tunnels and blocks off exit routes in order to starve and eventually absorb explorers. It may attempt to crush characters within its tunnels by slamming the walls shut around them. A character must make a Reflex save (DC 15) to avoid being caught between two walls. Those who fail take 2d6 crushing damage.

## Triggering an Attack

The Wildlands is an incredibly efficient creature. It can survive almost exclusively on the nutrients synthesized by its plants. The trees and other plants it creates draw sustenance from the rain and sun, helping to provide nutrients and energy to the entire system. Thus, it normally attacks visitors only if provoked. Anyone who digs into its surface, chops through its trees, attacks or hunts its wildlife, or seeks to build large, permanent structures draws its ire. Otherwise, the realm is content to leave visitors in peace. Regrettably, those who come here invariably break those strictures as they seek to establish a colony or carry off the realm's resources.

## The Wildlands: A Gazetteer

Characters can journey to the Wildlands for a number of reasons. They could be sent here to determine the fate of the latest lost expedition, they might come in search of treasure or an artifact rumored to be lost here, or simple curiosity could prompt them to explore the region in hopes of discovering its secrets. The stone ruins sighted within its forests continue to intrigue sages, as explorers have yet to uncover their location or explore their depths and live to tell the tale.

### The Forest

This dense, thickly forested area is the home to a wide range of plants and animals. Any character with Knowledge (nature) can determine (DC 15) that the mix of plants and animals is somewhat wrong for the climactic conditions in the area. The occasional palm tree stands amongst pines while tropical animals run with ones from temperate areas. Since all the animals and plants are generated by the realm, their outward appearance bears no connection to their inner workings. The thing simply creates life that looks appealing and was described to it by its creator.

Scattered within the forest are stone plinths that show signs of arcane runes long since worn down to unrecognizable scribbles; simple, dome-shaped stone structures made of loose rocks and mud; and a two story stone building carved from a single block of obsidian. These monuments all serve as foci for the realm's life energy. They form a magical pattern that holds the Wildland's ecosystem in balance and allows it to display its unique characteristics. The realm works hard to change forest paths, alter the landscape, and otherwise make it extremely difficult to uncover these sites.

The plinths are each always guarded by three dire bears. The bears are immune to all mind-influencing spells and fight to the death to protect their charge. There are a total of 100 plinths in the Wildlands. If more than half are toppled, the entire cloud realm slowly disintegrates, disappearing completely in one year.

The sentience within the Wildlands works to fix any toppled plinths, dispatching animals to restore them. The small rock structures are breeding vats for new animals and plants. They house a deep pool of red, viscous proto-organic matter that gives birth to the creatures the realm requires to defend itself and maintain its ecosystem.

The large, obsidian temple is perhaps the most important single structure in the Wildlands. Though it has little bearing on the realm's continued existence, it reveals the mystery of its past. The structure has two levels above ground that house an ancient library, the living quarters of the titan who once dwelled here, and an arcane laboratory. The titan, a powerful magician and sage named Thendenis, has long since abandoned this project but his legacy remains here. The entire structure is designed for a 25-foot tall being, including the doorways, ceilings, and furnishings and other features. A squad of stone golems currently patrols the grounds, seeking to peacefully lead intruders away and only resorting to violence if attacked. A total of a dozen golems wander the upper two levels. While Thendenis carried away most of his valuable treasures, a few baubles remain. This place has gone undisturbed for eons, and the next group of explorers to discover it shall be the first.

The first level consists of meeting rooms, a laboratory, and a library. While the books stored there have long since decayed, a collection of stone tablets details the basic background of this place. More importantly, it describes the presence of three dungeon levels beneath the obsidian fortress. There, at the bottommost level, stands the control room for the entire realm. Any character who spends a month studying these tablets and makes an Intelligence check (DC 20) can learn how to control and command the entire cloud realm. A character who fails this check may study the tablets for an additional week and make another check, repeating this process until he gives up or makes the check.

The first dungeon level is hidden behind a secret door in the laboratory. While finding the door is rather easy for an experienced character (Search DC 20) the searcher must be ten feet off the ground in order to have any chance of noting the hidden lever that opens the door. This first level consists of chambers dedicated to the research and creation of new life forms. This is where Thendenis investigated the possibility of creating new creatures from their component parts and eventually developed much of the theory he needed to complete the Wildlands. This area is guarded by more stone golems and many traps. A few bizarre, failed experimental creatures are kept in stasis and may be unleashed by unwitting characters. Aberrations may be encountered in this manner.

The second dungeon level was given over to the research of plant life. The entire level is overgrown with a thick layer of a bizarre, mutated combination of fungus and plant life. The floors, walls, and ceilings are covered in a murky gray layer of this lifeform. As the characters walk across it, it pulses with life and calls to its children to deal with the intruders. In many ways, this creature is the forerunner of the sentience that controls the Wildlands. The lifeform commands plant and fungus creatures including shambling mounds, tendriculoses, violet fungi, and even a small tribe of degenerate, half-fungus treants. These creatures worship the colony like a god and obey its mental commands. They believe that the world outside of their dungeon level is infested with horrid rock monsters (actually the golems who police the level above) and consider themselves the last living creatures in the cosmos. If the characters approach these creatures with peaceful intent, they can convince them to hold off their attack and listen to their tale. If the PCs admit to defeating any golems, they are met with friendship. The colony wishes only to be left alone and perhaps to dispatch one of its followers with the PCs to explore the world above.

The final dungeon level is accessible through a pool of water that stands within the treant creatures' lair. The final level is completely flooded with water, save for the control room located on the far end from the entrance. Once, Thendenis researched ocean life in part of this level. To foil explorers and thieves, he flooded the entire level and bid the sentience that controls the Wildlands to spawn dire sharks to watch over this place.

When the characters finally arrive at the control room, they find it a simple throne with a steel crown resting upon it. Anyone who sits on the throne, dons the crown, and has read and understood the stone tablets from the obsidian structure gains the following powers:

- The sentient spirit of the Wildlands obeys his commands. It does not attack or harm anyone marked as a friend by the controller.

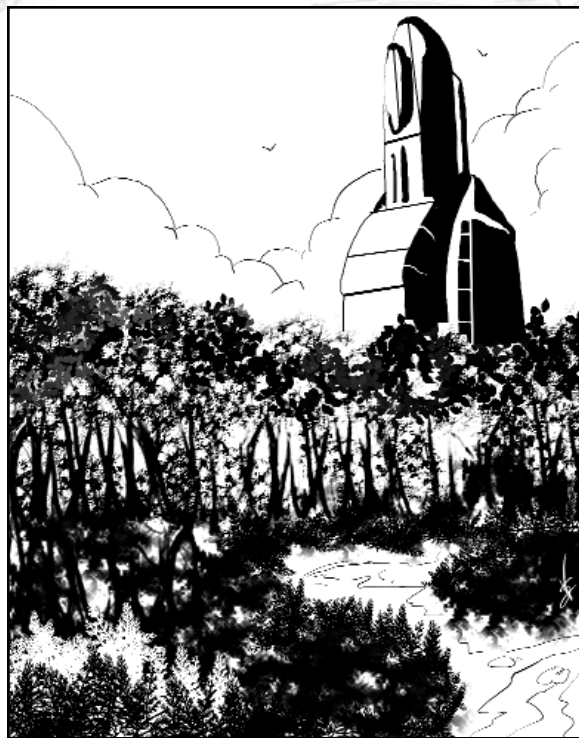

- The controller may now command the plants and animals that are spawned by the Wildlands. He may generate 50 hit dice of animals each day and may keep a total of 500 hit dice worth on the island. These creatures may leave the Wildlands but shrivel and die within 2d4 days unless they return home. They obey the controller's orders to the best of their ability. These orders are issued mentally via the throne and crown.
- The controller gains omniscience within the Wildlands. So long as he sits upon the throne and wears the steel crown, he sees all and hears all that takes place within his realm.
- The controller may order the entire cloud realm to move. It may travel up to 20 miles per hour and ignores all weather conditions.
- The sentient intelligence recognizes the last person to wear the crown and sit upon the throne as the ruler of the Wildlands. It obeys his verbal orders and carries out tasks he appoints after he leaves the throne. However, should someone else take command that person becomes the new master. The Wildlands' sentience allows it to hear and obey its master, so long as he remains on the cloud realm. Should he leave and return, it continues to obey him so long as no one else has claimed his position.

The throne is sized for a titan, as is the crown. When a creature touches the crown, it immediately changes shape to fit the creature bearing it. The crown may never leave the control room, despite whatever magical or physical efforts are undertaken to carry it away. The two are intrinsically bound and may not be separated. The crown immediately vanishes and reappears on the throne if someone attempts to make off with it.

Obviously, the throne and crown are powerful artifacts. In the characters' hands, the Wildlands can quickly become their base of operations and personal fortress. Of course,





when news of this development spreads many of their rivals, enemies, and other opponents may try to take the realm for their own.

## The Hills



The realm's central region is marked by a series of high, steep hills that bear only scattered patches of forest. Any dwarf, gnome, or character with the Profession (miner) skill can determine with a Profession (miner) skill check or an Intelligence check (DC 15) that the dirt and soil found on the hills seems somewhat odd. The grain, texture, and color do not quite match what one would expect for exposed, hilly terrain. As with the animals and plants found here, the hills are simply a construct grown by the realm to serve its needs. In this case, the hills are an attractive roosting spot for birds and other creatures that the realm absorbs and devours.



The mines within the hills invariably find little ore of use. While some steel and gold veins exist within them, the Wildlands shifts them away if they are exposed and works to protect them from prospectors. Any metals found here are simply a byproduct of the magic used to form this cloud realm. No more than 5000 gp worth of ore is available here if the characters were to extract it, such as by seizing control of the realm and mining its hills.

## Ruined Colonies



These sites were once small settlements established as beachheads for later, larger scale attempts to colonize the realm. Obviously, none succeeded. These areas are extremely overgrown with grass, underbrush, and in some cases small trees. The remains of any cabins, walls, or other traces of structures are faint at best. Anyone with the Survival skill who knows how long ago the ruins were built can determine with a successful check (DC 20) that the ruins are far too overgrown with forest plants in the time since they were first built. Trees grow from the midst of ruined buildings and wooden walls are far too rotted considering the time period that has passed.



The foremost ruined colony, and the one most often mentioned in stories of the Wildlands, is great fortress known as the old stone fort. According to legend, a powerful elf wizard named Palantheo was drawn to the stories of the Wildlands and sought to answer its riddles for himself. Using his magic, he erected a fortress of stone near the edge of the cloud realm's boundaries. Many believed that this fort represented the best chance of establishing a successful, long-term foothold on the sky realm. For the first year, the fortress sur-

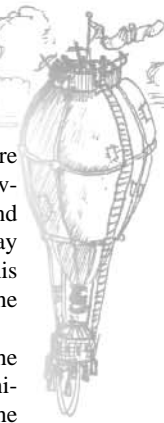

vived intact. Palantheo ordered his men to never venture more than a hundred feet from the fort's walls. Using his divination magics, he sought to discover the realm's secrets and use them to claim it as his personal domain. For day after day and night after night the elf worked in his study, bent over his tomes of magic and casting his spells to uncover the domain's secrets.

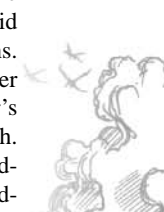

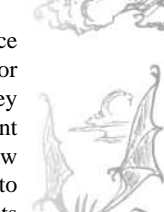

Unfortunately for Palantheo, he never realized the realm's true nature. While he witnessed the spawning of animals that should not be found in an aerial realm and the plants' odd behavior, he attributed this to influence of a druid or a powerful faerie creature that could evade his divinations. He never once suspected that he was viewing the true master of the domain all along merely by looking out his tower's window. For a year, Palantheo continued his fruitless search. He scoured his collection of folios and codices, corresponded at length with other mages of his order, and finally decided to abandon his quest.

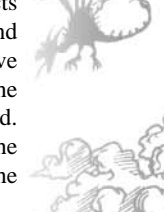

The mercenaries who accompanied him had long since despaired of ever uncovering gold in the realm's hills or claiming the place as their own. With each passing day they grew more and more frustrated that their master was content to sit within his tower and spend his days in what they saw as wasteful study. Thus, when it came time for Palantheo to take his leave and pay off the last of his servants' contracts he offered them a bargain: either receive their full pay and passage back to the nearest civilized cloud realm or receive an equal share of ownership of the stone fort. Many of the mercenaries accepted shares of the fort and remained behind. Soon after Palantheo and his retainers left the Wildlands, the mercenaries who remained behind ventured out into the forests, drew the land's ire, and were killed.



To this day, popular legend holds that Palantheo's fort is a cursed place. The rumors have it that the elf fled after unleashing dark magics that tainted the very rock of the fort. The poor mercenaries he left behind were abandoned there to die at the hands of some fearsome undead monstrosity. Palantheo and many of his loyal followers have since journeyed to parts unknown, allowing this rumor to run rampant. In truth, the stone fort is one of the few secure locations in the Wildlands. The fortress's stone walls and central tower are built atop a large rock slab created by Palantheo's magic. Thus, the realm's plants cannot grow there. The high walls and iron gate are more than adequate to repel most animals the Wildlands can create. Most importantly, those who stay within the fort remain out of the Wildland's baleful eye. As plants cannot grow there, the thing cannot normally watch over those within the fort. Lately, though, the cloud realm has extended vines and plants across the stone slab in an effort to reclaim the place.

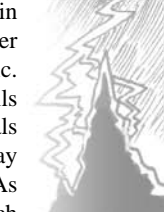
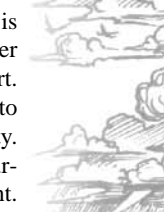



# The Derelicts

From a distance, a derelict looks like a small swarm of objects and creatures or perhaps a small cloud of debris surrounding a single, floating rock. As the characters draw closer, the derelict comes into view in all its alien glory. Some sages theorize that this object is a craft from another world, while others believe it is one of the last remnants of an ancient civilization that dominated the sky before the coming of the gods and the rise of man. Regardless of its origin, the derelict and its cousins (for there are said to be at least a dozen objects similar to it scattered through the sky) bear several basic characteristics.

The derelict is encased within a transparent sphere of energy. When sunlight or other illumination strikes it at just the right angle, the bubble is barely visible as a shimmering field. Within the field, objects float seemingly without weight. Creatures within this field can move by focusing on a point in the distance and concentrating. They then move at a speed equal to their Intelligence score in feet as a standard movement action. Running is impossible in this environment. You cannot “think really hard” in order to move faster.

Creatures crossing through the energy bubble must strain against the field in order to move through it. Piercing the barrier is a standard action. A character cannot be pushed through the bubble with the bull rush action, nor can a character inadvertently move through it. For example, you could not focus on a point outside of the bubble and move through it without bumping into the bubble’s wall.

The air within the bubble is always fresh and warm as a spring day. Wind, rain, and clouds never seem to penetrate its surface. Thus, the bubble is a handy rest stop during a storm or wind squall. It seems as if it would be a good spot for a settlement, trading post, or other sanctuary. However, the nature of the derelict that rests within the bubble, and its strange inhabitants, make that an unlikely prospect.

Inside each bubble is a derelict that appears as a cube-shaped vessel 60 feet on each side forged from an unknown blue metal. All of them show signs of severe damage, such as holes punched in their sides, cracks down each face of the cube, and a small cloud of shattered metal and debris floating around it. In some cases, the cube is ripped in two, revealing its inner structure.

The cubes are set with a single door in the center of each of their six faces. Within its structure are six decks, each 10 feet tall and consisting of a series of square rooms. Most of the derelicts are arranged with four 20 ft.-by-20 ft. rooms in each corner and two 20-ft. wide corridors forming a cross between the rooms. Holes in the floor and ceiling at the corridors or rooms at each level allow visitors to move between the cube’s floors.

A character using *detect magic* detects massive amounts of transmutation magic throughout the cube and the area encompassed by its bubble of energy. Sages theorize that the derelicts were once used as gateways to other realms or as part of some sort of transportation system. When a character

moves into cube, he inadvertently activates several of its powers. First, a character moving through the cube must make a Survival check (DC 25) each minute or lose track of his current orientation. Without a rope or other guide, you should alter the direction that character believes is up, down, right, or left relative to his point of entry. Compounding matters, from the interior of the cube the doorways leading out appear as blue, opaque barriers that blend into the walls. A character seeking an exit must make a Search check (DC 20) to find one. The bottom level of the cube has a gate in the floor of that opens into the ceiling of the top level, making it appear as if a character climbing through the cube’s floor is actually moving into a level below his current one. Some explorers waste hours exploring the same levels of the cube over and over again.

The cubes contain strange items and features built into their floor and walls. Some appear to be cauldrons or pots covered with metallic lids. When opened, they sometimes contain treasure. Other times, strange monsters such as gibbering mouthers, chokers, and shadows lurk within these things. Large containers hold much larger monsters, and on at least one occasion a group of explorers uncovered a chuul. The monsters are invariably dazed for a round or two when they first emerge from these containers and may take no actions. Often, the creatures free themselves and wander the cube looking for a meal. The treasures the containers hold are invariably lumps of valuable material, such as oddly shaped pieces of jade, platinum, or gold. Other times, these urns contain clear water, dirt, mundane plants, and other utterly normal items.

Some of these chambers serve as teleportation chambers that lead to the surface. Many of these are one-way mechanisms that leave the traveler stranded. Most of the creatures spawned within a derelict eventually leave the structure through one of these teleportation devices.

In truth, the derelicts are relics from the ancient past when the gods first formed the world. These items served as gateways and conduits for the divine energy that formed the world and gave birth to many of the creatures that live within it. Long since forgotten by the gods, these things now slowly crumble into ruin. They still spit forth water, plants, precious metals, and other items. The creatures they create are strange, twisted mutants and undead. The magical energies that power the derelicts have begun to fail, leaving them capable of producing only twisted versions of life. In game terms, they create aberrations and undead creatures.

In addition to the strange monsters found within the cubes, pirates and bandits sometimes lurk within them. Those willing to cope with the occasionally rampaging monster can make a derelict a comfortable home. Adventurers are drawn to these things like flies, seeking the treasures they hold both in their strange cauldrons and what is carried on the remains of less fortunate explorers.

## Captain Lebeyewn Of *The Quest*

Captain Lebeyewn is the captain of *The Quest*, the most famous trading ship of the known skies. Lebeyewn has been prowling the sky lanes for as long as most elves can remember, raising questions of how someone who looks human could possibly live so long. The captain answers these concerns with claims of a half-elf heritage, though his only anatomical similarity to an elf is his slight build. This only heightens interest in him, which he welcomes.

Captain Lebeyewn is a smuggler, but of a most curious kind. He is perfectly open about his profession, and invites inquiries concerning his services. He accomplishes his smuggling not via the traditional techniques of stealth and speed, but instead through sheer, unabashed charisma. He is without a doubt the most charming person that your characters will ever meet, and not in an obvious way. He's rather quiet, and a bit on the reserved side. Yet he has a magnetic presence and a wit whose brevity is matched only by its insight. He manages to flatter in the most sincere and unexpected ways, and though he speaks few words, he is never at a loss for the right ones.

He accomplishes his smuggling by forging lifelong relationships with well-placed people in every culture he visits. It is rumored he supplements these relationships with healthy bribes disguised as gifts. Almost wherever he goes, he is greeted by the aristocracy, who host him and sometimes even his crew. No customs bureaucrat or captain of the guard has the temerity to challenge Lebeyewn's cargo manifests when he is met by the nobility, and Lebeyewn himself has the good sense to keep his smuggling limited to those goods that don't threaten his friends and allies. Most of his "imports" are luxury goods banned for political reasons rather than any sort of threat. For example, he routinely smuggles arachial spidersilk into Sellaine, which he trades for sky elf wine that is promptly brought back to the arachials. His cordial contacts extend into all societies, and he is welcomed by the arachial, orcs, and avians just as warmly as by the sky elves. It is rumored he is also on friendly terms with several well-known sky pirates, who use his services to fence their stolen goods, but this is one of the few facts Lebeyewn denies. Wherever he happens to be, Lebeyewn readily owns up to the fact that he smuggles goods into *other* ports, but always insists that his deliveries into this port are completely legitimate – and most of them are, since at least 75% of his cargo is straightforward commercial deliveries. The rest, however, is contraband.

The captain's ship is a *The Quest*, a Scow worthy of note precisely because almost no aspect of it is worthy of note. Unlike most Scow, it is equipped with weaponry, but other than that it is completely standard. There are no secret compartments and no smugglers' holds. Captain Lebeyewn's forthrightness extends so far as to store his cargo in plain sight, and he relies entirely on his good charm to avoid trou-

ble. He also relies on the same charm to keep out of the way of raiders and pirates, and so far he's managed to do so quite well. Over the years, *The Quest* has had a run-in or two with aggressive air monsters of the unintelligent variety, but there has never been a report of it being attacked by any creature of any intelligence. Captain Lebeyewn's personal relationships with those who would normally raid ships like his keep him safe, and those few raiders he doesn't know by name usually end up talked out of their assault, often becoming Lebeyewn's customers before too long. No weapon can defeat his silver tongue.

**Captain Lebeyewn, Half-Elf Exp5 (Sky Sailor)/Bard5:** CR 9; Medium humanoid (5'0" tall); HD 10d6; hp 52; Init +0; Spd. 30 ft., fly 60 ft. (good) (3/day, 5 min. each time); AC 14 (+2 leather armor, +2 ring of protection +2), touch 12, FF 14; BAB +6; Grp +6; Atk +2 rapier +8 melee (1d6+2/18-20) or +1 longbow +7 ranged (1d8+1/x3); Full Atk +2 rapier +8/+3 melee (1d6+2/18-20) or +1 longbow +7/+2 ranged (1d8+1/x3); SQ Half-elf traits, bardic music, bardic knowledge, countersong, fascinate, inspire courage +1, inspire competence, spells; AL CN; SV Fort +2, Ref +5, Will +11; Str 10, Dex 11, Con 11, Int 14, Wis 16, Cha 22 (base 20).

**Skills and Feats:** Balance +8, Bluff +14, Climb +4 (+6 to climb ropes), Diplomacy +30, Gather Information +23, Knowledge (local) +10, Listen +12, Perform +14, Profession (sky sailor) +14, Search +4, Sense Motive +13, Spot +12, Use Rope +5; Leadership (base leadership score 16), Negotiator, Skill Focus (Diplomacy), Skill Focus (Profession [sky sailor]).

**Possessions:** Leather armor, +2 rapier, +1 longbow, 40 arrows, winged boots, ring of protection +2, cloak of charisma +2, 75 pp and 25 gp

**Spells Known** (cast 3/5/2; save DC 15 + spell level): 0-daze, detect magic, know direction, light, mending, message; 1st-charm person, cure light wounds, feather fall, undetectable alignment; 2nd-calm emotion, eagle's splendor, suggestion.

**SA-Half Elf Traits (Ex):** Captain Lebeyewn is a half-elf of an unusual breed. He looks like a normal human, albeit a bit on the petite side. Yet he retains all the normal benefits of his half-elf heritage, as well as a lifespan as long as that of a normal elf.

**The Quest, modified Scow:** Huge Sky Ship; HD 35; hp 192; AC 3 (ship -5, size -2); Hardness 5; Speed 80 ft.; Maneuver Clumsy; Crew 100; Dimensions 40 ft. by 120 ft., 4 decks; Cargo 25 tons; Weapons 4 ballistae (2 forward arc, 2 rear arc), 2 heavy catapults (1 forward arc, 1 rear arc), ramming attack (16d8 damage); Market price 82,000 gp.



## The Sage of Air

In certain regions of the air lanes, sky captains and other travelers have learned the hard way to avoid a small funnel cloud that flits about in seemingly random directions. They have no fear of the cloud's winds, nor do they consider it a true threat to their safety. Rather, they merely wish to avoid a long, boring, drawn-out conversation with Whnlyn, a greater air elemental sage who journeys the prime plane in search of knowledge. Whnlyn uses a magical gate within his airy tower on his home plane to temporarily cast himself into the prime plane. Once there, he hunts down the plane's inhabitants and grills them relentlessly on their habits, beliefs, physical attributes, and so forth.

Whnlyn's mission would not be so bothersome had he a more personable, agreeable personality. Unfortunately, he is impatient, demanding, and petulant. He has been known to halt travelers for several hours and demand they answer his questions in detail, even if they have pressing business elsewhere. Rumors abound of a merchant ship pursued by pirates and dragged to a halt by the air elemental sage so he could question the captain as to why he was trying so hard to evade his pursuers. Left dissatisfied by the frantic merchant's answer, he dragged the ship over to the pirate flotilla and tried to question both groups at once.

Needless to say, once Whnlyn went on his way and left the merchant ship surrounded by corsairs, the poor trader was sacked and left utterly penniless.

Whnlyn is often left dumbfounded and confused by his subject's reactions. Most likely, his treatise will deal with the apparent madness and stupidity of humanoid creatures. He honestly has no idea that his inquiries are bothersome and is shockingly ignorant of humanoid culture. He speaks in a hurried, rapid pace that causes his words to run together in continuous sentences, which only helps cause more frustration for his victims. At his heart, Whnlyn is merely a curious investigator. If attacked he flees in terror. Luckily for him, thus far he has yet to meet a traveler bearing a magical weapon capable of harming him.

Whnlyn makes a good tool to delay or bother the characters when they must deal with a time-sensitive issue. The air elemental simply wants answers to his questions. Since he knows so little of the world, he eats up nonsensical responses and has no idea if the characters lie to him. However, he can prove helpful to clever characters. For instance, if told that a particular ship or person has the answers he seeks, Whnlyn leaps at the chance to track down a promising lead. Smart characters can set him against their rivals using this method. Whnlyn can also make a good continuing nuisance, particularly if he takes a shine to the PCs or considers them fascinating subjects. In this case, the elemental also makes a good font of information. In his travels, he has visited many sky realms and learned many secrets long thought lost. Patient characters should receive important clues or useful information from him.

**Whnlyn, Greater Air Elemental Sage:** CR 9; Huge Elemental (Air); HD 21d8+84; hp 178; Init +14; Spd fly 100 ft. (perfect); AC 26 (-2 size, +10 Dex, +8 natural), touch 18, FF 16; BAB +15; Grp +28; Atk slam +23 melee (2d8+5); Full Atk 2 slams +23 melee (2d8+5); Space 10 ft.; Reach 15 ft.; SA Air mastery, whirlwind; SQ Elemental traits, DR 10/-; AL CN; SV Fort +11, Ref +22, Will +10; Str 20, Dex 31, Con 18, Int 14, Wis 12, Cha 11.

**Skills:** Knowledge (arcana) +16, Knowledge (the planes) +18, Listen +16, Spot +16. **Feats:** Alertness, Blind-fight, Combat Reflexes, Flyby Attack, Improved Initiative, Iron Will, Mobility, Power Attack, Spring Attack, Weapon Finesse (slam).



# The Black Orcs Of Noctilius Point

There is a rocky pillar in the Blackwing mountains that extends more than 2,000 feet higher than any surrounding peak. This sheer protrusion of black granite cannot be climbed by normal means. At its top is a half-mile-wide basin utterly devoid of plant life. On this frigid, wind-swept expanse of rock only a single kind of life survives: gigantic dire bats. A colony known as the Noctilius bats (after the name of the pillar) has lived here since time immemorial. With their roosting grounds practically immune from predation, these specially-adapted creatures swoop over the lands below, feeding on livestock and small humanoids at their whim.

Or so the legends say. Unbeknownst to the surface-dwellers, there is far more to Noctilius Point. Eight hundred years ago an orc wizard built a rudimentary flying device and flew himself and several powerful orc accomplices to the top of Noctilius Point. There they slaughtered most of the bats and subdued the rest. After his barbarian allies had trained a cohort of dire bat mounts, the wizard and his allies returned to the surface to fly the rest of their tribe to its new home.

Ever since, the black orcs of Noctilius Point have been a ferocious new faction in the fight for the sky lanes. They long ago abandoned the surface world, leaving its pickings to their bats' natural hunting routines. The orcs now have their sights set on the magical riches of the aerial realms. Over hundreds of years they have bred their dire bats into the largest variety ever seen, and they use these 500-pound Noctilius bats (as they are now called) to raid the sky lanes. Over extended trips they have been known to travel as far as 1,000 miles on a single raiding expedition, bringing along noncombatant trainers and cargo bats to send the riches home while the warriors continue onward.

Over the many years of orc habitation, Noctilius Point has been transformed into anything but a barren wasteland. The orcs have erected a 15-foot-tall stone wall around the entire perimeter to serve as a windbreak. At the center of the plateau is a collection of stone huts and longhouses where the tribe of 250 orcs lives. Surrounding their compound is an endless sea of dire bat habitations.

These gigantic bats roost rightside-up (there are no trees large enough to support their hanging weight) in endless rows of black fur. There are no stables; the barbarian orcs raise their bats as barely-domesticated wild animals, left to tend to themselves when not needed. Thanks to their acute sense of hearing, each individual bat can recognize its rider's particular whistling sound from a great distance, and they wing their way to him when called.

The sky elf navy has known the location of the orcs' home base for some time, but it is too far out of the main trade lanes to mount an effective counterattack. Moreover, Noctilius Point is well defended. It has very little in the way of battlements or siege weapons (none, in fact), but it has one very effective natural defense: more than 500 wild dire bats that naturally roost on the point. Only 100 of the bats are used as orc mounts but the sight of them being attacked would immediately incite the rest. Combatting 500 dire bats at once is a military obstacle that as yet has no easy solution.

The orcs of Noctilius Point call themselves "black orcs." In some ways this appellation is accurate. Over many generations they have adapted to resemble their bat mounts. Their skin is covered with coarse dark fur, obscuring their natural green coloration, and their pig-like snout has become more pronounced and bat-like. Generations of living atop a gigantic mountaintop pillar has robbed them of their light sensitivity, but endless nighttime raids with their bat mounts have led them to retain their darkvision. They tend to be smaller, leaner, and more agile than normal orcs, traits that have helped them in their riding. They receive a +2 bonus to Dexterity and only a +2 bonus to Strength, and no penalty to Charisma. In all other respects they are like normal orcs.

Full statistics for a Noctilius bat and rider can be found on page 103. Black orc raiding parties typically consist of 2-10 Noctilius bats with riders. The riders are usually 6th level barbarians who max out their ranks in Handle Animal and Ride. Lower-level riders are encountered within a day's ride of Noctilius Point but no further; the orc chieftains don't consider them skilled enough to participate in long-distance raids. The tribe can muster up to 100 able-bodied riders, but of them, only 20 are 6th level, and only 40 of the remaining are 3rd level. The rest are 1st-level rangers or barbarians with only basic riding ability.

## Chapter Five

# Denizens of the Sky

## ARACHIAL

The vicious arachial are the primary threat to the sky elves, avians, and other races that inhabit the upper realms of the air. These marauding spider creatures raid settlements and take captives in order to feed off their blood and other life fluids. They spin their captives into cocoons, then slowly consume them, ounce by ounce, over many months or years. During mating season the prey suffer an even more horrific death, since arachial put their egg chambers near the cocooned captives. The young hatch to find the trapped prey waiting for them to eat.

An arachial is a great spider beast with legs that are slightly longer in proportion than those of a giant spider. These allow it to walk higher off the ground. Arachial lack mandibles. Instead they have a wide, toothy mouth. Their front two legs are actually long, black-furred humanoid arms that allow them to wield weapons, forge tools, and work magic. Their hands are round disks set at the end of their arms with eight fingers radiating outward. Elder arachial have short, tough beards that hang from their chins. Males and females are indistinguishable.

See page 24 for arachial racial feats.

### Combat

Arachial rely on ambushes, assassination, and other indirect attacks to destroy their enemies. They use their webbing to construct hiding spots and rely on their ability to scale sheer surfaces to attack from unexpected directions. Arachial love to crawl up the hull of a sky ship, swarming from beneath while a diversionary force approaches the target from above.

**Wall Crawling (Ex):** Arachial have small hooks and suckers on their feet, allowing them to walk across sheer surfaces with ease. Treat an arachial as if it was continually under the effects of a *spider climb* spell. The arachial may climb so long as at least four of his legs are free. A character can pull the spider creature from the wall with a Strength check (DC 20 + 1 per HD of the arachial).

**Webs (Ex):** All arachial can produce light, sticky webbing. Three times per day, an arachial may cast a web at an opponent in order to entangle and trap him. This web attack has a maximum range of 50 feet and a range increment of 10 feet. It is effective against targets the same size or smaller than the arachial. Treat this attack as one made with a net. The web anchors in place, allowing no movement. To escape from an arachial's web, a victim must make an Escape Artist check (DC 20) or break the web with a Strength check (DC 26).

\* **Grapple:** Due to their six legs and stable build, arachial count as one size category larger for purposes of grappling.





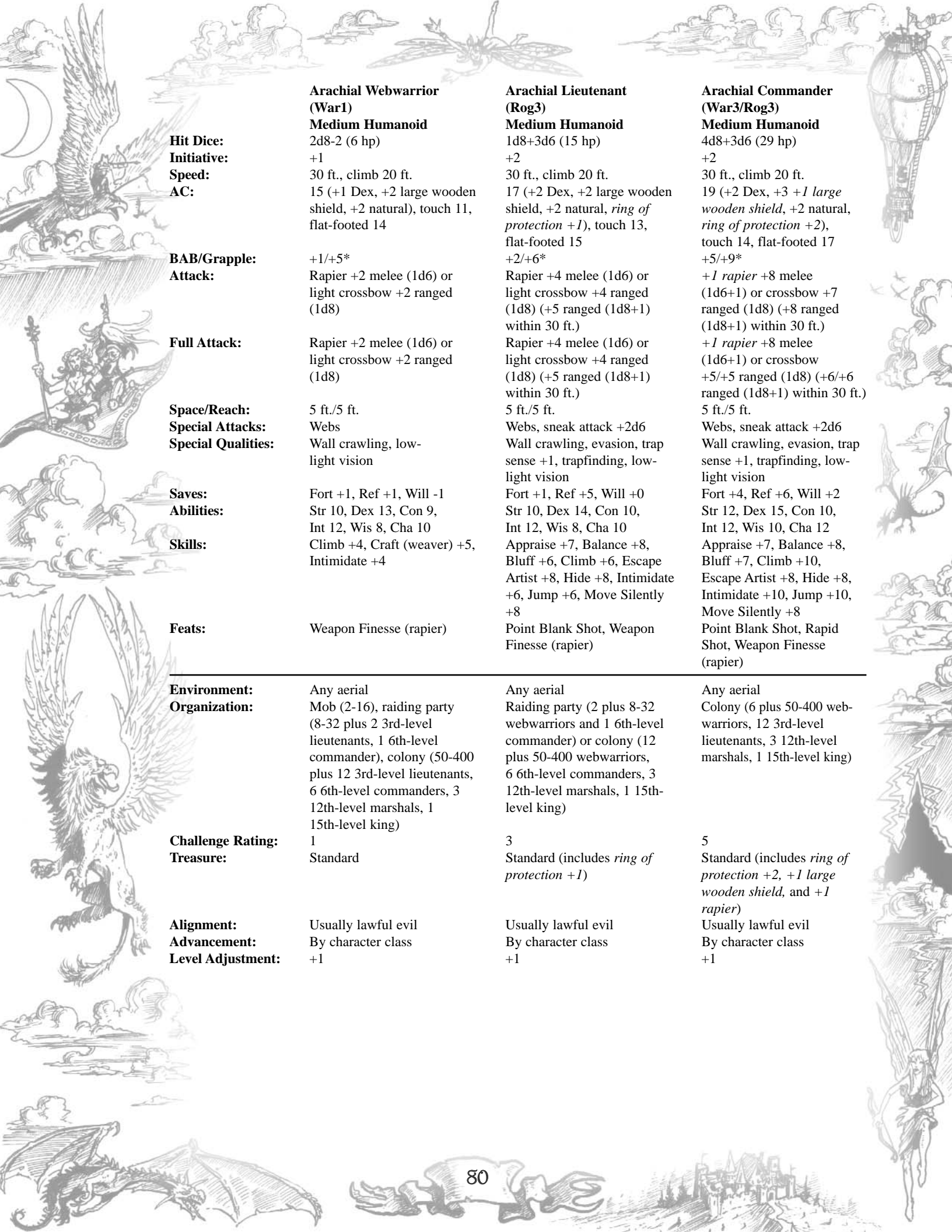

	<b>Arachial Webwarrior</b> (War1) <b>Medium Humanoid</b>	<b>Arachial Lieutenant</b> (Rog3) <b>Medium Humanoid</b>	<b>Arachial Commander</b> (War3/Rog3) <b>Medium Humanoid</b>
<b>Hit Dice:</b>	2d8-2 (6 hp)	1d8+3d6 (15 hp)	4d8+3d6 (29 hp)
<b>Initiative:</b>	+1	+2	+2
<b>Speed:</b>	30 ft., climb 20 ft.	30 ft., climb 20 ft.	30 ft., climb 20 ft.
<b>AC:</b>	15 (+1 Dex, +2 large wooden shield, +2 natural), touch 11, flat-footed 14	17 (+2 Dex, +2 large wooden shield, +2 natural, <i>ring of protection +1</i> ), touch 13, flat-footed 15	19 (+2 Dex, +3 <i>+1 large wooden shield</i> , +2 natural, <i>ring of protection +2</i> ), touch 14, flat-footed 17
<b>BAB/Grapple:</b>	+1/+5*	+2/+6*	+5/+9*
<b>Attack:</b>	Rapier +2 melee (1d6) or light crossbow +2 ranged (1d8)	Rapier +4 melee (1d6) or light crossbow +4 ranged (1d8) (+5 ranged (1d8+1) within 30 ft.)	+1 rapier +8 melee (1d6+1) or crossbow +7 ranged (1d8) (+8 ranged (1d8+1) within 30 ft.)
<b>Full Attack:</b>	Rapier +2 melee (1d6) or light crossbow +2 ranged (1d8)	Rapier +4 melee (1d6) or light crossbow +4 ranged (1d8) (+5 ranged (1d8+1) within 30 ft.)	+1 rapier +8 melee (1d6+1) or crossbow +5/+5 ranged (1d8) (+6/+6 ranged (1d8+1) within 30 ft.)
<b>Space/Reach:</b>	5 ft./5 ft.	5 ft./5 ft.	5 ft./5 ft.
<b>Special Attacks:</b>	Webs	Webs, sneak attack +2d6	Webs, sneak attack +2d6
<b>Special Qualities:</b>	Wall crawling, low-light vision	Wall crawling, evasion, trap sense +1, trapfinding, low-light vision	Wall crawling, evasion, trap sense +1, trapfinding, low-light vision
<b>Saves:</b>	Fort +1, Ref +1, Will -1	Fort +1, Ref +5, Will +0	Fort +4, Ref +6, Will +2
<b>Abilities:</b>	Str 10, Dex 13, Con 9, Int 12, Wis 8, Cha 10	Str 10, Dex 14, Con 10, Int 12, Wis 8, Cha 10	Str 12, Dex 15, Con 10, Int 12, Wis 10, Cha 12
<b>Skills:</b>	Climb +4, Craft (weaver) +5, Intimidate +4	Appraise +7, Balance +8, Bluff +6, Climb +6, Escape Artist +8, Hide +8, Intimidate +6, Jump +6, Move Silently +8	Appraise +7, Balance +8, Bluff +7, Climb +10, Escape Artist +8, Hide +8, Intimidate +10, Jump +10, Move Silently +8
<b>Feats:</b>	Weapon Finesse (rapier)	Point Blank Shot, Weapon Finesse (rapier)	Point Blank Shot, Rapid Shot, Weapon Finesse (rapier)
<b>Environment:</b>	Any aerial	Any aerial	Any aerial
<b>Organization:</b>	Mob (2-16), raiding party (8-32 plus 2 3rd-level lieutenants, 1 6th-level commander), colony (50-400 plus 12 3rd-level lieutenants, 6 6th-level commanders, 3 12th-level marshals, 1 15th-level king)	Raiding party (2 plus 8-32 webwarriors and 1 6th-level commander) or colony (12 plus 50-400 webwarriors, 6 6th-level commanders, 3 12th-level marshals, 1 15th-level king)	Colony (6 plus 50-400 webwarriors, 12 3rd-level lieutenants, 3 12th-level marshals, 1 15th-level king)
<b>Challenge Rating:</b>	1	3	5
<b>Treasure:</b>	Standard	Standard (includes <i>ring of protection +1</i> )	Standard (includes <i>ring of protection +2</i> , <i>+1 large wooden shield</i> , and <i>+1 rapier</i> )
<b>Alignment:</b>	Usually lawful evil	Usually lawful evil	Usually lawful evil
<b>Advancement:</b>	By character class	By character class	By character class
<b>Level Adjustment:</b>	+1	+1	+1

## AVIAN

	<b>Avian Commoner (War1)</b> <b>Medium Humanoid</b>	<b>Avian Champion (Bbn4)</b> <b>Medium Humanoid</b>	<b>Avian Warleader (Bbn8)</b> <b>Medium Humanoid</b>
<b>Hit Dice:</b>	1d8 (4 hp)	4d12+4 (30 hp)	8d12+16 (68 hp)
<b>Initiative:</b>	+0	+0	+1
<b>Speed:</b>	30 ft., fly 80 ft. (average)	40 ft., fly 90 ft. (good)	40 ft., fly 90 ft. (good)
<b>AC:</b>	13 (+3 studded leather), touch 10, flat-footed 13	14 (+4 +1 studded leather), touch 10, flat-footed 14	16 (+1 Dex, +5 +2 studded leather), touch 11, flat-footed 15
<b>BAB/Grapple:</b>	+1/+2	+4/+6	+8/+11
<b>Attack:</b>	Greatsword +3 melee (1d12+1) or javelin +1 ranged (1d6+1)	+1 greatsword +8 melee (1d12+4) or javelin +4 ranged (1d6+2)	+2 greatsword +14 melee (1d12+8) or javelin +9 ranged (1d6+3)
<b>Full Attack:</b>	Greatsword +3 melee (1d12+1) or javelin +1 ranged (1d6+1)	+1 greatsword +8 melee (1d12+4) or javelin +4 ranged (1d6+2)	+2 greatsword +14/+9 melee (1d12+8) or javelin +9/+4 ranged (1d6+3)
<b>Space/Reach:</b>	5 ft./5 ft.	5 ft./5 ft.	5 ft./5 ft.
<b>Special Attacks:</b>	Grasping attack	Grasping attack	Grasping attack
<b>Special Qualities:</b>		Fast movement, illiteracy, rage 2/day, uncanny dodge, trap sense +1	Fast movement, illiteracy, rage 3/day, improved uncanny dodge, trap sense +2, DR 1/-
<b>Saves:</b>	Fort +2, Ref +0, Will +0	Fort +5, Ref +1, Will +1	Fort +8, Ref +3, Will +3
<b>Abilities:</b>	Str 13, Dex 10, Con 11, Int 9, Wis 11, Cha 8	Str 14, Dex 10, Con 12, Int 10, Wis 11, Cha 10	Str 16, Dex 12, Con 14, Int 11, Wis 12, Cha 11
<b>Skills:</b>	Handle Animal +4, Intimidate +3	Handle Animal +7, Intimidate +7, Listen +7, Survival +7	Handle Animal +12, Intimidate +11, Listen +11, Survival +9
<b>Feats:</b>	Weapon Focus (greatsword)	Agile Flier, Weapon Focus (greatsword)	Agile Flier, Power Attack, Weapon Focus (greatsword)
<b>Environment:</b>	Mountain peaks, any aerial	Mountain peaks, any aerial	Mountain peaks, any aerial
<b>Organization:</b>	Solitary, flock (6-24 plus 2 4th-level champions and 1 8th-level warleader), clan (18-124 plus 4 4th-level champions, 2 8th-level warleaders, and 1 12th-level headman)	Flock (2 plus 6-24 avian commoners and 1 8th-level warleader) or clan (4 plus 18-124 avian commoners, 2 8th-level warleaders, and 1 12th-level headman)	Clan (2 plus 18-124 avian commoners, 4 4th-level champions, and 1 12th-level headman)
<b>Challenge Rating:</b>	1/2	4	8
<b>Treasure:</b>	Standard	Standard (includes +1 studded leather armor and +1 greatsword)	Standard (includes +2 studded leather armor and +2 greatsword)
<b>Alignment:</b>	Usually chaotic neutral	Usually chaotic neutral	Usually chaotic neutral
<b>Advancement:</b>	By character class	By character class	By character class
<b>Level Adjustment:</b>	+0	+0	+0

Avians are wild, impulsive barbarians of the sky. They fly in great flocks organized into clans, each of which follows a pattern of migration that may take them several years to complete. Other avian clans establish permanent settlements at the uppermost reaches of mountain peaks, building permanent nests from which they conduct trade with dwarves and other races and launch raids on their hated enemies the arachials.

Avians look like a cross between a human, orc, and bird. They have flat, elongated noses similar to an orcs but their hairless bodies resemble a human's. Colorfully feathered wings sprout from their backs and extend several feet above their heads. Rather than feet, avians have powerfully built, wickedly sharp talons.

See page 24 for avian racial feats.

### Combat

In battle, avians charge headlong into the fray. They love to gain altitude above their enemies then swoop down to attack. Avians rarely stop to consider tactics or battle plans, relying on a powerful charge to break their enemies and scatter them to the winds. When attacking targets on the ground, they love to pluck their enemies from the earth, carry them into the air, then drop them to their deaths.

**Grasping Attack (Ex):** On a successful grapple check, an avian may grab and carry aloft an unwilling target. The avian may drop his victim as a move action. While being carried, the avian's victim suffers a -4 penalty to his Dexterity. If he attacks the avian carrying him, the avian counts as having lost his Dexterity bonus to AC even if a class ability or magic item makes this impossible.

# CLOUD COLONY

<b>Hit Dice:</b>	<b>Gargantuan Plant</b>
<b>Initiative:</b>	24d8+192 (300 hp)
<b>Speed:</b>	-3
<b>AC:</b>	10 ft., fly 20 ft. (clumsy)
	9 (-4 size, +6 natural, -3 Dex), touch 3, flat-footed 9
<b>BAB/Grapple:</b>	+5*/+16
<b>Attack:</b>	Tendrils +16 melee (1d8+11)
<b>Full Attack:</b>	8 tendrils +16 melee (1d8+11)
<b>Space/Reach:</b>	30 ft./15 ft.
<b>Special Qualities:</b>	Plant, blindsight, camouflage, entrapment
<b>Saves:</b>	Fort +14, Ref +8, Will +8
<b>Abilities:</b>	Str 32, Dex 4, Con 26, Int 6, Wis 12, Cha 10
<hr/>	
<b>Environment:</b>	Any temperate or aerial
<b>Organization:</b>	Solitary
<b>Challenge Rating:</b>	12
<b>Treasure:</b>	Standard
<b>Alignment:</b>	Always neutral
<b>Advancement:</b>	25-32 HD (Gargantuan)



A cloud colony is a large mass of pulpy vegetable matter that lies in wait for creatures that fly near or tread upon it. From a distance, the colony looks like a small, floating cloud realm choked with plants or, if the colony has landed somewhere, an overly thick patch of long, dense grass. When the cloud colony senses prey drawing close, it extends its long tendrils to grasp its victim and drain blood from him. These carnivorous plants require blood to sustain themselves and often take root near pathways, trade routes, or on cloud realms that teem with life. Once the cloud colony has decimated life in a region, it uproots itself and floats to a new location. Some of these monstrosities pose as independent, floating realms of vegetable matter. Curious travelers or birds looking for a place to roost land upon the colony and serve as its next meal.

Cloud colonies are deceptively intelligent. While they lack the cunning or planning equal to a human, they are smart enough to seek out well-traveled areas and move on after a month or so in a location. The colony is careful to never draw too much attention to itself, as it lacks the capabilities to deal with ranged weapons or powerful spells.

Sometimes, a cloud colony may go long enough without food that the thing is gripped with a deep, maddening hunger. In this state, a cloud colony may attempt to land atop a village or otherwise directly attack travelers and other potential meals.

## Combat

The cloud colony relies on its innocent appearance to draw prey near. Normally, it lies dormant in a spot where it expects creatures to travel or land. Once prey comes into contact with its surface, the creature unleashes its tendrils to grab its prey and drain their life from them. In addition, it shapes its body to create steep, slippery slopes that trap its prey and leave them at its mercy.

Once the colony's victim is dead, the plant monster opens a shallow enclosure within its body where it drags the corpse and begins to slowly digest it and drain it of blood. Most of a colony's treasure can be found tucked within these hollows in its body along with the skeletal remains of its previous victims.

\* **BAB:** The cloud colony's base attack bonus is based on the attack power of its individual tendrils, which are treated as 7 HD creatures for purpose of attack calculations.

**Plant:** Immune to poison, sleep effects, paralysis, stunning, polymorphing, critical hits, and mind-influencing effects.

**Camouflage (Ex):** To the casual observer, the cloud colony appears to be nothing more than a simple lump of plant life or a thick stretch of grass. Any creature or character approaching a cloud colony must make a Spot check (DC 20) to notice anything is amiss. Note that this check is voluntary. Only characters who have a reason to suspect the colony's presence may make this check. Characters that have previously dealt with these creatures gain a +5 competence bonus to their check.

**Entrapment (Ex):** The colony can control the shape and disposition of its body mass. When prey walks upon it and the colony prepares to strike, it can form tall, steep barriers by surging its mass upward. As a move-equivalent action, the colony can form a barrier 10 feet high anywhere along its body. The creature normally does this to create a ring that traps its prey. At any one time, the colony may only form one wall in this manner. Trapped creatures may climb over this barrier, but the colony shakes and shudders as its prey does so, making the Climb skill check rather difficult (DC 20).



# CLOUD LURKER

## Cloud Lurker Large Aberration

**Hit Dice:** 4d8+12 (30 hp)  
**Initiative:** +5  
**Speed:** 10 ft., fly 60 ft. (average)  
**AC:** 16 (+1 Dex, +6 natural, -1 size), touch 10, flat-footed 15  
**BAB/Grapple:** +3/+11  
**Attacks:** Tentacle slap +7 melee (1d8+4)  
**Full Attack:** 2 tentacle slaps +7 melee (1d8+4) and bite +2 melee (1d6+4)  
**Space/Reach:** 5 ft./15 ft.  
**Special Attacks:** Improved grab, squeeze  
**Special Qualities:** *Obscuring mist* 3/day  
**Saves:** Fort +4, Ref +2, Will +5  
**Abilities:** Str 18, Dex 12, Con 17, Int 12, Wis 13, Cha 10  
**Skills:** Hide +7, Listen +5, Spot +8, Survival +4  
**Feats:** Blind-Fight, Improved Initiative

## Cloud Devourer Gargantuan Aberration

**Hit Dice:** 20d8+140 (230 hp)  
**Initiative:** +4  
**Speed:** 10 ft., fly 60 ft. (average)  
**AC:** 19 (+13 natural, -4 size), touch 6, flat-footed 19  
**BAB/Grapple:** +15/+43  
**Attacks:** Tentacle slap +19 melee (4d6+12)  
**Full Attack:** 2 tentacle slaps +19 melee (4d6+12) and bite +17 melee (2d6+12)  
**Space/Reach:** 25 ft./15 ft.  
**Special Attacks:** Improved grab, squeeze  
**Special Qualities:** *Obscuring mist* 9/day  
**Saves:** Fort +13, Ref +8, Will +13  
**Abilities:** Str 34, Dex 10, Con 25, Int 14, Wis 15, Cha 10  
**Skills:** Hide +11, Listen +25, Move Silently +4, Spot +25, Survival +25  
**Feats:** Blind-Fight, Combat Reflexes, Hover, Improved Initiative, Improved Natural Attack (tentacle slap), Lightning Reflexes, Skill Focus (Hide), Stealthy

**Environment:** Any aerial  
**Organization:** Solitary, pod (2-7)  
**Challenge Rating:** 4  
**Treasure:** Standard  
**Alignment:** Usually neutral evil  
**Advancement:** 5-16 HD (Huge), 17-32 HD (Gargantuan)

**Environment:** Any aerial  
**Organization:** Solitary  
**Challenge Rating:** 9  
**Treasure:** Standard  
**Alignment:** Usually neutral evil  
**Advancement:** —

The cloud lurker is an intelligent, vicious predator that hides within natural clouds and uses its long, scaled tentacles to grab passing creatures and drag them to its fanged maw.

The cloud lurker is a scaly, lizard-like creature. Its spherical body is covered with mottled blue and white scales. Two long, winding tentacles extend from its sides, both of which have the same coloration as the main body. Its circular, yellow eyes peer over a fanged maw positioned vertically between its eyes.

## Combat

Cloud lurkers are common predators in the upper atmosphere. They hide within the outer edges of clouds, keeping a keen eye out for approaching sky ships, birds, or other potential prey. When a creature draws near the lurker lashes out with its tentacles, hoping to snare and devour prey before it can offer much resistance. Cloud lurkers are notoriously greedy and have been known to congregate in pods in order to attack merchant ships. They maintain lairs in caves and air pockets within cloud islands. There, they pile coins, items, and other trinkets from their victims. These creatures' vanity drives them to wear whatever rings, jewelry, or other items they find suitable to their strange forms.

**Improve Grab (Ex):** To use this ability, the cloud lurker must hit with one of its tentacle attacks against a creature of Medium size or smaller. If it gets a hold, it squeezes.

**Squeeze (Ex):** A cloud lurker that gets a hold on a creature one or more sizes smaller automatically deals damage from one of its tentacles and uses its bite with a +5 circumstance bonus to its attack roll. A cloud lurker can use this ability on creatures of size Medium or smaller; a cloud devourer uses it on creatures of size Huge or smaller.

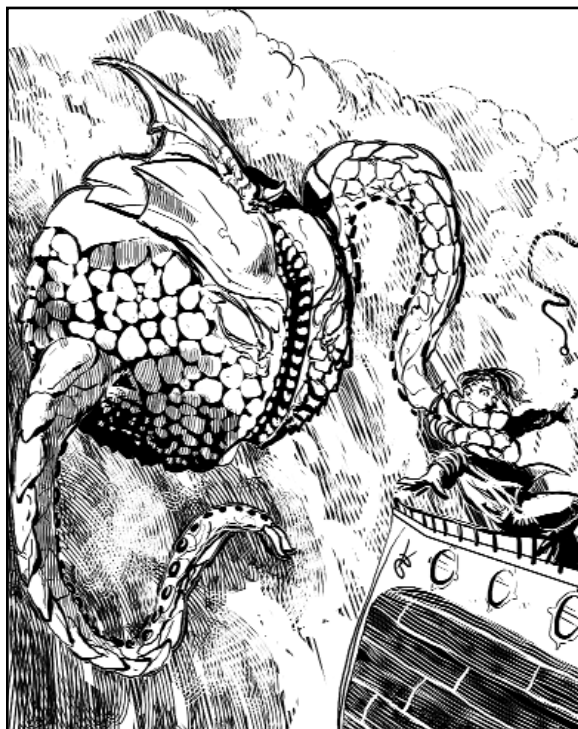

**Obscuring Mist (Su):** Three times per day, the cloud lurker may use *obscuring mist* as a free action. Treat this as the spell cast by a sorcerer whose caster level equals the lurker's hit dice. A cloud devourer may use this ability nine times per day.

## Cloud Devourer

A select few cloud lurkers grow to enormous sizes. These so-called cloud devourers are absolutely massive. They threaten not just sky sailors but the very ships they sail on. Even dragons avoid them. When a cloud devourer is sighted, the sky elf navy immediately sends out a warfleet to destroy it. But the creatures are stealthy by their very nature, and more than one has preyed on the sky lanes for many months before being found.

## DEVIL, SKY FIEND

<b>Hit Dice:</b>	5d8+5 (27 hp)
<b>Initiative:</b>	+3
<b>Speed:</b>	30 ft., fly 60 ft. (good)
<b>AC:</b>	19 (+3 Dex, +6 natural), touch 13, flat-footed 16
<b>Attack:</b>	Bite +8 melee (2d6+3)
<b>Full Attack:</b>	Bite +8 melee (2d6+3) and 2 claws +6 (1d8+1)
<b>Space/Reach:</b>	5 ft./5 ft.
<b>Special Attacks:</b>	Battle fury, hell wind, thunder shriek
<b>Special Qualities:</b>	Damage reduction 10/silver or good, SR 15, cold immunity
<b>Saves:</b>	Fort +5, Ref +7, Will +4
<b>Abilities:</b>	Str 16, Dex 17, Con 13, Int 14, Wis 10, Cha 12
<b>Skills:</b>	Balance +11, Concentration +9, Knowledge (the planes) +10, Sense Motive +6, Spot +10, Tumble +13
<b>Feats:</b>	Dodge, Multiattack
<b>Environment:</b>	Any land, underground, or aerial
<b>Organization:</b>	Solitary or flock (2-12)
<b>Challenge Rating:</b>	4
<b>Treasure:</b>	Standard
<b>Alignment:</b>	Always lawful evil (see below)
<b>Advancement:</b>	6-8 HD (Medium), 9-16 HD (Large)



The sky fiend is a horrendous cross between humanoid, bird, and devil that lives on many of Hell's layers. Normally employed as scouts and skirmishers by the dukes of Hell, these beasts sometimes come to the prime plane under the compulsion of a powerful summoner or at the direction of their commander in Hell's hierarchy. Often, these creatures scout out the prime plane in order to uncover promising targets for diabolic strikes or to aid a cabal of devil worshippers. In their natural habitat, sky fiends are carrion eaters who flock upon the fields of the dead from Hell's unceasing wars. The dukes of Hell, always eager to make use of any resource available, capture these beasts, strip them of their wings, rebuild them with items from their workshops, and bind them to their service.

A sky fiend naturally appears as a bird-winged humanoid with light blue skin, coal black eyes, and a short, stubby beak. In place of feet they have small talons they use to carry items. Once the dukes of Hell have outfitted them, though, they bear little resemblance to their natural form. Their wings are cut from their backs and their beaks are torn from their faces. In their place are a pair of steel wing frames covered with metallic feathers forged in Hell's workshops and a vicious steel-bladed snout. Tubes set into their bodies contain a powerful sedative that continually keeps the sky fiend obedient to its master. When the sedatives are close to running out, the fiend is ordered to return to Hell's workshops for a refill. Occasionally, a sky fiend breaks free of this control. A small cabal of these creatures lurks at the edge of Hell's domain, picking off devils that fall into their clutches and plotting endlessly to destroy their oppressors. Another group of sky fiends maintains outposts on the prime plane. These creatures seek to uncover weapons, magic, and artifacts that can help them in their war with Hell's rulers.

## Combat

In battle, the sky fiend relies on its flying ability to close with its foes and pounce upon them before they have a chance to ready a defense. Under the compulsion of their overlords, once they engage in battle they attack recklessly, usually fight-

ing to the death. When fighting in the air, hell fiends lurk behind clouds before attacking. As they lack long range attacks and weapons, they prefer to close the distance to their foes as quickly as possible.

**Battle Fury (Ex):** The control exerted over a sky fiend causes a constant internal struggle within its mind. The pressure to obey and the drive to rebel builds up within a sky fiend and explodes into a tremendous fury in battle. Once per day, the sky fiend may rage as per the barbarian class ability.

**Hell Wind (Su):** Three times per day as a standard action, the sky fiend may flap its wings at an incredibly rapid rate. This action produces a searing hot wind that cleaves through the sky fiend's enemies. This ability creates a 40 foot cone of superheated air that deals 4d6 damage. A Reflex save (DC 15) allows a creature to take half damage.

**Thunder Shriek (Su):** Once per day, the sky fiend may emit a piercing shriek that can shatter glass and deafen its victims. When the sky fiend uses this ability, all non-sky fiends within 20 feet of it suffer 3d8 damage and are struck deaf for 4d6 hours. A Fortitude save (DC 20) halves the damage and nullifies the deafness caused by this ability.

## DIRE HAWK

	<b>Large Animal</b>
<b>Hit Dice:</b>	4d8+8 (22 hp)
<b>Initiative:</b>	+5
<b>Speed:</b>	10 ft., fly 60 ft. (average)
<b>AC:</b>	16 (-1 size, +5 Dex, +2 natural), touch 14, flat-footed 11
<b>BAB/Grapple:</b>	+3/+10
<b>Attack:</b>	Claw +5 melee (1d6+3)
<b>Full Attack:</b>	2 claws +5 melee (1d6+3) and bite +0 melee (1d8+2)
<b>Space/Reach:</b>	10 ft./5 ft.
<b>Special Qualities:</b>	Low-light vision
<b>Saves:</b>	Fort +5, Ref +9, Will +1
<b>Abilities:</b>	Str 16, Dex 20, Con 12, Int 2, Wis 14, Cha 10
<b>Skills:</b>	Listen +4, Spot +15
<b>Feats:</b>	Alertness, Flyby Attack

---

<b>Environment:</b>	Temperate forests or aerial
<b>Organization:</b>	Solitary or pair
<b>Challenge Rating:</b>	3
<b>Treasure:</b>	None
<b>Alignment:</b>	Always neutral
<b>Advancement:</b>	5-12 HD (Large)

Dire hawks are enormous birds of prey with a vicious glint in their eyes. They prowl the skies looking for weaker prey, which they snatch off the ground before it has time to react. Dire hawks soaring at high altitudes are a threat to sky ships, which have been known to lose sailors on deck to the fly-by attacks of these predators.

A dire hawk has a wingspan of up to 20 feet and weighs 500 pounds.

### Combat

Dire hawks attack with their vicious talons. If they are ever forced to fight on the ground, they also use their bite.

**Skills:** Dire hawks receive a +4 racial bonus to Spot checks.

### Training a Dire Hawk

A dire hawk can be trained as a mount. It requires six weeks of work and a successful Handle Animal check (DC 15 for regular riding, DC 20 for combat riding). Riding a dire hawk requires an exotic saddle. A dire hawk can fight while carrying a rider, but the rider cannot also attack unless he succeeds in a Ride check (DC 10).

A young dire hawk costs 2,500 gp, while a dire hawk egg sells for 1,500 gp.

**Carrying Capacity:** A light load for a dire hawk is up to 300 lbs.; a medium load, 301-600 lbs.; a heavy load, 601-900 lbs.





# DRAGONS

Unless otherwise noted, the following two new types of dragons use all the standard d20 rules for dragonkind. Refer to the standard d20 rules for information on dragon physical attacks, special abilities, feats, skills, and other information that applies to all dragons. Only the statistics unique to star and wind dragons are presented here.

## DRAGON, STAR

**Environment:****Dragon (Fire)**

Any aerial

**Organization:**

Wyrmling, very young, young, juvenile, and young adult: solitary, clutch (2-5), or flight (6-12); adult, mature adult, old, very old, ancient wyrm, or great wyrm: solitary or mated pair (2 and 2-5 offspring)

**Challenge Ratings:**

Wyrmling 2; very young 3; young 4; juvenile 7; young adult 10; adult 12; mature adult 15; old 17; ancient 20; wyrm 21; great wyrm 23

**Treasure:**

Double standard

**Alignment:**

Always chaotic evil

**Advancement:**

Wyrmling 7-8 HD (Small); very young 9-11 HD (Medium-size); young 13-17 HD (Medium-size); juvenile or young adult 20-22 HD (Large); adult 22-24 HD (Huge); mature adult 24-26 HD (Huge); old 26-28 HD (Huge); very old 28-30 HD (Huge); ancient 31-32 HD (Gargantuan); wyrm 34-35 HD (Gargantuan); great wyrm 37-40 HD (Gargantuan)



Soaring high above the upper atmosphere, star dragons are a rare breed of wyrm that exists in extremely small numbers. Evil and predatory to the core, these beasts occasionally swoop down from their stratospheric realms to smash sky ships, devour their crews, and carry off their cargoes. Star dragons have deep blue hides dotted with sparkling, gem-like studs. These studs twinkle in the night sky, giving these dragons their name and helping them approach their prey unnoticed at night.

A star dragon's face rarely betrays any emotion. While these creatures exult in death and destruction, they maintain a stony, distant visage. Their eyes are dull, gray orbs while their jaws are covered in a tough, spiny outer shell that masks most expressions they can muster. A spiny frill extends down their backs, while their great wings are as black as night when they fully extend them.

These dragons are surprisingly agile flyers. Unlike most dragons, their ability to fly improves with age. Younger star dragons learn to maneuver through the air with practiced ease, while older ones learn to compensate for their unwieldy bulk with experience, cunning, and tactics.

Star dragons live in great cloud realms that drift high in the sky. These realms are riddled with interconnected caves, some of which lead to a large, central vault where the star dragon lairs and keeps its treasure. The cruelest of these beasts enjoy carrying victims to their homes and letting them

loose in their labyrinthine passages, spending days or even weeks stalking their helpless prey before killing them. Star dragons are exceptionally cruel and enjoy not only the thrill of destroying an enemy but stretching the pain and agony they inflict over as long a duration as possible. Deeply territorial, star dragons jealously guard the regions of sky they claim as their own. Aside from the brief period of their life when they mate, star dragons barely tolerate each other's presence and almost always duel to the death when they cross paths.

Star dragons are capable of eating almost anything, from plants (including trees) to the flesh of almost any creature that breathes. They prefer elves to other meals, and sometimes embark on great hunts to stalk and kill elf sky ships, caravans, or trading parties. Star dragons also have a taste for the flesh of other dragons. When a dragon of any color, be it good or evil, enters a star dragon's territory, the star dragon eventually attacks the beast and fights to the death.

Star dragons consider themselves the greatest of dragonkind. Their theology and myth cycles teach that the greatest dragons were given the highest reaches of the sky. Dragons that deign to lurk in dirt and rock burrows are mere peons not fit to compete with a star dragon for space or prey.

While star dragons prefer to remain in the upper clouds, they sometimes fly down to the surface world for a night of food and amusement. Star dragons scoff at the cities and villages built by man and use their breath weapon and special attacks to start tremendous fires. While the flames grow, they glide above the city and leisurely pick off those who run from the fire. In the confusion, the star dragon can go unnoticed as it blends in with the night sky. Some towns have been repeatedly attacked by a star dragon yet never realized the true source of their torment. While the town guard seeks out an arsonist or rogue invoker, the dragon continues to launch its raids with impunity.

### Combat

Star dragons fight on the wing. They only take to the ground if forced to by spells or injury. They swoop to attack their foes, using their shooting star and cloak of fear and flame abilities to smash through opponents and scatter them to the winds. Ancient star dragons literally fly through sky ships to destroy them, then swoop down to pick off sailors and cargo as they tumble earthward. Star dragons are sometimes drawn to attack ground settlements and travelers, especially if they clear out the prey and other resources in the aerial realms near their lairs.

**Breath Weapon (Su):** A star dragon's breath weapon is a flaming, miniature comet that slams into its target and explodes in a burst of flames. The dragon must make a



### Star Dragons by Age

Age	Size	Hit Dice (hp)	Str	Dex	Con	Int	Wis	Cha	BAB/Grpl	Atk	Fort Save	Ref Save	Will Save	Breath Wpn. (DC)	Fright DC
Wyrmling	S	6d12 (39)	13	12	10	6	8	10	+6/+3	+8	+5	+6	+4	2d8 (12)	-
Very young	M	8d12+8 (60)	15	10	12	8	10	10	+8/+10	+10	+7	+6	+6	4d8 (14)	-
Young	M	12d12+12 (90)	17	10	12	8	10	10	+12/+15	+15	+9	+8	+8	6d8 (16)	-
Juvenile	L	18d12+36 (153)	19	10	14	10	12	12	+18/+26	+21	+13	+11	+12	8d8 (18)	-
Young adult	L	19d12+38 (161)	21	10	14	10	12	12	+19/+28	+23	+14	+12	+13	10d8 (20)	11
Adult	H	21d12+63 (199)	27	10	16	12	14	14	+21/+37	+27	+16	+13	+15	12d8 (22)	12
Mature adult	H	23d12+69 (218)	31	10	16	12	14	14	+23/+51	+31	+17	+14	+16	14d8 (24)	13
Old	H	25d12+100 (262)	35	10	18	14	16	14	+25/+55	+35	+19	+15	+18	16d8 (26)	14
Very old	H	27d12 +135 (310)	37	10	20	14	16	16	+27/+56	+38	+21	+16	+19	18d8 (28)	16
Ancient	G	30d12+180 (375)	41	10	22	16	18	18	+30/+57	+41	+24	+18	+22	20d8 (30)	19
Wyrmling	G	33d12+231 (445)	43	10	24	16	20	20	+33/+61	+45	+26	+19	+24	22d8 (32)	21
Great wyrmling	G	36d12+288 (522)	45	10	26	18	22	22	+36/+65	+49	+29	+21	+27	24d8 (34)	24

### Star Dragon Abilities by Age

Age	Speed	Initiative	AC	Special Abilities	CL	SR
Wyrmling	30 ft., fly 200 ft. (poor)	+1	14 (+1 size, +1 Dex, +2 natural), touch 12, FF 13	Fire subtype, night camouflage	-	-
Very young	30 ft., fly 210 ft. (average)	+0	13 (+3 natural), touch 10, FF 13		-	-
Young	30 ft., fly 220 ft. (average)	+0	16 (+6 natural), touch 10, FF 16	Shooting star	-	-
Juvenile	30 ft., fly 230 ft. (good)	+0	18 (-1 size, +9 natural), touch 9, FF 18		-	-
Young adult	30 ft., fly 240 ft. (good)	+0	21 (-1 size, +12 natural), touch 9, FF 21	DR 5/magic	1st	18
Adult	30 ft., fly 250 ft. (good)	+0	23 (-2 size, +15 natural), touch 8, FF 23	Cloak of fear and flame	3rd	20
Mature adult	30 ft., fly 260 ft. (good)	+0	26 (-2 size, +18 natural), touch 8, FF 26	DR 10/magic	5th	21
Old	30 ft., fly 270 ft. (good)	+0	29 (-2 size, +21 natural), touch 8, FF 29	Wall of fire	7th	22
Very old	30 ft., fly 280 ft. (perfect)	+0	32 (-2 size, +24 natural), touch 8, FF 32	DR 15/magic	9th	24
Ancient	30 ft., fly 290 ft. (perfect)	+0	33 (-4 size, +27 natural), touch 6, FF 33		11th	26
Wyrmling	30 ft., fly 300 ft. (perfect)	+0	36 (-4 size, +30 natural), touch 6, FF 36	DR 20/magic	13th	28
Great wyrmling	30 ft., fly 320 ft. (perfect)	+0	39 (-4 size, +33 natural), touch 6, FF 39	Striking star	15th	30



ranged touch attack to hit a target. The comet detonates in a 20 ft. spread, dealing the listed breath weapon damage. Creatures that make the listed Reflex save DC take half damage. The initial target of the comet takes an additional 3d6 damage from the rock's impact. If the star dragon misses with its ranged touch attack, treat the comet as a grenadelike weapon that detonates at whatever point it strikes.

**Fire Subtype (Ex):** Fire immunity, double damage from cold except on a successful save.

**Night Camouflage (Ex):** The star dragon's unique hide allows it to blend in with the night sky. When flying at night, the star dragon gains a +8 racial bonus to all Hide checks.

**Shooting Star (Su):** Three times per day, the star dragon may wreath itself in a fiery aura when making a charge attack or while using the Flyby Attack feat. When attacking in this manner, the star dragon deals double damage. In addition, all damage it deals counts as fire damage.

**Cloak of Fear and Flame (Su):** Once per day, the star dragon may call upon a massive eruption of fire that cloaks



it in flame and batters its enemies with magical energy. All creatures in a 60-foot radius around the dragon are caught in a firestorm that deals damage equal to its breath weapon. A successful Reflex save (DC equal to the dragon's breath weapon DC) allows a character to take half damage. In addition, after using this ability the star dragon forces all creatures within range of its frightful presence ability to make a second save against that effect at a -2 penalty.

**Wall of Fire (Su):** As a spell-like ability, the star dragon may cast *wall of fire* as a sorcerer whose level equals its hit dice. Unlike the standard spell, this wall does not need an anchor point on which to rest. The dragon may suspend it in mid-air.

**Striking Star (Su):** Once per day, the star dragon may transform itself into a gigantic, flaming sphere of energy. The dragon uses a charge action to activate this ability. When it makes its charge, the dragon makes a touch attack against its target. On a successful hit, the dragon's opponent takes 36d8 points of fire damage with no save allowed.

## DRAGON, WIND



**Environment:**  
**Organization:**

### Dragon (Air)

Any aerial  
Wyrmling, very young, young, juvenile, and young adult: solitary or clutch (1-4); adult, mature adult, old, very old, ancient, wyrm, or great wyrm: solitary or mated pair (2 plus 1-4 young)

**Challenge Ratings:** Wyrmling 3; very young 4; young 6; juvenile 9; young adult 12; adult 14; mature adult 17; old 19; very old 20; ancient 22; wyrm 23; great wyrm 25



**Treasure:** Double standard  
**Alignment:** Always chaotic neutral  
**Advancement:** Wyrmling 5-6 HD (Small); very young 7-9 HD (Medium); young 10-12 HD (Medium); juvenile 13-15 HD (Large); young adult 16-18 HD (Large); adult 19-21 HD (Huge); mature adult 22-24 HD (Huge); old 25-27 HD (Huge); very old 28-30 HD (Huge); ancient 31-33 HD (Gargantuan); wyrm 34-36 HD (Gargantuan); great wyrm 37+ HD (Gargantuan)



Wind dragons are serpentine, winged wyrms that dwell amongst the stratospheric winds that blow high in the upper atmosphere. Capricious, jovial, and wild, the only thing predictable about these creatures is their utterly unpredictable moods and personalities. Wind dragons live for the moment. They may stop a sky ship to talk to its captain about the construction of his vessel one week and then carelessly topple a ship the next just to watch the crew and cargo tumble through the air. In many ways, wind dragons are like energetic children given the power to fill their every whim at a moment's notice.



From a distance, a wind dragon appears quite like a winged serpent. Their long, sinuous bodies coil and slide through the air, while their slender, long limbs are easily overlooked until they draw near. A wind dragon's scales are a light, sky blue, while their underbodies are a bright, clean white. Their faces are plain, looking more like a serpent's than a dragon's. They lack the frills, horns, or whiskers commonly found on other draconic species. Their wings are feathered, with striking patterns of bright red, blue, and green. Each wind dragon has a unique pattern of colors on its wings and they take great pride in preening and maintaining them.



Wind dragons lair amongst the clouds or in high mountain peaks. Unlike other dragons, they tend to spend little time in their lairs, preferring to keep them more as treasure vaults. A wind dragon's lair is invariably stocked with dozens of traps to kill or capture intruders, as these creatures share the typical draconic lust for gold, gems, and other valuables. When a wind dragon is in its lair, it rolls in its treasure and plays with its riches until it grows bored and decides to seek out excitement elsewhere.



Wind dragons are highly magical, nimble creatures. While they lack the strength and fortitude of other dragons, they compensate with their phenomenal quickness and magical skills. Like serpents, wind dragons are swift and nimble. As they grow older, their reflexes and speed increase along with their bulk, largely due to their magical nature.



Wind dragons eat a wide range of foods. They can subsist off vegetation, but prefer fresh meat. Owing to their magical natures, they can consume the life force of air elementals and often hunt such creatures. Some wind dragons prefer to eat as wide a range of foods as possible, driving them to seek out new prey or devour strange creatures at every chance they get.



Owing to their capricious natures, wind dragons rarely carve out a territory of their own. However, they still viciously guard the area immediately around their treasure vaults and eagerly destroy those who may know of their



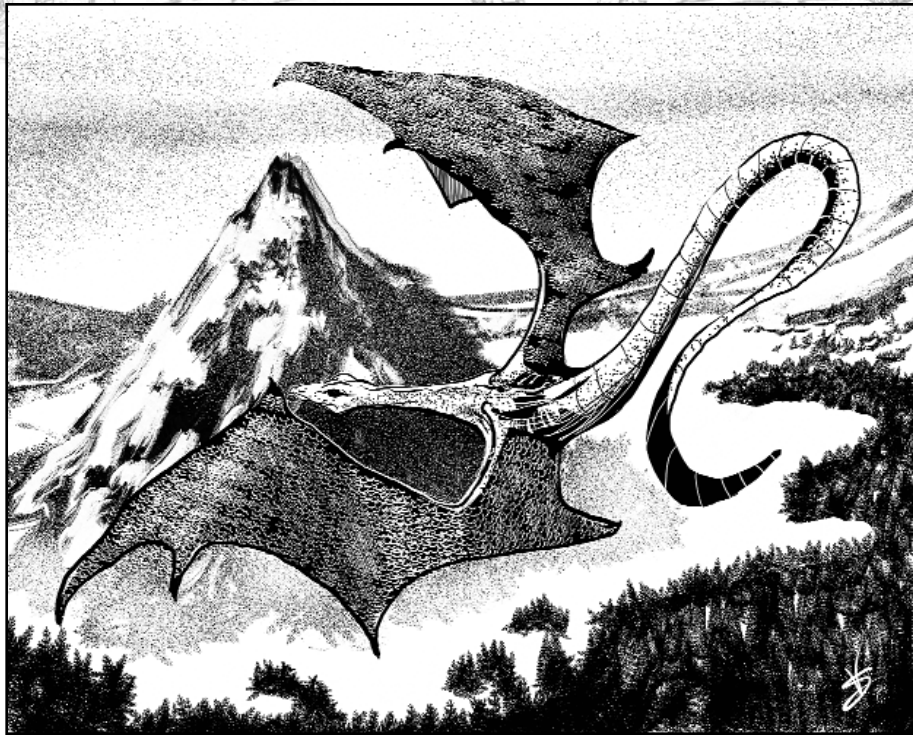

### Wind Dragons by Age

Age	Size	Hit Dice (hp)	Str	Dex	Con	Int	Wis	Cha	BAB/Grpl	Atk	Fort Save	Ref Save	Will Save	Breath Wpn. (DC)	Fright DC
Wyrmling	S	4d12+4 (30)	12	13	13	14	12	10	+4/+1	+6	+5	+5	+5	3d8 (18)	-
Very young	M	7d12+14 (59)	14	14	15	16	14	12	+7/+9	+9	+7	+7	+7	5d8 (20)	-
Young	M	10d12+20 (85)	16	15	15	18	14	12	+10/+13	+13	+9	+9	+9	7d8 (22)	-
Juvenile	L	13d12+39 (123)	18	16	15	20	16	14	+13/+21	+16	+10	+11	+11	9d8 (24)	-
Young adult	L	16d12+64 (168)	20	17	19	22	18	16	+16/+25	+20	+14	+13	+14	11d8 (26)	21
Adult	H	19d12+95 (218)	24	18	21	24	20	18	+19/+34	+24	+16	+15	+16	13d8 (28)	23
Mature adult	H	22d12+110 (253)	26	18	21	26	24	22	+22/+38	+28	+18	+17	+20	15d8 (30)	27
Old	H	25d12+150 (312)	28	19	23	28	26	24	+25/+42	+32	+20	+18	+22	17d8 (32)	29
Very old	H	28d12+168 (350)	30	19	23	30	30	28	+28/+46	+36	+22	+20	+26	19d8 (34)	33
Ancient	G	31d12+217 (418)	34	20	25	32	32	30	+31/+55	+39	+24	+22	+28	21d8 (36)	35
Wyrmling	G	34d12+272 (493)	38	20	27	34	34	32	+34/+60	+44	+27	+24	+31	23d8 (38)	38
Great wyrmling	G	37d12+370 (610)	42	21	31	36	38	34	+37/+65	+49	+30	+25	+34	25d8 (40)	40

### Wind Dragon Abilities by Age

Age	Speed	Initiative	AC	Special Abilities	CL	SR
Wyrmling	30 ft., fly 220 ft. (average)	+1	18 (+1 size, +1 Dex, +6 natural), touch 12, FF 17	Cold immunity	-	-
Very young	30 ft., fly 240 ft. (good)	+2	21 (+2 Dex, +9 natural), touch 12, FF 19		1st	-
Young	30 ft., fly 260 ft. (good)	+2	24 (+2 Dex, +12 natural), touch 12, FF 22		2nd	-
Juvenile	30 ft., fly 280 ft. (good)	+3	27 (-1 size, +3 Dex, +15 natural), touch 12, FF 24	Gust of wind	3rd	-
Young adult	30 ft., fly 300 ft. (good)	+3	30 (-1 size, +3 Dex, +18 natural), touch 12, FF 27	DR 5/magic	5th	24
Adult	30 ft., fly 320 ft. (perfect)	+4	33 (-2 size, +4 Dex, +21 natural), touch 12, FF 29	Control weather	7th	26
Mature adult	30 ft., fly 340 ft. (perfect)	+4	36 (-2 size, +4 Dex, +24 natural), touch 12, FF 32	DR 10/magic	9th	28
Old	30 ft., fly 360 ft. (perfect)	+4	39 (-2 size, +4 Dex, +27 natural), touch 12, FF 35	Haste	11th	30
Very old	30 ft., fly 380 ft. (perfect)	+4	42 (-2 size, +4 Dex, +30 natural), touch 12, FF 38	DR 15/magic	13th	32
Ancient	30 ft., fly 400 ft. (perfect)	+5	44 (-4 size, +5 Dex, +33 natural), touch 11, FF 39	Cyclone	15th	34
Wyrmling	30 ft., fly 420 ft. (perfect)	+5	47 (-4 size, +5 Dex, +36 natural), touch 11, FF 42	DR 20/magic	17th	36
Great wyrmling	30 ft., fly 440 ft. (perfect)	+5	50 (-4 size, +5 Dex, +39 natural), touch 11, FF 45	Summon air elementals	19th	38



hoards or have stolen from them.

Wind dragons occasionally wander to the surface world in order to explore it and seek out interesting new sites. Those beasts that have little experience with humanoids may sometimes approach a town or other settlement in friendship, but after a few days spent learning their ways the dragon may either grow bored and leave or lay waste to the place simply for the fun of it. Wind dragons have also been known to fly over the seas, looking for sailing ships to push about with their wind breath. To the dragons, this is an endlessly amusing game. Sometimes, a group of wind dragons gathers together a number of ships and tries to see who can push a ship the farthest or fastest with their wind breath. Needless to say, mariners rightfully fear wind dragons.

## Combat



In battle, wind dragons use their great speed and maneuverability to move behind their foes to attack with surprise. While strong in their own right, compared to other wyrms wind dragons fare poorly in physical combat. They prefer to rely on their breath weapon and magical abilities, using their speed to keep their distance from a target and using spells such as *cone of cold*, *power word: kill*, and other destructive magics to carry the day.



**Breath Weapon (Su):** A wind dragon has two different breath weapons. It may blast its enemies with a cone of cold energy (Reflex save for half damage) or it may generate near-hurricane winds. Its wind breath weapon takes the form of a cone. All creatures caught within this area must make a Reflex save or be knocked backward a number of feet equal to twice the dragon's hit dice. Flying creatures begin to fall and must make Reflex saves (DC 20) each round to pull out of their dive.



**Gust of Wind (Su):** Five times per day, a wind dragon may cast *gust of wind* as a sorcerer whose level equals its hit dice.



**Control Weather (Su):** Three times per day, a wind dragon may cast *control weather* as a sorcerer whose level equals its hit dice.



**Haste (Su):** The wind dragon's magical nature grants it incredibly swift reflexes. It may cast *haste* upon itself at will as a spell-like ability.



**Cyclone (Su):** Three times per day, a wind dragon may generate a whirlwind like those created by air elementals. The dragon creates the whirlwind with a full-round action. On subsequent rounds, the dragon may control the whirlwind with a free action. Treat the whirlwind as one created by an elder air elemental.



**Summon Air Elementals (Su):** Once per day, the wind dragon may summon 2d4 elder air elementals as a spell-like ability. The elementals remain on the prime plane for one hour and obey the wind dragon's commands to the best of their ability.

## Elf, Sky



Sky elves are an offshoot of the elven race that dwells amongst the clouds. Over the centuries, they have established the most powerful and secure kingdoms and realms of the skies.

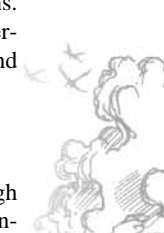

Sky elves look much like half-elves. The royal elven houses that initially migrated to the cloud realms were amongst the most warlike and aggressive of the elf clans. Centuries of combat against dragons, griffons, and other aerial marauders have left the sky elves much more warlike and physically tougher than their earthbound kin.

## Combat



Sky elves never rush into a fight. They are thorough planners and cautious fighters. Their settlements are in constant threat of destruction at the hands of rogue elementals, rampaging dragons, and other aerial threats. They fight in close ranks, using their longspears to set as many of their warriors as possible against the larger creatures they fight. As with surface elves, the sky elves are expert archers who rely on accurate missile fire to defeat opponents before they can come close enough to deal serious damage to a settlement or ship.

## Sergants



Sky elf sergeants tend to have wizard levels, giving them spellcasting abilities and familiars.

*Wizard Spells Prepared* (3/2, save DC = 12 + spell level): 0th—*acid splash*, *mage hand*, *ray of frost*; 1st—*feather fall*, *magic missile*.

**Hawk Familiar:** CR —; Tiny animal; HD 3 (effective); hp 5; Init +3; Spd. 10 ft., fly 60 ft. (average); AC 18, touch 15, flat-footed 15; Base Atk +2; Grp -8; Atk talons +5 melee (1d4-2); Space/Reach 2-1/2 ft./0 ft.; SQ alertness, improved evasion, share spells, empathic link; AL usually LG; SV Fort +2, Ref +5, Will +4; Str 6, Dex 17, Con 10, Int 6, Wis 14, Cha 6.

*Skills and feats:* Concentration +5, Listen +7, Spot +15; Weapon Finesse.

## Leaders



Like sergeants, sky elf leaders tend to have wizard levels, giving them spellcasting abilities and familiars.

*Wizard Spells Prepared* (4/3/2, save DC = 13 + spell level): 0th—*acid splash*, *daze*, *mage hand*, *ray of frost*; 1st—*feather fall*, *magic missile*, *shocking grasp*; 2nd—*spider climb*, *magic missile* [enlarged].

**Hawk Familiar:** CR —; Tiny animal; HD 6 (effective); hp 135; Init +3; Spd. 10 ft., fly 60 ft. (average); AC 19, touch 15, flat-footed 16; Base Atk +4; Grp -6; Atk talons +7 melee (1d4-2); Space/Reach 2-1/2 ft./0 ft.; SA deliver touch spells; SQ alertness, improved evasion, share spells, empathic link; AL usually LG; SV Fort +2, Ref +5, Will +5; Str 6, Dex 17, Con 10, Int 7, Wis 14, Cha 6.

*Skills and feats:* Climb +2, Concentration +6, Jump +4, Listen +7, Spot +14; Weapon Finesse.

	<p><b>Sky Elf Commoner</b> (War1) <b>Medium Humanoid (Elf)</b> 1d8 (4 hp) <b>Hit Dice:</b> <b>Initiative:</b> +1 <b>Speed:</b> 20 ft. (base 30 ft.) <b>AC:</b> 16 (+1 Dex, +5 chainmail), touch 11, flat-footed 15</p> <p><b>BAB/Grapple:</b> +1/+1 <b>Attack:</b> Longspear +1 melee (1d8) or longbow +3 ranged (1d8) <b>Full Attack:</b> Longspear +1 melee (1d8) or longbow +3 ranged (1d8) <b>Space/Reach:</b> 5 ft./5 ft. <b>Special Qualities:</b> Elven traits</p> <p><b>Saves:</b> Fort +2, Ref +1, Will +0 <b>Abilities:</b> Str 10, Dex 13, Con 10, Int 11, Wis 11, Cha 9 <b>Skills:</b> Listen +4, Ride +5, Spot +4</p> <p><b>Feats:</b> Weapon Focus (longbow)</p> <p><b>Environment:</b> Any aerial <b>Organization:</b> Company (2-4), squad (11-20 plus 2 3rd-level sergeants and 1 leader of 3rd-6th level), or band (30-100 plus 20% noncombatants plus 1 3rd-level sergeant per 10 adults, 5 5th-level lieutenants, and 3 7th-level captains)</p> <p><b>Challenge Rating:</b> 1/2 <b>Treasure:</b> Standard</p> <p><b>Alignment:</b> Usually lawful good <b>Advancement:</b> By character class <b>Level Advancement:</b> +0</p>	<p><b>Sky Elf Sergeant</b> (War2/Wiz1) <b>Medium Humanoid (Elf)</b> 2d8+1d4 (11 hp) <b>Hit Dice:</b> <b>Initiative:</b> +1 <b>Speed:</b> 30 ft. <b>AC:</b> 16 (+1 Dex, +5 +1 chain shirt), touch 11, flat-footed 15</p> <p><b>BAB/Grapple:</b> +2/+2 <b>Attack:</b> Longspear +2 melee (1d8) or longbow +4 ranged (1d8) <b>Full Attack:</b> Longspear +2 melee (1d8) or longbow +4 ranged (1d8) <b>Space/Reach:</b> 5 ft./5 ft. <b>Special Qualities:</b> Elven traits, spells, hawk familiar</p> <p><b>Saves:</b> Fort +3, Ref +1, Will +4 <b>Abilities:</b> Str 10, Dex 13, Con 10, Int 15, Wis 10, Cha 10 <b>Skills:</b> Concentration +5, Listen +7 (+9 when familiar is within 30 ft.), Spot +7 (+9 when familiar is within 30 ft.), +12 in bright light</p> <p><b>Feats:</b> Alertness (when familiar is within 30 ft.), Iron Will, Scribe Scroll, Weapon Focus (longbow)</p> <p><b>Environment:</b> Any aerial <b>Organization:</b> Squad (2 plus 11-20 sky elf commoners and 1 leader) or band (1 per 10 adults plus 30-100 commoners plus 20% noncombatants plus 5 5th-level lieutenants and 3 7th-level captains)</p> <p><b>Challenge Rating:</b> 2 <b>Treasure:</b> Standard (includes +1 chain shirt)</p> <p><b>Alignment:</b> Usually lawful good <b>Advancement:</b> By character class <b>Level Advancement:</b> +0</p>	<p><b>Sky Elf Leader</b> (War3/Wiz3) <b>Medium Humanoid (Elf)</b> 3d8+3d4+6 (27 hp) <b>Hit Dice:</b> <b>Initiative:</b> +2 <b>Speed:</b> 30 ft. <b>AC:</b> 19 (+2 Dex, +6 +2 chain shirt, ring of protection +1), touch 13, flat-footed 17</p> <p><b>BAB/Grapple:</b> +4/+5 <b>Attack:</b> Longspear +5 melee (1d8+1) or longbow +7 ranged (1d8) <b>Full Attack:</b> Longspear +5 melee (1d8+1) or longbow +7 ranged (1d8) <b>Space/Reach:</b> 5 ft./5 ft. <b>Special Qualities:</b> Elven traits, spells, hawk familiar</p> <p><b>Saves:</b> Fort +5, Ref +4, Will +7 <b>Abilities:</b> Str 12, Dex 14, Con 12, Int 16, Wis 12, Cha 11 <b>Skills:</b> Climb +5, Concentration +7, Jump +7, Listen +8 (+10 when familiar is within 30 ft.), Ride +6, Spellcraft +9, Spot +7 (+9 when familiar is within 30 ft.), +12 in bright light</p> <p><b>Feats:</b> Alertness (when familiar is within 30 ft.), Enlarge Spell, Iron Will, Scribe Scroll, Weapon Focus (longbow)</p> <p><b>Environment:</b> Any aerial <b>Organization:</b> Squad (1 plus 2 3rd-level sergeants plus 11-20 sky elf commoners)</p> <p><b>Challenge Rating:</b> 5 <b>Treasure:</b> Standard (includes +2 chain shirt and ring of protection +1)</p> <p><b>Alignment:</b> Usually lawful good <b>Advancement:</b> By character class <b>Level Advancement:</b> +0</p>
--	--	--	---

## FLOATING POLYP

A floating polyp is an intelligent, dangerous creature that preys on unsuspecting travelers, animals, and any other Medium or smaller creatures it encounters. The polyp appears as a large, round, fleshy balloon with a half-dozen long tentacles dangling from its lower half. These tentacles surround a small, toothy mouth. The polyp uses a series of gas chambers located in its body to control its altitude and direction. While slow compared to wings, this method of locomotion is extraordinarily quiet. The polyp generally glides silently through the air, pouncing on its enemies from ambush and overwhelming them before they have a chance to mount an effective counterattack.

Polyps are composed of nearly transparent, rubbery flesh. Though they are easily noticed under direct observation, they tend to blend in with the environment around them.





## Combat

In battle, the floating polyp floats several feet away from its target and lashes out with its stinging tentacles. The polyp generally floats above its prey, using its natural abilities to evade detection while waiting for an opportune moment to strike. Polyps are smart enough to focus their attacks on poorly armored or defenseless-looking targets.

**Improved Grab (Ex):** A floating polyp that hits a target with two or more of its stingers may initiate a grapple against its foe without drawing an attack of opportunity. The polyp uses two of its six stingers to hold its opponent.

**Strangulation (Ex):** While grappling an opponent, the floating polyp may strangle him with its tentacles. It may automatically deal damage with two of its tentacles against any foe it has in a grapple. It may attack as normal with the rest of its stingers, but may not use more than two of them to grasp or strangle a single opponent.

**Silent Flier (Ex):** The floating polyp's unique form of aerial movement allows it to glide silently through the air. It gains a +4 racial bonus to all Move Silently checks made while flying. This bonus is included in the skill total listed above.

**Translucence (Ex):** Floating polyps are partially transparent, making it difficult to spot them. A polyp gains a +4 racial bonus to all Hide checks. This bonus is included in the skill total listed above.

## Elder Polyp

Floating polyps grow larger as they age. The elder polyp below is the largest, most powerful example known. Growing to this size requires an exceptional specimen, so elder polyps are rare. They are usually encountered in small groups or as leaders of schools of smaller polyps.

	<b>Floating Polyp</b> <b>Medium Aberration</b>	<b>Elder Polyp</b> <b>Large Aberration</b>
<b>Hit Dice:</b>	3d8+6 (25 hp)	14d8+56 (119 hp)
<b>Initiative:</b>	+4	+3
<b>Speed:</b>	Fly 30 ft. (average)	Fly 30 ft. (average)
<b>AC:</b>	18 (+4 Dex, +4 natural), touch 14, flat-footed 14	18 (+3 Dex, +6 natural, -1 size), touch 12, flat-footed 15
<b>BAB/Grapple:</b>	+2/+4	+10/+20
<b>Attack:</b>	Stinger +4 melee (1d6)	Stinger +15 melee (1d8)
<b>Full Attack:</b>	6 stingers +4 melee (1d6)	6 stingers +15 melee (1d8)
<b>Space/Reach:</b>	5 ft./10 ft.	10 ft./15 ft.
<b>Special Attacks:</b>	Improved grab, strangulation	Improved grab, strangulation
<b>Special Qualities:</b>	Silent flier, translucence	Silent flier, translucence
<b>Saves:</b>	Fort +3, Ref +5, Will +5	Fort +8, Ref +7, Will +12
<b>Abilities:</b>	Str 14, Dex 18, Con 14, Int 10, Wis 14, Cha 10	Str 22, Dex 16, Con 18, Int 12, Wis 16, Cha 10
<b>Skills:</b>	Hide +16, Move Silently +16, Spot +10	Hide +24, Move Silently +24, Spot +20
<b>Environment:</b>	Any temperate, subterranean, or aerial	Any temperate, subterranean, or aerial
<b>Organization:</b>	Pair or school (3-12)	Solitary, pair, or school (1-2 plus 3-10 Medium size floating polyps)
<b>Challenge Rating:</b>	2	6
<b>Treasure:</b>	Standard	Standard
<b>Alignment:</b>	Usually neutral evil	Usually neutral evil
<b>Advancement:</b>	4-8 HD (Medium); 9-14 HD (Large)	-



# FLUTTER RAY

## Large Animal

<b>Hit Dice:</b>	5d8+8 (22 hp)
<b>Initiative:</b>	+1
<b>Speed:</b>	10 ft., fly 120 ft. (good)
<b>AC:</b>	17 (-1 size, +1 Dex, +3 natural, +4 deflection), touch 14, flat-footed 16
<b>BAB/Grapple:</b>	+3/+9
<b>Attack:</b>	Bite +4 melee (1d6+2)
<b>Full Attack:</b>	Bite +4 melee (1d6+2) and barbed tail +4 melee (1d10+2)
<b>Space/Reach:</b>	10 ft./5 ft. (10 or 15 ft. with tail)
<b>Special Qualities:</b>	Reverse gravity, stampede 2d6+2, low-light vision
<b>Saves:</b>	Fort +4, Ref +5, Will +4
<b>Abilities:</b>	Str 14, Dex 13, Con 10, Int 2, Wis 16, Cha 8
<b>Skills:</b>	Hide +1*, Spot +10
<b>Feats:</b>	Flyby Attack, Hover

---

<b>Environment:</b>	Any aerial
<b>Organization:</b>	Family (3-20), pack (21-100), herd (101-1,000), or migration (1,001-10,000)
<b>Challenge Rating:</b>	3
<b>Treasure:</b>	None
<b>Alignment:</b>	Always neutral
<b>Advancement:</b>	6-12 HD (Large), 13-24 HD (Huge)

Flutter rays are high-altitude herd animals. They float through the skies filtering air through their gaping mouths. In this manner they extract nutrition from microorganisms and minute particles. Sky serpents, cloud lurkers, and other aerial beasts prey upon flutter rays, which serve as a crucial link in the aerial ecosystem. Some flying races cultivate the creatures for meat and milk, while others hunt them for food. Their annual migration is a time of feasting for many avian cultures.

Flutter rays resemble manta rays with grossly distended abdomens and large, gaping mouths filled with strands of a flowing hair-like material. They have long tails covered in many tiny barbs. Their skin is powdery white or gray on the bottom and greenish-brown on top, such that they resemble clouds from below and ground from above. They are usually encountered in herds that can reach vast sizes. When surface dwellers see fast-moving clouds high in the sky, they may actually be looking at the largest herds of flutter rays.

Flutter rays give birth to live young, which can fly immediately. The creatures' flight does not depend on their wings, though they do use their wings for steering. Their flight comes from a supernatural ability to regulate gravity around themselves.

## Combat

Flutter rays are naturally non-aggressive. They usually initiate combat only to defend their young, and even then they do so only after uttering a warning squawk. However, they are excitable creatures with a tendency to stampede. Groups of flutter rays recently attacked by natural predators or hunters have been known to ferociously charge anything that comes near them until they have calmed down. They are thus considered dangerous by seasoned sky sailors, who prefer to avoid them, except when hunting them for meat. Their semi-annual migrations are considered extremely dangerous times, since a stampeding herd of 5,000 flutter rays is enough to knock almost any sky ship out of the air.

**Reverse Gravity (Su):** Flutter rays propel themselves through an innate ability to manipulate gravity. This effect extends only a few feet from their bodies, but the air turbulence it creates is enough to help protect them. They receive a +4 deflection bonus to armor class against all attacks. In addition, they can focus this power to defend themselves.

Once per day, a flutter ray can produce an effect identical to *reverse gravity* as cast by a 20th level sorcerer. Flutter rays are skilled at using this effect to disrupt the movement of flying creatures. Flyers hit by the effect are forced to make a Reflex save (DC 15) or lose their next move action as they struggle to control their flight in the newly reversed gravity. Creatures with low maneuverability may still be forced to move due to forward momentum, but they advance in a straight line with no control. This is a Wisdom-based save.

**Stampede (Ex):** In great numbers, panicked flutter rays are particularly dangerous. If they stampede, they fly madly away from whatever caused the stampede, paying no attention to whatever they crash into. A stampeding flutter ray will move directly into and through squares occupied by other creatures, possibly crashing into them in the process. Treat this as an overrun attack. Most flyers can move aside from at least one such attack but when faced by great herds of flutter rays that fill every square inch of available space, there is nowhere to step aside. Furthermore, sky ships simply cannot dodge these attacks. The flutter rays are panic-stricken and slam into whatever blocks their retreat. Unlike a normal overrun, this stampede inflicts 2d6+2 points of damage on whatever the flutter ray hits, and half as much on the flutter ray itself.

**Barbed Tail (Ex):** The flutter ray's barbed tail trails far behind it. It is a reach weapon that can harm creatures only 10 ft. or 15 ft. away from the flutter ray. Closer creatures cannot be hit by the barbs.

**Skills:** Flutter rays receive a +4 bonus to Hide checks due to their coloration.

# GOLEM, MIST

**Hit Dice:** 10d10+30 (74 hp)  
**Initiative:** +4  
**Speed:** Fly 60 ft. (good)  
**AC:** 18 (+4 Dex, +4 natural), touch 14, flat-footed 14  
**BAB/Grapple:** +7/+15  
**Attack:** Slam +11 melee (2d8+4)  
**Full Attack:** 2 slams +11 melee (2d8+4)  
**Space/Reach:** 5 ft./5 ft.  
**Special Qualities:** Construct, magic immunity, damage reduction 10/adamantine, invisibility  
**Saves:** Fort +3, Ref +8, Will +3  
**Abilities:** Str 18, Dex 20, Con -, Int -, Wis 10, Cha 1

---

**Environment:** Any  
**Organization:** Solitary or gang (2-4)  
**Challenge Rating:** 8  
**Treasure:** Standard  
**Alignment:** Always neutral  
**Advancement:** 4-8 HD (Medium); 9-14 HD (Large)

A mist golem is a magical construct built from raw materials harvested from the elemental plane of air. The golem is a cloud of light mist shaped into a vaguely humanoid form. A powerful matrix of elemental magic forms a field that keeps the mist golem's material bound together. When the golem moves, a shimmering field of golden energy encases it and keeps its form intact.

Mist golems stand roughly 8 feet tall. Though their form seems to shift slightly as they move, the energy field constructed to hold them together keeps their humanoid shape intact. Mist golems can fly through the air with ease. They are quite maneuverable and are used by wizards who keep towers high in the sky or must often contend with aerial attackers.

## Combat

In battle, the mist golem pummels its opponents with its powerful fists. While the golem's insubstantial inner material is too light and wispy to injure a foe, the energy field that encases it packs a tremendous amount of force. The golem's slam attacks deal force damage, allowing it to injure incorporeal or ethereal enemies.

With their invisibility ability, mist golems normally attempt to pounce on foes from ambush. Some wizards use these constructs as sentinels, ordering them to turn invisible at the first sign of intruders and stalk their prey. While mist golems lack intelligence of their own, they are normally given specific orders by their creators or owners that allow them to take advantage of their abilities.

**Invisibility (Su):** The mist golem may cast the spell *invisibility* upon itself as a 10th-level spellcaster three times per day. Normally, these golems use this spell to attack from surprise or stand a silent, invisible sentinel over a specific place or treasure.

**Construct:** Immune to mind-influencing effects, poison, disease, and similar effects. Critical hits, nonlethal damage, energy drain, death from massive damage, and ability score damage have no effect on a mist golem.

**Magic Immunity (Ex):** The mist golem is immune to most spells and spell-like effects. Electricity attacks injure them as normal, while *gust of wind* and *control weather* may be targeted directly against a mist golem. Both of those spells deal 1d6 damage per caster level (to a maximum of 15d6) to the mist golem.

## Construction

A mist golem requires raw materials harvested from the elemental plane of air. Collecting enough such material to build a mist golem requires five days of work spent on the elemental plane.

A mist golem costs 60,000 gp to create. Assembling its body requires a Spellcraft check (DC 25) and the spell *gust of wind*. The golem's builder must have at least 14 levels of arcane spellcasting ability. The ritual to complete the golem requires *wall of force*, *gust of wind*, *invisibility*, and *polymorph any object* and drains 1,000 XP.

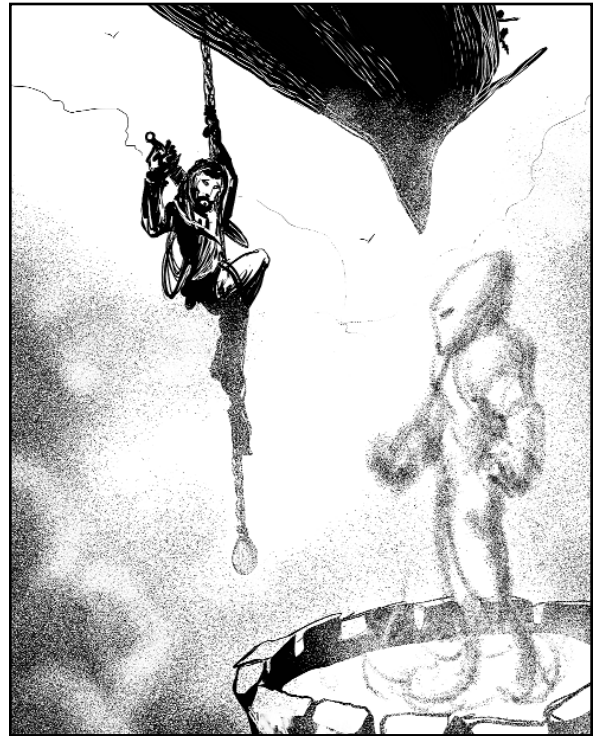



## INFUSED, AIR (TEMPLATE)

Some creatures become infused with raw elemental energy. Mundane creatures born on the elemental plane of air often exhibit infused qualities, as do those who spend a great deal of time around planar gates or which are caught in planar maelstroms. A few powerful elementals are able to alter their form (particularly genies with class levels as sorcerers or wizards), and they have been known to mate with mundane creatures, producing infused offspring.

Creatures infused with elemental energy from the plane of air appear completely normal, but exhibit strange powers that are especially useful in the aerial realms. In minor cases, they gain the ability to change into gaseous form (as the elementally infused heroic legacy, described on page 15). Intelligent humanoids can often unlock their native elemental powers with the elemental convert prestige class (described on page 19). The template presented here is used for unintelligent creatures that have been endowed with a substantial amount of elemental energy.

### SAMPLE AIR-INFUSED CREATURE: INFUSED DARKMANTLE

	<b>Infused Advanced Darkmantle</b> <b>Small Magical Beast (Air)</b>
<b>Hit Dice:</b>	3d10+3 (19 hp)
<b>Initiative:</b>	+4
<b>Speed:</b>	20 ft., fly 30 ft. (poor) or fly 40 ft. (average)
<b>AC:</b>	18 (+1 size, +6 natural, +1 Dex), touch 12, flat-footed 17
<b>BAB/Grapple:</b>	+3/+2
<b>Attack:</b>	Slam +5 melee (1d4+4)
<b>Full Attack:</b>	Slam +5 melee (1d4+4)
<b>Space/Reach:</b>	5 ft./5 ft.
<b>Special Attacks:</b>	Darkness, improved grab, constrict 1d4+4, air mastery, whirlwind (20 ft. tall, DC 14)
<b>Special Qualities:</b>	Blindsight 90 ft., gaseous form (DR 3/magic)
<b>Saves:</b>	Fort +4, Ref +4, Will +1
<b>Abilities:</b>	Str 16, Dex 12, Con 13, Int 2, Wis 10, Cha 10
<b>Skills:</b>	Hide +10, Listen +7, Spot +7
<b>Feats:</b>	Flyby Attack, Improved Initiative
<b>Environment:</b>	Any aerial
<b>Organization:</b>	Solitary, pair, clutch (3-9), or swarm (6-15)
<b>CR:</b>	2
<b>Treasure:</b>	None
<b>Alignment:</b>	Always neutral
<b>Advancement:</b>	4-6 HD (Medium), 7-12 HD (Large)
<b>Level Adjustment:</b>	-

This example uses an advanced 3 HD darkmantle as the base creature. The first infused darkmantles probably resulted from underground portals to the elemental plane of air. Since then they have multiplied and they are now a nuisance of the skies. They ambush sky ships with open decks. They're too small to threaten the sailors, but they often make off with small animals (such as the crew's dog, or any livestock on deck). Their ambushes take one of two forms. Sometimes they lurk high in the atmosphere, looking for sailing ships far below. Other times they assume gaseous form upon seeing a ship in the distance, then wait at the fringes of a cloud. Either way, as soon as the ship is near the infused darkmantle assumes its whirlwind form and descends upon the deck. It swirls about the target creatures, trying to sweep them into its winds. As soon as it catches a

creature, it resumes solid form (automatically inflicting a grab and causing constriction damage) and flies off with its prey.

An infused darkmantle has two modes of flight: its natural undulation of its "wings," which grants a speed of 30 ft. with poor maneuverability, or its supernatural ability to fly, which grants a speed of 40 ft. with average maneuverability.

### Combat

An infused darkmantle uses its darkness, improved grab, and constrict abilities just as a normal darkmantle. Its air mastery, whirlwind, and gaseous form abilities are exactly as the infused template, described below. Because of the unique synergies between its abilities, an infused darkmantle has the exceptional ability to automatically grapple any creature caught in its whirlwind form when it transforms out of the whirlwind. The creature receives no grapple check; it is automatically considered grappled and immediately takes constriction damage. However, remember that because of the darkmantle's Small size, its whirlwind is only strong enough to lift up a creature of size Tiny or smaller, even though in darkmantle form it can grapple up to Large size.

### Creating an Air-Infused Creature

"Infused" is an acquired or inherited template that can be added to any animal or magical beast (hereafter referred to as the base creature). An infused creature has the base creature's statistics and special abilities except as noted here.

**Size and Type:** The creature's type gains the "(air)" descriptor.

**Speed:** The infused creature gains the supernatural ability to fly. This is not a magical effect and is not contingent on the creature's anatomy or free motion; it can fly in an antimagic field and can fly even while hog-tied.

The infused creature's flight speed is equal to twice his land speed. Its maneuverability is average. If an elemental convert already has the ability to fly through another method, this does not supplant it; he simply gains another method by which to fly.

**Special Attacks:** An infused creature gains the following special attacks.

**Air Mastery (Ex):** Airborne creatures take a -1 penalty on attack and damage rolls against an infused creature. This includes creatures fighting from the backs of mounts or the decks of sky ships, but does not include creatures fighting from surfaces so large they are effectively land (such as

cloud cities or the backs of leviathans).

**Whirlwind (Su):** The infused creature can transform into a whirlwind, exactly as an air elemental. This can be done once per day and the creature can remain in that form for up to 1 round for every 2 HD or total class levels it has. In this form, the infused creature can move through the air or along a surface at its fly speed. The whirlwind is 5 feet wide at the base. For a Small creature, it can be up to 20 feet tall; for a Medium creature, it can be up to 30 feet tall; for a Large creature, up to 40 feet tall; and it can be up to 10 feet tall for each additional size increment.

The infused creature's movement while in whirlwind form does not provoke attacks of opportunity, even if he enters the space another creature occupies. Another creature might be caught in the whirlwind if it touches or enters the whirlwind, or if the infused creature moves into or through the creature's space.

Creatures one or more size categories smaller than the infused creature might take damage when caught in the whirlwind and may be lifted into the air. An affected creature must succeed on a Reflex save when it comes into contact with the whirlwind or take 1d6 damage. It must also succeed on a second Reflex save or be picked up bodily and held suspended in the powerful winds, automatically taking the indicated damage each round. A creature that can fly is allowed a Reflex save each round to escape the whirlwind. The creature still takes damage but can leave if the save is successful. The save DC is equal to 10 + the infused creature's HD plus character levels divided by two + its Strength modifier.

Creatures trapped in the whirlwind cannot move except to go where the infused creature carries them or to escape the whirlwind. Creatures caught in the whirlwind can otherwise act normally, but must succeed on a Concentration check

(DC 15 + spell level) to cast a spell. Creatures caught in the whirlwind take a -4 penalty to Dexterity and a -2 penalty on attack rolls. The infused creature can have only as many creatures trapped inside the whirlwind at one time as will fit inside the whirlwind's volume (generally two Medium creatures or one Large creature for a Large infused creature). The elemental can eject any carried creatures whenever it wishes, depositing them wherever the whirlwind happens to be.

If the whirlwind's base touches the ground, it creates a swirling cloud of debris. This cloud is centered on the infused creature and has a diameter of 5 feet (effectively covering only the whirlwind's square). The cloud obscures all vision, including darkvision, beyond 5 feet. Creatures 5 feet away have concealment, while those farther away have total concealment.

An infused creature in whirlwind form cannot make normal attacks, speak, or cast spells, and does not threaten the area around it.

**Special Qualities:** The infused creature gains the following special qualities.

**Gaseous Form (Su):** Once per day with great concentration, the creature can turn its body into a gaseous form. This is a spell-like ability similar to *gaseous form* with certain limitations. Only the creature's body transforms; equipment simply falls to the ground in a clattering heap. While in gaseous form the creature's damage reduction is only 3/magic. Transforming is a full-round action, and the gaseous form lasts only as long as the creature concentrates up to a maximum of ten minutes.

**Abilities:** An infused creature gains a +2 bonus to Dexterity.

**Challenge Rating:** Same as the base creature + 1. All other traits are as the base creature.

## KHASRI



### Medium Monstrous Humanoid

<b>Hit Dice:</b>	7d8+7 (38 hp)
<b>Initiative:</b>	+4
<b>Speed:</b>	30 ft., fly 80 ft. (perfect)
<b>Armor Class:</b>	16 (+4 Dex, +2 natural), touch 14, flat-footed 12
<b>BAB/Grapple:</b>	+7/+7
<b>Attack:</b>	Scimitar +7 melee (1d6/15-20) or claw +7 melee (1d3) or shortbow +11 ranged (+12 within 30 ft.) (1d6/x3)
<b>Full Attack:</b>	Scimitar +7 melee (1d6/15-20) or claw +7 melee (1d3) or shortbow +11 ranged (+12 within 30 ft.) (1d6/x3)
<b>Space/Reach:</b>	5 ft./5 ft.
<b>Special Attacks:</b>	Blood call
<b>Special Qualities:</b>	Low-light vision
<b>Saves:</b>	Fort +3, Ref +9, Will +6
<b>Abilities:</b>	Str 10, Dex 18, Con 13, Int 14, Wis 13, Cha 15
<b>Skills:</b>	Appraise +11, Concentrate +10, Hide +8, Listen +5, Move Silently +9, Search +9, Spot +10
<b>Feats:</b>	Far Shot, Improved Critical (scimitar), Point Blank Shot

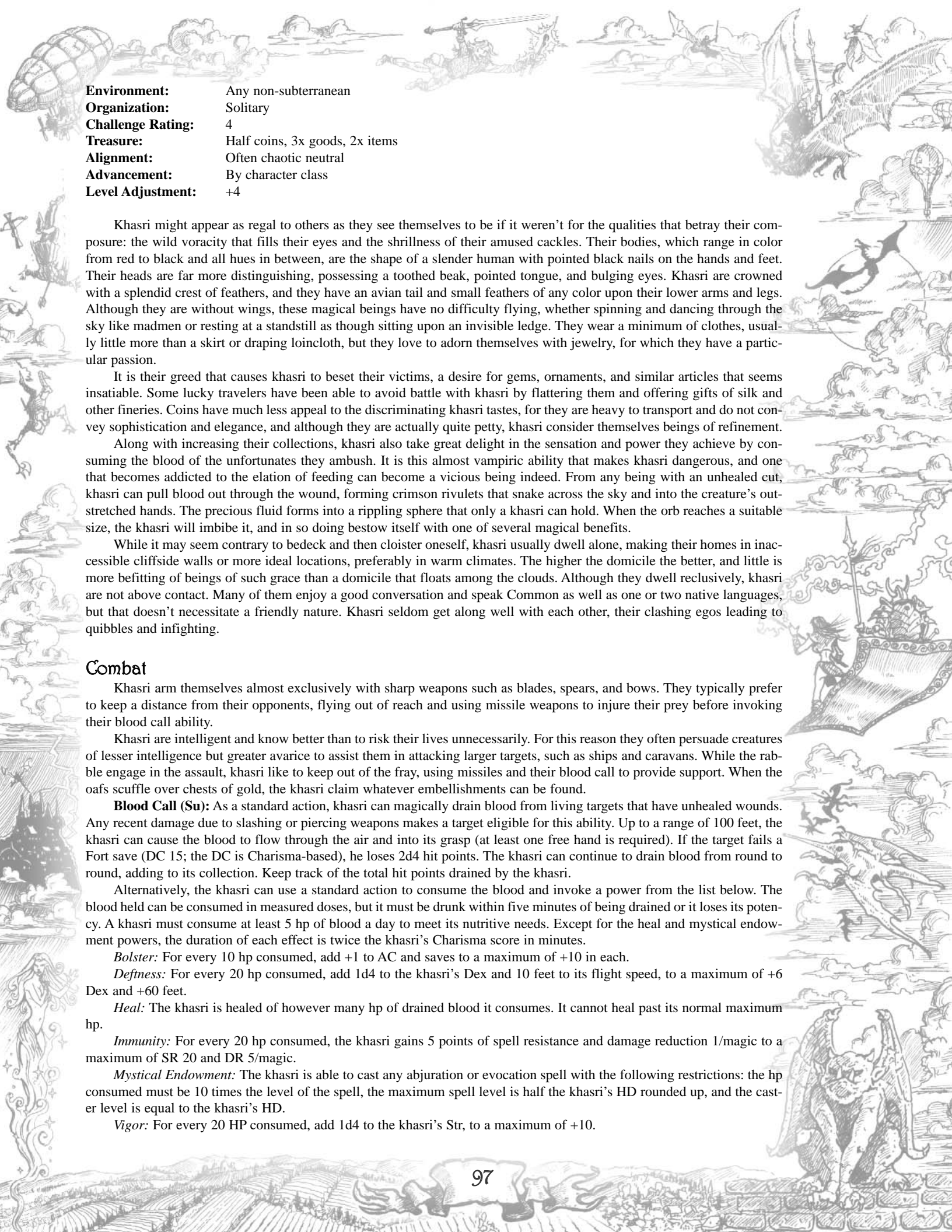

**Environment:** Any non-subterranean  
**Organization:** Solitary  
**Challenge Rating:** 4  
**Treasure:** Half coins, 3x goods, 2x items  
**Alignment:** Often chaotic neutral  
**Advancement:** By character class  
**Level Adjustment:** +4

Khasri might appear as regal to others as they see themselves to be if it weren't for the qualities that betray their composure: the wild voracity that fills their eyes and the shrillness of their amused cackles. Their bodies, which range in color from red to black and all hues in between, are the shape of a slender human with pointed black nails on the hands and feet. Their heads are far more distinguishing, possessing a toothed beak, pointed tongue, and bulging eyes. Khasri are crowned with a splendid crest of feathers, and they have an avian tail and small feathers of any color upon their lower arms and legs. Although they are without wings, these magical beings have no difficulty flying, whether spinning and dancing through the sky like madmen or resting at a standstill as though sitting upon an invisible ledge. They wear a minimum of clothes, usually little more than a skirt or draping loincloth, but they love to adorn themselves with jewelry, for which they have a particular passion.

It is their greed that causes khasri to beset their victims, a desire for gems, ornaments, and similar articles that seems insatiable. Some lucky travelers have been able to avoid battle with khasri by flattering them and offering gifts of silk and other fineries. Coins have much less appeal to the discriminating khasri tastes, for they are heavy to transport and do not convey sophistication and elegance, and although they are actually quite petty, khasri consider themselves beings of refinement.

Along with increasing their collections, khasri also take great delight in the sensation and power they achieve by consuming the blood of the unfortunates they ambush. It is this almost vampiric ability that makes khasri dangerous, and one that becomes addicted to the elation of feeding can become a vicious being indeed. From any being with an unhealed cut, khasri can pull blood out through the wound, forming crimson rivulets that snake across the sky and into the creature's outstretched hands. The precious fluid forms into a rippling sphere that only a khasri can hold. When the orb reaches a suitable size, the khasri will imbibe it, and in so doing bestow itself with one of several magical benefits.

While it may seem contrary to bedeck and then cloister oneself, khasri usually dwell alone, making their homes in inaccessible cliffside walls or more ideal locations, preferably in warm climates. The higher the domicile the better, and little is more befitting of beings of such grace than a domicile that floats among the clouds. Although they dwell reclusively, khasri are not above contact. Many of them enjoy a good conversation and speak Common as well as one or two native languages, but that doesn't necessitate a friendly nature. Khasri seldom get along well with each other, their clashing egos leading to quibbles and infighting.

## Combat

Khasri arm themselves almost exclusively with sharp weapons such as blades, spears, and bows. They typically prefer to keep a distance from their opponents, flying out of reach and using missile weapons to injure their prey before invoking their blood call ability.

Khasri are intelligent and know better than to risk their lives unnecessarily. For this reason they often persuade creatures of lesser intelligence but greater avarice to assist them in attacking larger targets, such as ships and caravans. While the rabble engage in the assault, khasri like to keep out of the fray, using missiles and their blood call to provide support. When the oafs scuffle over chests of gold, the khasri claim whatever embellishments can be found.

**Blood Call (Su):** As a standard action, khasri can magically drain blood from living targets that have unhealed wounds. Any recent damage due to slashing or piercing weapons makes a target eligible for this ability. Up to a range of 100 feet, the khasri can cause the blood to flow through the air and into its grasp (at least one free hand is required). If the target fails a Fort save (DC 15; the DC is Charisma-based), he loses 2d4 hit points. The khasri can continue to drain blood from round to round, adding to its collection. Keep track of the total hit points drained by the khasri.

Alternatively, the khasri can use a standard action to consume the blood and invoke a power from the list below. The blood held can be consumed in measured doses, but it must be drunk within five minutes of being drained or it loses its potency. A khasri must consume at least 5 hp of blood a day to meet its nutritive needs. Except for the heal and mystical endowment powers, the duration of each effect is twice the khasri's Charisma score in minutes.

**Bolster:** For every 10 hp consumed, add +1 to AC and saves to a maximum of +10 in each.

**Deftness:** For every 20 hp consumed, add 1d4 to the khasri's Dex and 10 feet to its flight speed, to a maximum of +6 Dex and +60 feet.

**Heal:** The khasri is healed of however many hp of drained blood it consumes. It cannot heal past its normal maximum hp.

**Immunity:** For every 20 hp consumed, the khasri gains 5 points of spell resistance and damage reduction 1/magic to a maximum of SR 20 and DR 5/magic.

**Mystical Endowment:** The khasri is able to cast any abjuration or evocation spell with the following restrictions: the hp consumed must be 10 times the level of the spell, the maximum spell level is half the khasri's HD rounded up, and the caster level is equal to the khasri's HD.

**Vigor:** For every 20 HP consumed, add 1d4 to the khasri's Str, to a maximum of +10.



# LEVIATHAN

<b>Hit Dice:</b>	32d10+288 (464 hp)
<b>Initiative:</b>	-1
<b>Speed:</b>	Fly 20 ft. (clumsy)
<b>AC:</b>	14 (-8 size, -1 Dex, +13 natural), touch 1, flat-footed 14
<b>BAB/Grapple:</b>	+32/+64
<b>Attack:</b>	+40 bite (4d20+16)
<b>Full Attack:</b>	+40 bite (4d20+16)
<b>Space/Reach:</b>	120 ft./15 ft.
<b>Special Attacks:</b>	Improved grab, swallow whole
<b>Special Qualities:</b>	Supernatural buoyancy, SR 25, gate
<b>Saves:</b>	Fort +25, Ref +17, Will +14
<b>Abilities:</b>	Str 43, Dex 8, Con 28, Int 6, Wis 18, Cha 12
<b>Skills:</b>	Listen +17, Sense Motive +14, Spot +17, Wilderness Lore +15
<b>Feats:</b>	Alertness, Cleave, Endurance, Great Cleave, Improved Bull Rush, Power Attack, Sunder

<b>Environment:</b>	Any aerial
<b>Organization:</b>	Solitary or pod (2-5)
<b>Challenge Rating:</b>	14
<b>Treasure:</b>	None
<b>Alignment:</b>	Always neutral
<b>Advancement:</b>	33-128 HD (Colossal)
<b>Level Adjustment:</b>	-

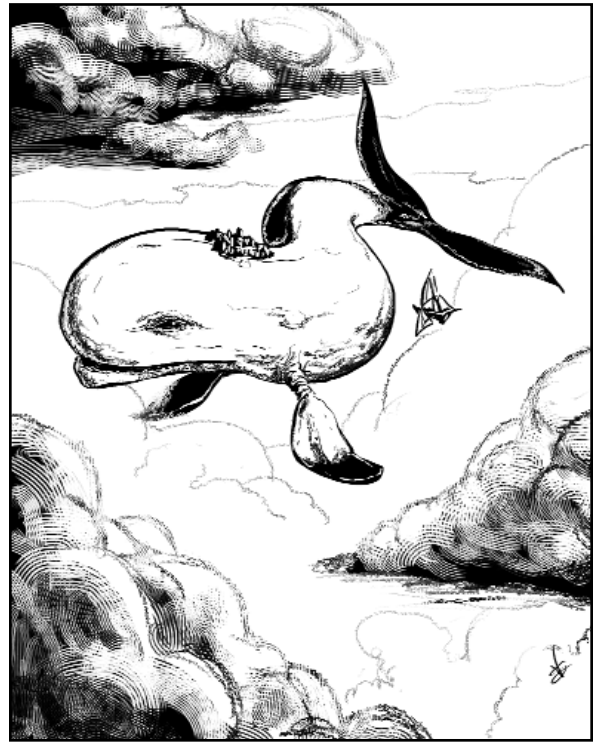

Commonly known as sky whales, the monstrous leviathans are the undisputed kings of the air lanes. These great flying beasts measure over 100 feet in length, though luckily for the denizens of the sky they are peaceful, gentle creatures that spend much of their time in a deep hibernation. Leviathans are natives of the elemental plane of air forced to travel to the prime plane in search of food and water. Leviathans drift through the air, drawing energy from the sun and absorbing water from the air to sustain themselves. These beasts rarely make any sudden moves. The food and energy they collect goes towards sustaining their life systems and leaves little excess for any sudden motions. Leviathans remain within a sleep-like state unless attacked, at which point they roar into action using their great jaws to crush and swallow attackers. Only a fool attacks a leviathan, and as these creatures rarely make any sudden moves humanoids sometimes establish settlements upon their backs. Powerful druids sometimes form an alliance with a leviathan and direct the creature to carry the druid and his community.

## Combat

In battle, leviathans rely on their great bulk and powerful bite to defeat enemies. However, few creatures bother attacking leviathans. These peaceful creatures do not gather treasure and their flesh is unpalatable. Their bones are highly magical and can float through the air, but they are too dense to make use of in constructing sky ships.

**Supernatural Buoyancy (Su):** As magical creatures from the elemental plane of air, leviathans are capable of holding their great bulk aloft and directing their movement through the pure force of the elemental magic that suffuses their forms. This energy is focused in the creature's skeleton. When a leviathan dies, its bones continue to float through the air for decades afterward.

**Gate (Su):** Once per day a leviathan may open a gate to the elemental plane of air or to the prime plane, depending on its current location.

**Improved Grab (Ex):** To use this ability, the leviathan must hit with its bite attack. If it gets hold, it may attempt to swallow the opponent.

**Swallow Whole (Ex):** A leviathan can attempt to swallow a Gargantuan or smaller creature by making a successful grapple check. A leviathan can use its Cleave or Great Cleave feat to bite, grab, and swallow an opponent.

A swallowed creature takes 2d20+16 points of crushing damage and 16 points of acid damage per round in the leviathan's gizzard. A swallowed creature can cut its way out by using claws or a Small or Tiny slashing weapon to deal 50 points of damage to the gizzard (AC 15). Once the creature exits, muscular contractions and swelling make the exit unusable. Other creatures must cut their way out on their own. Several creatures may work together to cut their way out. The leviathan's gullet is large enough that Medium size or smaller creatures may work together in order to hack their way out. If a group works together to exit, one creature may make attacks while the rest use the aid another action to improve his attack roll. Once the opening is made, the attacking creature and all those aiding him may escape.

## LIMMER GAFF

<b>Hit Dice:</b>	4d8+4 (22 hp)
<b>Initiative:</b>	+7
<b>Speed:</b>	30 ft., climb 15 ft.
<b>Armor Class:</b>	17 (+3 Dex, +4 natural), touch 13, flat-footed 14
<b>BAB/Grapple:</b>	+4/+6
<b>Attack:</b>	Claw +4 melee (1d6+2)
<b>Full Attack:</b>	2 claws +4 melee (1d6+2)
<b>Space/Reach:</b>	5 ft./5 ft.
<b>Special Attacks:</b>	Poison gas
<b>Special Qualities:</b>	Ethereal vision, ethereal revelation
<b>Saves:</b>	Fort +2, Ref +4, Will +5
<b>Abilities:</b>	Str 15, Dex 17, Con 12, Int 6, Wis 12, Cha 9
<b>Skills:</b>	Climb +15, Hide +4, Listen +5, Move Silently +5, Spot +8
<b>Feats:</b>	Alertness, Improved Initiative
<b>Environment:</b>	Any non-arctic aerial
<b>Organization:</b>	Solitary or hive (2-10)
<b>Challenge Rating:</b>	3
<b>Treasure:</b>	None
<b>Alignment:</b>	Always neutral evil
<b>Advancement:</b>	5-7 HD (Medium), 8-12 HD (Large)
<b>Level Adjustment:</b>	+2 (cohort)



Limmer gaffs are creatures of unsettling presence and obviously malicious intent. They make no attempts to veil their lethal nature with disguise of form or pretense of friendship. One glance at a limmer gaff's face – a concave countenance with a dominating mandible set in the middle and six eyes, three above and three below – is usually enough to impress upon the onlooker that these are not beings of social grace. Individuals that have used magical means to understand the crude, crepitating language of limmer gaffs have found them to be simpleminded murderers that speak of little but their hunger, what victims would best sate that hunger, and what primitive strategy should be used to catch those victims.

Limmer gaffs bear a slight resemblance to insects in so much as they have bulging abdomens and six appendages that allow them to crawl and climb about with ease. Four of the limbs support the abdomen while the remaining two extend from a raised fore-body. These last two are jointed much like those of a humanoid and even have five crude, clawish fingers. These evenly spaced digits include two thumbs, but the most eye-catching of the group is the middle finger, which far exceeds the others in size. It extends into a large hook and functions as the limmer gaff's foremost tool, whether used for slashing and catching in a predatory assault or for scuttling about upon the vessels they waylay or upon the shimmering, crystalline supports that appear about them.

An unusual characteristic of limmer gaffs is that their very presence causes matter in the ethereal plane to be drawn into the material plane. An individual peering at the world from the supposed safety of the ethereal realm may well find himself exposed and beset, for limmer gaffs see all that is in both planes and neither is safe from them.

It is this dimensional displacement that allows limmer gaffs to live in their most curious fashion, for although they cannot fly, their favored habitation is the open sky. Within the ethereal plane there exists a growth called gossam shard that resembles at once vine, fungus, and mineral. It expands in all directions like haphazard scaffolding with gaps ranging from four to a dozen or more feet in breadth. Limmer gaffs can climb on this substance, retaining their hold even while on the material plane. Individual growths of gossam shard can range in size from a sprouting twig to several miles in span, even so large that multiple limmer gaff hives can live on one and not come into regular contact with each other. Although gossam shard branches are seldom more than three inches in diameter and any significant amount of pressure placed upon them causes a sound like breaking glass, they're actually quite strong and most limbs can support the weight of several robust individuals. Should the limmer gaff that summoned a gossam shard move away from it or perish, the scintillating blue lattice will return to the ethereal plane, dropping all that sat upon it.

### Combat

One limmer gaff would be bad enough, but they almost always attack in numbers. Their speed upon gossam shard and impressive leaps allow them to quickly board ships, while flying creatures caught unawares by an ambushing hive may very well become entrapped within a web of gossam shard.

Limmer gaffs lie in wait when there is cover to be found, or they prowl about the skies searching for a target. They are

cunning enough to seek optimal angles of approach, such as the direction of the sun or from the underside of an airship. Once their quarry is in range, they vigorously set upon it with their swinging hooks and periodically puff noxious gas from their abdomens. If their prey are small in number, they will slaughter all and devour the hapless lot where they are felled. Against larger groups, limmer gaffs adopt a more mobile approach, subduing a few victims and carrying them off to a more secluded locale. Here the victors can eat in leisure or hang their catch from the gossam shard like so much sausage for later consumption.

Because gossam shard occupies most of ethereal space, limmer gaffs can climb about the material plane at will. They can walk through the air by climbing on gossam shard. A limmer gaff is always considered to exist in both the ethereal and material plane at the same time.

**Ethereal Vision (Su):** Limmer gaffs can see into the ethereal plane naturally.

**Ethereal Revelation (Su):** All items and entities in the ethereal plane that within 20 feet of a living limmer gaff are brought forth into the material plane. Should a distance exceeding 20 feet come between the items/individuals and the limmer gaff, they will return to the ethereal plane again. They will also be returned if all limmer gaffs within the 20-foot radius are slain.

**Poison Gas (Ex):** When limmer gaffs are agitated or excited, they tend to puff purple gas from small holes in their abdomens. Every round that they are in combat or a similarly stressfully condition, there is a 20% chance that a limmer gaff will eject a cloud that surrounds it (10 foot radius). Expelling the gas does not count as an action if it occurs by chance, although limmer gaffs can intentionally release the gas as a standard action. The poison makes its victims woozy. All non-limmer gaffs within the cloud must make a Fort save (DC 14) or suffer the effects (primary: 1d6 Dex, secondary: 1d2 Con). In open air a gas cloud will clear in three rounds or less if windy. The effects of multiple clouds do not stack. An individual who makes his save does not need to check again for 24 hours.

**Skills:** Limmer gaffs receive a racial bonus of +3 to Spot and +13 to Climb. They can always choose to take 10 on a Climb check, even if rushed or threatened.

## LYCANTHROPE: WEREHAWK (TEMPLATE)

	<b>Sky Elf Form</b> <b>Medium Humanoid (War1)</b> <b>(Elf, Shapechanger)</b>	<b>Dire Hawk Form</b> <b>Large Humanoid</b> <b>(Elf, Shapechanger)</b>	<b>Hybrid Form</b> <b>Medium Humanoid</b> <b>(Elf, Shapechanger)</b>
<b>Hit Dice:</b>	1d8 plus 4d8+8 (30 hp)	1d8 plus 4d8+8 (30 hp)	1d8 plus 4d8+8 (30 hp)
<b>Initiative:</b>	+1	+6	+6
<b>Speed:</b>	30 ft.	10 ft., fly 60 ft. (average)	30 ft.
<b>AC:</b>	18 (+1 Dex, +2 natural, +5 chainmail), touch 11, flat-footed 17	19 (+6 Dex, +4 natural, -1 size), touch 15, flat-footed 13	20 (+6 Dex, +4 natural), touch 16, flat-footed 14
<b>BAB/Grapple:</b>	+4/+4	+4/+11	+4/+7
<b>Attack:</b>	Longspear +4 melee (1d8) or longbow +6 ranged (1d8)	Claw +6 melee (1d6+3)	Claw +7 melee (1d4+3)
<b>Full Attack:</b>	Longspear +4 melee (1d8) or longbow +6 ranged (1d8)	2 claws +6 melee (1d6+3) and bite +1 melee (1d8+3)	2 claws +7 melee (1d4+3) and bite +2 melee (1d6+3)
<b>Space/Reach:</b>	5 ft./5 ft.	10 ft./5 ft.	5 ft./5 ft.
<b>Special Attacks:</b>	–	Curse of lycanthropy	Curse of lycanthropy
<b>Special Qualities:</b>	Elven traits, alternate form, hawk empathy, low-light vision	Elven traits, alternate form, DR 10/silver, hawk empathy, low-light vision	Elven traits, alternate form, DR 10/silver, hawk empathy, low-light vision
<b>Saves:</b>	Fort +6, Ref +2, Will +7	Fort +7, Ref +7, Will +7	Fort +7, Ref +7, Will +7
<b>Abilities:</b>	Str 10, Dex 13, Con 10, Int 11, Wis 13, Cha 9	Str 16, Dex 23, Con 12, Int 11, Wis 13, Cha 9	Str 16, Dex 23, Con 12, Int 11, Wis 13, Cha 9
<b>Skills:</b>	Climb +4, Jump +4, Listen +7, Spot +11	Climb +7, Jump +7, Listen +7, Spot +11 (same as human form)	Climb +7, Jump +7, Listen +7, Spot +11 (same as human form)
<b>Feats:</b>	Alertness, Flyby Attack, Iron Will, Weapon Focus (longbow)		
<b>Environment:</b>	Any aerial	Any aerial	Any aerial
<b>Organization:</b>	Solitary or pair	(same as human form)	(same as human form)
<b>Challenge Rating:</b>	4	4	4
<b>Treasure:</b>	Standard	Standard	Standard
<b>Alignment:</b>	Usually chaotic neutral	Usually chaotic neutral	Usually chaotic neutral
<b>Advancement:</b>	By character class	By character class	By character class
<b>Level Adjustment:</b>	+3	+3	+3



Wolves are not common in the sky lanes, but hawks are. The werewolf is a rare breed of lycanthrope that lives its life with a deep secret. The freedom of assuming hawk form offers unprecedented access to the airways, and many werewolves use this to their advantage. Those who come down with this affliction usually find a way to benefit from their newfound powers of flight, and many become powerful adventurers or guild heads.

In a few cultures – particularly among avians and in some of the wilder sky elf zones – becoming a werewolf is considered a mark of divine favor. The ability to transform into a hawk is so useful or symbolic to these peoples that they bow down to those who can. In a distant sky elf farming settlement known as Hawkfeather, being cursed with werewolf lycanthropy is a prerequisite to rising in the local order of clerics. All Hawkfeather clerics of Laelus above 3rd level are werewolves.

## Combat

Werewolves can assume a hybrid form as well as an animal form. In animal form, they can fly and use their Flyby Attack feat just as normal dire hawks do. In hybrid form, a werewolf relies on its claws.

**Alternate Form (Su):** A werewolf can assume a bipedal hybrid form or the form of a dire hawk.

**Curse of Lycanthropy (Su):** Any humanoid or giant hit by a werewolf's bite attack in animal or hybrid form must succeed on a DC 15 Fortitude save or contract lycanthropy.

**Hawk Empathy (Ex):** Communicate with hawks and dire hawks, and +4 racial bonus on Charisma-based checks against hawks and dire hawks.

**Skills:** A werewolf receives a +4 bonus to Spot checks in all forms.

## Creating a Werewolf

The werewolf template is applied per the usual lycanthrope template, as described in the MM. Werewolves have the following modifications.

Name	Animal Form	Animal or Hybrid Form Ability Modifiers	Preferred Alignment
Werewolf	Dire hawk	Str +6, Dex +10, Con +2	Chaotic neutral

## SAMPLE WEREWOLF: SKY ELF PRIEST OF LAELUS

Certain sky elves revere werewolves as sacred embodiments of Laelus' will that they should rule the clouds. This is not the church's official doctrine and such followers of Laelus are considered deviants in cosmopolitan cloud cities like Sellaine. Nonetheless, the cult does survive on the fringes of sky elf society. Many of its members interact regularly with clerics of the more orthodox church, who have little idea of their brethren's true nature.

The werewolf priest presented here (with stats on the following page) is based on a 7th-level cleric of Laelus and natural lycanthrope, using the base ability scores Str 12, Dex 14, Con 14, Int 10, Wis 16, Cha 10.

## Combat

The werewolf priest can assume a hybrid form as well as an animal form. In animal form, he can fly and use the Flyby Attack feat just as normal dire hawks do. In hybrid form, he relies on its claws, though he is capable of also wielding weapons.

**Alternate Form (Su):** The werewolf priest can assume a bipedal hybrid form or the form of a dire hawk.

**Curse of Lycanthropy (Su):** Any humanoid or giant hit by the werewolf priest's bite attack in animal or hybrid form must succeed on a DC 15 Fortitude save or contract lycanthropy.

**Hawk Empathy (Ex):** Communicate with hawks and dire hawks, and +4 racial bonus on Charisma-based checks against hawks and dire hawks.

**Skills:** A werewolf receives a +4 bonus to Spot checks in all forms.

**Possessions:** +2 flail, +2 sunbright chainmail armor, *potion of cure serious wounds*, *potion of cure moderate wounds*, masterwork longbow, *potion of greater magic fang +1*, *potion of cat's grace*, *bag of holding (type 1)*, *amulet of natural armor +1*. When in dire hawk form, the werewolf priest keeps most of his equipment in the *bag of holding*, except for the *amulet of natural armor +1* (which he can still wear in any form). The strap of the *bag of holding* is specially designed to be worn by the werewolf priest in any form. (Different werewolf priests may have different equipment.)

**Cleric Domains:** Air, Sun.

**Cleric Spells Prepared** (6/5+1/4+1/3+1/2+1; save DC 14 + spell level): 0—*create water*, *cure minor wounds*, *guidance*, *inflict minor wounds*, *resistance*, *virtue*; 1st—*command*, *cure light wounds*, *divine favor*, *entropic shield*, *obscuring mist\**, *sanctuary*; 2nd—*bull's strength*, *cure moderate wounds*, *hold person x2*, *wind wall\**; 3rd—*cure serious wounds*, *prayer*, *searing light\**, *wind wall\**; 4th—*fire shield\**, *freedom of movement*, *sending*.

\* Domain spell.



**Hit Dice:**  
**Initiative:**  
**Speed:**  
**AC:**

**Werehawk Priest,  
Sky Elf Form  
Medium Humanoid (Clr7)  
(Elf, Shapechanger)**

7d8+14 plus 4d8+12 (75 hp)  
+2  
30 ft.  
22 (+2 Dex, +3 natural  
(includes *amulet of natural  
armor +1*), +7 +2  
*sunbright chainmail  
armor*), touch 12,  
flat-footed 20

**BAB/Grapple:**  
**Attack:**

+8/+9  
+2 *flail* +11 melee  
(1d8+3) or masterwork  
longbow +11 ranged (1d8)

**Full Attack:**

+2 *flail* +11 melee  
(1d8+3) or masterwork  
longbow +11 ranged (1d8)

**Space/Reach:**

5 ft./5 ft.

**Special Attacks:**

Turn undead, spells

**Special Qualities:**

Elven traits, alternate form,  
hawk empathy, low-light  
vision

**Saves:**

Fort +11, Ref +5, Will +15

**Abilities:**

Str 12, Dex 14, Con 14,  
Int 10, Wis 18, Cha 10

**Skills:**

Concentration +12,  
Heal +9, Listen +15,  
Spot +10

**Feats:**

Alertness, Brew Potion,  
Combat Casting, Flyby  
Attack, Improved Turning,  
Iron Will

**Werehawk Priest,  
Dire Hawk Form  
Large Humanoid  
(Elf, Shapechanger)**

7d8+14 plus 4d8+12 (75 hp)  
+7  
10 ft., fly 60 ft. (average)  
21 (+7 Dex, +5 natural  
(includes *amulet of natural  
armor +1*), -1 size),  
touch 16, flat-footed 14

+8/+16

Claw +11 melee (1d6+4)

2 claws +11 melee (1d6+4)  
and bite +6 melee (1d8+4)

10 ft./5 ft.

Curse of lycanthropy  
Elven traits, alternate form,  
DR 10/silver, hawk  
empathy, low-light  
vision

Fort +12, Ref +10, Will +15

Str 18, Dex 24, Con 16,  
Int 10, Wis 18, Cha 10

Concentration +13,  
Heal +9, Listen +15,  
Spot +10

(same as human form)

**Werehawk Priest,  
Hybrid Form  
Medium Humanoid  
(Elf, Shapechanger)**

7d8+14 plus 4d8+12 (75 hp)  
+7  
30 ft.  
21 (+7 Dex, +5 natural  
(includes *amulet of  
natural armor +1*)), touch  
17, flat-footed 15

+8/+12

Claw +12 melee (1d4+4)

2 claws +12 melee  
(1d4+4) and bite +7 melee  
(1d6+4)

5 ft./5 ft.

Curse of lycanthropy  
Elven traits, alternate  
form, DR 10/silver, hawk  
empathy, low-light  
vision

Fort +12, Ref +10, Will +15

Str 18, Dex 24, Con 16,  
Int 10, Wis 18, Cha 10

Concentration +13,  
Heal +9, Listen +15,  
Spot +10

(same as human form)

**Environment:**

Any aerial

**Organization:**

Solitary or flock (1 plus  
1-2 3rd-level clerics plus  
2-5 1st-level adepts)

Any aerial

(same as human form)

Any aerial

(same as human form)

**Challenge Rating:**

10

10

10

**Treasure:**

Standard

Standard

Standard

**Alignment:**

Lawful good

Lawful good

Lawful good

**Advancement:**

By character class

By character class

By character class

**Level Adjustment:**

+3

+3

+3

## NOCTILIUS BAT

Noctilius bats are a particularly large version of the dire bat bred and used as mounts by the black orcs of Noctilius Point. The bats are bonded to their riders and voluntarily return to roost, so they are free to hunt at their whim whenever they are not on a mission. As such they can be encountered without riders. Surface-dwellers who live near Noctilius Point encounter them most often in this manner.

In the sky lanes, however, the Noctilius bat is almost always encountered with an orc rider. These nasty orc pirates terrorize small sky ships. They leap from their bats and pillage the ship while the bats dive-bomb whoever comes above-deck to fight the orcs. Once the orcs have fought their way to the cargo hold, they bring the valuables above-deck, load them on their bats, and fly away at top speed.

A Noctilius bat has a wingspan of 20 ft. and weighs from 500 to 600 pounds.



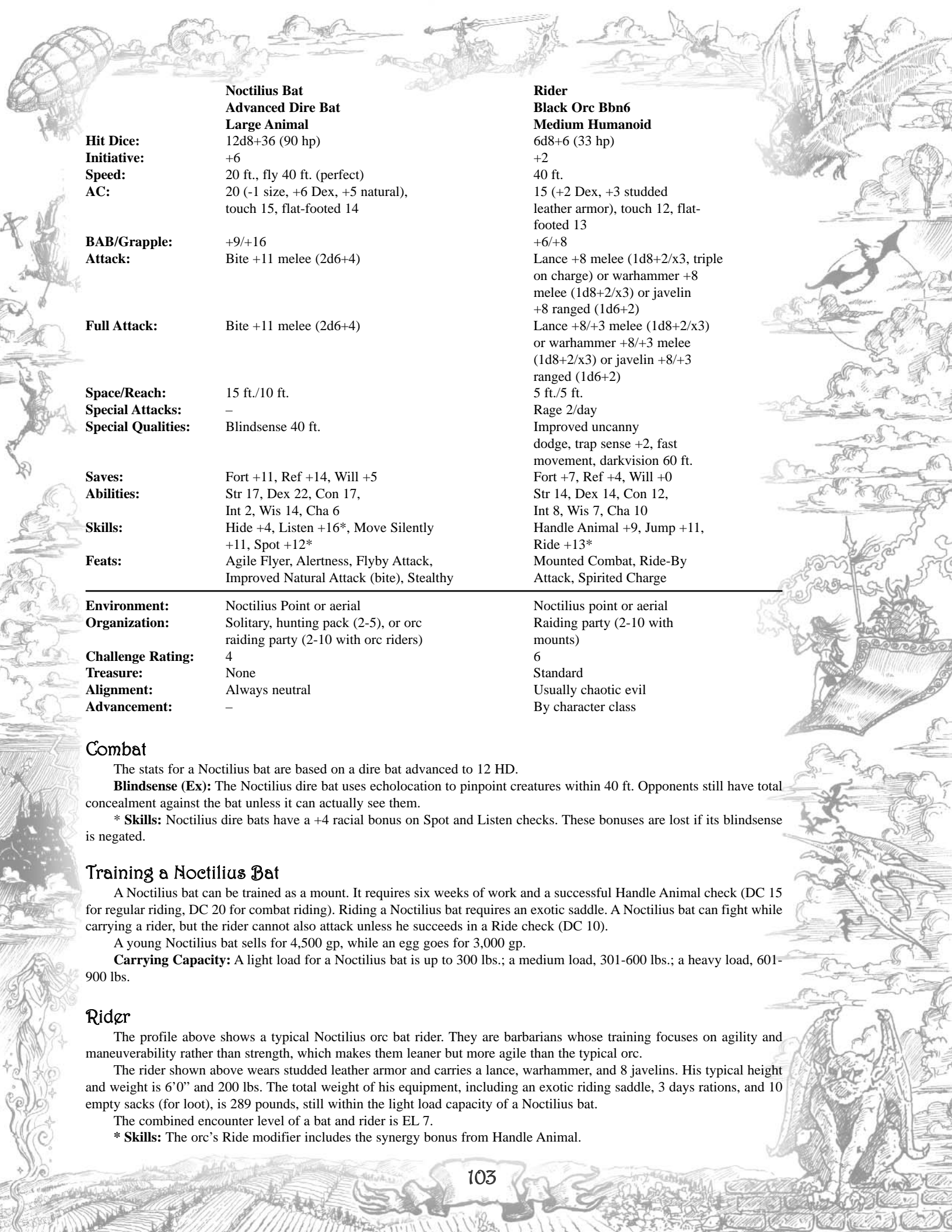

**Noctilius Bat**  
**Advanced Dire Bat**  
**Large Animal**

**Hit Dice:** 12d8+36 (90 hp)  
**Initiative:** +6  
**Speed:** 20 ft., fly 40 ft. (perfect)  
**AC:** 20 (-1 size, +6 Dex, +5 natural), touch 15, flat-footed 14

**BAB/Grapple:** +9/+16  
**Attack:** Bite +11 melee (2d6+4)

**Full Attack:** Bite +11 melee (2d6+4)

**Space/Reach:** 15 ft./10 ft.  
**Special Attacks:** –  
**Special Qualities:** Blindsight 40 ft.

**Saves:** Fort +11, Ref +14, Will +5  
**Abilities:** Str 17, Dex 22, Con 17, Int 2, Wis 14, Cha 6  
**Skills:** Hide +4, Listen +16\*, Move Silently +11, Spot +12\*  
**Feats:** Agile Flyer, Alertness, Flyby Attack, Improved Natural Attack (bite), Stealthy

**Rider**  
**Black Orc Bbn6**  
**Medium Humanoid**

6d8+6 (33 hp)  
+2  
40 ft.  
15 (+2 Dex, +3 studded leather armor), touch 12, flat-footed 13  
+6/+8  
Lance +8 melee (1d8+2/x3, triple on charge) or warhammer +8 melee (1d8+2/x3) or javelin +8 ranged (1d6+2)  
Lance +8/+3 melee (1d8+2/x3) or warhammer +8/+3 melee (1d8+2/x3) or javelin +8/+3 ranged (1d6+2)  
5 ft./5 ft.  
Rage 2/day  
Improved uncanny dodge, trap sense +2, fast movement, darkvision 60 ft.  
Fort +7, Ref +4, Will +0  
Str 14, Dex 14, Con 12, Int 8, Wis 7, Cha 10  
Handle Animal +9, Jump +11, Ride +13\*  
Mounted Combat, Ride-By Attack, Spirited Charge

**Environment:** Noctilius Point or aerial  
**Organization:** Solitary, hunting pack (2-5), or orc raiding party (2-10 with orc riders)  
**Challenge Rating:** 4  
**Treasure:** None  
**Alignment:** Always neutral  
**Advancement:** –

Noctilius point or aerial  
Raiding party (2-10 with mounts)  
6  
Standard  
Usually chaotic evil  
By character class

### Combat

The stats for a Noctilius bat are based on a dire bat advanced to 12 HD.

**Blindsight (Ex):** The Noctilius dire bat uses echolocation to pinpoint creatures within 40 ft. Opponents still have total concealment against the bat unless it can actually see them.

\* **Skills:** Noctilius dire bats have a +4 racial bonus on Spot and Listen checks. These bonuses are lost if its blindsense is negated.

### Training a Noctilius Bat

A Noctilius bat can be trained as a mount. It requires six weeks of work and a successful Handle Animal check (DC 15 for regular riding, DC 20 for combat riding). Riding a Noctilius bat requires an exotic saddle. A Noctilius bat can fight while carrying a rider, but the rider cannot also attack unless he succeeds in a Ride check (DC 10).

A young Noctilius bat sells for 4,500 gp, while an egg goes for 3,000 gp.

**Carrying Capacity:** A light load for a Noctilius bat is up to 300 lbs.; a medium load, 301-600 lbs.; a heavy load, 601-900 lbs.

### Rider

The profile above shows a typical Noctilius orc bat rider. They are barbarians whose training focuses on agility and maneuverability rather than strength, which makes them leaner but more agile than the typical orc.

The rider shown above wears studded leather armor and carries a lance, warhammer, and 8 javelins. His typical height and weight is 6'0" and 200 lbs. The total weight of his equipment, including an exotic riding saddle, 3 days rations, and 10 empty sacks (for loot), is 289 pounds, still within the light load capacity of a Noctilius bat.

The combined encounter level of a bat and rider is EL 7.

\* **Skills:** The orc's Ride modifier includes the synergy bonus from Handle Animal.



# OMBOSI

<b>Hit Dice:</b>	2d8+4 (13 hp)
<b>Initiative:</b>	+3
<b>Speed:</b>	30 ft., fly 30 ft. (poor)
<b>Armor Class:</b>	18 (+3 Dex, +3 natural, +2 heavy shield), touch 13, flat-footed 15
<b>BAB/Grapple:</b>	+1/+1
<b>Attack:</b>	Shortspear +0 melee (1d6-1) or throwing iron +4 ranged (1d4-1/19-20)
<b>Full Attack:</b>	Shortspear +0 melee (1d6-1) or throwing iron +4 ranged (1d4-1/19-20)
<b>Space/Reach:</b>	5 ft./5 ft.
<b>Special Attacks:</b>	Plummeting charge
<b>Special Qualities:</b>	Fast healing 3, resistance to falling damage
<b>Saves:</b>	Fort +5, Ref +3, Will +1
<b>Abilities:</b>	Str 8, Dex 17, Con 15, Int 12, Wis 12, Cha 8
<b>Skills:</b>	Hide +7, Listen +7, Spot +7, Survival +4
<b>Feats:</b>	Alertness, Flyby Attack
<b>Environment:</b>	Aerial, mountains
<b>Organization:</b>	Solitary, pair, band (3-15), tribe (16-50), or clan (51-100)
<b>Challenge Rating:</b>	2
<b>Treasure:</b>	Standard
<b>Alignment:</b>	Usually neutral evil
<b>Advancement:</b>	By character class



**Level Adjustment:** +1

Where these pugnacious creatures hail from is unknown, but there is much speculation that the khasri are responsible for importing them as thugs and harriers in their service. They are fearless little creatures with a sense of daring, and an inability to resist a challenge. Luckily for those that employ them, once they accept a contract they follow it, without the slightest hint of treachery. But when a contract ends, all bets are off, and the employer becomes fair game as far as the ombosi are concerned.

Ombosi are slight creatures standing roughly five feet tall and covered head-to-toe with multicolored, patterned scales. Their limbs are long and sinewy, ending with exceedingly long fingers and toes with flexible, tough webbing stretched between them. During freefall the ombosi can extend these webs to serve as drag, drastically slowing their fall, allowing them to avoid splattering to the ground like a thrown tomato. Their faces are slightly humanoid, with a mouthful of crooked fangs, and leering red eyes. Adding to their striking appearance is a large, ornate bone crest that emerges from their forehead and sweeps back. The ombosi place great stock in this crest, with each individual adorning his crest with all manner of ornamentation.

Proceeding down the center of the ombosi's back is a procession of protruding dull spines. On either side of this ridge of spines there is located a colorful, translucent sack that pulses rhythmically with the ombosi's breathing. These sacks can be quickly inflated by an organ that converts and stores digestive gases that, when combined with heavy inhalation, serve to create a pair of lighter-than-air bladders that the ombosi use to fly. At the back of each of these blad-

ders is a small rictus that allows air to escape, propelling the ombosi along at a slow speed. They can choose to move very swiftly by forcing air out in a tremendous burst, but they then must rely on their hands and feet to slow them down enough to re-inflate. Should an ombosi be unfortunate enough to fall, they possess a preternaturally tough skin, flexible, resilient bones, and a tremendous capacity to heal swiftly, so falls that would kill most normal beings outright are a mere trifle for the ombosi.

As a culture, they are clannish, yielding authority to the best warrior among them. They value cunning as well as individual might, so one does not always see the biggest and strongest running a band, but the best overall warrior or warrioress. This chieftain (usually a fighter of level 5-10) is called the Sholokun by his subordinates, and is advised by anywhere from one to five Oya (clerics of level 1-8). The Oya worship a patron deity called Ombombu, who grants access to the Air, Healing, Magic, and War domains. His favored weapon is the shortspear. All ombosi clans have a small collection of Usimbi (sorcerers level 1-8).

In ombosi society, males and females are physical and social equals, and in all truth, one may be hard put to tell them apart, as the differences are slight. Only the ombosi can tell which among them is male or female with any accuracy. They tend to forego clothing, finding their skins far more suitable and attractive than any cloth or armor, although they will don kilts and loincloths for their more prudish clients. It is also interesting to note that even in the chill of high altitudes they seem not to be the least bit bothered by going about naked.

**Hit Dice:** 10d8+30 (75 hp)  
**Initiative:** +4  
**Speed:** 30 ft., fly 30 ft. (poor)  
**Armor Class:** 21 (+4 Dex, +3 natural, +4 +2 *heavy wooden shield*), touch 14, flat-footed 17

**BAB/Grapple:** +9/+9  
**Attack/Full Attack:** +1 *longspear* +12/+7 melee (1d8+3/x3) or throwing iron +13/+8 ranged (1d4/19-20)

**Space/Reach:** 5 ft./5 ft.  
**Special Attacks:** Plummeting charge  
**Special Qualities:** Fast healing 3, resistance to falling damage

**Saves:** Fort +12, Ref +6, Will +3  
**Abilities:** Str 11, Dex 18, Con 17, Int 12, Wis 12, Cha 8  
**Skills:** Handle Animal +11, Hide +13, Intimidate +10, Listen +10, Spot +10, Survival +4

**Feats:** Alertness, Cleave, Flyby Attack, Flyby Cleave, Great Cleave, Greater Weapon Focus (*longspear*), Power Attack, Thunderbolt Charge, Weapon Focus (*longspear*), Weapon Specialization (*longspear*)

**Environment:** Aerial, mountains  
**Organization:** 1 per clan  
**Challenge Rating:** 10  
**Treasure:** Standard (including +1 *longspear* and +2 *heavy wooden shield*)  
**Alignment:** Usually neutral evil  
**Advancement:** By character class

**Oya**  
**Ombosi Clr6**  
2d8+6d6+16 (46 hp)  
+3  
30 ft., fly 30 ft. (poor)  
18 (+3 Dex, +3 natural, +2 *heavy wooden shield*), touch 13, flat-footed 15  
+5/+5  
Shortspear +6 melee (1d6) or throwing iron +8 ranged (1d4/19-20)  
5 ft./5 ft.  
Plummeting charge, spells  
Fast healing 3, resistance to falling damage, turn undead, turn earth creatures  
Fort +10, Ref +7, Will +10  
Str 10, Dex 17, Con 15, Int 12, Wis 16, Cha 8  
Concentration +11, Heal +11, Hide +7, Listen +9, Spellcraft +10, Spot +9, Survival +9

**Alertness, Flyby Attack, Iron Will, Lightning Reflexes, Thunderbolt Charge, Weapon Focus (shortspear)**

**Environment:** Aerial, mountains  
**Organization:** 1-5 per clan  
**Challenge Rating:** 8  
**Treasure:** Standard  
**Alignment:** Usually neutral evil  
**Advancement:** By character class

**Usimbi**  
**Ombosi Sor4**  
2d8+4d4+12 (31 hp)  
+4  
30 ft., fly 30 ft. (poor)  
17 (+4 Dex, +3 natural), touch 14, flat-footed 13  
+3/+3  
Shortspear +2 melee (1d6-1) or throwing iron +7 ranged (1d4-1/19-20)  
5 ft./5 ft.  
Plummeting charge, spells  
Fast healing 3, resistance to falling damage, familiar  
Fort +6, Ref +5, Will +7  
Str 8, Dex 18, Con 15, Int 11, Wis 12, Cha 14  
Concentration +7, Hide +7, Listen +7, Spot +7 (+10 in bright light), Spellcraft +7, Survival +4  
**Alertness, Flyby Attack, Iron Will, Spell Penetration**

**Environment:** Aerial, mountains  
**Organization:** 1-2 per clan  
**Challenge Rating:** 6  
**Treasure:** Standard  
**Alignment:** Usually neutral evil  
**Advancement:** By character class

## Combat

In combat, the ombosi prefer to ambush their enemies, either by deflating their air sacks and hurtling recklessly into the fray, or plunging in a freefall from above. They have mastered the art of charging and attacking as they fly by. They all prefer to use spears and other pole arms adjusted for their size and their over-long fingers, although some also use ornate throwing irons and crossbows. Occasionally they will carry with them ovoid shields made of wood and hide painted in garish clashing colors. Ombosi use numbers and clever planning to overbear and outwit their opponents, but while they prefer the odds in their favor they are not to be underestimated as individual combatants.

**Fast Healing (Ex):** Ombosi heal damage at an astonishing rate, regaining 3 hit points per round. They cannot heal fire damage in this manner, or re-grow lost limbs.

**Resistance to Falling Damage (Ex):** An ombosi can fall up to 50 feet and take no damage. For every 10 feet fall beyond 50 they take only 1d4 points of nonlethal damage, up to a maximum of 20d4. This is assuming, of course, that they are not using their digital membranes to slow their fall.

**Plummeting Charge:** The ombosi love to drop in on their enemies from high above. They will deflate their air bladders and fall onto their enemies with weapons ready. Unless the target is eligible for a Spot check against creatures falling from above, this sort of attack almost always results in a surprise round for the ombosi. This attack counts as a charge for the ombosi.

## Ombosi Oya

The Oya shown here is a 6th level cleric with access to the Air and War domains.

**Cleric Spells** (5/4+1/4+1/3+1, save DC = 13 + spell level): 0th—*create water, cure minor wounds, guidance, resistance, virtue*; 1st—*bane, cure light wounds, entropic shield, inflict light wounds, magic weapon\**; 2nd—*bull's strength, cure moderate wounds, hold person (x2), wind wall\**; 3rd—*bestow curse, cure serious wounds, inflict serious wounds, magic vestment\**. \*Domain spell.

## Ombosi Usimbi

The Usimbi shown here is a 4th level sorcerer with a

hawk familiar.

*Sorcerer Spells* (6/7/4, save DC = 12 + spell level): 0th—*daze, message, ray of frost, resistance*; 1st—*color spray, feather fall, hypnotism, mage armor, magic missile, ray of enfeeblement*; 2nd—*cat's grace, invisibility, scorching ray, web*.

**Hawk Familiar:** CR —; Tiny animal; HD 6 (effective); hp 15; Init +3; Spd. 10 ft., fly 60 ft. (average); AC 19, touch 15, flat-footed 16; Base Atk +3; Grp -7; Atk talons +6 melee (1d4-2); Space/Reach 2-1/2 ft./0 ft.; SQ alertness, improved evasion, share spells, empathic link; AL usually LG; SV Fort +6, Ref +5, Will +7; Str 6, Dex 17, Con 10, Int 7, Wis 14, Cha 6.

*Skills and feats:* As master plus Listen +7, Spot +15; Weapon Finesse.

## Ombosi Characters

Ombosi are hardworking mercenaries always looking to take jobs, even the most menial. They are not above taking jobs as scouts, guides and porters just to alleviate boredom.

Ombosi characters possess the following racial traits.

- Strength -2, Constitution +4, Dexterity +6, Charisma -2
- Medium size.
- Fast healing 3, as described above
- Base speed 30 ft. on both land and in the air, with poor maneuverability
- Resistance to falling damage and plummeting charge abilities, as described above.
- Natural armor bonus of +3 to AC
- Racial Hit Dice: Ombosi begin with two levels of humanoid, giving them 2d8 hit dice, a base attack of +1, and saving throw bonuses of Fort +3, Ref +0, and Will +0.
- Racial Skills: The ombosi's humanoid levels give it skill points equal to 5 x (2 + Int modifier).
- Racial Feats: All ombosi start with the Flyby Attack feat for free.
- Favored Class: Fighter

## PLAGUE VULTURE

<b>Hit Dice:</b>	<b>Plague Vulture</b> Large Undead 6d12 (39 hp)	<b>Plague Winglord</b> Huge Undead 18d12 (117 hp)
<b>Initiative:</b>	+4	+4
<b>Speed:</b>	20 ft., fly 60 ft. (average)	20 ft., fly 60 ft. (good)
<b>AC:</b>	17 (+4 Dex, +4 natural, -1 size), touch 13, flat-footed 13	20 (+4 Dex, +8 natural, -2 size), touch 12, flat-footed 16
<b>BAB/Grapple:</b>	+3/+9	+9/+23
<b>Attack:</b>	Bite +4 melee (1d8+2)	Bite +13 melee (2d6+6)
<b>Full Attack:</b>	Bite +4 melee (1d8+2) and 2 claws +2 melee (1d6+2)	Bite +13 melee (2d6+6) and 2 claws +11 melee (1d8+6)
<b>Space/Reach:</b>	5 ft./5 ft.	15 ft./15 ft.
<b>Special Attacks:</b>	Improved grab	Improved grab
<b>Special Qualities:</b>	Carrion stench	Carrion stench
<b>Saves:</b>	Fort +2, Ref +2, Will +5	Fort +6, Ref +10, Will +12
<b>Abilities:</b>	Str 14, Dex 18, Con —, Int 10, Wis 12, Cha 10	Str 22, Dex 18, Con —, Int 10, Wis 12, Cha 10
<b>Skills:</b>	Listen +11, Move Silently +14, Spot +11, Survival +11	Listen +22, Move Silently +25, Spot +22, Survival +22
<b>Feats:</b>	Flyby Attack, Multiattack	Agile Flier, Flyby Attack, Improved Natural Armor, Multiattack, Snatch, Thunderbolt Charge
<b>Environment:</b>	Any land or air	Any land or air
<b>Organization:</b>	Solitary, flock (2-12), or flight (13-24)	Solitary, flock (2-6), or flight (7-12)
<b>Challenge Rating:</b>	2	5
<b>Treasure:</b>	Standard	Standard
<b>Alignment:</b>	Always neutral evil	Always neutral evil
<b>Advancement:</b>	7-12 HD (Large), 13-18 HD (Huge)	—

Plague vultures are large, skeletal birds of prey that delight in grabbing travelers and dropping them to their deaths. While these creatures are poor fighters on their own, their durability and often large numbers make them difficult opponents for merchants, neophyte adventurers, and other travelers.

The plague vulture is a great skeletal bird with bat-like wings. Its internal organs remain tucked within its rib cage. Though long dead, these body parts emit a horrifying stench that chokes living creatures and disrupts their efforts. This mon-

ster receives its name from its long, hooked beak that resembles a vulture's. The plague winglord is a much greater version made from the remains of dragons, wyverns, or other large flyers.

Normally created by necromancers, evil clerics, and other servants of dark gods, the plague vulture serves as a scout and terror troop. Though outclassed by heavily armed and armored warriors, these monsters feast on poorly trained or unarmed innocents. They prefer to grab their prey and drop them over civilized areas, both to kill their victims and spread terror as their prey drops to a messy death in a town square or other crowded place.

## Combat

In battle, plague vultures prefer to swoop upon their enemies and then use their speed to escape after making an attack. These beasts loathe toe-to-toe fights, particularly against warriors in heavy armor or equipped with potent weapons. Only when compelled by a cleric or necromancer do these undead beasts throw themselves into the fray.

**Undead:** Immune to poison, sleep effects, paralysis, stunning, disease, death effects, necromantic effects, mind-influencing effects, critical hits, nonlethal damage, ability damage, ability drain, or energy drain. As undead lack Constitution scores, they are immune to anything that requires a Fortitude save.

**Improved Grab (Ex):** If the plague vulture hits with a claw attack, it may attempt to initiate a grapple against its target in addition to dealing damage as normal. The plague vulture does not draw attacks of opportunity when using this ability. Once a vulture has a target held in a grapple, it may attempt to fly off with its victim. The vulture must be strong enough to drag its victim's weight and must also succeed at an opposed Strength check against its victim to pull him into the air.

**Carrion Stench (Su):** The stench of death and decay surrounds the plague vulture, generated by the rotting, foul organs that still linger on within its rib cage. The stench is incredibly strong, enough to distract those who come within 60 feet of the beast. All characters must make a Fortitude save or suffer a -1 penalty to attacks and checks. Spellcasters must make a Concentration check when attempting to cast a spell within this area or be overwhelmed by the stench while attempting to complete their magic. A spell disrupted in this way is not ruined, and the caster may attempt to use the spell again on his next action. The DC for Fortitude saves and Concentration checks is 13 for a plague vulture and 16 for a plague winglord.

## RAIN SPRITE

Rain sprites are small, winged fairies that follow thunderclouds and other rainstorms as they travel across the sky. The sprites are mischievous and delight in seeing others get a good soaking. They have abilities that allow them to control the weather and have been known to force a drought or floods upon areas that have antagonized them in the past.

The typical rain sprite is three feet tall and has a pair of large butterfly wings on his back. These creatures look like a cross between elves and halflings, with their pointed ears, almond shaped eyes, and delicate features combined with their short, almost childlike stature. The air around a rain

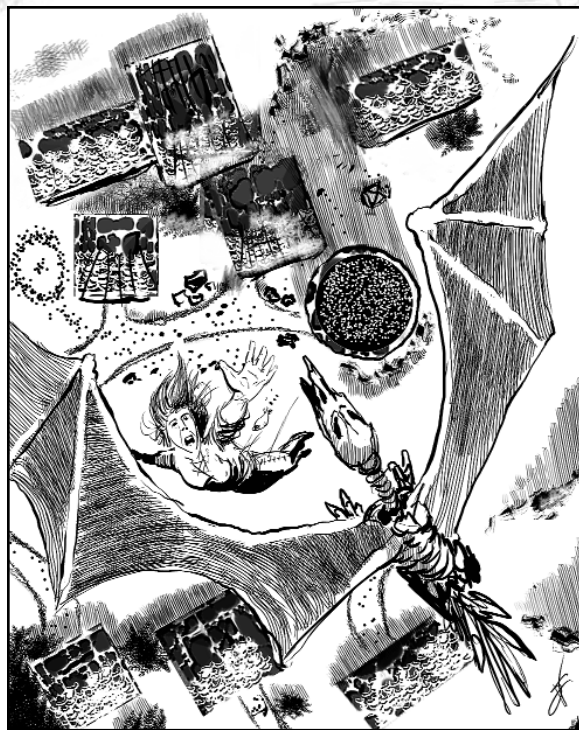

sprite feels cooler and damper than normal and their light blue skin is often covered with a slight layer of glistening moisture. Rain sprites wear loose-fitting togas and belts on which they hang their elaborately wrought blades and crossbows.

Rain sprites are known for their often cruel, random natures. They have little understanding of the role rain plays on the surface world or how a terrible storm that feels fun and exciting to them can prove to be the death of mariners both in the air and on the sea. Like children granted too much power, they can be petulant, demanding, and utterly unreasonable. Luckily for most humanoid races, these creatures prefer to enjoy natural storms and usually are too busy with their own affairs to trouble mortals.

## Combat

Most rain sprites carry a short blade and a crossbow for hunting and protection, though most prefer to rely on their spell abilities to deal with foes. While their weather and climate control abilities have little bearing on most battles, they typically use them to avenge themselves against a surface settlement or region that has wronged them. However, all too often these insults and slights are imagined or vastly exaggerated.

**Spells:** A rain sprite may use the following spells three times per day as a 15th-level sorcerer: *ray of frost*, *control weather*, *gust of wind*.

**Water Mastery (Su):** As a standard action, a rain sprite may call into existence a tiny rain cloud that pours water on to a 30 foot radius area. The rain is brief but torrential. Any creature within the area must make a Balance (DC 20) check to avoid being knocked to the ground by the heavy rains. In addition, the ground turns into a thick, muddy mire. All creatures within the area move at half their normal rate. The rain sprite may use this ability three times per day.



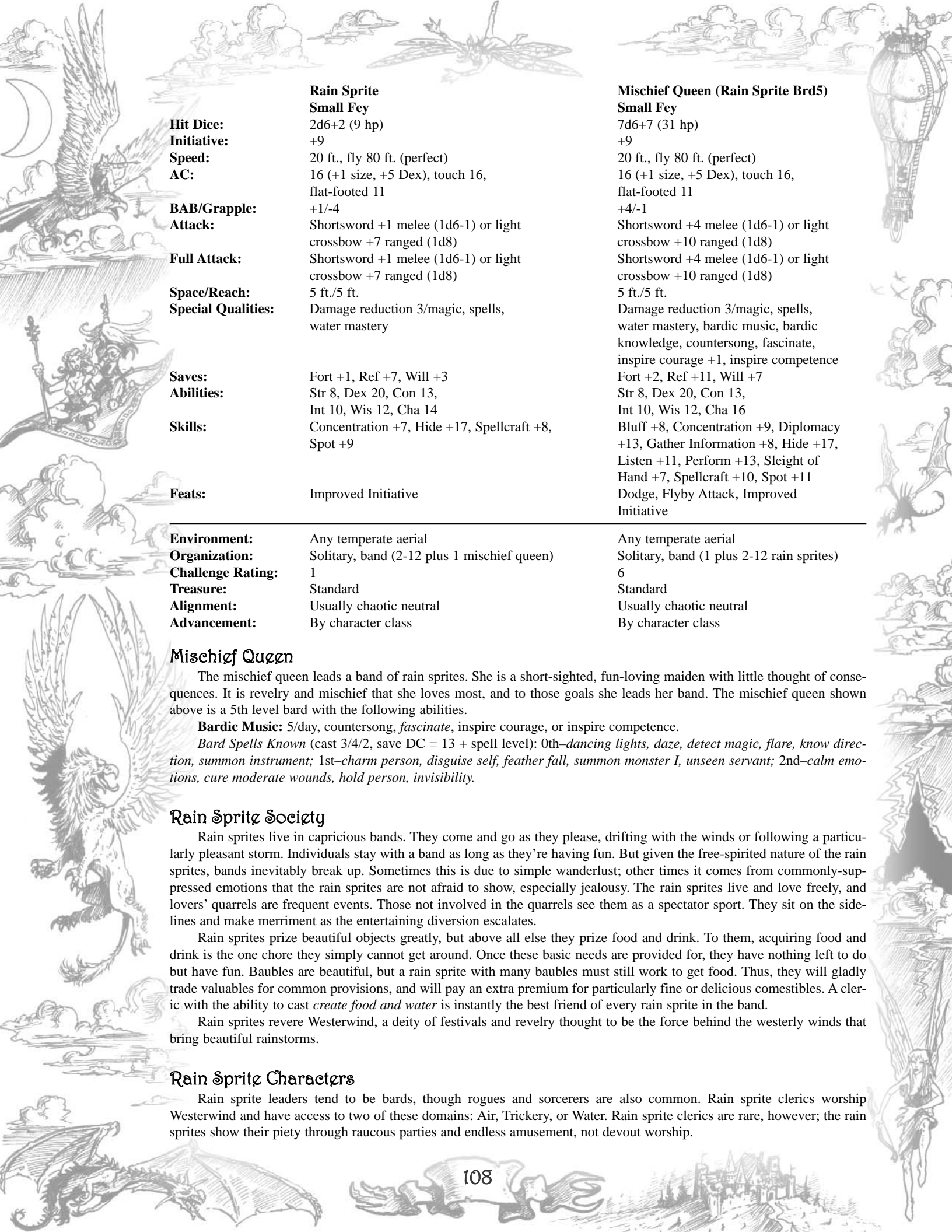

**Rain Sprite**  
**Small Fey**  
**Hit Dice:** 2d6+2 (9 hp)  
**Initiative:** +9  
**Speed:** 20 ft., fly 80 ft. (perfect)  
**AC:** 16 (+1 size, +5 Dex), touch 16, flat-footed 11  
**BAB/Grapple:** +1/-4  
**Attack:** Shortsword +1 melee (1d6-1) or light crossbow +7 ranged (1d8)  
**Full Attack:** Shortsword +1 melee (1d6-1) or light crossbow +7 ranged (1d8)  
**Space/Reach:** 5 ft./5 ft.  
**Special Qualities:** Damage reduction 3/magic, spells, water mastery  
**Saves:** Fort +1, Ref +7, Will +3  
**Abilities:** Str 8, Dex 20, Con 13, Int 10, Wis 12, Cha 14  
**Skills:** Concentration +7, Hide +17, Spellcraft +8, Spot +9  
**Feats:** Improved Initiative

**Mischief Queen (Rain Sprite Brd5)**  
**Small Fey**  
**Hit Dice:** 7d6+7 (31 hp)  
**Initiative:** +9  
**Speed:** 20 ft., fly 80 ft. (perfect)  
**AC:** 16 (+1 size, +5 Dex), touch 16, flat-footed 11  
**BAB/Grapple:** +4/-1  
**Attack:** Shortsword +4 melee (1d6-1) or light crossbow +10 ranged (1d8)  
**Full Attack:** Shortsword +4 melee (1d6-1) or light crossbow +10 ranged (1d8)  
**Space/Reach:** 5 ft./5 ft.  
**Special Qualities:** Damage reduction 3/magic, spells, water mastery, bardic music, bardic knowledge, countersong, fascinate, inspire courage +1, inspire competence  
**Saves:** Fort +2, Ref +11, Will +7  
**Abilities:** Str 8, Dex 20, Con 13, Int 10, Wis 12, Cha 16  
**Skills:** Bluff +8, Concentration +9, Diplomacy +13, Gather Information +8, Hide +17, Listen +11, Perform +13, Sleight of Hand +7, Spellcraft +10, Spot +11  
**Feats:** Dodge, Flyby Attack, Improved Initiative

**Environment:** Any temperate aerial  
**Organization:** Solitary, band (2-12 plus 1 mischief queen)  
**Challenge Rating:** 1  
**Treasure:** Standard  
**Alignment:** Usually chaotic neutral  
**Advancement:** By character class

**Environment:** Any temperate aerial  
**Organization:** Solitary, band (1 plus 2-12 rain sprites)  
**Challenge Rating:** 6  
**Treasure:** Standard  
**Alignment:** Usually chaotic neutral  
**Advancement:** By character class

### Mischief Queen

The mischief queen leads a band of rain sprites. She is a short-sighted, fun-loving maiden with little thought of consequences. It is revelry and mischief that she loves most, and to those goals she leads her band. The mischief queen shown above is a 5th level bard with the following abilities.

**Bardic Music:** 5/day, countersong, *fascinate*, inspire courage, or inspire competence.

**Bard Spells Known** (cast 3/4/2, save DC = 13 + spell level): 0th—*dancing lights, daze, detect magic, flare, know direction, summon instrument*; 1st—*charm person, disguise self, feather fall, summon monster I, unseen servant*; 2nd—*calm emotions, cure moderate wounds, hold person, invisibility*.

### Rain Sprite Society

Rain sprites live in capricious bands. They come and go as they please, drifting with the winds or following a particularly pleasant storm. Individuals stay with a band as long as they're having fun. But given the free-spirited nature of the rain sprites, bands inevitably break up. Sometimes this is due to simple wanderlust; other times it comes from commonly-suppressed emotions that the rain sprites are not afraid to show, especially jealousy. The rain sprites live and love freely, and lovers' quarrels are frequent events. Those not involved in the quarrels see them as a spectator sport. They sit on the sidelines and make merriment as the entertaining diversion escalates.

Rain sprites prize beautiful objects greatly, but above all else they prize food and drink. To them, acquiring food and drink is the one chore they simply cannot get around. Once these basic needs are provided for, they have nothing left to do but have fun. Baubles are beautiful, but a rain sprite with many baubles must still work to get food. Thus, they will gladly trade valuables for common provisions, and will pay an extra premium for particularly fine or delicious comestibles. A cleric with the ability to cast *create food and water* is instantly the best friend of every rain sprite in the band.

Rain sprites revere Westerwind, a deity of festivals and revelry thought to be the force behind the westerly winds that bring beautiful rainstorms.

### Rain Sprite Characters

Rain sprite leaders tend to be bards, though rogues and sorcerers are also common. Rain sprite clerics worship Westerwind and have access to two of these domains: Air, Trickery, or Water. Rain sprite clerics are rare, however; the rain sprites show their piety through raucous parties and endless amusement, not devout worship.

Rain sprite characters have these racial traits:

- -2 Strength, +10 Dexterity, +2 Constitution, +2 Wisdom, +4 Charisma.
- Small size.
- A rain sprite's base land speed is 20 ft. They can fly at a speed of 80 ft. with perfect maneuverability.
- Damage reduction 3/magic.
- Special Attacks (see above): Water mastery; ability to cast *ray of frost*, *control weather*, and *gust of wind* 3/day as a 15th level sorcerer.
- Racial Hit Dice: A rain sprite begins with two levels of fey, which provide 2d6 hit dice, a base attack bonus of +1, and base saving throw bonuses of Fort +0, Ref +2, and Will +2.
- Racial Skills: A rain sprite's racial levels give it skill points equal to 5 x (6 + Int modifier, minimum 1). Its class skills are Concentration, Hide, Spellcraft, and Spot.
- Racial Feat: The sprite's racial levels give it one feat.
- Automatic Languages: Common. Bonus Languages: Elven, Auran, Draconic.
- Favored Class: Bard.
- Level adjustment: +3.



## SKAERDRIM

### Skaerdrim Worker Medium Outsider (Air, Chaotic)

<b>Hit Dice:</b>	2d8+4 (13 hp)
<b>Initiative:</b>	+1
<b>Speed:</b>	20 ft., fly 30 ft. (average)
<b>AC:</b>	19 (+1 Dex, +2 studded leather, +4 natural, +2 large steel shield), touch 11, flat-footed 18
<b>BAB/Grapple:</b>	+2/+4
<b>Attack:</b>	Heavy pick +5 melee (1d6+2 +1 cold) or light crossbow +3 ranged (1d8)
<b>Full Attack:</b>	Heavy pick +5 melee (1d6+2 +1 cold) or light crossbow +3 ranged (1d8)
<b>Space/Reach:</b>	5 ft./5 ft.
<b>Special Attacks:</b>	Cold
<b>Special Qualities:</b>	SR 13, cold subtype
<b>Saves:</b>	Fort +5, Ref +4, Will +3
<b>Abilities:</b>	Str 14, Dex 12, Con 14, Int 10, Wis 10, Cha 9
<b>Skills:</b>	Appraise +5, Balance +6, Craft (metalworking) +5, Knowledge (geography) +5, Profession (miner) +5, Search +5, Spot +5, Survival +5
<b>Feats:</b>	Weapon Focus (heavy pick)

### Foreman (Skaerdrim Exp3) Medium Outsider (Air, Chaotic)

<b>Hit Dice:</b>	2d8+3d6+10 (29 hp)
<b>Initiative:</b>	+1
<b>Speed:</b>	20 ft., fly 30 ft. (average)
<b>AC:</b>	19 (+1 Dex, +2 studded leather, +4 natural, +2 large steel shield), touch 11, flat-footed 18
<b>BAB/Grapple:</b>	+4/+7
<b>Attack:</b>	Heavy pick +8 melee (1d6+3 +1 cold) or light crossbow +5 ranged (1d8)
<b>Full Attack:</b>	Heavy pick +8 melee (1d6+3 +1 cold) or light crossbow +5 ranged (1d8)
<b>Space/Reach:</b>	5 ft./5 ft.
<b>Special Attacks:</b>	Cold
<b>Special Qualities:</b>	SR 13, cold subtype
<b>Saves:</b>	Fort +6, Ref +5, Will +6
<b>Abilities:</b>	Str 16, Dex 12, Con 14, Int 10, Wis 10, Cha 11
<b>Skills:</b>	Appraise +8, Balance +9, Craft (metalworking) +8, Knowledge (geography) +8, Knowledge (the planes) +8, Listen +2, Profession (miner) +10, Spot +8, Search +8, Survival +8
<b>Feats:</b>	Endurance, Skill Focus (Profession [miner]), Weapon Focus (heavy pick)

<b>Environment:</b>	Arctic or any aerial
<b>Organization:</b>	Solitary, pair, prospecting team (2-12 plus 1 3rd-level foreman)
<b>Challenge Rating:</b>	2
<b>Treasure:</b>	Standard coins; double gems
<b>Alignment:</b>	Chaotic neutral
<b>Advancement:</b>	By character class

<b>Environment:</b>	Arctic or any aerial
<b>Organization:</b>	Solitary or prospecting team (1 plus 2-12 workers)
<b>Challenge Rating:</b>	4
<b>Treasure:</b>	Standard coins; double gems
<b>Alignment:</b>	Chaotic neutral
<b>Advancement:</b>	By character class



Skaerdrim are blue-skinned creatures with thick white hair and beards. Their skin is coated in a slight tinge of frost, and often small icicles form on their noses and in their beards. These creatures are dwarves native to the plane of air. They inhabit a frigid zone of that realm that borders close to the plane of water. Dwelling within great vaults carved from chunks of ice that coast along the plane of air's currents, the skaerdrim delve deep into the ice and rock for gems, minerals, and other valuables. Sometimes, skaerdrim prospectors journey to the prime material plane in search of rich veins of ore. Unlike normal dwarves, the skaerdrim prefer to mine clouds and aerial realms, drawing their magical essence and using arcane processes similar to those they use in pure ice veins to manufacture sparkling gems and mithral ingots.

Skaerdrim normally use sky ships for travel. Although they can fly, they lack the size and speed to carry all the supplies, weapons, and armor they need while prospecting or riding into war. In battle, they approach their enemies aboard their ships and only use their flying ability when they close into melee range.

## Combat

Unlike their mundane cousins, the skaerdrim are wild, chaotic warriors who rely on mass charges and sheer ferocity to carry the day. They prefer to launch a volley of crossbow bolts before wading into melee with their picks. While skaerdrim rarely engage in wanton raiding, they are fiercely territorial and extremely greedy. They eagerly attack anyone who threatens their mining territory, sometimes going so far as to interpret simple trespass in the region as an intolerable threat.

Skaerdrim and azer are mortal enemies. The two races invariably fight over mining territory when their paths cross. Fortunately, these two races venture into distinctly different areas of the prime material plane.

**Cold (Ex):** Skaerdrim are always surrounded by a field of intensely cold air generated by their bodies. When they

attack in melee with their bare hands or weapons, they deal an additional point of cold damage on a hit.

**Cold Subtype (Ex):** Skaerdrim are immune to all cold damage and take double damage from fire attacks on a failed save.

## Skaerdrim Society

Skaerdrim are dour, sullen creatures. Only one thing lights their eyes: gold. They spend their lives in a constant state of hard labor, rewarded by the gems and metals that labor produces. Their social unit is the itinerant prospecting team, and members of each team are invariably related. Because skaerdrim reproduce rarely and mature very slowly, a prospecting team generally replaces elders with new youth at about the same rate the elders die off. Skaerdrim "youth" are anything but youthful; they are just as sullen as their parents.

The prospecting teams move around constantly, always in search of new mines. They are united primarily by trade ties. Ambitious skaerdrim form longstanding trade relationships by marrying their sons and daughters into other prospecting teams. It is through such webs of contact that skaerdrim are able to specialize in certain ores or gems. One team might prospect solely for anthracite, which it then trades into its network to receive gold, food, or ale from distant relations in far-off prospecting teams.

Skaerdrim are not particularly violent, but they value their possessions. They are extremely materialistic and will gladly die defending a prized mine.

Skaerdrim do not take the time to worship a god. They see it as an unnecessary distraction from work. Nonetheless, they do have clerics, who draw a mystical power from the pure elemental energy of the plane of air. This is channeled by their close connections to one or two elder air elementals, who act as patrons and advisors to skaerdrim bands in exchange for material donations and combat or labor assistance when needed. Most contact with the elemental patrons goes through the clerics, who somehow draw divine power from such direct interaction with pure elemental forces.

## Skaerdrim Characters

Skaerdrim leaders are called foremen. They tend to be experts who specialize in mining. Prospecting teams that frequent contested areas, or which specialize in acquiring their ore from the mines of other creatures, often have leaders with warrior levels as well. Skaerdrim clerics worship no god but must spend one full hour a day communing with their patron elemental. As long as they maintain this contact, they receive divine spells and have access to the domains of Air and Travel.

Skaerdrim characters possess the following racial traits:

- +2 Strength, +2 Dexterity, +4 Constitution, -2 Charisma.
- Medium size.
- A skaerdrim's base land speed is 20 ft. They can fly at a speed of 30 ft. with average maneuverability.
- Spell resistance 13.
- Special Qualities (see above): Cold damage, cold subtype.
- Racial Hit Dice: A skaerdrim begins with two levels of outsider, which provide 2d8 hit dice, a base attack

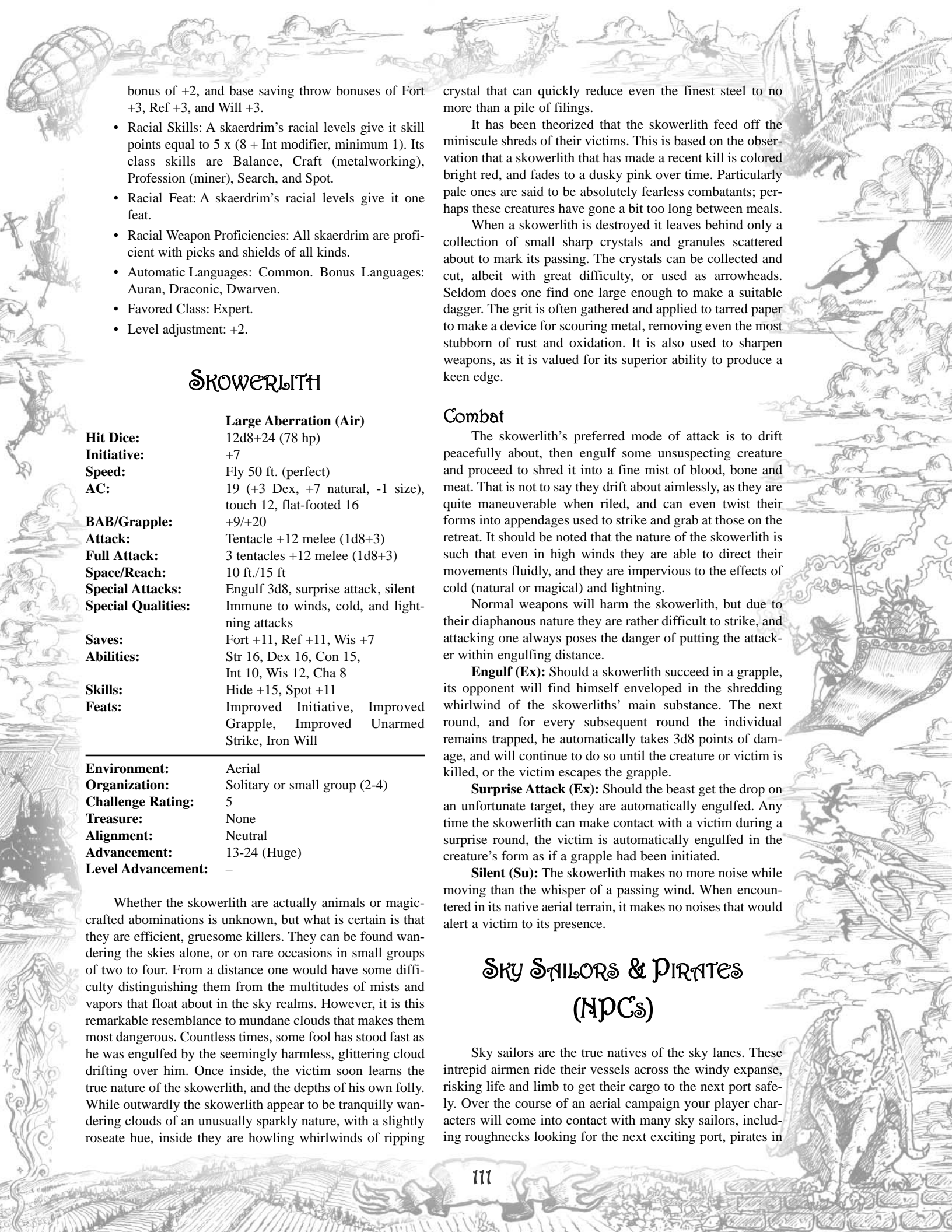

bonus of +2, and base saving throw bonuses of Fort +3, Ref +3, and Will +3.

- **Racial Skills:** A skaerdrim's racial levels give it skill points equal to 5 x (8 + Int modifier, minimum 1). Its class skills are Balance, Craft (metalworking), Profession (miner), Search, and Spot.
- **Racial Feat:** A skaerdrim's racial levels give it one feat.
- **Racial Weapon Proficiencies:** All skaerdrim are proficient with picks and shields of all kinds.
- **Automatic Languages:** Common. **Bonus Languages:** Auran, Draconic, Dwarven.
- **Favored Class:** Expert.
- **Level adjustment:** +2.

## SKOWERLITH

<b>Hit Dice:</b>	12d8+24 (78 hp)
<b>Initiative:</b>	+7
<b>Speed:</b>	Fly 50 ft. (perfect)
<b>AC:</b>	19 (+3 Dex, +7 natural, -1 size), touch 12, flat-footed 16
<b>BAB/Grapple:</b>	+9/+20
<b>Attack:</b>	Tentacle +12 melee (1d8+3)
<b>Full Attack:</b>	3 tentacles +12 melee (1d8+3)
<b>Space/Reach:</b>	10 ft./15 ft
<b>Special Attacks:</b>	Engulf 3d8, surprise attack, silent
<b>Special Qualities:</b>	Immune to winds, cold, and lightning attacks
<b>Saves:</b>	Fort +11, Ref +11, Wis +7
<b>Abilities:</b>	Str 16, Dex 16, Con 15, Int 10, Wis 12, Cha 8
<b>Skills:</b>	Hide +15, Spot +11
<b>Feats:</b>	Improved Initiative, Improved Grapple, Improved Unarmed Strike, Iron Will
<hr/>	
<b>Environment:</b>	Aerial
<b>Organization:</b>	Solitary or small group (2-4)
<b>Challenge Rating:</b>	5
<b>Treasure:</b>	None
<b>Alignment:</b>	Neutral
<b>Advancement:</b>	13-24 (Huge)
<b>Level Advancement:</b>	—

Whether the skowerlith are actually animals or magic-crafted abominations is unknown, but what is certain is that they are efficient, gruesome killers. They can be found wandering the skies alone, or on rare occasions in small groups of two to four. From a distance one would have some difficulty distinguishing them from the multitudes of mists and vapors that float about in the sky realms. However, it is this remarkable resemblance to mundane clouds that makes them most dangerous. Countless times, some fool has stood fast as he was engulfed by the seemingly harmless, glittering cloud drifting over him. Once inside, the victim soon learns the true nature of the skowerlith, and the depths of his own folly. While outwardly the skowerlith appear to be tranquilly wandering clouds of an unusually sparkly nature, with a slightly roseate hue, inside they are howling whirlwinds of ripping

crystal that can quickly reduce even the finest steel to no more than a pile of filings.

It has been theorized that the skowerlith feed off the miniscule shreds of their victims. This is based on the observation that a skowerlith that has made a recent kill is colored bright red, and fades to a dusky pink over time. Particularly pale ones are said to be absolutely fearless combatants; perhaps these creatures have gone a bit too long between meals.

When a skowerlith is destroyed it leaves behind only a collection of small sharp crystals and granules scattered about to mark its passing. The crystals can be collected and cut, albeit with great difficulty, or used as arrowheads. Seldom does one find one large enough to make a suitable dagger. The grit is often gathered and applied to tarred paper to make a device for scouring metal, removing even the most stubborn of rust and oxidation. It is also used to sharpen weapons, as it is valued for its superior ability to produce a keen edge.

## Combat

The skowerlith's preferred mode of attack is to drift peacefully about, then engulf some unsuspecting creature and proceed to shred it into a fine mist of blood, bone and meat. That is not to say they drift about aimlessly, as they are quite maneuverable when riled, and can even twist their forms into appendages used to strike and grab at those on the retreat. It should be noted that the nature of the skowerlith is such that even in high winds they are able to direct their movements fluidly, and they are impervious to the effects of cold (natural or magical) and lightning.

Normal weapons will harm the skowerlith, but due to their diaphanous nature they are rather difficult to strike, and attacking one always poses the danger of putting the attacker within engulfing distance.

**Engulf (Ex):** Should a skowerlith succeed in a grapple, its opponent will find himself enveloped in the shredding whirlwind of the skowerlith's main substance. The next round, and for every subsequent round the individual remains trapped, he automatically takes 3d8 points of damage, and will continue to do so until the creature or victim is killed, or the victim escapes the grapple.

**Surprise Attack (Ex):** Should the beast get the drop on an unfortunate target, they are automatically engulfed. Any time the skowerlith can make contact with a victim during a surprise round, the victim is automatically engulfed in the creature's form as if a grapple had been initiated.

**Silent (Su):** The skowerlith makes no more noise while moving than the whisper of a passing wind. When encountered in its native aerial terrain, it makes no noises that would alert a victim to its presence.

## SKY SAILORS & PIRATES (NPCs)

Sky sailors are the true natives of the sky lanes. These intrepid airmen ride their vessels across the windy expanse, risking life and limb to get their cargo to the next port safely. Over the course of an aerial campaign your player characters will come into contact with many sky sailors, including roughnecks looking for the next exciting port, pirates in





search of prey, and experienced captains looking for a few good hands.

The following stat blocks present playable game data for some of the more common varieties of sky sailor NPCs. Stats for merchant traders can be found on page 116.

A sky sailor is an expert who specializes in these class skills: Balance (Dex), Climb (Str), Craft (any one) (Int), Gather Information (Cha), Jump (Str), Knowledge (local) (Int), Profession (sky sailor) (Wis), Spot (Wis), Survival (Wis), and Use Rope (Dex). Skill totals below include skill synergy bonuses and armor check penalties.

### Green Sailor (“Swabbie”)



Up in the clouds there is an endless supply of young lads who yearn to see the world and put a little excitement under their belt, and they make up the majority of green sailors. A green sailor has been sailing for two years or less. That’s enough time to know what he’s doing, but not enough time to learn the subtleties of the task. The typical ship’s crew is up to 50% green sailors.

**Green Sailor, Sky Elf Exp1 (Sky Sailor):** CR 1/2; Medium humanoid; HD 1d6; hp 3; Init +1; Spd. 30 ft.; AC 12 (+1 Dex, +1 padded), touch 11, FF 11; BAB +0; Grp +0; Atk/Full Atk dagger +0 melee (1d4/19-20) or longbow +1 ranged (1d8/x3); SQ Sky elf traits; AL N; SV Fort +0, Ref +1, Will +2; Str 10, Dex 13, Con 10, Int 10, Wis 10, Cha 9.

*Skills and Feats:* Balance +7, Climb +4, Jump +4, Listen +4, Profession (sky sailor) +4, Search +2, Spot +8, Use Rope +5; Alertness.

*Possessions:* Padded armor, dagger, longbow, 20 arrows, 1d6 sp.

### Experienced Sailor

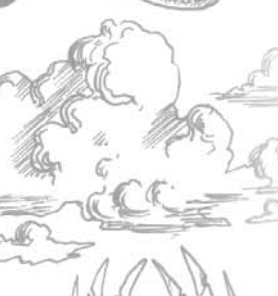

An experienced sailor has chosen a life in the skies. While many green sailors eventually find a wife and settle down somewhere, the experienced sailor has no home but his ship. He gets restless if he’s in the same place for longer than a fortnight. Most crews are roughly 10-30% experienced sailors.

**Experienced Sailor, Sky Elf Exp3 (Sky Sailor):** CR 2; Medium humanoid; HD 3d6; hp 10; Init +2; Spd. 30 ft.; AC 13 (+1 Dex, +1 padded), touch 12, FF 11; BAB +2; Grp +2; Atk/Full Atk dagger +2 melee (1d4/19-20) or longbow +4 ranged (1d8/x3); SQ Sky elf traits; AL N; SV Fort +1, Ref +3, Will +4; Str 10, Dex 14, Con 10, Int 10, Wis 12, Cha 9.

*Skills and Feats:* Balance +10, Climb +6 (+8 to climb ropes), Jump +6, Listen +5, Profession (sky sailor) +7, Search +3, Spot +11 (no penalty for range), Use Rope +8; Alertness, Hawkeyed.

*Possessions:* Padded armor, dagger, longbow, 20 arrows, 1d6 gp.

### Veteran Sailor (“Old Salt”)



A veteran sailor has been sailing the sky lanes since before most of his colleagues were born. He knows all the tricks of the trade. If his personal magnetism were a little stronger, or his situation a little more fortunate, he might have ended up as captain of his own vessel. Veteran sailors make up 10% of an elite crew.

**Veteran Sailor, Sky Elf Exp6 (Sky Sailor):** CR 5; Medium humanoid; HD 6d6; hp 21; Init +2; Spd. 30 ft.; AC 13 (+2 Dex, +1 padded), touch 12, FF 11; BAB +4; Grp +4; Atk/Full Atk dagger +4 melee (1d4/19-20) or longbow +6 ranged (1d8/x3); SQ Sky elf traits; AL N; SV Fort +2, Ref +4, Will +6; Str 10, Dex 15, Con 10, Int 10, Wis 13, Cha 9.

*Skills and Feats:* Balance +12, Climb +6 (+8 to climb ropes), Gather Information +6; Jump +6, Listen +5, Profession (sky sailor) +13, Search +3, Spot +14 (no penalty for range), Survival +6; Use Rope +8; Alertness, Hawkeyed, Skill Focus (Profession [sky sailor]).

*Possessions:* Padded armor, dagger, longbow, 20 arrows, *potion of feather fall*, wrist vial, 3d6 gp.

### Sky Captain



Sky captains come in many forms. Some are cruel tyrants who treat their crews like servants, leading only by virtue of their ownership of the ship. Others are inspiring sailors who climb to a position of leadership through skill, daring, and charisma.

Most but not all captains own their own ships. Those who don’t often make the best captains of them all, for they have to be good at their job in order to stay employed. On the other hand, the owner/operator types tend to be the most daring, since they aren’t constrained by the risk tolerances of the ship’s owner.

Sky captains are iconic NPCs in any aerial adventure, and you should devote special time and effort to make them interesting. After all, players will remember them, and the sky captain is effectively the boss of any sky ship the characters travel on. If you’re stuck for ideas, roll d20 and consult the table on the following page for a bare-bones sky captain background. Then build up a more detailed personality from there.

**Sky Captain, Sky Elf Exp9 (Sky Sailor):** CR 8; Medium humanoid; HD 9d6; hp 31; Init +2; Spd. 30 ft.; AC 14 (+2 Dex, +2 leather), touch 12, FF 12; BAB +6; Grp +6; Atk longsword +6 melee (1d8/19-20) or +1 longbow +9 ranged (1d8+1/x3); Full Atk longsword +6/+1 melee (1d8/19-20) or +1 longbow +9/+4 ranged (1d8+1/x3); SQ Sky elf traits; AL N; SV Fort +3, Ref +5, Will +8; Str 11, Dex 15, Con 10, Int 12, Wis 14, Cha 15.

*Skills and Feats:* Balance +14, Climb +10 (+12 to climb ropes), Gather Information +14, Jump +10, Knowledge (local) +6, Listen +6, Profession (sky sailor) +17, Search +4, Spot +18, Survival +7, Use Rope +12; Alertness, Leadership (base leadership score 11), Skill Focus (Profession [sky sailor]), Sky Captain.

*Possessions:* Leather armor, longsword, dagger, +1 longbow, 20 arrows, *potion of fly* (x3), *ring of feather falling*, *bowl of clouds*, wrist vial, 2d12x10 gp.

### Sky Pirate



Sky pirates come in many shapes and forms. Some are nothing more than sailors who have turned to the wrong side of the law. These pirates have the same stats as sky sailors of similar ability, and they rely on their skills at guiding sky ships to run contraband or outmaneuver prey vessels. But other pirates are little more than thugs. They have limited sailing ability, and the main emphasis of their training is on

# Sky Captain Traits

## Roll Sky Captain Traits

- 1 Drunken lout. The captain stays in his cabin and drinks all day long. He owns the ship so he can't be fired, but his first mate is effectively in charge. The captain loves company and invites passengers to spend the day drinking with him.
- 2 Failed naval officer. The captain had a glorious career until a certain incident occurred. No one knows exactly what happened, but he was dishonorably discharged. Ever since he's sailed his own ship. He rarely speaks.
- 3 Righteous avenger. The captain is militantly devout about ensuring the safety of the sky lanes. He is absolutely lawful and makes a point of chasing down any pirates or monsters he encounters. This unnerves his crew, most of whom would prefer to avoid trouble, and there is regular turnover.
- 4 Pious worshipper. The captain thanks Laelus for the existence of the sky ships that make life in the skies possible. He spends an hour praying every morning and is never without his holy symbol. He is quite insistent that his passengers join him in the morning prayers.
- 5 Cloud bumpkin. The captain grew up on a small, rural cloud village and ended up owning a ship by pure chance – something about finding a crashed ship which he repaired. He's dumb, inattentive, and generally incompetent, but has a great sense of humor and is lots of fun to be around. His ship is piloted by the good ol' boys (good ol' elves?) from his own cloud village, and a trip on his ship is a non-stop party.
- 6 Gentleman smuggler. No one suspects that this straight-laced aristocrat smuggles slaves and drugs in hidden cargo holds. In all respects he seems like a perfect gentleman.
- 7 Condescending jerk. The captain thinks he's far above the common sailor, and even further above the average land-lubber. He prefers not to speak with the crew, as well as any passengers who aren't nobility, and lets his first mate handle all contact. He doesn't treat his crew badly, at least not in terms of physical accommodations, but he makes it clear where they stand.
- 8 Prisoner of his own crew. The captain has the worst bunk on the ship, and his crew practically has free reign. The captain defers to his first mate and spends most of the journey sulking in his bunk. Nobody knows why he doesn't just fire the crew. It's rumored that he once committed a terrible atrocity, which the crew discovered and has since used to blackmail him.
- 9 Cruel tyrant. The captain keeps a whip on his desk, which he uses against sailors who don't complete their tasks fast enough. He takes "the captain is king of his ship" a little too seriously, effectively treating his sailors like serfs while they're in the air. He loses sailors at every port, but always seems to find green locals to take their place. More than two-thirds of his crew has been sailing less than a year.
- 10 Inspiring leader. The captain is a quiet man who commands enormous respect – even admiration – from his crew. He doesn't ask any man to do what he won't do himself. He's always in the front lines of any battle, and in the past has given his own quarters to sick sailors who needed to recover their health. He's never lost a man overboard, and virtually his entire crew has been sailing with him for decades.
- 11 Self-made man (elf?). The captain started out as a lowly sky sailor. He saved every copper he made, learned to sail better than anyone else, and worked his way up to the first mate position. He went in with a group of other like-minded

## Roll Sky Captain Traits

- ed sailors to buy a ship, which they used to haul ore to great profit. Eventually he bought a ship on his own, and now he's captain of his vessel. He never lets the crew forget that he used to be one of them, and can be pretty over-bearing about it at times.
- 12 Daredevil. The captain loves to take risks. He buzzes sky serpents to try to startle them. He flies into thunderstorms just for the excitement. Most of his crew is of the same ilk.
- 13 Explorer. The captain took to the winds primarily to see the world around him. Although he hauls cargo for a living, his main interest is going to new places and seeing new things. He's been known to turn down a lucrative job in favor of a less-profitable trip to a region he's never seen before. He travels slowly, taking the time to stop and document new cloud realms as he comes across them.
- 14 Clouded history. The captain has several huge scars on his face and arms, as well as a more serious injury (eyepatch, pegleg, hook hand, etc.). In a previous career he was an infamous pirate who came upon a magic item that could substantially change his appearance. He used it to leave his life of crime, but there was nothing he could do about the scars and more serious injuries. Now he never speaks of his past.
- 15 Secret agenda. The captain travels the air realms in search of something. He divulges his quest only to those he holds in the strictest confidence; to all others, he seems like an otherwise mundane sky captain. The details of his quest are up to you, but could be to locate a long-fast family member, or find a magical relic which he's heard holds great powers. Perhaps he must fulfill a blood oath to deliver a mysterious parcel he was given 18 years ago, for which he was paid 100,000 gp and threatened with a customized *contingency* spell linked to a curse if he ever opened the parcel or failed to deliver it by the 20th year.
- 16 Retired admiral. The sky captain once commanded an entire fleet. Held in high regard after his retirement, he's parlayed his extensive naval contacts into a successful trading business.
- 17 Swashbuckler. The captain lives fast and loose, always on the move and always looking for adventure. He's just as likely to take a well-paying job as one that has the promise of excitement, and welcomes adventurers to his crew.
- 18 Outsider. The captain is from another plane. He is a skaedrim, tiefling, aasimar, genie, or some other rare type of creature. He was raised on the material plane and is familiar with its customs, and has chosen to adopt a life in the skies.
- 19 Incompetent inheritor. The captain inherited the sky ship from his father. Despite being raised in the sky lanes, he has no talent. He's a terrible airman and an even worse captain. His crew has no respect for him and stays with him only because he pays exceptionally well.
- 20 Death wish. For decades the captain courted a beautiful maiden who lived in a peaceful cloud village not far from here. The village was recently razed by a star dragon. The captain has begun outfitting his ship for battle, and intends to kill the dragon or die trying. His crew has deserted en masse and he's in desperate need of help.



hp 40; Init +2; Spd. 20 ft., fly 40 ft. (good) (3/day, 5 min. each time); AC 18 (+2 Dex, +5 breastplate, +1 buckler), touch 12, FF 16; BAB +8; Grp +10; Atk +1 *keen cutlass* +12 melee (1d8+3/19-20) or dagger +10 melee (1d4+2/19-20) or longbow +10 melee (1d8/x3); Full Atk +1 *keen cutlass* +12/+7 melee (1d8+3/19-20) or dagger +10/+5 melee (1d4+2/19-20) or longbow +10/+5 melee (1d8/x3); SQ Sky elf traits; AL CE; SV Fort +6, Ref +5, Will +7; Str 14, Dex 14, Con 11, Int 10, Wis 13, Cha 14.

**Skills and Feats:** Balance +7, Climb +10 (+12 to climb ropes), Gather Information +12, Jump +0, Knowledge (local) +5, Listen +5, Profession (sky sailor) +9, Search +3, Spot +13, Use Rope +6; Alertness, Leadership (base leadership score 12), Sky Captain, Weapon Focus (cutlass).

**Possessions:** Breastplate armor, +1 *keen cutlass*, buckler, dagger, longbow, 20 arrows, *winged boots*, *potion of feather fall*, *cloak of resistance* +1, wrist vial, 6d12x100 gp

## SKY SERPENT

These sleek, serpentine marauders are wondrous to behold as they soar through the sky but terrible to fight when they are aroused or hungry. An adult sky serpent is a 20 foot long, snake-like creature with a tall, frilled crest that runs down its back. Sages theorize that this crest allows it to soar through the air. Lacking wings or other visible means to fly, the creature merely sways its body in a rhythmic manner to keep itself aloft. Unfortunately, the crest also makes sky serpents practically impossible to ride.

Ancient sky serpents are older specimens that have survived so long that they've outgrown their natural predators. They can reach enormous sizes of up to 50 feet long.

### Combat

Sky serpents use relatively simple tactics to defeat their prey. They gain as much altitude as possible then strike from above, relying on their bite and tail attack to grab, crush, and devour prey. Large swarms of sky serpents have been known to attack leviathans, but these monsters prefer to stalk large birds, rocs, and other, less dangerous prey.

**Improved Grab (Ex):** To use this ability, the sky serpent must hit with its tail attack. If it gets hold, it may constrict its opponent.

**Constrict (Ex):** A sky serpent may crush a grappled opponent in its scaly coils. A grappled creature of up to one size smaller than the sky serpent takes damage equal to its tail attack. In addition, the serpent uses its bite attack. A sky serpent may constrict one foe at a time. While constricting, it may not use its tail attack and gains a +5 circumstance bonus to attacks with its bite against the constricted victim.

hand-to-hand combat. As long as they can get their ship within boarding range of the target vessel, they're satisfied.

As a rule, pirates tend to be higher level than typical sailors. The pirates live in an eat-or-be-eaten environment where strength is necessary to survive. Moreover, they have to be more powerful than their prey in order to prosper. Half the pirates on a typical vessel are experienced sailors, while the rest have the profile below. There are very few green or veteran pirates. The former aren't allowed into the ranks of a pirate ship till they've gained some experience, and the latter are rare because most pirates die before becoming veterans.

**Sky Pirate, Sky Elf Exp2 (Sky Sailor)/War2:** CR 3; Medium humanoid; HD 2d6+2d8; hp 16; Init +1; Spd. 20 ft.; AC 17 (+1 Dex, +5 chainmail, +1 buckler), touch 11, FF 16; BAB +3; Grp +4; Atk/Full Atk cutlass +5 melee (1d8+1/x2) or dagger +4 melee (1d4+1/19-20) or longbow +4 ranged (1d8/x3); SQ Sky elf traits; AL CE; SV Fort +3, Ref +1, Will +4; Str 12, Dex 13, Con 10, Int 9, Wis 12, Cha 9.

**Skills and Feats:** Balance +2, Jump +2, Listen +5, Profession (sky sailor) +6, Search +3, Spot +10, Survival +6; Alertness, Weapon Focus (cutlass).

**Possessions:** Chainmail armor, cutlass, buckler, dagger, longbow, 20 arrows, *potions of jump*, *spider climb*, and *feather fall*, 3d12 gp.

### Sky Pirate Captain

Very few sailors have any desire to meet a sky pirate captain, least of all those who sail with them. Pirate captains are mean, nasty, and spiteful, and they take it out on their crew. But the crew sticks with them for one very good reason: gold, and lots of it. As long as a pirate captain can deliver the booty, his crew will fight for him no matter where he goes.

**Sky Pirate Captain, Sky Elf Exp5 (Sky Sailor)/War5:** CR 9; Medium humanoid; HD 5d6+5d8;

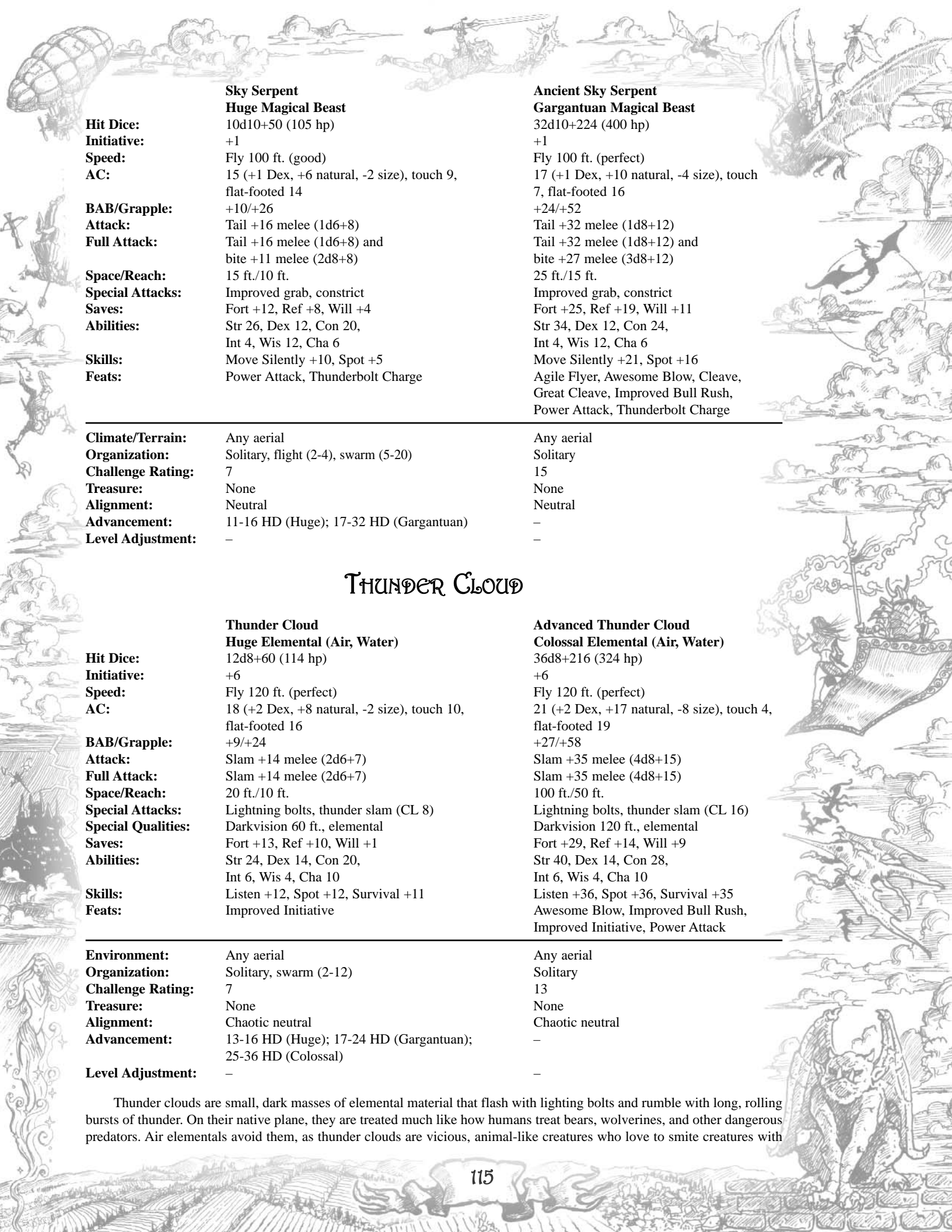

**Sky Serpent  
Huge Magical Beast**

**Hit Dice:** 10d10+50 (105 hp)  
**Initiative:** +1  
**Speed:** Fly 100 ft. (good)  
**AC:** 15 (+1 Dex, +6 natural, -2 size), touch 9, flat-footed 14  
**BAB/Grapple:** +10/+26  
**Attack:** Tail +16 melee (1d6+8)  
**Full Attack:** Tail +16 melee (1d6+8) and bite +11 melee (2d8+8)  
**Space/Reach:** 15 ft./10 ft.  
**Special Attacks:** Improved grab, constrict  
**Saves:** Fort +12, Ref +8, Will +4  
**Abilities:** Str 26, Dex 12, Con 20, Int 4, Wis 12, Cha 6  
**Skills:** Move Silently +10, Spot +5  
**Feats:** Power Attack, Thunderbolt Charge

**Ancient Sky Serpent  
Gargantuan Magical Beast**

**Hit Dice:** 32d10+224 (400 hp)  
**Initiative:** +1  
**Speed:** Fly 100 ft. (perfect)  
**AC:** 17 (+1 Dex, +10 natural, -4 size), touch 7, flat-footed 16  
**BAB/Grapple:** +24/+52  
**Attack:** Tail +32 melee (1d8+12)  
**Full Attack:** Tail +32 melee (1d8+12) and bite +27 melee (3d8+12)  
**Space/Reach:** 25 ft./15 ft.  
**Special Attacks:** Improved grab, constrict  
**Saves:** Fort +25, Ref +19, Will +11  
**Abilities:** Str 34, Dex 12, Con 24, Int 4, Wis 12, Cha 6  
**Skills:** Move Silently +21, Spot +16  
**Feats:** Agile Flyer, Awesome Blow, Cleave, Great Cleave, Improved Bull Rush, Power Attack, Thunderbolt Charge

**Climate/Terrain:** Any aerial  
**Organization:** Solitary, flight (2-4), swarm (5-20)  
**Challenge Rating:** 7  
**Treasure:** None  
**Alignment:** Neutral  
**Advancement:** 11-16 HD (Huge); 17-32 HD (Gargantuan)  
**Level Adjustment:** -

**Climate/Terrain:** Any aerial  
**Organization:** Solitary  
**Challenge Rating:** 15  
**Treasure:** None  
**Alignment:** Neutral  
**Advancement:** -  
**Level Adjustment:** -

## THUNDER CLOUD

**Thunder Cloud  
Huge Elemental (Air, Water)**

**Hit Dice:** 12d8+60 (114 hp)  
**Initiative:** +6  
**Speed:** Fly 120 ft. (perfect)  
**AC:** 18 (+2 Dex, +8 natural, -2 size), touch 10, flat-footed 16  
**BAB/Grapple:** +9/+24  
**Attack:** Slam +14 melee (2d6+7)  
**Full Attack:** Slam +14 melee (2d6+7)  
**Space/Reach:** 20 ft./10 ft.  
**Special Attacks:** Lightning bolts, thunder slam (CL 8)  
**Special Qualities:** Darkvision 60 ft., elemental  
**Saves:** Fort +13, Ref +10, Will +1  
**Abilities:** Str 24, Dex 14, Con 20, Int 6, Wis 4, Cha 10  
**Skills:** Listen +12, Spot +12, Survival +11  
**Feats:** Improved Initiative

**Advanced Thunder Cloud  
Colossal Elemental (Air, Water)**

**Hit Dice:** 36d8+216 (324 hp)  
**Initiative:** +6  
**Speed:** Fly 120 ft. (perfect)  
**AC:** 21 (+2 Dex, +17 natural, -8 size), touch 4, flat-footed 19  
**BAB/Grapple:** +27/+58  
**Attack:** Slam +35 melee (4d8+15)  
**Full Attack:** Slam +35 melee (4d8+15)  
**Space/Reach:** 100 ft./50 ft.  
**Special Attacks:** Lightning bolts, thunder slam (CL 16)  
**Special Qualities:** Darkvision 120 ft., elemental  
**Saves:** Fort +29, Ref +14, Will +9  
**Abilities:** Str 40, Dex 14, Con 28, Int 6, Wis 4, Cha 10  
**Skills:** Listen +36, Spot +36, Survival +35  
**Feats:** Awesome Blow, Improved Bull Rush, Improved Initiative, Power Attack

**Environment:** Any aerial  
**Organization:** Solitary, swarm (2-12)  
**Challenge Rating:** 7  
**Treasure:** None  
**Alignment:** Chaotic neutral  
**Advancement:** 13-16 HD (Huge); 17-24 HD (Gargantuan); 25-36 HD (Colossal)  
**Level Adjustment:** -

**Environment:** Any aerial  
**Organization:** Solitary  
**Challenge Rating:** 13  
**Treasure:** None  
**Alignment:** Chaotic neutral  
**Advancement:** -  
**Level Adjustment:** -

Thunder clouds are small, dark masses of elemental material that flash with lightning bolts and rumble with long, rolling bursts of thunder. On their native plane, they are treated much like how humans treat bears, wolverines, and other dangerous predators. Air elementals avoid them, as thunder clouds are vicious, animal-like creatures who love to smite creatures with





lightning and blast them with thunder. Careful travelers give these creatures a wide berth, but their tendency to be attracted to large fields of magical energy such as those associated with a sky ship make them a frequent danger on the sky ways. The largest thunder clouds are colossal creatures the size of small clouds. They often lurk on the fringes of natural thunderstorms, where they are practically indistinguishable from the normal cloud.

## Combat

Thunder clouds are ornery, angry creatures that attack with little rhyme or reason. Sages theorize that the electrical and sonic energy they contain causes growing discomfort for them, prompting them to seek targets to channel their pain and anger. In battle, a thunder cloud unleashes the fury of the elemental energies it contains. It prefers to blast away at the largest enemies it faces using its lightning bolts and thunder bursts. After exhausting its use of these abilities, it floats away to recharge its energies.

**Lightning Bolt (Su):** A thunder cloud may cast a *lightning bolt* as a sorcerer of the indicated caster level once every 1d4+1 rounds. The thunder cloud may use this attack five times per day.

**Thunder Slam (Su):** The thunder cloud can cause a tremendous clap of thunder, stunning its opponents and dealing sonic damage. It may cast *sound burst* as a sorcerer of the indicated caster level once every 1d4 rounds. The thunder cloud may use this attack five times per day.

**Elemental:** Immune to poison, sleep, paralysis, and stunning. Not subject to critical hits.

## TRADERS (NPCs)

Any trading mission will inevitably see the characters interacting with NPC traders. The traders will vary in ability

and level, but they all have one thing in common: they're dedicated traders. They're considered part of the NPC expert class with maximum ranks in Diplomacy and Profession (trader). The following stat blocks are for traders of four skill levels: young, experienced, veteran, and master. Respectively these correspond to character levels of 4th, 6th, 8th, and 10th. You can see on the table on page 128 which levels tend to trade in which goods.

Traders are skilled at their profession but not particularly good in combat, though they almost always travel armed due to the constant danger of being robbed. Their skill totals include all synergy bonuses, including the +2 bonus to Profession (trader) for 5 or more ranks in Diplomacy. Traders who deal with easily forged items often take ranks in Forgery, though that is not reflected in the stats below.

The class skills for a trader are Appraise, Bluff, Diplomacy, Craft (any one), Forgery, Intimidate, Knowledge (local), Profession (trader), Spot, and Sense Motive.

**Young Trader, sky elf Exp4 (Trader):** CR 3; Medium humanoid (sky elf); HD 4d6; hp 14; Init -1; Spd. 30 ft.; AC 13 (-1 Dex, +4 chain shirt), touch 9, flat-footed 13; BAB +3; Grp +2; Atk shortspear +2 melee (1d6-1/19-20) or thrown dagger +2 ranged (1d4-1/19-20); SA Elven traits; AL N; SV Fort +1, Ref +0, Will +5; Str 8, Dex 9, Con 10, Int 10, Wis 13, Cha 13.

**Skills and Feats:** Appraise +9, Bluff +8, Diplomacy +10, Knowledge (local) +7, Profession (trader) +10, Sense Motive +10, Spot +8; Diligent, Negotiator.

**Possessions:** Chain shirt, shortspear, four daggers, 5,295 gp in cash and goods.

**Experienced Trader, sky elf Exp6 (Trader):** CR 5; Medium humanoid (sky elf); HD 6d6; hp 21; Init -1; Spd. 30 ft.; AC 13 (-1 Dex, +4 chain shirt), touch 9, flat-footed 13; BAB +4; Grp +3; Atk shortspear +3 melee (1d6-1/19-20) or thrown dagger +3 ranged (1d4-1/19-20); SA Elven traits; AL N; SV Fort +2, Ref +1, Will +6; Str 8, Dex 9, Con 10, Int 10, Wis 14, Cha 13.

**Skills and Feats:** Appraise +11, Bluff +12, Diplomacy +12, Intimidate +3, Knowledge (local) +9, Profession (trader) +13, Sense Motive +13, Spot +11; Diligent, Negotiator, Persuasive.

**Possessions:** Chain shirt, shortspear, four daggers, 12,895 gp in cash and goods.

**Veteran Trader, sky elf Exp8 (Trader):** CR 7; Medium humanoid (sky elf); HD 8d6; hp 28; Init -1; Spd. 30 ft.; AC 13 (-1 Dex, +4 chain shirt), touch 9, flat-footed 13; BAB +6; Grp +5; Atk shortspear +5/+0 melee (1d6-1/19-20) or thrown dagger +5/+0 ranged (1d4-1/19-20); SA Elven traits; AL N; SV Fort +2, Ref +1, Will +7; Str 8, Dex 9, Con 10, Int 10, Wis 15, Cha 14.

**Skills and Feats:** Appraise +13, Bluff +15, Diplomacy +15, Intimidate +4, Knowledge (local) +11, Profession (trader) +15, Sense Motive +15, Spot +13; Diligent, Negotiator, Persuasive.

**Possessions:** Chain shirt, shortspear, four daggers, 26,895 gp in cash and goods.

**Master Trader, sky elf Exp10 (Trader):** CR 9; Medium humanoid (sky elf); HD 10d6; hp 35; Init -1; Spd. 30 ft.; AC 13 (-1 Dex, +4 chain shirt), touch 9, flat-footed 13; BAB +7; Grp +6; Atk shortspear +6/+1 melee (1d6-1/19-20) or thrown dagger +6/+1 ranged (1d4-1/19-20); SA Elven traits; AL N; SV Fort +3, Ref +2, Will

+8; Str 8, Dex 9, Con 10, Int 10, Wis 16, Cha 16.

**Skills and Feats:** Appraise +15, Bluff +18, Diplomacy +18, Intimidate +4, Knowledge (local) +13, Profession (trader) +21, Sense Motive +18, Spot +16; Diligent, Negotiator, Persuasive, Skill Focus (Profession [trader]).

**Possessions:** Chain shirt, shortspear, four daggers, 35,895 gp in cash and goods.

## Velda's Mournful Whippoorwill

<b>Hit Dice:</b>	<b>Tiny Construct</b> 1/2d10 (2 hp)
<b>Initiative:</b>	+6
<b>Speed:</b>	10 ft., fly 40 ft. (perfect)
<b>AC:</b>	20 (+6 Dex, +3 natural, +1 size), touch 17, flat-footed 14
<b>BAB/Grapple:</b>	+0/-11
<b>Attack:</b>	Sting +6 melee (1d3-3 and poison)
<b>Full Attack:</b>	Sting +6 melee (1d3-3 and poison)
<b>Space/Reach:</b>	2-1/2 ft./0 ft.
<b>Special Attacks:</b>	Agile attacker, poison
<b>Special Qualities:</b>	Stealthy flier
<b>Saves:</b>	Fort +0, Ref +6, Will +1
<b>Abilities:</b>	Str 4, Dex 23, Con -, Int -, Wis 12, Cha 2
<b>Skills:</b>	Hide +14, Move Silently +10
<b>Environment:</b>	Any
<b>Organization:</b>	Solitary or swarm (3-18)
<b>Challenge Rating:</b>	1
<b>Treasure:</b>	None
<b>Alignment:</b>	Always neutral
<b>Advancement:</b>	None

The accomplished wizard-assassin Velda constructed her mournful whippoorwills to help her slaughter the inhabitants of an entire building or deal with guards and watchmen while she moved into position to eliminate her target. These tiny, mechanical birds are a product of Velda's love of beautiful clockworks and her status as one of the premiere assassins of her time. Though she passed from this plane many years ago, her mechanical creations endure.

The mournful whippoorwill appears as a tiny, mechanical bird forged from brass. Tiny gems are set into its delicate frame, while wings crafted from incredibly thin sheets of mithral give it the ability to fly. The bird's tiny beak ends in a small needle. A repository set into the bird's head is designed to hold poison that is delivered when the bird stabs a victim with its beak. More importantly, the whippoorwill is difficult to spot or hear as it flies towards its target. The intricate mechanisms that drive its wings are well-oiled and specifically crafted to make as little noise as possible, while the bird's tiny size and great agility make it difficult to spot in flight.

### Combat

Normally, a whippoorwill is deployed to eliminate a specific target. The construct is smart enough to seek out a



particular person so long as a drop of its victim's blood or a lock of his hair is placed within a small compartment in the whippoorwill's belly. Otherwise, a whippoorwill can be sent to attack the first person it sees in a specific structure or area. The construct relies on stealth to draw close to its target, as it is small and quiet enough to slip past all but the most alert guards. Evil wizards and clerics love to use these creatures to decimate their enemies, sometimes unleashing small fleets of them upon a castle or rival temple. Other wizards, particularly those with aerial homes, deploy small flights of whippoorwills loaded with paralyzing or sleeping poison to patrol their grounds and the air around them.

**Agile Attacker (Ex):** The mournful whippoorwill is designed to use its speed and agility to deliver its attacks. It buzzes close to a target and with a single pin prick injects a dose of poison. The whippoorwill uses its Dexterity modifier with its melee attacks rather than its Strength modifier.

**Poison (Ex):** The whippoorwill may be loaded with up to five doses of any injury poison. As a default, the venom it carries has a Fortitude save DC of 13 and deals 1d2 Constitution as its initial damage and 1d3 Constitution as its secondary damage.

**Stealthy Flier (Ex):** Due to its special construction and expert design, the mournful whippoorwill gains a +4 bonus to all Move Silently checks. This bonus is included in the stat block listed above.

### Construction

While the mournful whippoorwill lacks the magical complexity and power of a flesh or stone golem, its intricate construction makes building one of these items a daunting task. To create a mournful whippoorwill, a character must first uncover or buy a copy of Velda's Manual of the Shadows. This treatise on assassination includes a detailed description of the process necessary to build a mournful whippoorwill, and costs up to 3,000 gp. Constructing its



body costs 2,000 gp for the tiny parts needed to complete it and a DC 25 Craft (metalworking) check to successfully build the body. The creator must be at least 11th level and have the ability to cast the following arcane spells: *cat's grace*, *fly*, *haste*, *minor creation*, and *reduce*. Finally, to finish the whippoorwill the creator must provide the necessary poison and complete a ritual that drains him of 300 XP.

## WEATHER BANE



**Hit Dice:** 10d10+30 (85 hp)  
**Initiative:** -1  
**Speed:** Fly 30 ft. (good)  
**Armor Class:** 24 (-1 size, -1 Dex, +16 natural), touch 8, flat-footed 24

**Base Attack/Grapple:** +7/+17  
**Full Attack:** Blades +13 melee (3d6+6)  
**Attack:** Blades +13 melee (3d6+6)  
**Space/Reach:** 10 ft./5 ft.  
**Special Attacks:** Lightning, spell-like abilities  
**Special Qualities:** Damage reduction 5/magic, construct traits, blindsense, climate control, electrical absorption, optional abilities

**Saves:** Fort +3, Ref +2, Will +6  
**Abilities:** Str 23, Dex 8, Con -, Int -, Wis 16, Cha 1

---

**Environment:** Any  
**Organization:** Solitary  
**Challenge Rating:** 7  
**Treasure:** None  
**Alignment:** Always neutral  
**Advancement:** 11-20 (Large), 21-30 (Huge)  
**Level Adjustment:** -

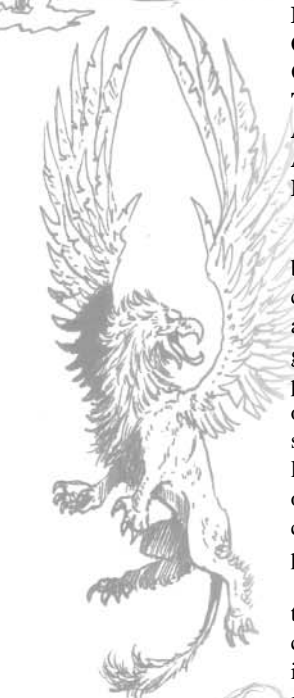

Born of metalcraft and animated by sorcery, weather banes are magical contrivances. Although their size and components can differ from one to another, they all resemble a simple clockwork mechanism. The primary body is a large gear within which smaller gears turn, even without springs to power them. Like misplaced hour and minute hands, two ornate spires extend from the central gear. The smaller of the spires rises from the top, pointing to the heavens, while the larger protrudes down from below. Both always rotate in opposite directions, but these are not for use in combat. For close-quarter defense, weather banes are equipped with a pair of spinning blades that are mounted on a crane-like arm.

Although they can be endowed with additional abilities, the primary function of the weather bane is to manipulate the climate. Some wizards manufacture them to guard their residences from storms and other less-natural hazards. Other more enterprising individuals may use them to offer services to territories that are blighted by drought. Still, there are many more unscrupulous sorts that loose the weather bane's power upon settlements or denizens of the skies, hurling lightning bolts from a sudden storm.

Weather banes are without minds of their own and must be instructed like a golem, but while they cannot set their own goals they have more assets to use in fulfilling their tasks.

## Combat

The way in which weather banes fight is to a large degree up to the planning of its master, although there are restrictions on their abilities that must be adhered to. Most abilities can only be used with limited frequency, so for a weather bane to be most effective it will alternate its tactics from round to round, using both spells and melee attacks.

**Lightning (Sp):** As a full round action, weather banes can fire a bolt of lightning as per the *lightning bolt* spell, where the caster level equals the weather bane's HD. In thunderstorms this can be done every other round, but in other conditions it can only be done once every five rounds.

**Blindsense (Ex):** Weather banes can "see" and "hear" perfectly well through weather of any kind.

**Climate Control (Sp):** Weather banes can manipulate the climate as per the *control weather* spell (caster level is the weather bane's HD) with the following exceptions:

- The weather bane is always at the center of the weather pattern.
- The weather bane is immune to all ill effects of the weather it creates.
- As per the spell's usual effects it takes the weather bane 10 minutes to change the weather, but it is free to take other actions in the meantime.
- If the weather bane is disabled or destroyed, the artificial weather conditions it created will clear up in 10 minutes.

**Spell-like Abilities (Sp):** As a standard action, weather banes can cast *fog cloud* and *gust of wind*, with caster level equal to their HD. There is no limit to how many times they can do this.

**Electrical Absorption (Su):** Weather banes are completely immune to damage from electrical attacks. Moreover, they automatically absorb the power of such attacks and can return them as lightning bolts. From the time of absorption, a weather bane has until its next turn to release the charge (as a *lightning bolt* spell but the damage is equal to what has been absorbed) as a standard action. An unreleased charge dissipates harmlessly after the weather bane's turn. As a free action, a weather bane can attempt to absorb any electrical effect that passes nearby, even if it isn't the target. The maximum range for this is 99 feet with a success chance of 100% minus 1% per foot of distance between the electricity and the weather bane.

**Optional Abilities:** Advanced weather banes may have additional powers bestowed upon them as described in the construction section below.

## Construction

Manufacturing a weather bane requires 1,500 pounds of steel and copper. One of the following checks must be made: Craft (blacksmith) (DC 18), Craft (armorsmith) (DC 21), or Craft (weaponsmith) (DC21). CL 15; Craft Construct, *control weather*, *fog cloud*, *fly*, *geas/quest*, *gust of wind*, *lightning bolt*, *polymorph any object*; caster must be at least 15th level. Price: 80,000 gp, cost: 40,000 gp + 3,200 XP. A weather bane can be created with additional HD at the price of 8,000 gp for each additional HD.

**Advanced Weather Bane Powers:** For every second hit die above 10 that a weather bane has at creation (e.g., on its 12th HD, its 14th HD, its 16th HD, etc.), its maker can



bestow one of the abilities below.

**Extra Blade Attack:** More spinning blades can be attached to a weather bane, giving it an additional melee attack. Up to three extra sets of blades can be attached, each granting another unpenalized attack.

**Repulsion:** In a manner opposite that of magnetism, the weather bane can freely create a force that repels ferrous metals. All metal-based missile attacks (including arrows with metal arrowheads) made against the weather bane suffer a -4 attack penalty while metal melee attacks suffer a -2 penalty. Metal-based creatures and characters wearing metal armor must make a Strength check (DC 15) to push their way to within 10 feet of the weather bane, and must keep making the check every round or be forced 10 feet away from it.

**Shield Array:** A number of shields rotate about the weather bane, making it more difficult to hit from any direction and increasing its natural armor bonus to AC by +4.

**Spells:** The weather bane can be given five levels worth of spells taken in any combination from the following: *chain lightning*, *dispel magic*, *fireball*, *glitterdust*, *ice storm*, *magic missile*, *resist elements*, or *wind wall*. Each spell selected can be cast once per hour with the weather bane's HD as the caster level. The same spell can be selected multiple times, increasing the number of times it can be cast per hour. The spells added to the weather bane must be cast as part of its creation.

## WINGED BORER

<b>Hit Dice:</b>	Medium Magical Beast 1d10+1 (6 hp)
<b>Initiative:</b>	+2
<b>Speed:</b>	30 ft., fly 80 ft. (average)
<b>AC:</b>	15 (+2 Dex, +3 natural), touch 12, flat-footed 13
<b>BAB/Grapple:</b>	+1/+2
<b>Attack:</b>	Bite +2 melee (1d8+1)
<b>Full Attack:</b>	Bite +2 melee (1d8+1)
<b>Space/Reach:</b>	5 ft./5 ft.
<b>Special Attacks:</b>	Wood borer
<b>Saves:</b>	Fort +4, Ref +5, Will +0
<b>Abilities:</b>	Str 12, Dex 15, Con 13, Int 5, Wis 10, Cha 10
<b>Skills:</b>	Hide +7, Spot +5

<b>Environment:</b>	Temperate forest and aerial
<b>Organization:</b>	Flock (2-20)
<b>Challenge Rating:</b>	1/2
<b>Treasure:</b>	None
<b>Alignment:</b>	Always neutral
<b>Advancement:</b>	2-5 HD (Medium), 6-10 HD (Large)

The bane of sky ships, the winged borer is a worm-like creature that feasts upon wood. In its natural habitat, the borer burrows into and devours trees. These creatures are common in large woods and are sometimes used by druids to control a forest's growth. However, some of these creatures wander high in the atmosphere and pose a deadly threat to sky ships constructed of wood. In such cases, the winged borer loves to fly beneath a ship and eat holes into its hull from below.

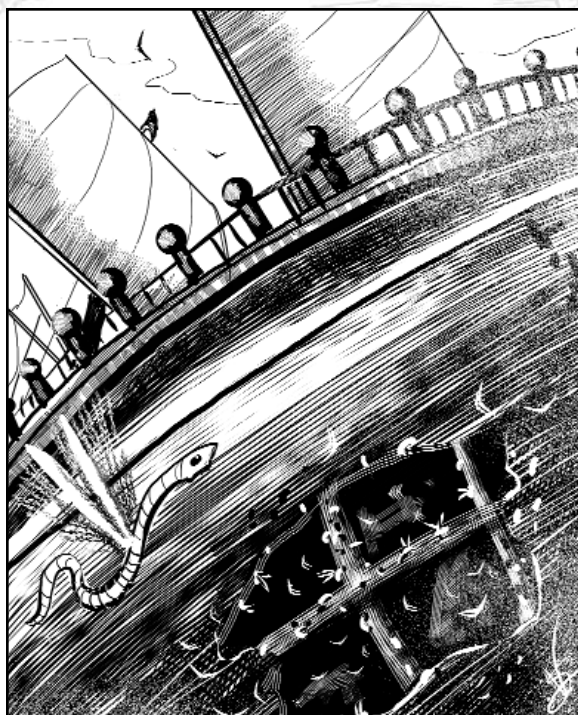

Winged borers look like earthworms with long, sleek, bat-like wings set halfway down their long, sinuous bodies. They have three coal-black eyes set above a circular mouth similar to a lamprey's. When feeding, the winged borer attaches to a tree or ship and uses its many teeth to grind wood down into a thick pulp it quickly consumes.

### Combat

While winged borers never eat flesh, they are quite territorial and jealous of their feeding grounds. Thus, they may attack humans and other travelers who venture into their territory. A winged borer in the midst of feeding, such as one tearing holes into a sky ship, invariably attacks anyone who dares interrupt its activities.

**Wood Borer (Ex):** A winged borer's digestive system is highly adapted to devouring wood. When the borer attacks a wooden object with its bite, it ignores its target's hardness rating. The wood borer's teeth easily saw through wood and its digestive juices quickly turn it into a wet, pulpy soup.

## WINGED CREATURE (TEMPLATE)

Winged creatures dwell on the elemental plane of air and in the upper reaches of the sky. They resemble creatures found on the material plane and generally look like a normal creature that has grown wings.

The winged template is designed as a quick and easy way to import monsters to the aerial setting. Winged trolls, ogres, giants, and other monsters can provide adversaries for adventurers who travel the skies. For more powerful winged enemies, consider using the half-fiend template from the MM.



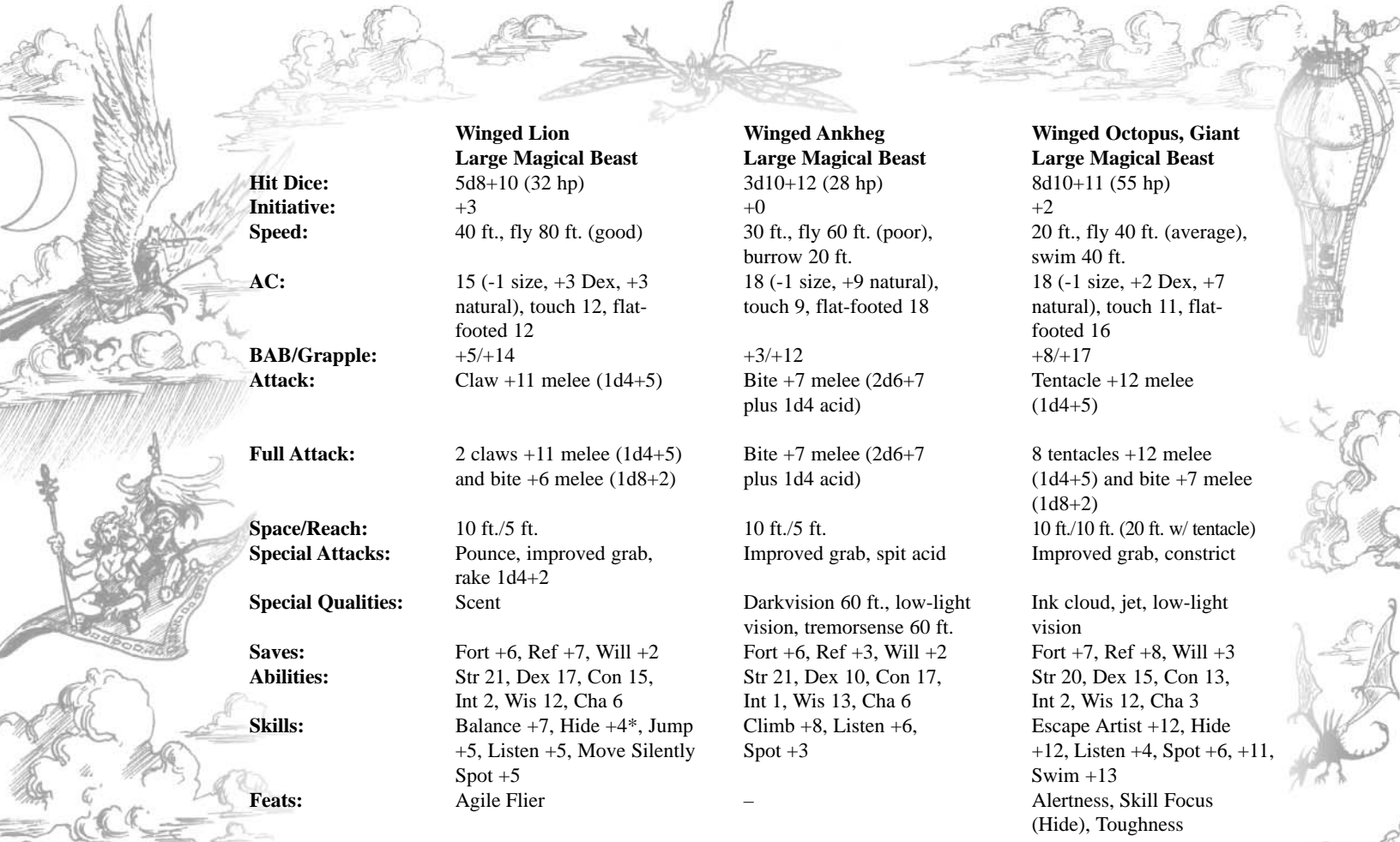

	<b>Winged Lion</b> <b>Large Magical Beast</b>	<b>Winged Ankh</b> <b>Large Magical Beast</b>	<b>Winged Octopus, Giant</b> <b>Large Magical Beast</b>
<b>Hit Dice:</b>	5d8+10 (32 hp)	3d10+12 (28 hp)	8d10+11 (55 hp)
<b>Initiative:</b>	+3	+0	+2
<b>Speed:</b>	40 ft., fly 80 ft. (good)	30 ft., fly 60 ft. (poor), burrow 20 ft.	20 ft., fly 40 ft. (average), swim 40 ft.
<b>AC:</b>	15 (-1 size, +3 Dex, +3 natural), touch 12, flat-footed 12	18 (-1 size, +9 natural), touch 9, flat-footed 18	18 (-1 size, +2 Dex, +7 natural), touch 11, flat-footed 16
<b>BAB/Grapple:</b>	+5/+14	+3/+12	+8/+17
<b>Attack:</b>	Claw +11 melee (1d4+5)	Bite +7 melee (2d6+7 plus 1d4 acid)	Tentacle +12 melee (1d4+5)
<b>Full Attack:</b>	2 claws +11 melee (1d4+5) and bite +6 melee (1d8+2)	Bite +7 melee (2d6+7 plus 1d4 acid)	8 tentacles +12 melee (1d4+5) and bite +7 melee (1d8+2)
<b>Space/Reach:</b>	10 ft./5 ft.	10 ft./5 ft.	10 ft./10 ft. (20 ft. w/ tentacle)
<b>Special Attacks:</b>	Pounce, improved grab, rake 1d4+2	Improved grab, spit acid	Improved grab, constrict
<b>Special Qualities:</b>	Scent	Darkvision 60 ft., low-light vision, tremorsense 60 ft.	Ink cloud, jet, low-light vision
<b>Saves:</b>	Fort +6, Ref +7, Will +2	Fort +6, Ref +3, Will +2	Fort +7, Ref +8, Will +3
<b>Abilities:</b>	Str 21, Dex 17, Con 15, Int 2, Wis 12, Cha 6	Str 21, Dex 10, Con 17, Int 1, Wis 13, Cha 6	Str 20, Dex 15, Con 13, Int 2, Wis 12, Cha 3
<b>Skills:</b>	Balance +7, Hide +4*, Jump +5, Listen +5, Move Silently Spot +5	Climb +8, Listen +6, Spot +3	Escape Artist +12, Hide +12, Listen +4, Spot +6, +11, Swim +13
<b>Feats:</b>	Agile Flier	—	Alertness, Skill Focus (Hide), Toughness
<b>Environment:</b>	Warm plains, aerial	Warm plains, aerial	Warm aquatic, aerial
<b>Organization:</b>	Solitary, pair, pride (6-10)	Solitary or swarm (2-50)	Solitary
<b>Challenge Rating:</b>	4	4	9
<b>Treasure:</b>	None	None	None
<b>Alignment:</b>	Always neutral	Always neutral	Always neutral
<b>Advancement:</b>	6-8 HD (Large)	4 HD (Large), 5-9 HD (Huge)	9-12 HD (Large), 13-24 HD (Huge)
<b>Level Adjustment:</b>	—	—	—

### WINGED LION

Winged lions are a naturally occurring subspecies of standard lions. They are found in lands of great magical concentrations, including cloud realms.

#### Combat

**Pounce (Ex):** If a winged lion leaps upon a foe during the first round of combat, it can make a full attack even if it has already taken a move action.

**Improved Grab (Ex):** To use this ability, the winged lion must hit with its bite. If it gets a hold, it can rake.

**Rake (Ex):** A winged lion that grabs a creature can make two rake attacks at +7 to hit for 1d4+2 damage each. The winged lion may also use these attacks if it uses its pounce ability.

**Skills:** Winged lions receive a +4 racial bonus to Balance, Hide, and Move Silently checks.

### WINGED ANKHEG

In the final stage of an ankh's life, the creature enters an extended period of pupation. When it emerges, a pair of flimsy wings have sprouted from its abdomen. The ankh then takes to the air in search of a mate.

Not all ankh's go through this final developmental stage, but those that do seem to experience it at the same time. Sages do not know what triggers these periods of mass pupation, but it is an undisputed fact that once every few decades, vast numbers of ankh's develop wings and take to the air in terrible swarms, devouring crops and livestock wherever they travel. Even though they are poor flyers, they have been known to make it into the cloud realms when the winds are right.

#### Combat

**Improved Grab (Ex):** To use this ability, the winged ankh must hit with its bite. If it can then attempt to start a grapple as a free action.

**Spit Acid (Ex):** 30-ft. line, once every 6 hours; damage 4d4 acid, Reflex DC 14 half. One such attack depletes the

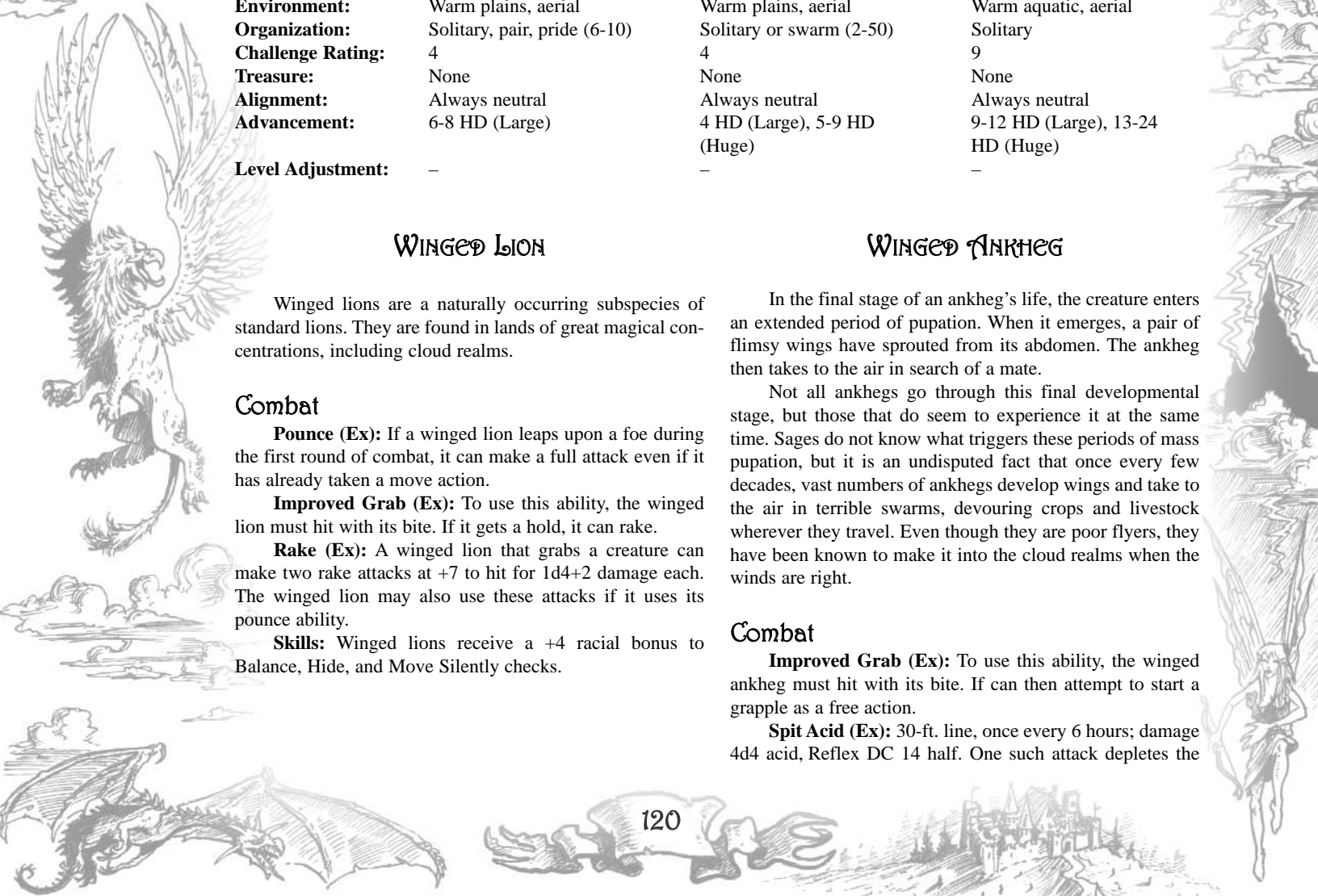

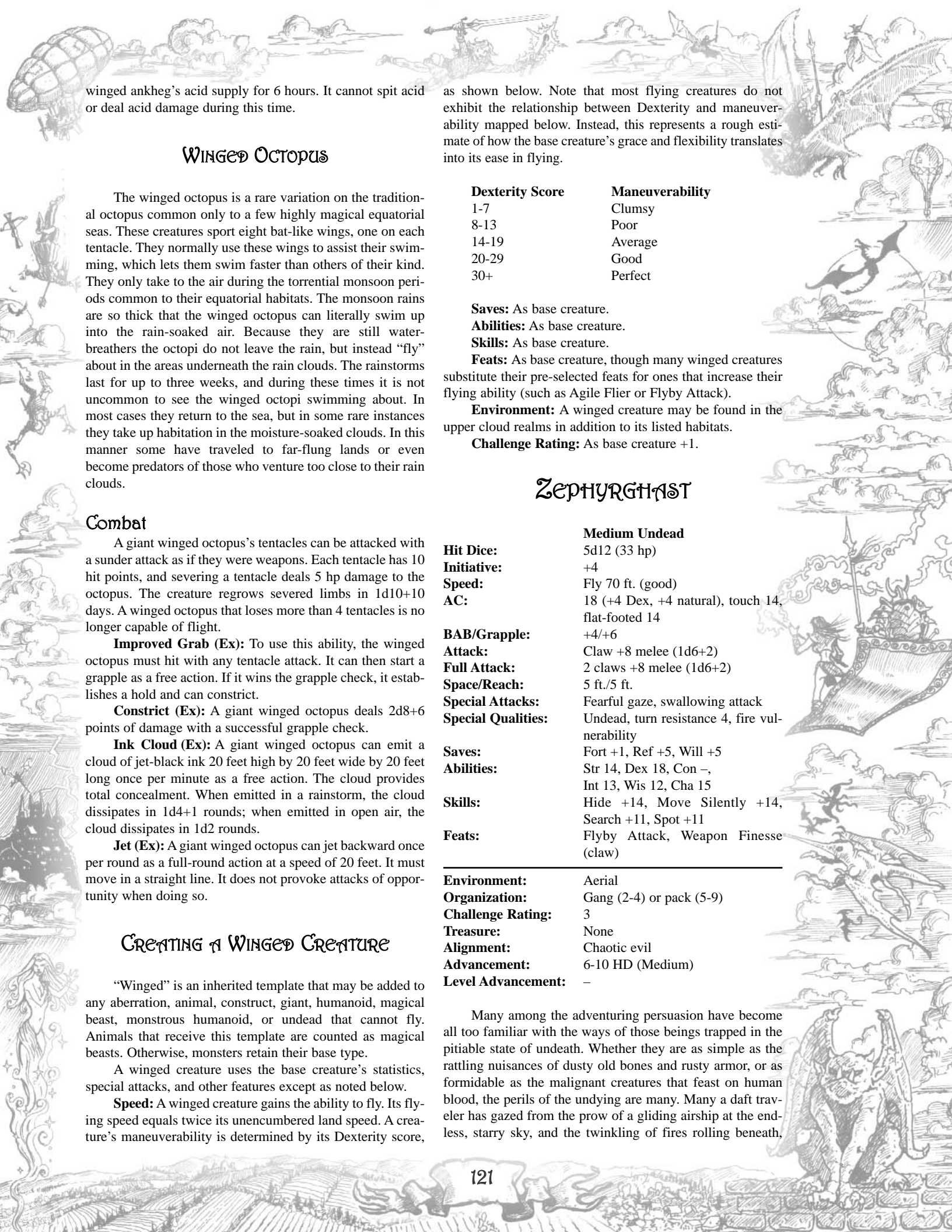

winged ankheg's acid supply for 6 hours. It cannot spit acid or deal acid damage during this time.

## WINGED OCTOPUS

The winged octopus is a rare variation on the traditional octopus common only to a few highly magical equatorial seas. These creatures sport eight bat-like wings, one on each tentacle. They normally use these wings to assist their swimming, which lets them swim faster than others of their kind. They only take to the air during the torrential monsoon periods common to their equatorial habitats. The monsoon rains are so thick that the winged octopus can literally swim up into the rain-soaked air. Because they are still water-breathers the octopi do not leave the rain, but instead "fly" about in the areas underneath the rain clouds. The rainstorms last for up to three weeks, and during these times it is not uncommon to see the winged octopi swimming about. In most cases they return to the sea, but in some rare instances they take up habitation in the moisture-soaked clouds. In this manner some have traveled to far-flung lands or even become predators of those who venture too close to their rain clouds.

### Combat

A giant winged octopus's tentacles can be attacked with a sunder attack as if they were weapons. Each tentacle has 10 hit points, and severing a tentacle deals 5 hp damage to the octopus. The creature regrows severed limbs in 1d10+10 days. A winged octopus that loses more than 4 tentacles is no longer capable of flight.

**Improved Grab (Ex):** To use this ability, the winged octopus must hit with any tentacle attack. It can then start a grapple as a free action. If it wins the grapple check, it establishes a hold and can constrict.

**Constrict (Ex):** A giant winged octopus deals 2d8+6 points of damage with a successful grapple check.

**Ink Cloud (Ex):** A giant winged octopus can emit a cloud of jet-black ink 20 feet high by 20 feet wide by 20 feet long once per minute as a free action. The cloud provides total concealment. When emitted in a rainstorm, the cloud dissipates in 1d4+1 rounds; when emitted in open air, the cloud dissipates in 1d2 rounds.

**Jet (Ex):** A giant winged octopus can jet backward once per round as a full-round action at a speed of 20 feet. It must move in a straight line. It does not provoke attacks of opportunity when doing so.

## CREATING A WINGED CREATURE

"Winged" is an inherited template that may be added to any aberration, animal, construct, giant, humanoid, magical beast, monstrous humanoid, or undead that cannot fly. Animals that receive this template are counted as magical beasts. Otherwise, monsters retain their base type.

A winged creature uses the base creature's statistics, special attacks, and other features except as noted below.

**Speed:** A winged creature gains the ability to fly. Its flying speed equals twice its unencumbered land speed. A creature's maneuverability is determined by its Dexterity score,

as shown below. Note that most flying creatures do not exhibit the relationship between Dexterity and maneuverability mapped below. Instead, this represents a rough estimate of how the base creature's grace and flexibility translates into its ease in flying.

Dexterity Score	Maneuverability
1-7	Clumsy
8-13	Poor
14-19	Average
20-29	Good
30+	Perfect

**Saves:** As base creature.

**Abilities:** As base creature.

**Skills:** As base creature.

**Feats:** As base creature, though many winged creatures substitute their pre-selected feats for ones that increase their flying ability (such as Agile Flier or Flyby Attack).

**Environment:** A winged creature may be found in the upper cloud realms in addition to its listed habitats.

**Challenge Rating:** As base creature +1.

## ZEPHYRGHAST

<b>Hit Dice:</b>	Medium Undead 5d12 (33 hp)
<b>Initiative:</b>	+4
<b>Speed:</b>	Fly 70 ft. (good)
<b>AC:</b>	18 (+4 Dex, +4 natural), touch 14, flat-footed 14
<b>BAB/Grapple:</b>	+4/+6
<b>Attack:</b>	Claw +8 melee (1d6+2)
<b>Full Attack:</b>	2 claws +8 melee (1d6+2)
<b>Space/Reach:</b>	5 ft./5 ft.
<b>Special Attacks:</b>	Fearful gaze, swallowing attack
<b>Special Qualities:</b>	Undead, turn resistance 4, fire vulnerability
<b>Saves:</b>	Fort +1, Ref +5, Will +5
<b>Abilities:</b>	Str 14, Dex 18, Con -, Int 13, Wis 12, Cha 15
<b>Skills:</b>	Hide +14, Move Silently +14, Search +11, Spot +11
<b>Feats:</b>	Flyby Attack, Weapon Finesse (claw)

---

<b>Environment:</b>	Aerial
<b>Organization:</b>	Gang (2-4) or pack (5-9)
<b>Challenge Rating:</b>	3
<b>Treasure:</b>	None
<b>Alignment:</b>	Chaotic evil
<b>Advancement:</b>	6-10 HD (Medium)
<b>Level Advancement:</b>	-

Many among the adventuring persuasion have become all too familiar with the ways of those beings trapped in the pitiable state of undeath. Whether they are as simple as the rattling nuisances of dusty old bones and rusty armor, or as formidable as the malignant creatures that feast on human blood, the perils of the undying are many. Many a daft traveler has gazed from the prow of a gliding airship at the endless, starry sky, and the twinkling of fires rolling beneath,



and felt secure that the purity of this place could never be tainted by the cursed touch of the undead. This is most often the time for a pack of zephyrghasts to swoop down and consume said individual, foolish assumptions and all.

It has been speculated that zephyrghasts are the results of the abhorrent practice by some sky ship captains of “tattering” insubordinate crewmen and especially hated prisoners. Tattering consists of binding the unfortunate and dangling him from the ship with a goodly amount of rope. The ship is then steered low to the ground and the victim finds himself being dragged across sharp mountain faces and through clawing forests. This is done until the individual has been utterly broken, whereupon they are left to dangle and die in agony. Legend states that the more vengeful of these individuals manage to spitefully cling to their last shred of life, and animate their broken corpses, freshly consumed by a desire to devour and destroy.

A chill biting wind and hollow shrieking heralds the arrival of the zephyrghasts, always under cover of night. Knowledgeable folk draw a weapon and become right wary of their environment; smart folk head behind a nice sturdy door and wait for the ill winds to blow over and take their macabre passengers with them. When on the hunt, zephyrghasts wheel about, shrieking amongst themselves, seeking out victims to satiate their hunger. These windborne abominations are truly frightful to behold. Commonly, only the arms, shoulders and head of a zephyrghast remain, the remnants of their battered bodies hanging in pale leathery tatters among the rags of clothes they wore in life, giving them the appearance of a poorly used rag doll. Their flesh is pale and drawn tight over their faces and arms, giving them a skeletal appearance. Their hands are long-fingered and sinewy, and each fingertip ends in a thick, yellowed nail as hard as any dagger. The eyes have become little more than black pits that burn with pinpoints of yellow light – some say these are the fires of their vengeance.

Once potential meals have been selected, the creatures dart in and attack by raking with their jagged nails, then dart out again, favoring tactics that wear down their prey. They themselves never seem to tire, and have been known to harry

a being for hours on end to grind them down enough for the kill. Complicating matters even further, anyone unfortunate enough to meet the cold gaze of the zephyrghast more often than not finds him or herself in an uncontrollable panic, and proceeds to exhaust himself in frantic efforts to evade consumption. Those stout of heart are less likely to be affected, and can have a great deal of influence in helping to keep their comrades from running mad. But even more insidious than the maddening they cause is their singularly disturbing habit of abruptly swallowing meals whole, from the most diminutive of damsels, to the largest of brutes. Should a zephyrghast succeed in striking with both arms, the mouth will open obscenely wide, and the creature will proceed to stuff its victim down its gullet. Their ragged bodies immediately gather some substance, and their movements become prominently slower. In this condition, the monstrosity merely seeks to fly off to digest its meal. The victim, however, finds himself trapped and barely able to move, and losing strength at a steady rate. The individual may try to burst free, but as they are slowly drained this becomes harder and harder, not to mention slightly inconvenient should one find themselves a few thousand feet above the ground. It is quite possible for one’s comrades to come their aid, but there is a risk that the consumed may be injured as well as the zephyrghast.

As well as being tireless and fearful, the zephyrghasts all enjoy an immunity to steel of a mundane nature. Most blades seem to merely push their tattered “bodies” aside, and bounce off the sallow face and arms. It should give the individual heart to note, however, that weapons of exceptional fashion and even the slightest of enchantments will damage them. In addition, fire is the zephyrghast’s worst enemy. If struck well enough they will go up like a pile of dry kindling, flying off into the night screeching and cursing on the wind.

## Combat

Zephyrghasts fly through supernatural means.

**Fearful Gaze (Su):** This has the same effects as a *fear* spell but is treated as a gaze attack. It has a range of 30 feet and the target must make a Will save to resist (DC 19 initially; if in the presence of others that have made their save already this is reduced to DC 14). The save DC is Charisma-based and initially has a +5 bonus to DC thanks to the frightful nature of the zephyrghast.

**Swallowing Attack (Ex):** When the zephyrghast succeeds in a grapple attack against a creature of Medium size or smaller, it automatically draws the victim into its mouth to be swallowed whole (yes, whole). The creature winds up in the zephyrghast’s gullet. While in the gullet the victim loses 1 point of Strength per round (Fort DC 15 to negate, made each round). Escaping the gullet requires a single great Strength check (DC 25) or inflicting 15 points of damage (AC 14) with a light slashing or piercing weapon.

It is possible for the consumed individual to be cut out by comrades but every hit the creature suffers causes full damage to the zephyrghast and an additional half damage to the individual inside (Ref save DC 20 to avoid).

**Undead:** Immune to mind influencing effects, poison, sleep, paralysis, stunning, and disease. Not subject to critical hits, nonlethal damage, ability damage, energy drain, or death from massive damage.

**Fire Vulnerability:** Zephyrghasts take double damage from fire-based attacks. Heat attacks do no extra damage.



## Chapter Six

# Running Aerial Adventures

Player options, skyship stats, aerial combat rules, and monsters galore: you now have all the tools you need to build an aerial campaign. Only one question remains: What do you build with them? This section discusses ways to run aerial adventures, how to structure aerial campaigns, and generally how to use the material in this book.

## Aerial Campaigns

Aerial campaigns come in two basic varieties: ground-based and air-based. Ground-based campaigns usually begin as traditional fantasy campaigns. If you're planning to integrate this book into an ongoing game, then you'll be running a ground-based campaign. In this situation, the aerial realms take on a magical, exotic feel. The characters have adventured for months or even years without so much as hearing of cloud cities, much less visiting them. When contact with the air begins, the initial focus is usually exploration. Only after the characters have played with the novelty of skyships and cloud cities for some time do they begin to partake in full-fledged aerial adventuring.

Air-based campaigns, on the other hand, start off with the players living on a skyship or in a cloud city. In these adventures, the existence of the air realms is taken for granted. There's less need for exploration. Instead, these adventures focus more on trade or conquest. In some cases, exploration can be a big focus, but the emphasis is on the mysterious surface world below.

## Ground-based Campaigns

The default assumption for much of this book is that you are running a ground-based campaign. You're probably introducing the air realms to a group of players who have already spent some time exploring the surface of your campaign world. Little do they know that another realm of adventure awaits above!

The introduction of air travel to a ground-based campaign has huge implications. How you handle these implications determines the adventures the characters will have. The early stages of the characters' involvement with cloud cities will invariably have them investigating the sky lanes, getting to know cities and NPCs, and generally learning as much as they can. This is a good time to give them exploration-style adventures. Exploration missions introduce them to the basic concepts of aerial adventuring while also providing the opportunity to be a hero.

Remember that the surface-world characters are just as novel to the airborne races as sky ships are to the landlubbers. The mere existence of the PCs in a sky elf city or aboard an air skiff raises all sorts of questions. Can the surface-dwellers talk? Why are they here? What is their magic like? How did they learn of us? The PCs will be looked upon

as emissaries of their peoples, which can be quite a load on the shoulders of the typical kick-in-the-door adventurer. While children at the street gawk at the land-dwelling dwarves and gnomes they've heard stories of but never before seen, those same dwarves and gnomes are invited to every important social function that occurs. Not only are they the subject of gossip, but they're also perceived as being quite powerful. How else could they make their way to the skies? Existing political factions seek alliances with this new, unknown camp, or at least try to break up potential alliances with their enemies. At the same time, sky captains, the military, guilds, and even local pirates may be interested in recruiting a powerful new employee or ally.

The characters can be tossed into a morass of competing interests before they know what's going on. This is a great way to hook them into exploration missions. Those exploration missions can then expand on the political nature of the cloistered, close-knit cloud cities. After each foray into the unknown, the characters return to find their reputations changed by what they did and who they did it for. For example, by accepting a mission from a tradesman interested in finding stable clouds for use as waystations, they may be marked as enemies by his competitors, who have ties to sky pirates. When they embark on their next exploration mission, they're suddenly the victims of piracy. Once they finally hunt down the pirates, they discover that the pirate captain is in fact one of the noble houses' eldest sons, moonlighting from his boring governmental post. Do they slay him, turn him in, or blackmail him?

Once the novelty of exploration begins to fade, it's time to introduce the next stage of aerial adventuring. By now the characters should be familiar with the basic plots and personalities of the skies. So send them into the fray! Give them some conquest and combat missions, where they learn the ins and outs of ship-to-ship combat. Give them the chance to track down pirates and make daring leaps from one ship to another. Allow for aerial rescues as innocent victims fall overboard, and dramatic ranged combats between fleets of pegasus riders and bat-mounted orcs. Don't forget to use aerial NPCs (like classed arachnids and half-fiend orcs) to get the characters emotionally involved in the affairs of the sky. There's nothing like a good villain to stir a player's heart.

As you move the campaign forward, keep in mind one all-important fact: The characters have radically changed the nature of ties between the surface and aerial realms. Their





mere presence in the sky sends shockwaves through aerial society. At least one aerial adventurer will decide that if the PCs can visit his realm, why can't he visit theirs? It is only a matter of time before a sky ship touches down in the exact same land-based city that the PCs used to adventure in.

Thus, the ultimate goal of an aerial campaign should be to move the action toward a resolution that somehow impacts the surface world. There are three reasons for this. First, players exploring the air will eventually start to wonder what's happening to the world below. They'll probably want to go back at some point regardless. Second, they'll eventually get bored of straight aerial campaigns. Sky ships have a strong allure, but it doesn't last unless you keep it fresh. Finally, it doesn't make sense for your campaign to not impact the surface world. If the NPCs in your world really have genuine motivations and interests, it's inevitable that they'll decide to journey to the mysterious place from which the PCs came. You might as well include this event as part of the situation the PCs will have to face.

This seminal event – when air meets earth – marks the culmination of an aerial campaign. It is the point where the simple concept of air travel goes from “ooh, neat! airships!” to a world-changing event. Although you can contrive to prevent this from happening (perhaps religious taboos prevent the air-dwellers from ever touching the earth, or some sort of magic prevents the characters from ever returning), by doing so you effectively transform the magical cloud realms into a completely mundane place. Don't ever let air travel become normal; don't let the players take it for granted. The best way to keep it fantastic is to eventually force the PCs to confront it through the eyes of the rest of their land-locked society.

## Introducing Sky Ships



The biggest challenge that faces a ground-based campaign is introducing sky ships in the first place. Unless you want to radically change the world your players know, you have to introduce air travel in a manner where it can't become widespread. In fact, not only must the travel itself not become widespread, but the mere knowledge that such travel can exist must not become widespread. Many a mage has dreamed of flying, a dream they satisfied with the *fly* spell – but once it becomes common knowledge that long-range flight with massive cargo-carrying capacity is possible with magic sailing vessels, that *fly* spell won't seem like enough. At least one mage is guaranteed to begin serious research into how such a thing can be possible. Likewise, at least one king or warlord will recognize the military implications of fleets of skyships, and he'll set his best court wizard to work on the project whether the wizard likes it or not.

To avoid such revolutions – or at least to avoid them until your players have explored the air realms and you're ready for a plot that involves earth-to-sky contact – you should introduce air travel in a way that minimizes overall contact. Here are some ways to do it:

- There's the old classic, having an air ship crash in front of the characters. If you do this, make sure the characters are in a remote region where no one else will witness the crash. Make the air ship salvageable, so it's

repaired and sent back to the sky before any surface mages can study it, or else have it be completely destroyed. A fire or a crash into the ocean are both ways to ensure the wreck goes unrecovered. This also challenges the characters with finding a way to get to the clouds. Perhaps the survivors of the crash hire the characters to help them build a new ship.

- If the characters are passing through an alpine area, arrange for them to make contact with high-altitude avians or dwarves who routinely trade with sky ships. They live in a peak so high it's above the cloud line. Approaching sky ships are thus unnoticed by those at the base of the mountain. The mountainside itself is so steep that the only way to reach the alpine settlement is by way of underground tunnels.
- A gate or teleportation circle in an ancient, ruined dungeon might connect to a cloud realm. Imagine the players' surprise when they walk through and suddenly see open sky all around them. Imagine their further surprise when they learn the gate was one-way only. And imagine still further astonishment when they learn that the cloud city they now occupy is also in ruins, much like the earthen dungeon they were in. Whoever built both places died long ago, along with any way for the characters to escape. They're forced to research in an ancient library found in the cloud's ruins for instructions on how to build a sky ship with which to escape. Even then, they're on a cloud high in the sky and have no idea how to get home. The continental landscape below is completely unfamiliar (partly because in those days no surface dweller ever viewed the land from so far up, and partly because they may be thousands of miles away). Only when a friendly air trader sails by do they learn the full extent of aerial civilization.
- An ancient riddle, puzzle, or quest could lead the characters into the sky. Imagine a legend surrounding a powerful artifact that states it was recovered only when “Sir Varbegan the Brave left the city and walked to the sun as it fell behind the earth on the last day of the year.” This cryptic tale might in fact be perfectly straightforward: if you cast *air walk* and climb westward at sundown on the last day of the year, you will encounter Sellaine as it passes overhead. Set up a situation where the characters are forced to try something that seems crazy or even impossible, but fulfilling the dictate to the letter results in them encountering the cloud realms.
- Religious myths and legends can also send the players into the sky. Stories of the clouds housing gods are common. A holy text could cause a cleric to plan a trip to a cloud, seeking an artifact of his god that is rumored to lie there. Instead, he discovers Sellaine. (And maybe the artifact is still there, lost in Sellaine somewhere...)

Any of these options should get your characters into the sky without unduly influencing the surface world. Then it is entirely within your control at what point the surface world does learn of air travel, and what events occur from such a discovery.



## Air-based Campaigns

Air-based campaigns may seem completely different from land-based campaigns, but in fact they're quite similar. In this style of play, the PCs begin the game in the air. They could be crew members on a trading vessel, sailors in the sky elf navy, or freelance mercenaries looking to hire on with whoever will have them. Sky ships are familiar to them, a cloud city is the place they call home, and they certainly have no fear of heights.

Starting characters in the air immediately raises a very important question: What do they know of the surface world? You decide the answer to this question based on how you want to run your campaign. The answer has a huge impact on game play. If aerial characters are familiar with the surface world, there's regular contact between earth and sky. That means the world must be radically different from the standard fantasy realm. Just as air travel radically changed the modern world, it would radically change a medieval fantasy world.

The implications of regular surface-to-air contact are discussed in more detail below. Unless you're planning to flesh out an entirely new game world, we suggest that you start the PCs with little to no knowledge of the surface world. This changes the equation drastically. There is no contact between surface and sky, so there is no way the players could know anything about the surface. Thus, the surface realms – not the aerial realms – become the place of mystery. No one in the sky knows what's down there. Many laugh at the notion and simply dismiss the possibility. "Life on the surface? Be real!" Preconceived notions based on completely false reasoning could "explain" why life on the surface is impossible. "How would they breathe? All the air is up here!"

This is the opportunity for you to run the game in a completely new fashion. The aerial campaign can build up to an exploration of the surface realms, not the other way around. As the PCs grow in power, they are more capable of controlling their adventures and slowly (with your subtle urging) become more interested in exploring the surface world. Due to widespread false beliefs, no sky captain will risk sending his crew to the surface, but once the PCs can afford their own vessel, they can set out to re-establish contact with whatever still lives on the earth.

Now is the time to introduce some real mystery into the game by explaining what's on the surface world. First, you have to explain why airships cannot (or will not) venture to the earth in the current situation. Preconceived ideas or cultural taboos are handy mechanisms, but they lack the finesse and drama of more interesting stories. A good story of why travel is impossible could also tie into the nature of the mysterious surface world. Perhaps there are impassable winds constantly blowing upward from the earth. At high altitudes they dissipate and can be ridden by a skilled pilot, but at low altitudes it is simply impossible for any normal sky ship to push through them. The reason? After an eons-old war of aggression by renegade air elementals, the gods of the earth put the wind in place to protect their followers. If the PCs complete a quest they may gain an audience with avatars of these gods, and perhaps learn of a powerful artifact that would enable them to pass through the winds.

Another option is an impenetrable cloud cover. In this

situation, the aerial realms don't even have visibility to the surface world. If the cloud cover is thick enough, it's possible that the aerial denizens aren't even sure there is a surface world. No one's ever seen it and lived to tell about it, so why accept such myths as truth? In fact, the mile-thick cloud cover is the result of three huge volcanoes that erupted simultaneously many centuries ago. Ever since, sulfurous clouds have blocked out the sun. Life on the surface has become dark and desolate, and it is now a place where heroic adventurers would be welcomed. Nonetheless, characters who bring such tales back to their cloud city taverns will be met with disbelief and mockery. Only by providing some irrefutable fact will their stories ever be taken seriously. (The French fantasy adventure comic "The Mercenary," by V. Segrelles, is set in a world similar to this. It is good inspiration for aerial adventure ideas.)

It is also possible that the surface world isn't capable of reaching the air, even if its residents wanted to. The surface world might have no intelligent inhabitants. It could be like a vast nature preserve that the aerial realms use at their whim. It could be a prehistoric environment, where ferocious dinosaurs battle for prey as sky ships sail overhead. There may be intelligent creatures there, but they're stuck at a stone age level of technology. Even with the limited spirit magic that they possess, they simply can't build sky-worthy sailing vessels. Their technology may be more advanced and they may have mastered shipbuilding, but they simply lack the magical ability. A high-magic aerial realm existing over a low-magic surface world can make for a very interesting game.

Regardless of the details, the ultimate goal of an air-based campaign is to tie together the aerial and ground realms. As you move the players through various phases of adventure, keep this in mind. The early adventures of aerial campaigns are exploration, though this phase fades more quickly than in ground-based campaigns because it is assumed the characters are more familiar with the air realms. After exploration, move into conquest and combat missions, some diplomacy missions, and a few early trade missions. The trade contacts can eventually develop into the basis for a full campaign, especially if contact between earth and sky makes aerial trade a particularly lucrative profession. Establishing contact with the ground should remain a major long-term goal for some time, and when it is finally accomplished, it should be the segue to a new phase in the PCs' careers. Now that they are the mighty strangers who have alighted in magical airships to re-establish contact, they can begin to amass a kingdom of their own, both on land and in the clouds.

## Integrating Earth and Air

It's possible that careful players will run an extended aerial campaign without ever making the surface world aware of what floats overhead. If this does happen, you've got it easy. But most aerial campaigns eventually bring surface and air into contact. This can happen very early in the campaign if you're not careful about how you introduce sky ships. Even if you are careful, it often occurs later. If you don't engineer it, it's almost inevitable that the PCs will somehow make the introduction, either by crash-landing their sky ship or deciding to use its military advantages to



attack defended surface positions. An air vessel is the perfect way to get revenge against that evil baron whose impenetrable keep so frustrated the PCs earlier in their career – and as soon as they do that, the world will know the potential of sky ships.

Once the surface world learns of these flying wonders, certain changes will begin to take place. It may take many game years for them to be fully realized, but almost immediately, the world will change. Here are some of the changes and how to integrate them.

At first, sky ships will be a curiosity and novelty. A few may be purchased from the sky elves or other aerial traders, but there aren't many of them. Surface mages work studiously to learn how this magic works.

Within six months to a year, surface mages have learned the basics of sky ship construction. Part of this time includes the search for obscure materials and special components, many of which are available only in the cloud realms or on the elemental plane of air.

It takes another six months to a year for the first functioning sky ships to be built. There are many early attempts, most of which fail. A few of the more simple designs (basic scooters and skiffs) are completed without problem, but builders of larger models encounters a number of difficulties. Those who simply retrofit sailing vessels with sky ship engines are able to build the first "flying boats," but their success is short-lived; such jury-rigged devices degrade quickly under the stresses of aerial flight. It takes many repeated attempts before the first real successes occur.

Within the next one to two years, sky ships start appearing everywhere. Every count, duke, baron, or knight of any standing commissions one or more, while kings, emperors, and other fabulously wealthy individuals commission entire fleets. Merchant houses, powerful churches, and even individual adventurers also build their own ships.

Once sky ships become common, the world rapidly becomes substantially smaller. Across the board, traveling time is cut by a half or more. Distant points once far outside the range of normal overland travel are within reach. Impassable terrain features like gorges, rivers, mountains, and deserts are nothing more than inconveniences to an air ship.

This has huge implications. First, prices on many commodities drop. Goods transported over short distances, like a day or two by land, aren't affected. It costs almost as much to build and maintain a sky ship over those distances as you realize in cost savings. But goods transported longer distances are now much cheaper to move. Instead of 40 oxen, it now takes one sky ship. Metals in particular are much cheaper to transport; industry no longer needs to be located directly beside mines. Wool, cotton, tobacco, wheat, and other basic supplies see their prices drop along with transportation costs. Competition for the middleman role increases as new sky ship owners start making freelance deliveries. Existing trade guilds find their roles challenged, especially if the old-time traders don't adapt rapidly enough. Kings whose fortunes depended on controlling the natural resources in their kingdoms find they suddenly have competition from distant principalities that used to be too far away to meet with suppliers.

Second, there are new conflicts. Where it used to take a long time to get an army from point A to B, giving the defender more than enough time to prepare as long as his

scouts were doing their jobs, it now takes hardly any time at all. With a few sky ships and a dusk takeoff, a king can literally put an army into a neighboring kingdom by sunrise. Longtime hatreds and rivalries suddenly flare up as bickering parties have a new way to settle their score. Even those without an agenda find new ways to fight. Raiders and pirates such as orc brigands now have a quick and easy way to invade, loot, and retreat before they're caught.

Third, the very nature of war changes. Initially, sky ships are used strictly for transportation. This may go on for several months, or even years, until a particularly insightful general somewhere realizes their true potential. He fills one sky ship with archers and uses it as a mobile fighting platform in the battle itself rather than simply as a transport vehicle. Or he uses a sky ship to drop boiling oil and rocks on soldiers below who can't reach the ship. Perhaps he even deploys his entire army in the sky ship and simply pelts the soldiers below until they've been routed. One way or another, this easy victory gives ideas to other generals, and pretty soon the nature of warfare is altered. New kinds of sky ships are developed for specific military purposes. There are dog-fighters, built for taking out enemy weapons platforms. There are bombers, meant for decimating closed ranks of knights. There are castle-bashers loaded with catapults. No army rides to battle without aerial support.

This brings the forth major change: massive destabilization. Those who master the use of the new sky-weapons early on use them to launch invasions. This is nothing like the small-time disputes of the second phase of change. These are massive wars involving multiple kingdoms on an unprecedented scale. Who is the Genghis Khan, Attila the Hun, Alexander the Great, or Napoleon of your world? Whoever has the ambition, guts, and vision to imagine himself emperor of the world now has the means to make it possible. Alliances shift, borders change, and suddenly there's a new warlord whose mobile, fast-moving sky ships can threaten kingdoms far outside his earlier range. Remember that the aerial realms themselves might seem to a surface warlord like new grounds for conquest. Cloud cities could be invaded by a surface-world duke who claims that anything in his kingdom's airspace belongs to him.

The fifth major change is the appearance of the exotic. Thanks to the lowering costs of transportation, strange things from foreign lands now make their way into your society on a regular basis. This starts with objects of art, craftwork, and exotic new weapons. Soon there are new foods and animals. With those foods and animals come strange new immigrants, and then come the germs. Diseases jump hundreds of miles in a single day, reaching populations that have no immunities to them. At least one major plague grips the world. Thousands die in the streets.

As you can see, the implications of surface-to-air contact are huge. Widespread use of sky ships fundamentally alters the way a medieval fantasy world works, creating a period of change, upheaval, and turmoil. Can your world handle it? That's something to consider when deciding how to integrate sky ships into your campaign. Managing the flow of change provides for a great overarching metaplot, perhaps even involving the characters as they try to ambush the evil duke's attempts to build sky ships for war.

What if you don't want all this change to your world? You have three options. The first is to limit the power of sky ships at low altitudes. Maybe sky ships are powered with ele-

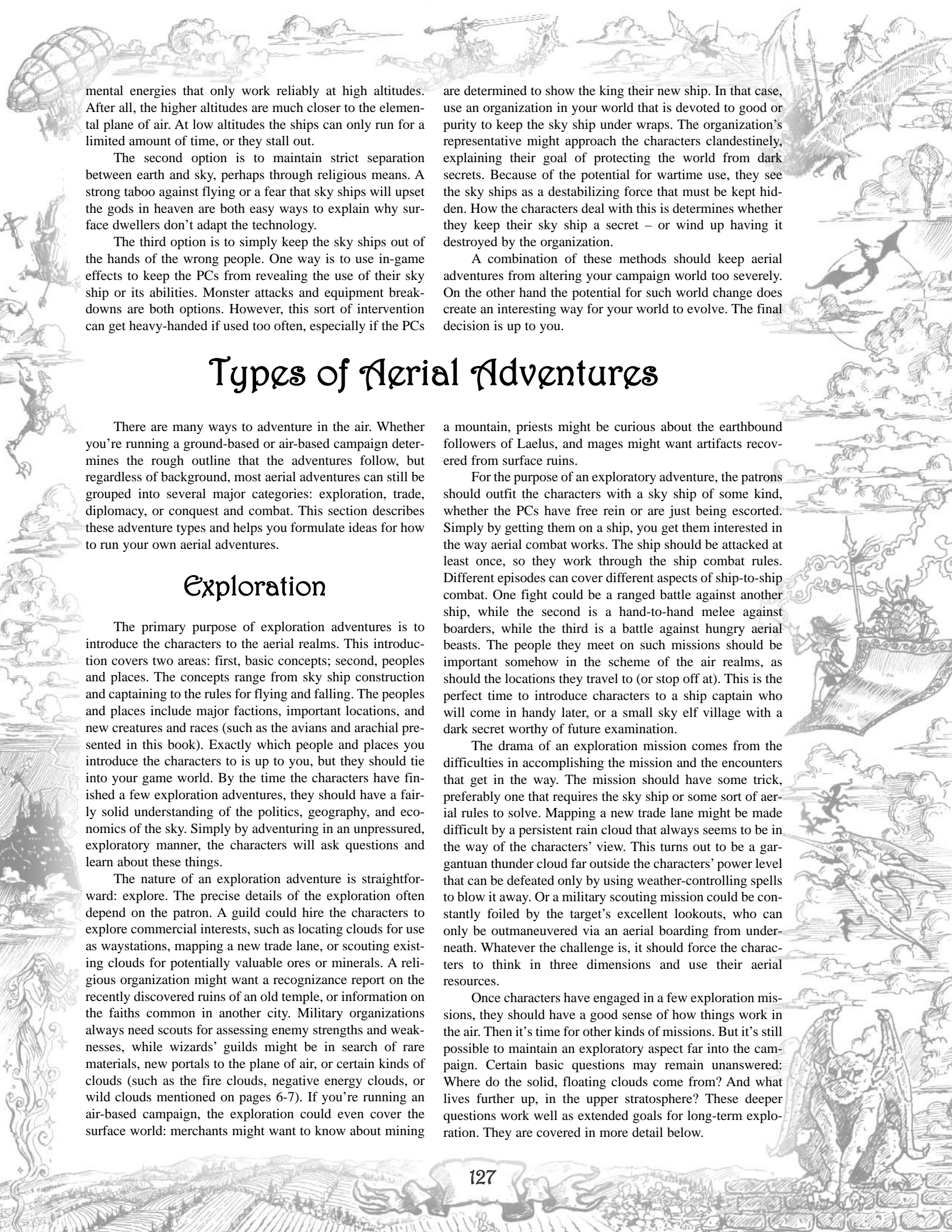

mental energies that only work reliably at high altitudes. After all, the higher altitudes are much closer to the elemental plane of air. At low altitudes the ships can only run for a limited amount of time, or they stall out.

The second option is to maintain strict separation between earth and sky, perhaps through religious means. A strong taboo against flying or a fear that sky ships will upset the gods in heaven are both easy ways to explain why surface dwellers don't adapt the technology.

The third option is to simply keep the sky ships out of the hands of the wrong people. One way is to use in-game effects to keep the PCs from revealing the use of their sky ship or its abilities. Monster attacks and equipment breakdowns are both options. However, this sort of intervention can get heavy-handed if used too often, especially if the PCs

are determined to show the king their new ship. In that case, use an organization in your world that is devoted to good or purity to keep the sky ship under wraps. The organization's representative might approach the characters clandestinely, explaining their goal of protecting the world from dark secrets. Because of the potential for wartime use, they see the sky ships as a destabilizing force that must be kept hidden. How the characters deal with this determines whether they keep their sky ship a secret – or wind up having it destroyed by the organization.

A combination of these methods should keep aerial adventures from altering your campaign world too severely. On the other hand the potential for such world change does create an interesting way for your world to evolve. The final decision is up to you.

## Types of Aerial Adventures

There are many ways to adventure in the air. Whether you're running a ground-based or air-based campaign determines the rough outline that the adventures follow, but regardless of background, most aerial adventures can still be grouped into several major categories: exploration, trade, diplomacy, or conquest and combat. This section describes these adventure types and helps you formulate ideas for how to run your own aerial adventures.

### Exploration

The primary purpose of exploration adventures is to introduce the characters to the aerial realms. This introduction covers two areas: first, basic concepts; second, peoples and places. The concepts range from sky ship construction and captaining to the rules for flying and falling. The peoples and places include major factions, important locations, and new creatures and races (such as the avians and arachial presented in this book). Exactly which people and places you introduce the characters to is up to you, but they should tie into your game world. By the time the characters have finished a few exploration adventures, they should have a fairly solid understanding of the politics, geography, and economics of the sky. Simply by adventuring in an unpressured, exploratory manner, the characters will ask questions and learn about these things.

The nature of an exploration adventure is straightforward: explore. The precise details of the exploration often depend on the patron. A guild could hire the characters to explore commercial interests, such as locating clouds for use as waystations, mapping a new trade lane, or scouting existing clouds for potentially valuable ores or minerals. A religious organization might want a recognizance report on the recently discovered ruins of an old temple, or information on the faiths common in another city. Military organizations always need scouts for assessing enemy strengths and weaknesses, while wizards' guilds might be in search of rare materials, new portals to the plane of air, or certain kinds of clouds (such as the fire clouds, negative energy clouds, or wild clouds mentioned on pages 6-7). If you're running an air-based campaign, the exploration could even cover the surface world: merchants might want to know about mining

a mountain, priests might be curious about the earthbound followers of Laelus, and mages might want artifacts recovered from surface ruins.

For the purpose of an exploratory adventure, the patrons should outfit the characters with a sky ship of some kind, whether the PCs have free rein or are just being escorted. Simply by getting them on a ship, you get them interested in the way aerial combat works. The ship should be attacked at least once, so they work through the ship combat rules. Different episodes can cover different aspects of ship-to-ship combat. One fight could be a ranged battle against another ship, while the second is a hand-to-hand melee against boarders, while the third is a battle against hungry aerial beasts. The people they meet on such missions should be important somehow in the scheme of the air realms, as should the locations they travel to (or stop off at). This is the perfect time to introduce characters to a ship captain who will come in handy later, or a small sky elf village with a dark secret worthy of future examination.

The drama of an exploration mission comes from the difficulties in accomplishing the mission and the encounters that get in the way. The mission should have some trick, preferably one that requires the sky ship or some sort of aerial rules to solve. Mapping a new trade lane might be made difficult by a persistent rain cloud that always seems to be in the way of the characters' view. This turns out to be a gargantuan thunder cloud far outside the characters' power level that can be defeated only by using weather-controlling spells to blow it away. Or a military scouting mission could be constantly foiled by the target's excellent lookouts, who can only be outmaneuvered via an aerial boarding from underneath. Whatever the challenge is, it should force the characters to think in three dimensions and use their aerial resources.

Once characters have engaged in a few exploration missions, they should have a good sense of how things work in the air. Then it's time for other kinds of missions. But it's still possible to maintain an exploratory aspect far into the campaign. Certain basic questions may remain unanswered: Where do the solid, floating clouds come from? And what lives further up, in the upper stratosphere? These deeper questions work well as extended goals for long-term exploration. They are covered in more detail below.



# Trade

It doesn't take a genius to realize that sky ships make trading a lot more profitable. Not only do they reduce transportation costs and times, they also vastly increase the potential market for any given manufacturer. A produce farmer can only sell to customers who can receive the vegetables before they spoil. With horses and wagons, the potential market extends perhaps 50 or 100 miles in every direction. But with sky ships capable of traveling hundreds of miles a day, the potential market size grows to as much as 500 miles in every direction.

The characters may seek to use their sky ships for trading missions, whether for their own profit or in the employment of others. Trading missions directed by outside patrons may be very specific. Retrieving a certain kind of rare fruit, delivering a late shipment on a tight deadline, or guarding a valuable cargo are common examples.

Trading missions initiated by the characters can start with much more amorphous goals. They may encounter a village that has a noticeable shortage of workable metal. Since the nearby mine was played out last year and the next-closest mine got taken over by orcs, shipments of metal have been expensive and unreliable. The blacksmith now spends his days idling in the shade for lack of any materials to work with. An adventure or two later, the characters might come across a town with a surplus of metal. Perhaps the residents just discovered a new mine. If the players put two and two together, they'll see the opportunity for a profit.

## Trading Rules

When it comes to trading in bulk quantities, use the trade goods table to determine the size and value of cargo. Most of the entries are self-explanatory. This list includes goods that are generally traded in large quantities. Common items, such as wagon wheels and rope, are not included because they can generally be provided by local merchants almost anywhere.

The prices shown are bulk prices, which are lower than the normal list prices. As described below, the characters buy at somewhere near this price, then sell at a (hopefully) higher price. They make their sales in bulk to local wholesalers and resellers (not the end users), who in turn charge their own markup when they sell to local dealers. For example, a ton of staple foods would cost the characters much more than 50 gp if they bought it meal-by-meal at the village marketplace. But buying a ton of flour, wheat, or corn at once is a lot cheaper, so they pay only the bulk price.

The size of a particular town or city determines how much of each good is in demand there. Use your judgment on this; a hamlet of 27 residents obviously doesn't need three tons of common spices. For reference, consult the d20 rules concerning available cash for a community based on its size and GP limit (see Chapter 5: Campaigns in the DMG, under World-Building: Generating Towns).

The goal of trading is obviously to make a profit. The extent of a profit made is determined by two skills: Diplomacy and Profession (trader). Diplomacy determines a trader's skill at negotiation, including everything from being charming to knowing who to trust and when to say the right thing. Profession (trader) covers a different set of abilities, including knowledge of the market and its players, when and where are the best times to buy, and an innate sense of supply and demand. A character with 5 or more ranks of Diplomacy receives a +2 synergy bonus to Profession (trader).

The trading character makes his check (his choice of which skill) against the opposed Profession (trader) or Diplomacy check of his trading partner. For example, a character looking to buy exotic cloth would locate a seller, then make the opposed skill check against him. The result determines how well the negotiations go. If the character wins the check, he can purchase the goods for a discount off the listed price of 1% for every point by which he beat the

## Trade Goods Table

Trade Good	Unit	Unit Cost	Trader Level
Alcohol	Ton	1,000 gp	4
Armor, heavy	Ton	8,000 gp	6
Armor, light	Ton	1,000 gp	4
Armor, medium	Ton	3,000 gp	4
Beverages	Ton	750 gp	4
Cloth, common	Ton	700 gp	4
Cloth, exotic	Pound	250 gp	8
Cloth, rare	Ton	1,000 gp	6
Construction materials	Ton	1,000 gp	4
Gems, precious	Pound	10,000 gp	10
Gems, ornamental	Pound	2,000 gp	6
Gems, semi-precious	Pound	5,000 gp	8
Magic items	By item	By item	10
Meats, exotic	Pound	200 gp	8
Meats, rare	Ton	700 gp	6
Meats, mundane	Ton	100 gp	4
Metals, common	Ton	1,000 gp	4
Metals, precious	Pound	75 gp	10
Metals, refined	Ton	3,000 gp	6
Scribing materials	Ton	1,000 gp	6
Spell components	Pound	100 gp	10
Spices, common	Ton	500 gp	6
Spices, exotic	Pound	1,000 gp	10
Staple foods	Ton	50 gp	4
Weapons, exotic	By item	By item	8
Weapons, martial	Ton	5,000 gp	6
Weapons, simple	Ton	2,500 gp	4



other trader. For example, a check result of 25 against the other trader's result of 21 means the character can buy the good for 4% off the listed price. If the character fails the check, he suffers the same situation in reverse: he must pay 1% more for every point by which he failed. If he can locate another seller, he can try to negotiate a better deal there.

When the character arrives at the place where he will sell the goods, he makes the same check against the buyer. For every point by which the character beats the other trader, he can charge 1% more than the listed price. For every point by which the character is beat by the other trader, he is offered 1% less of the listed price.

Regardless of the dice rolls, no price can be adjusted by more than 20% in either direction. A character is always free to refuse a sale if he doesn't like it, but he can only retry his check when some aspect of the situation changes, or at least a month has passed. Obviously a profit is not always guaranteed, but a good trader should get one most of the time.

NPC traders are usually experts who specialize in trading. When characters sell off small quantities of trade goods to end users – such as the blacksmith in the village example above – use the stats for that particular buyer. Locating end users such as this takes much longer than simply showing up with a load of cargo for the wholesalers. Wholesalers are always professional traders. The more valuable the goods being traded, the more experienced the trader, as shown in the “trader level” column of the trade goods table. This is the minimum expert level of someone who trades in these goods. Full stat blocks for NPC traders are presented on page 116. Since these traders will almost always be better negotiators than the PCs, the PCs may find themselves on the losing end of many deals. They may wish to employ professional traders, which is perfectly acceptable. Such professionals generally charge 3 sp per day per level, plus a 1% royalty per character level of the profit on the deals they arrange. For example, a 10th level trader would charge 30 sp (3 gp) a day and ask for a 10% royalty.

Situational modifiers apply to the trades. Supply and demand are the biggest factors. The GM should apply modifiers based on how desperately the NPC wants to buy or sell. Remember that big-picture supply and demand situations modify the attitude of every trader in a town, not just a single individual. Generally these modifiers start at +2 (for moderate interest) and extend all the way up to +10 (for regions in desperate need of a vital good). For example, a character bringing metal to the aforementioned village may receive a +6 modifier to his check because the villagers need the metal so badly. If he waits another month and no one else has supplied the village, the modifier could rise to +7 as more and more metal supplies are needed. On the other hand, if another trader fills the void while the character is waiting, the modifier might drop to +0 before the character's sale goes through. Note that this modifier does not apply to the check to buy the goods, because the initial seller has no involvement with the village. It's only the desperate buyer (the village) that incurs this modifier. These rules are not meant to encourage hoarding of food or other such selfish acts, and don't account for price spikes due to famine or other extreme situations.

Other situational modifiers can be arranged, and may make for interesting adventure hooks. The promise of profit from a high Diplomacy score may motivate the characters to pursue new magic items that raise Charisma. Or they might

do favors for trading partners in order to get a better deal. In the example above, if the characters were to rid the town of some sort of marauding menace before they begin their negotiations, they should receive a +2 modifier due to earned goodwill. Of course, if they charge a king's ransom for their services, that modifier could become negative. Finally, gift-giving always helps. Giving a gift up to 5% of the trade's base value grants a +1 bonus, and giving a more valuable gift grants a +2 bonus to this trade *and* the next.

Haggling takes time. Cultures have rituals for these negotiations, ranging from tea or coffee to festivals, extended meals, and social events. At the very least, every transaction should take four hours of game time to resolve, and possibly much longer for high-profile or expensive trades.

## Adventures in Trading

So now that you've got a solid framework for the rules of trade missions, how do you turn them into exciting adventures? Finding, transporting, and protecting shipments of goods are adventures in themselves. Characters may learn of a chance for great profit if they can only find the right goods. For example, a town traditionally uses the spice cardamom in its annual spring festival, but a drought has wasted its supply. Failure to complete the festival rituals properly is a terrible omen, and the village elders are desperate for cardamom at any price. If only the characters knew where to get some, and quickly...

Protecting a shipment is another adventure in itself. Once the local pirates know the characters tend to carry valuables, there will be regular conflicts. There might even be one particular pirate gang that harries the characters constantly, or simply lurks at a distance and stalks them, refraining from attacking until the characters are worn down by monsters and natural hazards.

The act of transporting goods is valuable in itself because of the value of trade routes. Powerful merchant companies often pay explorers to find the cheapest, most profitable routes between two major trading centers. On the land, these routes avoid terrain features as well as dangerous monsters. In the air, they follow favorable weather patterns, and may vary in altitude, direction, and time of travel. The best trade routes are carefully guarded secrets, especially because those who know about them make a lot of money on them by getting goods moved faster and cheaper than rivals. Characters may be forced to fight rival merchants for the best trade routes, or may face situations where there is no easy way to get goods to a particular location. The village in need of cardamom, for example, may be on an irregularly floating cloud whose location can't be predicted very well. Or it might be stable and predictable, but on the other side of a no-man's-land known to be populated by flying brigands.

Characters may also encounter the trade hook in reverse: they could end up with a huge load of goods but no one to buy it. What if they defeat a wandering pirate vessel only to find its holds filled to the brim with canned sardines? Sardines may seem normal to you and me, but the lack of oceans in the sky means they count as rare meat there. Once the characters realize they have 10 tons of goods worth 700 gp a ton, they'll get real interested in selling sardines. But how do they sell the goods without attracting suspicion that they might be pirates? And where do you unload 20,000 pounds of sardines?



A final hook for trade adventures is a trade war. Once the characters start trading, they may inadvertently (or intentionally) move in on the turf of an existing trader. If the rival is a powerful guildsman or noble, he may have substantial resources to draw upon in order to keep the characters out. These situations rarely turn into open battle, but blood can be drawn, and sabotage and misinformation campaigns are common. The trade war presents the opportunity for a very realistic conflict over trading rights. Selling at the right price might not be enough to get the sale; it might be more important to pay the local dragon to eat your competitors...

## Diplomacy

Diplomacy missions are difficult to run, but they offer a respite from the combat emphasis of most campaigns. A session or two of diplomacy changes the players' attitudes and offers them a new kind of challenge.

A diplomacy mission starts with the basic premise that social interaction can be as complicated and intertwined as combat. It then proceeds to a social situation that demands careful resolution through non-combat means. A correct resolution produces benefits for all sides, while a failure has great costs.

Diplomacy missions may not seem appropriate to aerial campaigns, but in a sense they are perfect. The mobility granted by a fast-moving airship allows for negotiations to take place very quickly. If the characters are in possession of such a ship and in good standing among their community, it makes them the perfect option for certain diplomatic missions, either as the primary envoys or as assistants (or even spies). In addition, the very nature of most aerial campaigns guarantees that there will come a time of new interaction between the surface world and its aerial neighbors. When this contact begins, the PCs may be the only people in their homeland to have extensive experience with this new realm. They'll make the perfect diplomats.

Adventure hooks for diplomacy scenarios vary greatly. Usually they involve the needs of an entire country, or at least a major faction in that country. Their goal is to manage relations between countries, hopefully solving problems in the process. Specific scenarios for an aerial campaign could start with a straightforward establishment of diplomatic ties. When a powerful new force appears – and a ship full of sky elf warriors landing in the king's courtyard definitely qualifies – the existing powers-that-be always have three thoughts: (1) Are they a threat? (2) How powerful are they? (3) How can I turn this to my advantage? When the characters get involved, they are commissioned by their king to travel to the aerial realms (or surface lands, if they start in the air), where they must meet the representatives of the foreign government, exchange information, learn about their needs, assess their intentions and trustworthiness, and find avenues for mutual benefit.

That's the first step, and that's worthy of an adventure in itself. Are the characters supposed to keep their hands clean, or can they spy? Does the king want information that can be used to blackmail the enemy ruler? Are the characters allowed to use bribes, misinformation, or even threats of violence to uncover state secrets? Is part of their mission to scope out the political landscape so their king knows how easy it might be to destabilize his aerial counterpart?

At the same time all this is going on, the characters must consider their hosts' own intentions. Why did they allow the characters to visit as envoys? Do they truly have good intentions? Are they judging the characters' loyalty in the hopes of acquiring double agents? Are the characters receiving a true picture of things, or are they being fed mis-

information? Are they being spied upon even as they try to spy upon their enemies?

As you can see, a simple diplomatic mission can immediately introduce all sorts of hooks. If you decide to continue the campaign with a diplomatic element, you can add even more complex missions. When the aerial king hears that the surface-world king is now building his own fleet of airships, he may feel a challenge to his power. After all, his realm has always been immune to attack from the surface world, but it won't be after the surface world is equipped with airships. He sends a delegation that asks the surface king to stop his airship production. In exchange, he offers an alliance, use of some of his own airships, and financing (essentially a bribe) to fund armies to destroy any airships built by neighboring countries. It may seem as if he's offering a virtual monopoly on air power to his one ally – which, in a sense, he is. But, unbeknownst to the characters (unless they have informants in high places), the aerial king has secretly offered this same arrangement to all three of the surface kingdoms that are building airships, and once their fleets are destroyed he plans to invade!

Running a diplomacy adventure is a challenge. You should construct a flowchart to help keep track of the character choices and where they lead. Think of the flowchart as a "virtual dungeon" that structures the course of the adventure. The different "rooms," or encounters, are primarily social.

The first encounter is the introduction of the envoys to the aerial king. This offers the chance for Spot checks around the king's quarters, looking for the little details that can give away a lot of information, as well as Bluff or Sense Motive checks. Clever characters may even say unusual things to test the king's responses, relying on specific Sense Motive or Diplomacy checks to evaluate what he says.

The next encounter may be a series of brief meetings and introductions with the major players in the air realm. Then there comes a state dinner, where the characters get to observe interactions between various factions. They're basically let free in a large mansion... what do they do? This is the chance to sneak around, or to win trust, or to find informants and allies.

After that come encounters created by the characters' own actions (the secret meeting to pay off the informant, or their moonlit jaunt through the courtyard to spy on someone), and those that are part of the "official state visit." The aerial king will want to show off his kingdom, so he'll take the characters to the best things his realm has to offer: museums, temples, monuments, and, of course, his most fabulous airships. At each such encounter, the characters will get the chance to make more decisions about how to proceed.

Although diplomacy missions involve very little combat (at least, if they go well!), they feature a lot of skill checks. You can structure the skill checks to make each encounter longer than a simple contested roll. There can be



initial Diplomacy or Bluff checks upon introduction, then subsequent checks whenever some major new aspect of conversation comes up. Each topic of conversation might have different conclusions or “treasure” (in this case, what the characters learn) based on a new check. There may be a specific moment where a Sense Motive check reveals the interlocutor feels weak on a particular subject, and an Intimidate attempt at that moment can produce greater concessions – but an Intimidate attempt at the wrong moment can produce only hostility.

In diplomacy missions you can reward XP based on achieving specific goals rather than winning combats. The characters may have some specific goals ahead of time (“find out how many soldiers are in their army”) as well as overarching metagoals (“keep the king’s reputation intact” or “maintain the balance of power with the neighboring kingdom”). At the same time, certain opportunities may present themselves on the mission. If the characters manage to bribe the aerial king’s main advisor in order to uncover state secrets, they should receive an XP bonus – but not if he’s actually consenting to a bribe solely so he can report the treachery to his king, who will then evict the double-crossing surface-world envoys!

The contact between earth and air presents a great opportunity for diplomacy. In most campaigns it’s rare for an entirely new kingdom to be discovered; major powers don’t simply appear out of nowhere. Aerial adventures change that. Diplomacy missions are a great change of pace for your game and they’re suited perfectly to the changes that can occur over the course of several aerial adventures.

## Conquest and Combat

Ah, combat – the meat and blood of every d20 adventure! Basic conquest-and-combat missions are always fun. The new frontiers of aerial realms may tempt characters to carve out their own kingdom, searching for a cloud where they can build a stronghold. At the same time, there are new monsters to fight, new enemies to be defeated, and new strategies to use. Three-dimensional aerial combat is completely different from ground combat, after all.

Conquest-and-combat missions satisfy the basic instincts of every d20 adventurer, while also presenting some new challenges. The old “save the town from the orcs” scenario takes on a whole new meaning when the orcs ride giant bats and even the lowest-level orc can kill you with a single bull rush that knocks you over the ship’s railing.

For aerial adventures with a back-to-basics combat feel, there are a few options. The first is aerial combat between creatures or constructs capable of flight, such as dragon versus sky ships, sky ships versus orc bat-riders, or sky ship versus sky ship. The second is battles on the sky ships themselves, such as when pirates board in search of loot, or arachial board in search of slaves or food. A final option is battles within cloud cities, floating castles, and other air-borne locations.

The adventure hooks can vary, but they’re usually similar to the hooks used in earthborne adventures. A town may need protection from marauding monsters. A pirate vessel has been preying upon the trade lanes. A dragon is demanding a sacrifice or it will ransack the town. A sky ship has gone missing. An old legend tells of a ruined cloud city that

floats past Sellaine once every 527 years. And so on.

Use the basic ideas that fuel all fantasy adventures, then adapt them to the sky. Be sure to think about the motivations of the creatures and people of the sky, and how they can be used as adventure hooks. Consider the histories of individual cloud cities, sky ships, and even ship captains and crews. Finally, think of ways that seafaring adventures can be adapted to the sky. Buried treasure, lost maps, and ghost ships are all just as feasible in the sky as on the sea.

Use small details and “the little things” to make the plot hook really fit the sky. Remember that aerial societies depend heavily on aerial transportation for their survival. The nature of that transportation and their relationship to it defines their culture in a large way. One small settlement might build strange, oblong sky ships almost like floating wooden whales, while another may attach such great importance to the pegasus herds that guided them to safety many years ago that they build massive, symbolic pegasus wings onto every sky ship. Adventures can be linked to these eccentricities. The society of whale ships might be suffering unwarranted attacks from pirates who are convinced their ships’ extra cargo capacity must be holding valuables, while the other society might be willing to pay a king’s ransom for the head of whoever has been poaching the pegasus herds.

Whatever the adventure hook, be sure to sprinkle a good mix of combat missions in every campaign. And as the characters advance in level and set their sights on kingdoms of their own, these combat missions may become conquest-oriented, which is fine. Let the air realm become their realm!



# Traveling In the Skies

The sky ship is the standard mode of transportation throughout the skies, and this book generally assumes that's how characters will go from one cloud city to the next. But there are a lot of other options. Magic items, natural flying ability, and airborne mounts are the most common, with teleportation or gates providing another option. This section discusses the ways characters can travel, and how to handle those modes of transportation in various campaigns.

## Sky Ships

Sky ships are easily obtained in any large cloud city. Most standard models are available for sale from ship-builders with delivery within a few weeks of the purchase, and there are always a few "used" models available for the right price. Customized ships built to unusual specifications can also be obtained, but they take several months to build.

As a general rule, sky ships provide the easiest way to manage an aerial campaign. They have cargo capacity, they don't require constant feeding, they're easily available, and they're hard to attack with *dispel magic* effects (at least, compared to the personal scale of rings and magic items). Full details on a wide variety of sky ships can be found on pages 48-53, and deck plans are on pages 136-143.

On the other hand, sky ships have the potential to unbalance a campaign world, particularly if introduced into widespread ground use. Be careful about how you integrate them, as described above.

## Flying Mounts

Flying mounts are more exotic than sky ships. It's easy for an aerial campaign to feel remarkably similar to a naval campaign if ships are overemphasized. Using flying mounts draws a firm distinction between the sea and sky. Mounts can also make the PCs a more distinctive bunch of adventurers –

how many locals can claim to ride pegasi into battle? Intelligent mounts can even add adventure hooks, presenting their own needs, histories, mysteries, and opinions. A mount may wish to find what happened to a previous rider, want to pursue vengeance against a natural predator that ate its eggs many years ago, or have a natural fondness for small children that leads it to constantly offer them free rides, resulting in unanticipated hijinks.

The core d20 rules present a wide variety of potential flying mounts, and this volume introduces more. Common flying mounts can be found for sale in major metropolitan areas in the sky realms, while the uncommon varieties must be sought out – a good hook for adventure, whether it's the PCs who want the exotic mount or their patron.

The table below summarizes the most common aerial mounts. Domesticated varieties of common mounts can be found for sale in most aerial cities, uncommon mounts may occasionally be sold in a trained condition (and if so, usually at inflated prices), and rare mounts can only be found wild in their native habitat. Most flying mounts require an exotic saddle.

The table does not include creatures that can fly but which are not commonly used as mounts. This includes demons, devils, and nightmares, which only serve as mounts when ordered to by superiors or when bound into service, as well as air elementals and genies, which can only be used as mounts by casting summoning spells or being drawn to the leadership skills of unusually charismatic characters. Nor does this table include dragons, since they are never found for sale. Even if the characters were to obtain a dragon's eggs, that wouldn't be enough to ensure a mount; dragons are intelligent and strong-willed, and offer rides only to those whom they respect.

Characters who wish to ride exotic mounts such as dragons, demons, devils, elementals, or other creatures must persuade the creatures to serve as their mount (either through combat, Diplomacy, or Handle Animal). Even then they must train the creatures (no easy task) and may need to have the same alignment as their mount to prevent future conflicts.

### Flying Mounts

Mount	Speed (Maneuver)	Rarity	Load (Light/Medium/Heavy)	CR	Cost (Egg/Young)
Arrowhawk, elder	60 ft. (perfect)	Rare	300/600/900	8	2,000/3,000
Chimera	50 ft. (poor)	Rare	348/699/1,050	7	4,500/8,000
Dire hawk	60 ft. (average)	Common	300/600/900	3	1,500/2,000
Dragonne	30 ft. (poor)	Uncommon	348/699/1,050	7	4,500/8,000
Eagle, giant	80 ft. (average)	Uncommon	300/600/900	3	2,500/4,000
Griffon	80 ft. (average)	Common	300/600/900	4	3,500/7,000
Hippogriff	100 ft. (average)	Common	300/600/900	2	2,000/3,000
Manticore	50 ft. (clumsy)	Rare	500/1,000/1,500	5	4,500/8,500
Noctilius bat	40 ft. (perfect)	Rare	300/600/900	4	3,000/4,500
Owl, giant	70 ft. (average)	Uncommon	300/600/900	3	2,500/4,000
Pegasus	120 ft. (average)	Uncommon	300/600/900	3	2,000/3,000
Roc	80 ft. (average)	Rare	4,000/8,000/12,000	9	6,000/14,000
Spider eater	60 ft. (good)	Uncommon	306/612/920	5	2,000/3,000
Wyvern	60 ft. (poor)	Rare	500/1,000/1,500	6	5,000/11,000

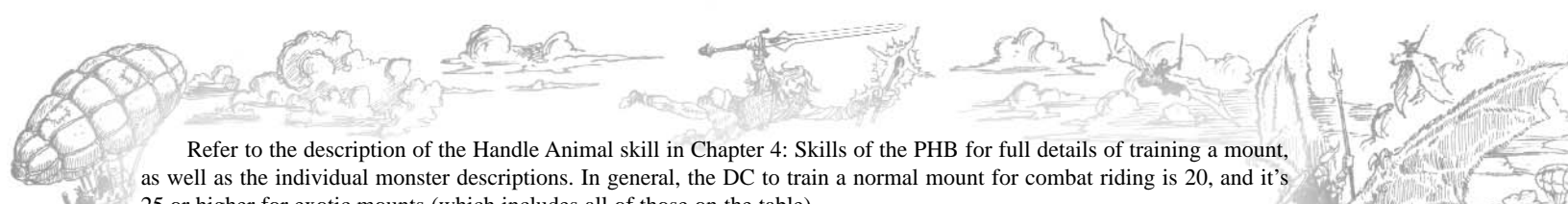

Refer to the description of the Handle Animal skill in Chapter 4: Skills of the PHB for full details of training a mount, as well as the individual monster descriptions. In general, the DC to train a normal mount for combat riding is 20, and it's 25 or higher for exotic mounts (which includes all of those on the table).

## Personal Magic Items

Only the most powerful archmages rely strictly on personal magic items for their aerial transportation. Everyone else considers it too risky. What if you inadvertently enter a natural dead magic zone? What if an enemy targets you with *dispel magic*? What if you run out of charges? There is far more safety on the deck of a ship.

Nonetheless, some powerful casters do rely solely on magic items for transportation. *Wings of flying* are quite popular in the aerial realms. It's easy to find them for sale in most major ports, along with other popular magic items like *potions of feather fall* and *fly*. Magic is common among the aerial realms, and many a mage has found that selling potions to sky sailors is a reliable way to make a living.

Here is a list of some of the most common personal magic items, along with their costs. Refer to their individual descriptions in Chapter 7: Magic Items of the DMG for full details. Every major port has at least one wizard who sells some or all of the more basic items below on a regular basis, and can make most of those that aren't immediately available (at least those within his caster level range).

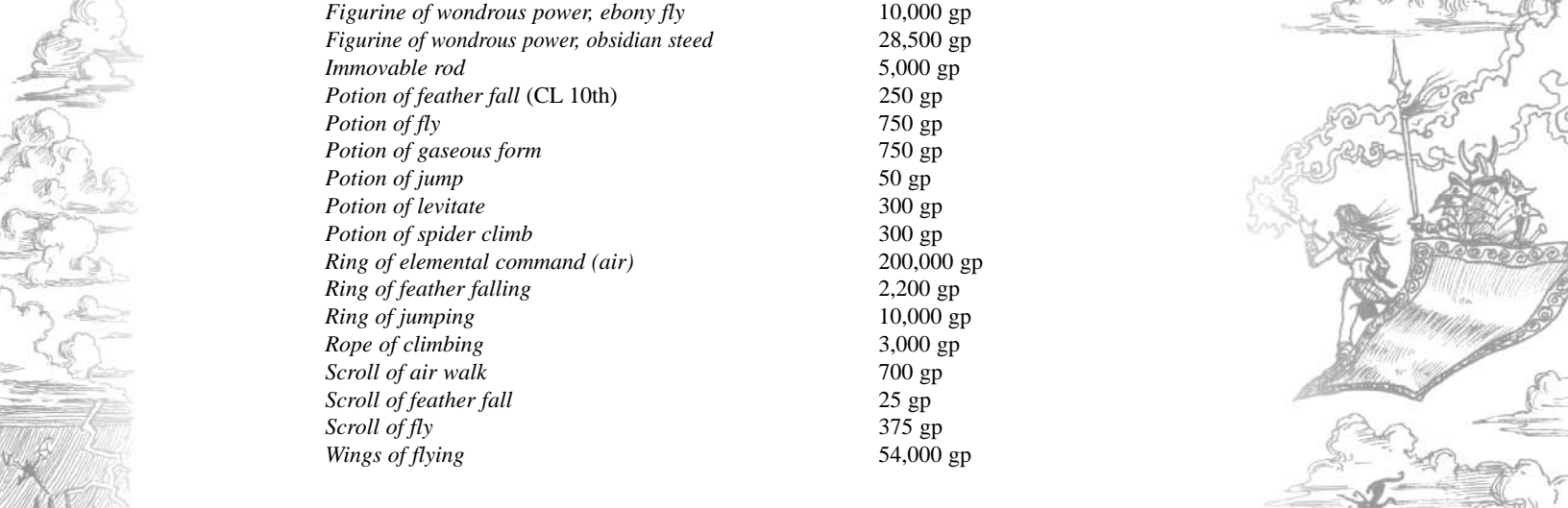
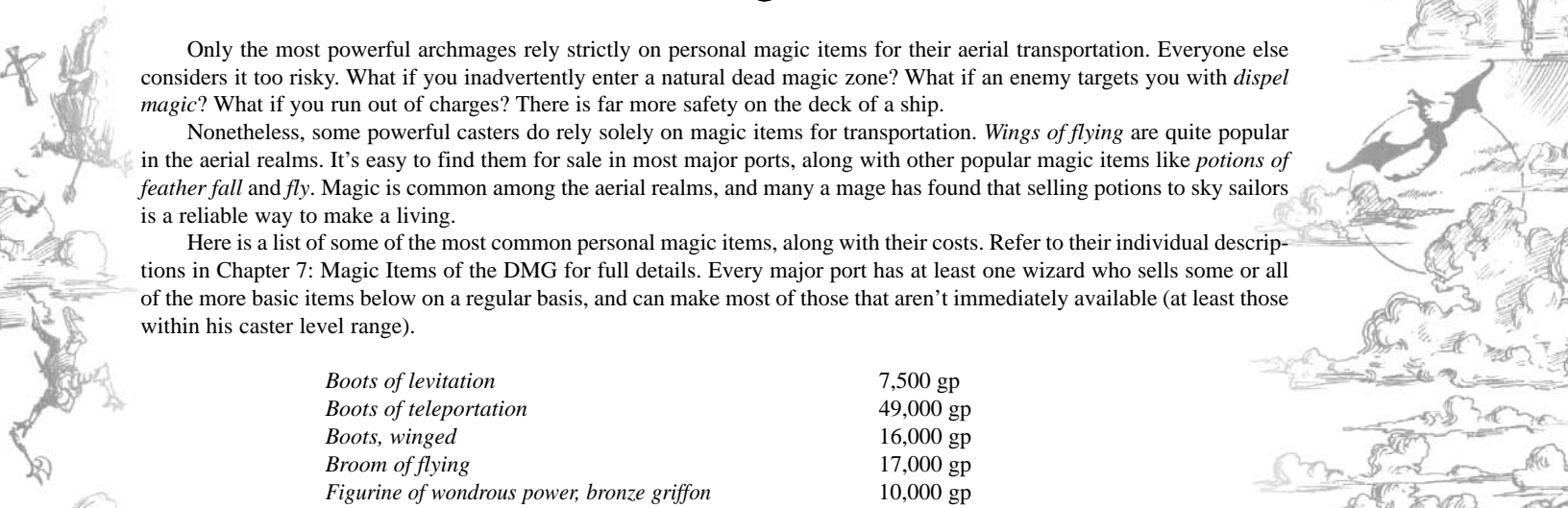

<i>Boots of levitation</i>	7,500 gp
<i>Boots of teleportation</i>	49,000 gp
<i>Boots, winged</i>	16,000 gp
<i>Broom of flying</i>	17,000 gp
<i>Figurine of wondrous power, bronze griffon</i>	10,000 gp
<i>Figurine of wondrous power, ebony fly</i>	10,000 gp
<i>Figurine of wondrous power, obsidian steed</i>	28,500 gp
<i>Immovable rod</i>	5,000 gp
<i>Potion of feather fall</i> (CL 10th)	250 gp
<i>Potion of fly</i>	750 gp
<i>Potion of gaseous form</i>	750 gp
<i>Potion of jump</i>	50 gp
<i>Potion of levitate</i>	300 gp
<i>Potion of spider climb</i>	300 gp
<i>Ring of elemental command</i> (air)	200,000 gp
<i>Ring of feather falling</i>	2,200 gp
<i>Ring of jumping</i>	10,000 gp
<i>Rope of climbing</i>	3,000 gp
<i>Scroll of air walk</i>	700 gp
<i>Scroll of feather fall</i>	25 gp
<i>Scroll of fly</i>	375 gp
<i>Wings of flying</i>	54,000 gp

## Teleportation Spells and Planar Gates

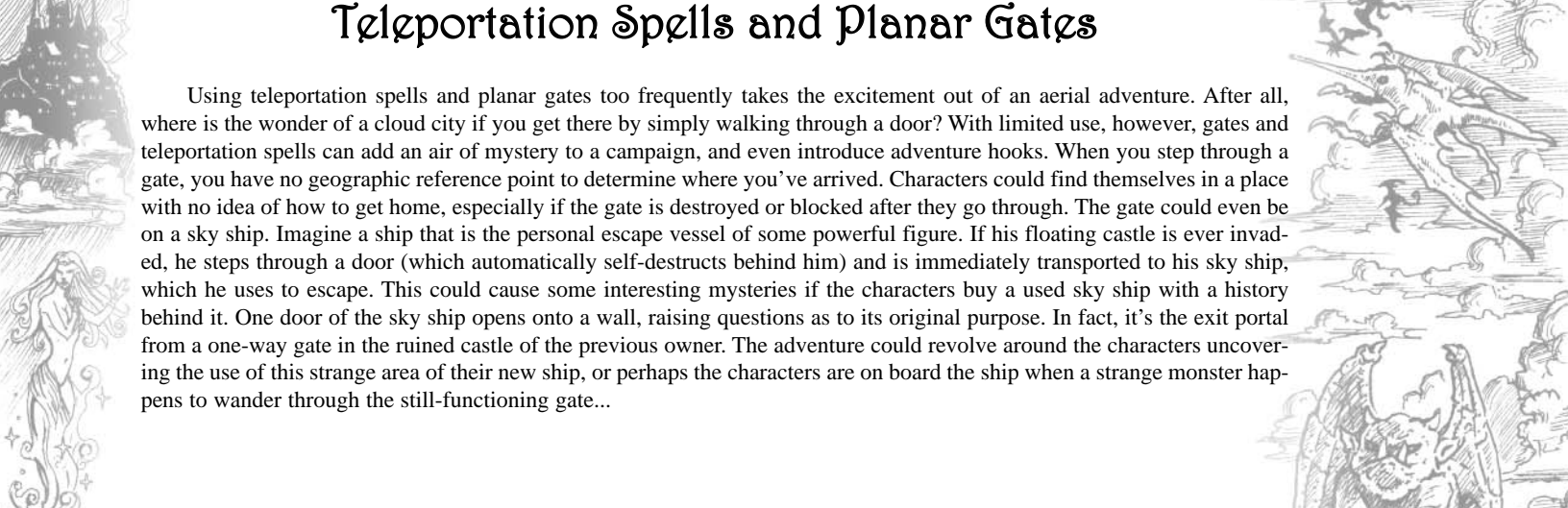

Using teleportation spells and planar gates too frequently takes the excitement out of an aerial adventure. After all, where is the wonder of a cloud city if you get there by simply walking through a door? With limited use, however, gates and teleportation spells can add an air of mystery to a campaign, and even introduce adventure hooks. When you step through a gate, you have no geographic reference point to determine where you've arrived. Characters could find themselves in a place with no idea of how to get home, especially if the gate is destroyed or blocked after they go through. The gate could even be on a sky ship. Imagine a ship that is the personal escape vessel of some powerful figure. If his floating castle is ever invaded, he steps through a door (which automatically self-destructs behind him) and is immediately transported to his sky ship, which he uses to escape. This could cause some interesting mysteries if the characters buy a used sky ship with a history behind it. One door of the sky ship opens onto a wall, raising questions as to its original purpose. In fact, it's the exit portal from a one-way gate in the ruined castle of the previous owner. The adventure could revolve around the characters uncovering the use of this strange area of their new ship, or perhaps the characters are on board the ship when a strange monster happens to wander through the still-functioning gate...



# Beyond the Clouds

After you've played an aerial campaign for long enough, it's inevitable that one of your players will ask this question: "What's further up?" In a fantasy setting, it's quite possible that the world is flat, the earth is fixed in place, and there is no vacuum of space. Sooner or later, your players will get curious and think about taking their sky ship even higher, above the clouds, simply to see what's up there.

These upper stratosphere explorations will force you to rapidly define some aspects of your world's physics. How high can the characters go? Does the atmosphere extend forever upward, or does it thin like in real life? Is there such a thing as space in your fantasy world? Can they escape the pull of gravity? Can they use a sky ship to fly to the moon?

It's up to you how you'll answer these questions. If you want to construct an elaborate planetary model, now is the time to do it. If you're not so interested in that, here are two different ways to answer these questions.

## There Is No End

The sky extends upward so high that no one has ever found a "top." Above the cloud cities that are so familiar is a vast sea of empty sky. Roughly a month's sailing straight upward, through utterly empty expanses of sky with no defining features but the sun and stars, is an upper stratosphere of floating islands, almost like an asteroid belt made up of isolated, enormous chunks of land with definite tops and bottoms. Most are so high up as to be completely invisible to the naked eye at ground or even cloud level. One in particular is so large it is visible, and it is commonly referred to as "the moon." Strange creatures live in and on top of these islands, which are few and far between. The air is uncomfortably warm because the sun is much closer at these heights. Civilization at these heights follows a completely different set of rules. All magic is fundamentally elemental in nature, drawn primarily from the massive influx of fire and air energy. Earth magic is extremely weak at these heights, and water is unheard of – these societies have never seen an ocean or rain cloud, and they live without any water at all. They're mildly bemused by the arrival of creatures from "below," but because they have incomprehensibly vast lifespans (100,000 years or more) they've seen it before and expect to see it again. These creatures have a cosmology explaining this "second world" high in the sky, and claim that if you were to burrow deep enough into the earth far below, you'd find inside a hollow sphere with "clouds" and another planet within. Whether this is true or not is unknown. They claim that if you travel for 100 years further up in the sky you'll find yet another ring of earth islands, and after that is the sun, encompassing all the sky. In reality, if the characters keep going upward they encounter a steadily increasing number of portals to the realms of fire and air. Within a few months of traveling upward the sky is literally filled with roiling flames unleashed by the constant connections to the elemental realms. The fire danger is so great they can't go on. Were claims of further life false? Or if one could pass through the flames, would one find it?

## The Planar Net

The planet is a capricious mix of elemental and planar energy endowed with life by the whims of the deities and the desultory sparks of magic. It is held together by a cosmic net woven by the elder gods when they first breathed life into the deities we currently know. This cosmic net is roughly spherical in shape, and beyond it is the silvery emptiness of the astral plane. The stars at night are the pinpricks of astral light visible through the planar net. If these apertures were ever closed, travel to other planes would be rendered impossible. Ascending in the sky past the cloud realms brings one ever closer to the planar net. The sky gradually changes to a pale, silvery blue. Regardless of speed or transportation, it takes one hundred and one days of direct travel through utterly featureless sky to reach the planar net. However, direct travel is nearly impossible because the sun hangs just below the planar net, rotating in an endless dance, and getting too close to it guarantees incineration. Instead, one must travel in a spiral-like pattern, advancing ever upward while at the same time moving away from the sun, always staying on the dark side of the world. Even in such a manner, the heat becomes increasingly difficult to bear, but clerics find their prayers are granted more easily at such heights, and sometimes have wishes spontaneously granted as the voices of their gods seem louder. After traveling in this manner for one thousand and one days (again, regardless of speed and transportation), one arrives safe (but exhausted and hot) at the planar net. The planar net looks almost literally like "solid sky" interspersed with open passages to the astral plane. The "solid sky" can be touched and it literally is solid matter, the fundamental essence from the sky is crafted. Travelers who venture from here to the astral plane arrive at the "top" of the astral plane, in a region defying geography, and may travel "down" to arrive anywhere on the astral plane within one week. They cannot travel back "up" again, however, since such travel is only possible in one direction. If one were to stay on the prime material side of the planar net and pierce it with great magics (minimum of 10th level spells, none of which have been discovered by mortals), one could enter the realms of the gods. As it is, traveling to the astral plane and then returning by way of traditional magic grants an acute understanding of the nature of the world. This has great combat benefits but they're fundamentally irrelevant because the few travelers to have made this lengthy journey invariably become ascetics or cloistered monks, where they spread the word of truth and light to those who will listen to their clarification, crystal-clear vision of the nature of reality.





fig.3  
Elven  
Deckbow

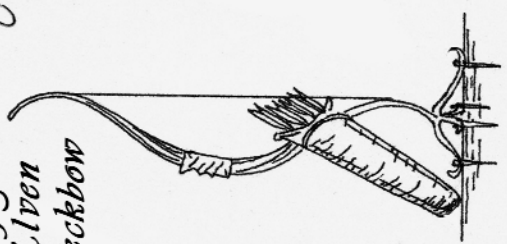

fig.4  
Bow and Hull  
Detail

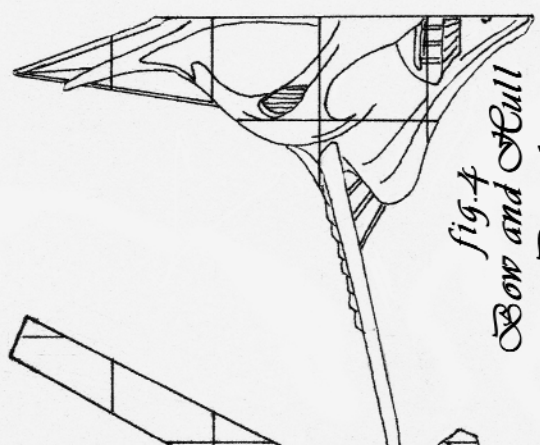
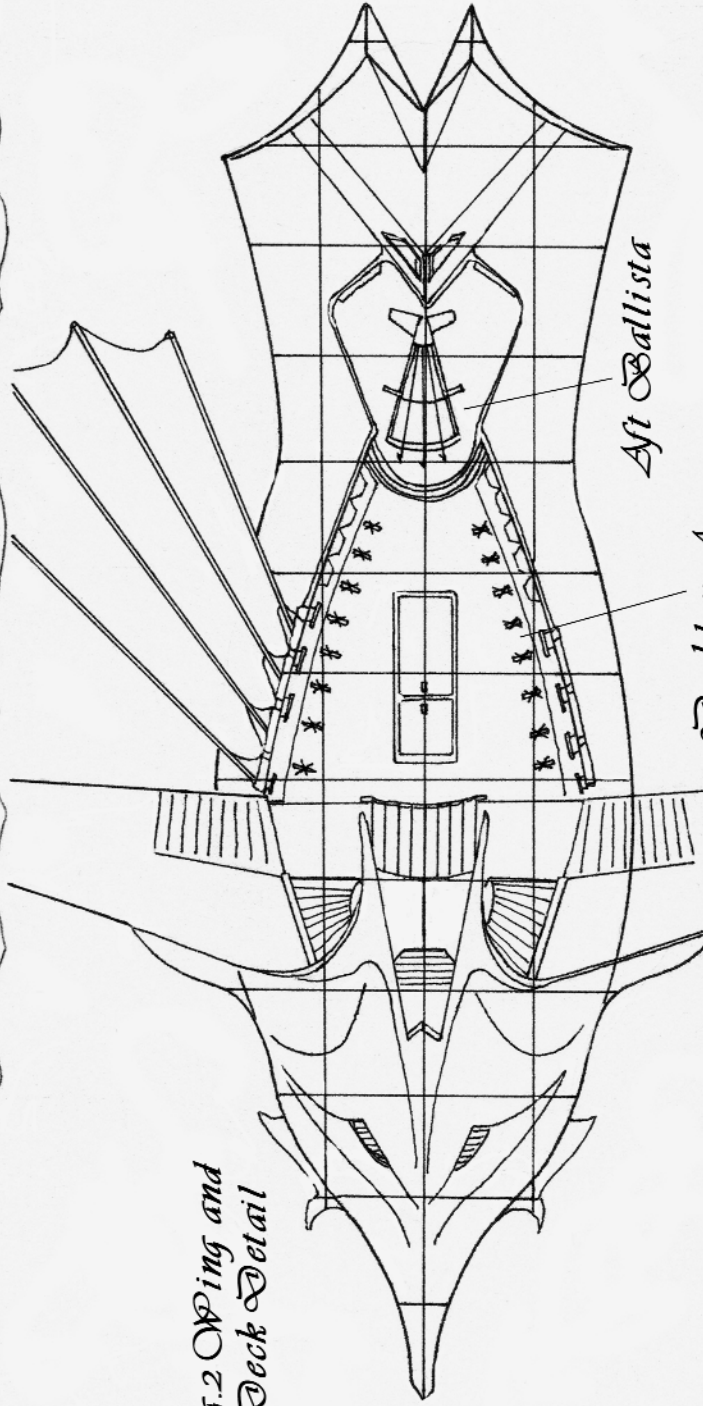

fig.2  
Wing and  
Deck Detail



Aft Ballista

Deckbow Array

Boarding Wingspan  
70 ft.

Scale  
1 square =  
5 ft. sq.

fig.1 The 'Elavanya'

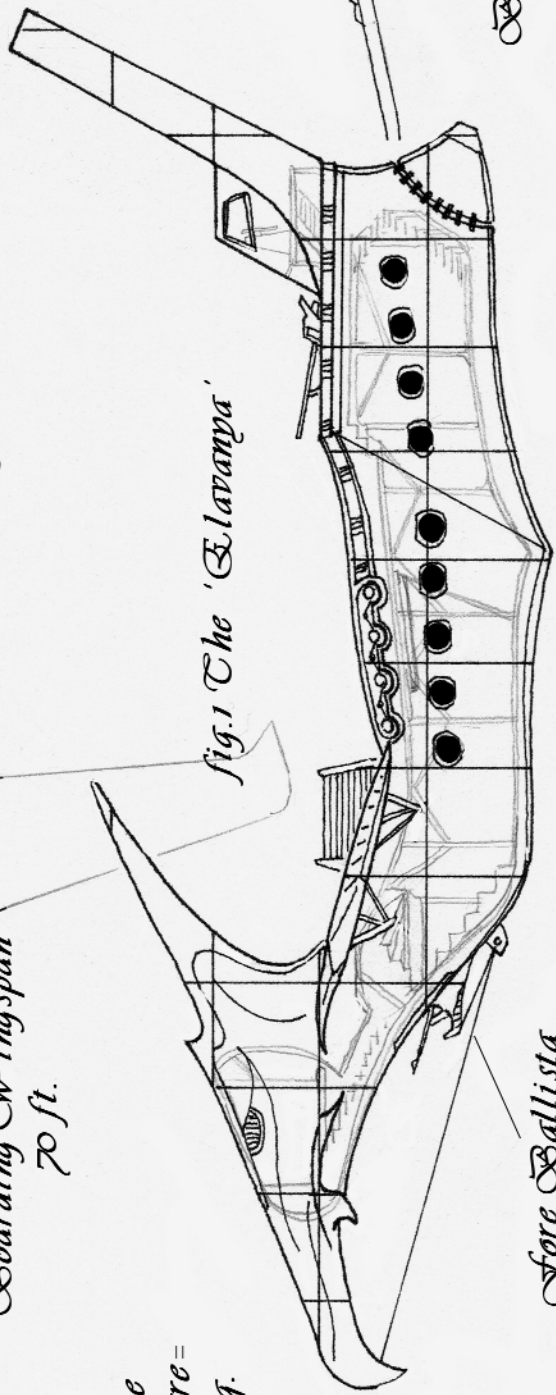

Fore Ballista

# Wky Elf Airhawk

Stats on page 49

Fig.3 Landing Mechanism  
Down and Retracted



Slave Coccons

Ballista

Ramming  
Bow

Fig.2 Interior  
Detail

Crew Quarters

Fig.1  
Sailing Detail

Scale:  
1 square =  
5 ft. sq.

# Arachial Spinner

Stats on page 49

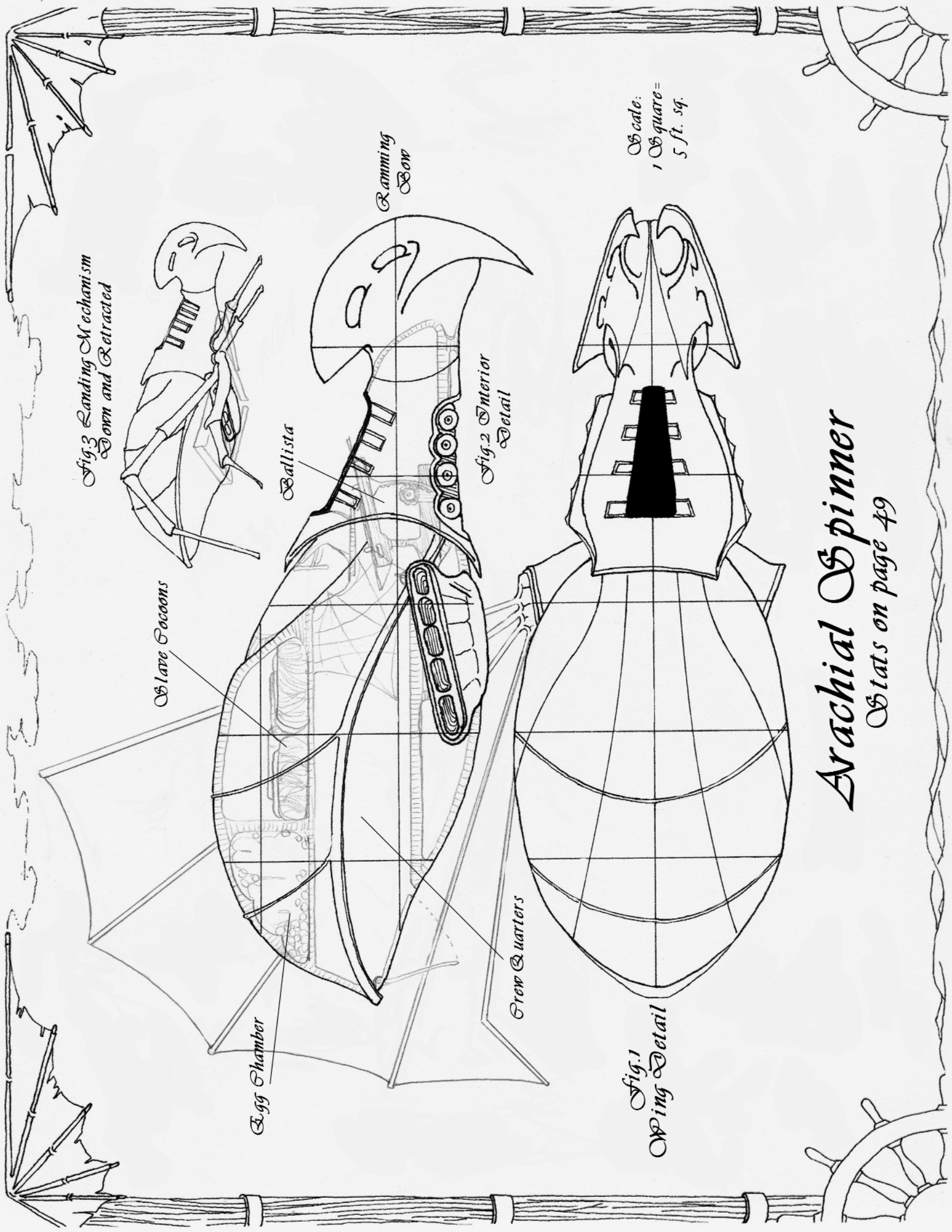

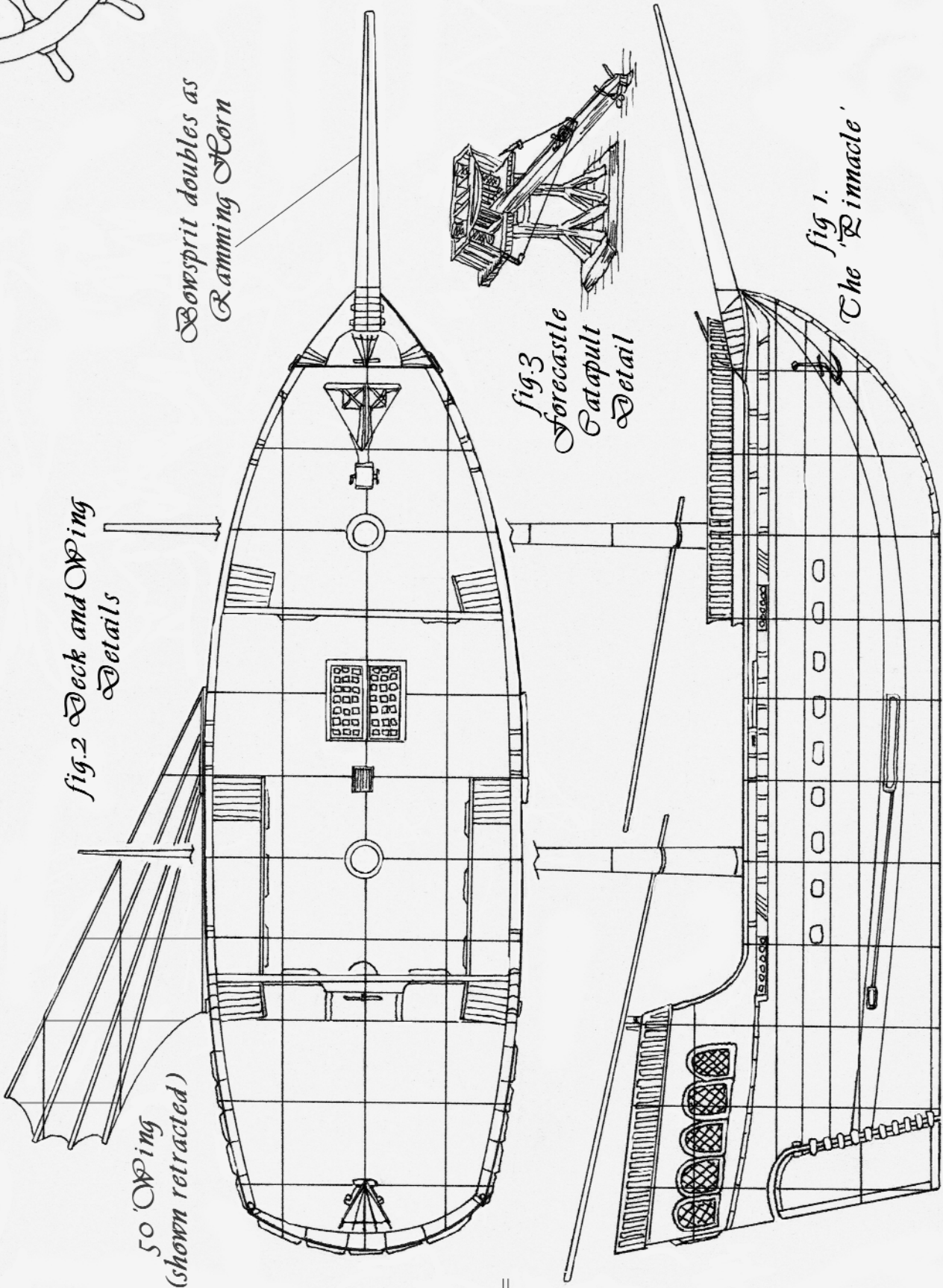

fig. 2 Deck and Rigging Details

50' O'ring  
(shown retracted)

Bowsprit doubles as  
Ramming Horn

fig. 3  
Forecastle  
Catapult  
Detail

fig. 1.  
The 'Pinnacle'

Scale:  
1 square =  
5 ft. sq.

*Javelin*  
Stats on page 51



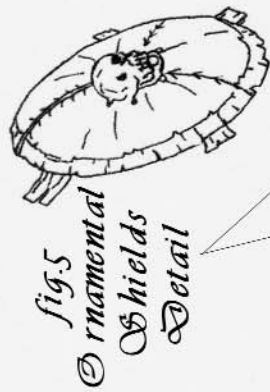

fig.5  
Ornamental  
Shields  
Detail

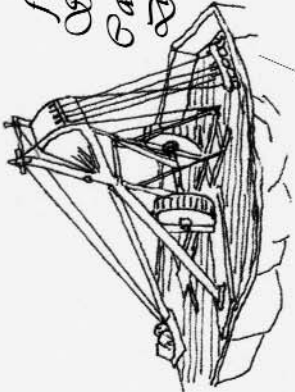

fig.6  
Small  
Catapult  
Detail

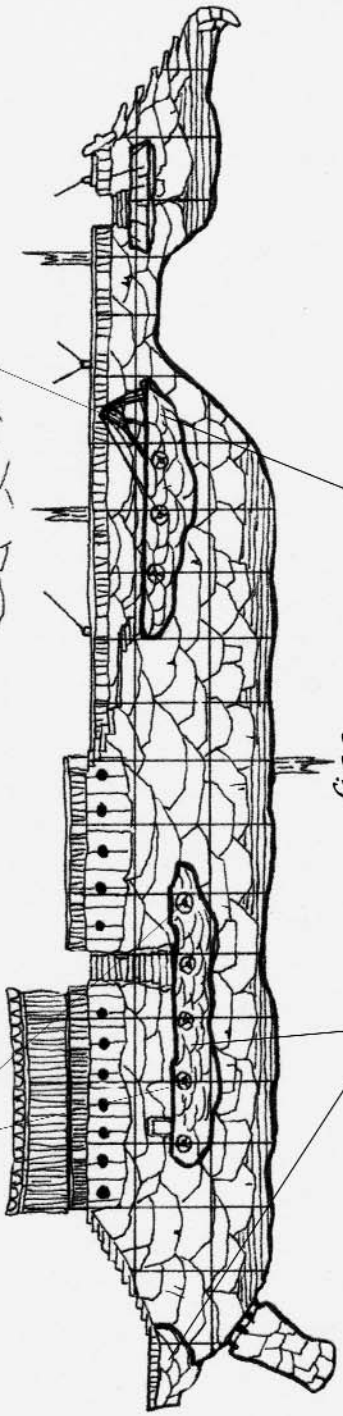

fig.2  
Battle Turrets and Catapults  
Scale: 1 Square = 5 Ft. sq.

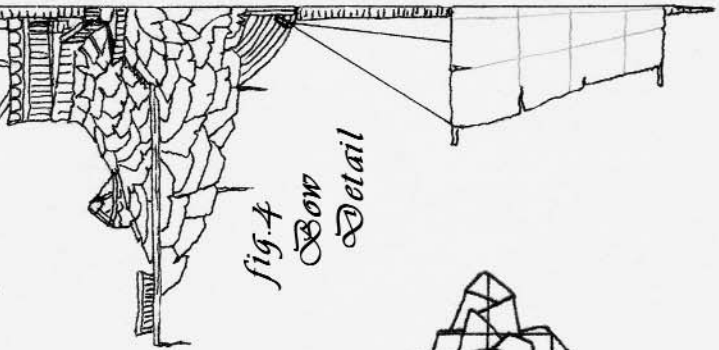

fig.4  
Bow  
Detail

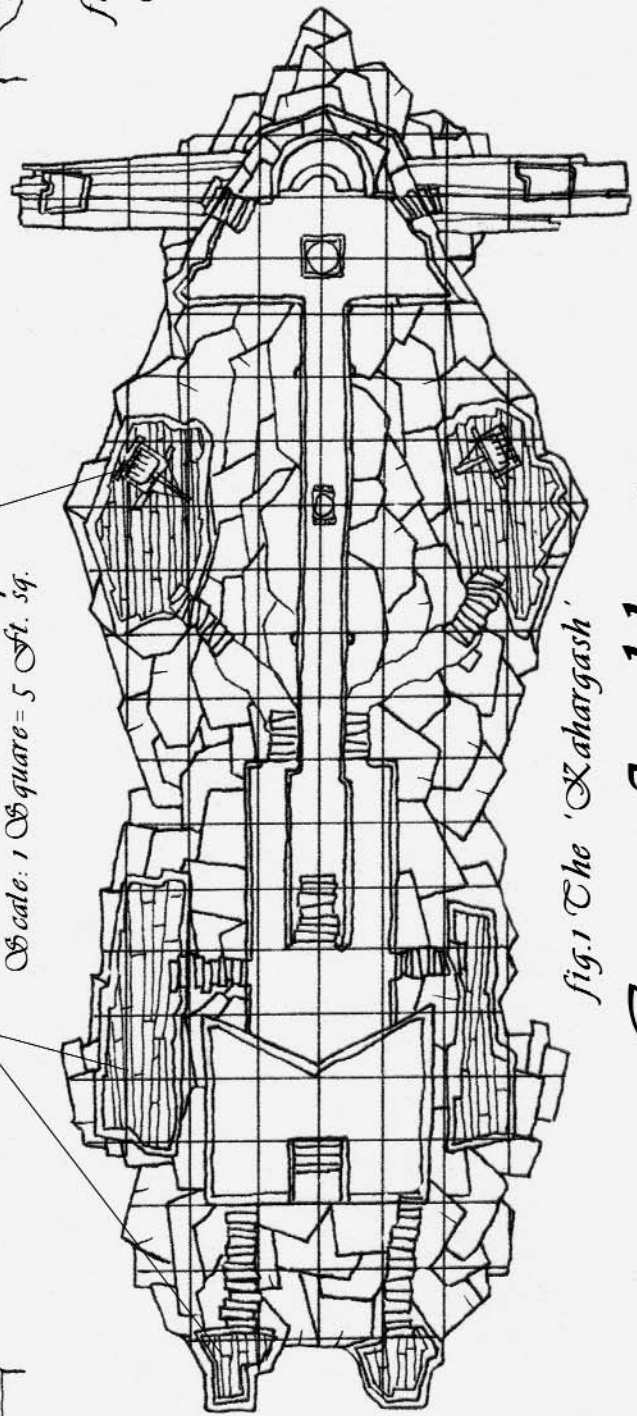

fig.1 The 'Lahargash'

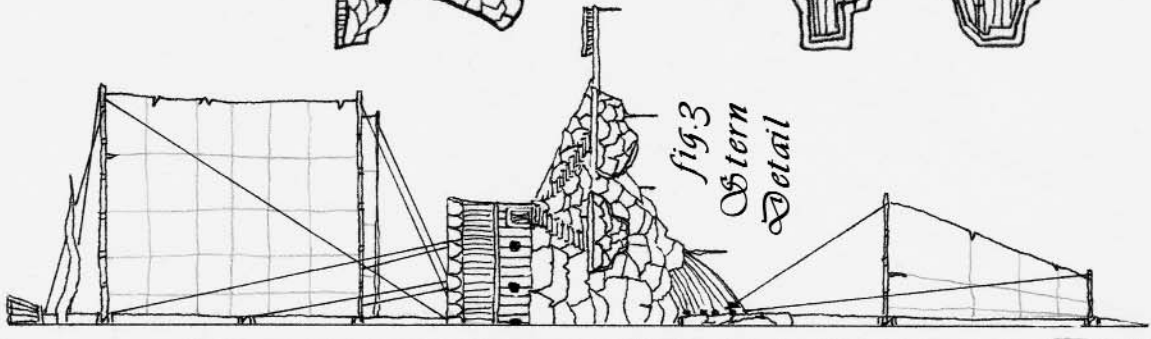

fig.3  
Stern  
Detail

# Drc Junkheap

Stats on page 51



fig. 3  
Natural Cavities  
form  
Belowdecks

fig. 2  
Deck Details  
w/ Ballistae

Roots Bind  
to form  
Ramming Bow

fig. 1  
The 'fallarion'

Summer  
Growth  
provides concealment  
for Archers

Scale:  
1 square =  
5 sq. ft.

# Elf & kpyrunner

Stats on page 50

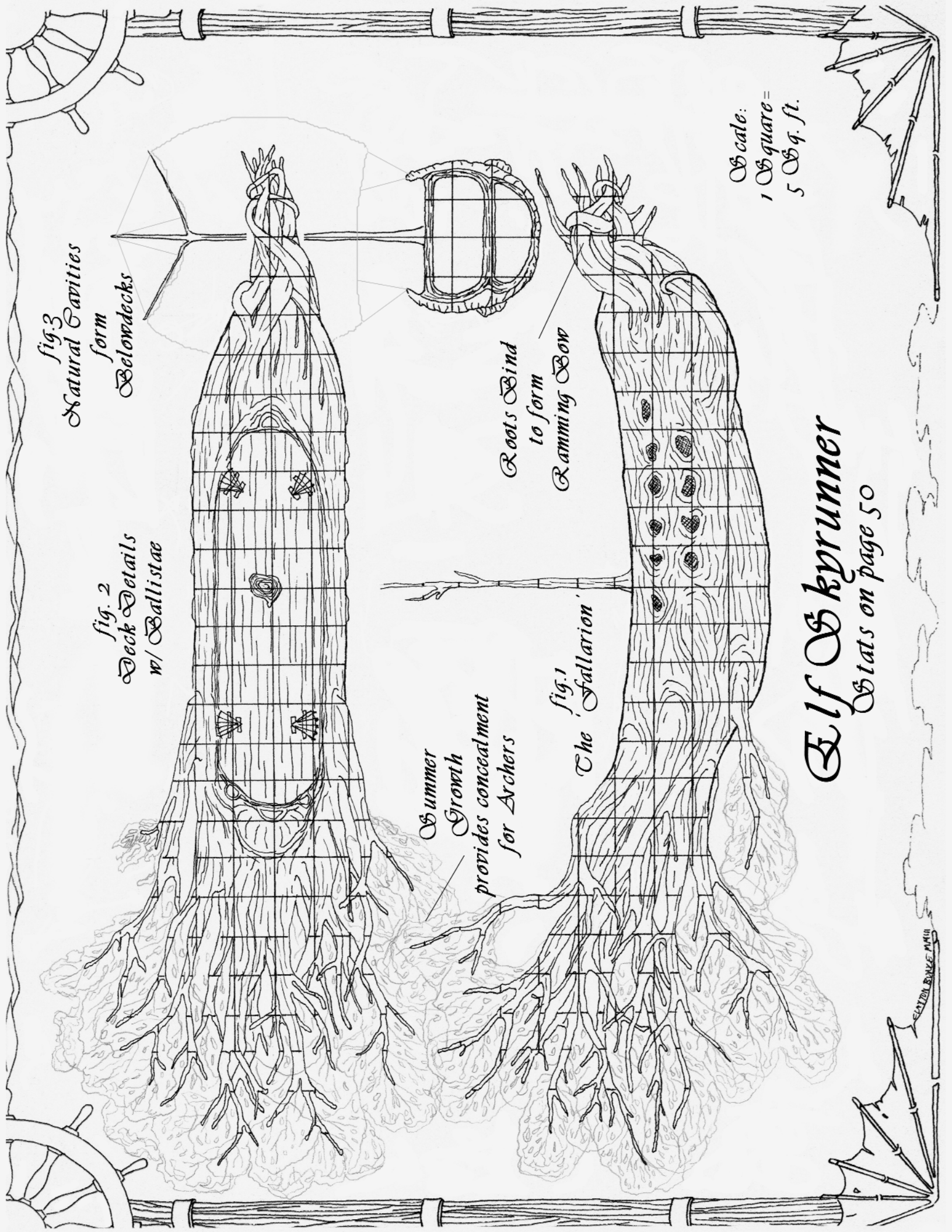

fig. 4

Bow detail  
Overlapping  
Copper Plates

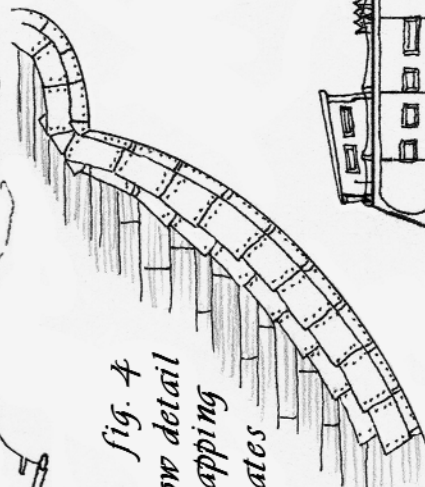

fig. 6

Captain and  
Crew Quarters

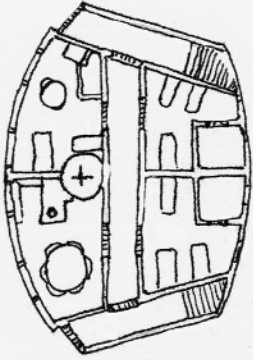

fig. 7

Opening detail

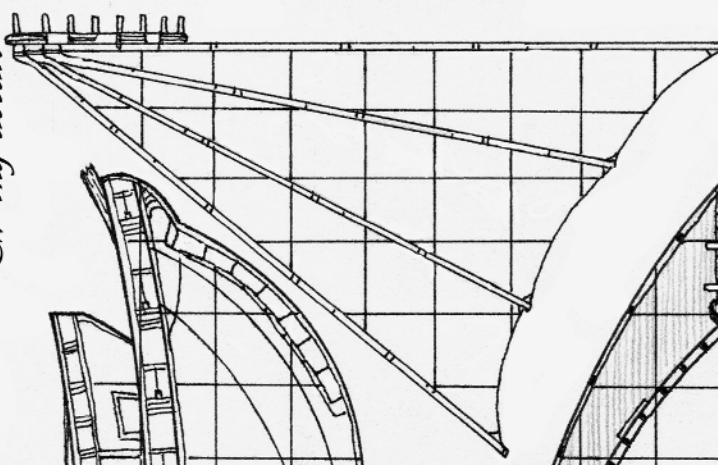

fig. 5 - Cargo Loading

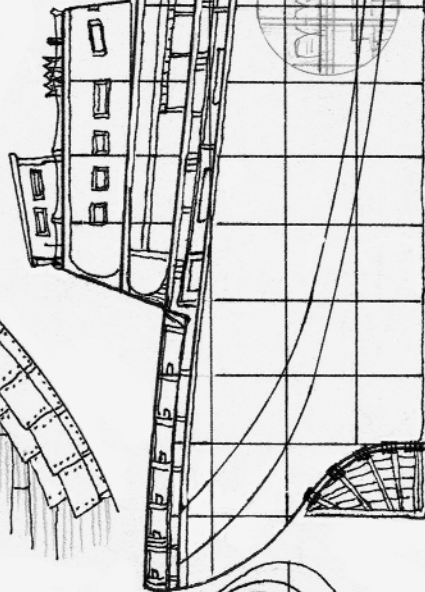
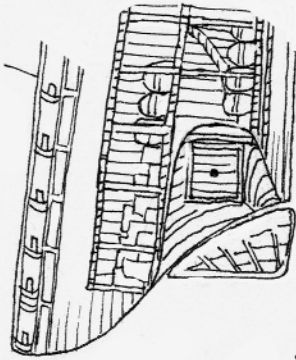
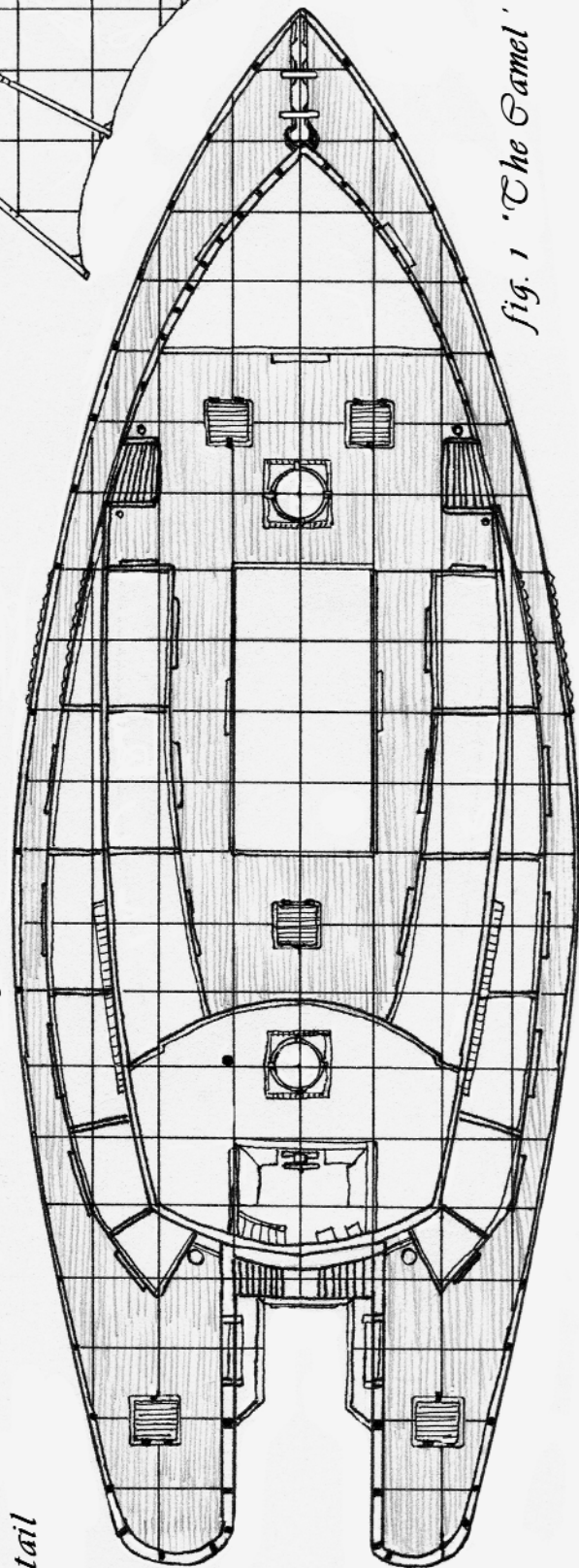

fig. 2 Hold Detail

fig. 3 Stern Detail



Scale:  
1 square =  
5 ft. sq.

fig. 1 'The Camel'

COW

Stats on page 52



Spiral Staircase  
to Aft Deck

fig.2 Deck Detail

Warhawk utilizes Mobile Catapults

Main Deck

Tower Deck

Foreward-  
Facing  
'Archer Turrets'

Wingspan  
320 ft.  
Overall

Scale:  
1 square =  
5 sq. ft.

fig.1  
'The Renar'

Rudder  
Length  
60 ft.

Bomb Cannisters

Foredeck  
Ballista

# Ship Elf Warhawk

Stats on page 52

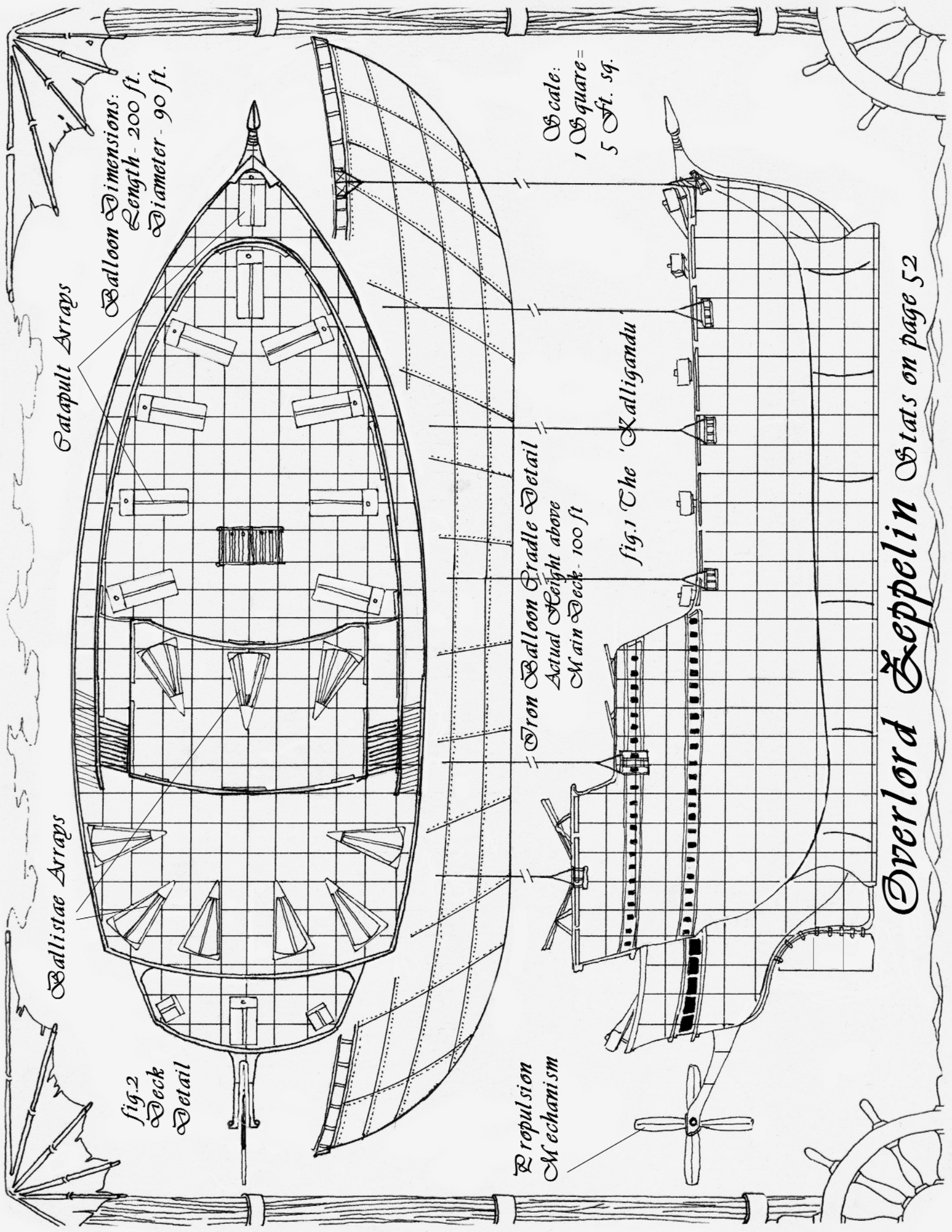

Balloon Dimensions:  
 Length - 200 ft.  
 Diameter - 90 ft.

Catapult Arrays

Ballistae Arrays

fig. 2  
 Deck  
 Detail

Scale:  
 1 square =  
 5 ft. sq.

Iron Balloon Cradle Detail  
 Actual Height above  
 Main Deck - 100 ft

fig. 1 The 'Xalligandu'

Propulsion  
 Mechanism



# Other Products from Goodman Games

Goodman Games publishes a wide variety of high quality games. For more information, please visit our web site at [www.goodman-games.com](http://www.goodman-games.com), or write to Goodman Games, 672 Woodland Ave. SE, Atlanta, GA 30316.

## The Wanderers Guild

Beautifully illustrated monster manuals designed with a spirit of adventure.



**Monsters of the Endless Dark**  
GMG4000, \$18.00  
Nominated in 2003 Gen Con  
ENnie Awards:  
Best Graphic Design  
Best Monster Supplement

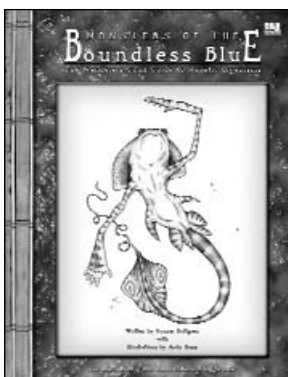

**Monsters of the Boundless Blue**  
GMG4001, \$18.00

## Dungeon Crawl Classics

New adventure modules with a classic feel. Retro design and art, with a back-to-basics approach to the adventure.



**Dungeon Crawl Classics #3:  
The Mysterious Tower**  
GMG5002, \$10.99



**Dungeon Crawl Classics #4:  
Bloody Jack's Gold**  
GMG5003, \$10.99

## The Complete Guide

Monster sourcebooks covering everything from culture to combat – including guidelines for PC play of the creatures.

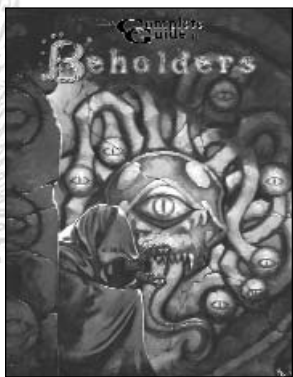

**Complete Guide to Beholders**  
GMG3004, \$22.00

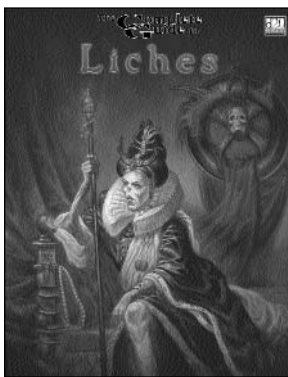

**Complete Guide to Liches**  
GMG3003, \$13.00

Also available:

**Complete Guide to Wererats**  
GMG3001, \$11.00

**Complete Guide to Treants**  
GMG3003, \$13.00

**Complete Guide to Doppelgangers**  
GMG3000, \$11.00

**Complete Guide to Drow**  
GMG3006, \$13.00

## Adventure Guides

World-neutral sourcebooks for playing unusual kinds of adventures, designed to be used in ongoing campaigns.



**Underdark Adventure Guide**  
GMG2003, \$28.00

## Other Titles

From magazines to martial arts, from dinosaurs to drow, Goodman Games has got it!

**DM Campaign Tracker**  
GMG9700, \$4.99

**EN World Player's Journal**  
GMG9004, \$5.00

**Beyond Monks:  
the Art of the Fight**  
GMG4300, \$20.00

**Dinosaur Planet:  
Broncosaurus Rex**  
GMG1000, \$20.00

**Morningstar Campaign Setting**  
GMG4100, \$30.00

**Power Gamer's 3.5  
Warrior Strategy Guide**  
GMG4310, \$19.00





Requires the use of the *Dungeons & Dragons Player's Handbook*, published by Wizards of the Coast, Inc. This product utilizes updated material from the v.3.5 revision.



# AERIAL ADVENTURE GUIDE

Sky ships, flying castles, cloud cities, and airborne monsters! The Sky Captain's Handbook is a complete sourcebook with everything you need to run an aerial campaign. With its focus on inspiring ideas for unique aerial adventures, this book contains new character options, races, monsters, feats, items, sky ships, and aerial combat rules that can be integrated into any fantasy campaign. After all, no matter what world sits at ground level, anything can float above.

- Fully developed background and rules for the three major races of the sky, complete with specialized feats for new races
- Complete sky ship rules, including stats for dozens of different designs and deck plans for the 8 most common models
- A complete aerial realm ready for integration with any campaign
- Simple yet complete aerial combat rules, which allow you to run a skyship battle without bogging down the game
- Dozens of aerial monsters fully fleshed out with racial stats for humanoids, NPC stats for leaders, and advanced stats for higher CRs
- Rules for heroic legacies that allow first level characters to take to the skies
- Guidelines for running an aerial game, integrating it with an ongoing campaign, and using the air to inject an element of the fantastic into your game

The Aerial Adventure Guide is a stand-alone book. It is 100% world-neutral and ready to be integrated into any campaign.



**\$ 27.99** USA

SKU CMG2004

*Dungeons & Dragons®  
and Wizards of the Coast®  
are Registered Trademarks  
of Wizards of the Coast,  
and are used with permission*

