

Advanced Dungeons & Dragons®
Official Game Adventure

Desert of Desolation



TSR, Inc.
PRODUCTS OF YOUR IMAGINATION™

Table of Contents

Foreword	3
Chapter 1: Background And Storyline	4
Chapter 2: Judging Notes For The Referee	6
Chapter 3: Setting Up The Campaign	10
Chapter 4: Bralizzar, Gateway To Raurin	12
Chapter 5: Across Northknife Pass	19
Chapter 6: Desert Of Desolation	22
Chapter 7: Sunken City Of Pazar	36
Chapter 8: Tomb Of Amun-Re	40
Chapter 9: Oasis Of The White Palm	62
Chapter 10: Temple Of Set	74
Chapter 11: Crypt Of Badr Al-Mosak	80
Chapter 12: Lost City Of Phoenix	86
Chapter 13: Skysea/The Cursed City Of Stone	94
Chapter 14: Lost Tomb Of Martek	108

Original Module Design: Tracy Hickman, Laura Hickman, and Philip Meyers
Additional Design: Peter Rice and Wm. John Wheeler
Revision: Wm. John Wheeler
Editing: Curtis Smith, Edward Sollers, Marlene Weigel, and Wm. John Wheeler
Cover: Keith Parkinson
Cartography: Dennis Kauth, Ron Kauth, Dave LaForce, Steve Sullivan, and Stephanie Tabat
Typography: Betty Elmore

Distributed to the book trade in the United States by Random House Inc., and in Canada by Random House of Canada, Ltd.

Distributed to the toy and hobby trade by regional distributors.

Distributed in the United Kingdom by TSR UK Ltd.

©Copyright 1987 TSR Inc. All Rights Reserved.

This adventure is protected under the copyright laws of the United States of America. Any reproduction or other unauthorized use of the material contained herein is prohibited without the express written permission of TSR Inc.

First Printing May 1987

Printed in the U.S.A.

Foreword

This has been an ambitious project. It is difficult to revise the good work done by someone else and to add material to it that does not destroy the flavor of the original. To do this has been my task.

Tracy Hickman, Laura Hickman, and Philip Meyers provided an excellent set of adventures in the original Desert Of Desolation Series, I3 through I5. The story that held these adventures together was of a campaign style, an epic quest against seemingly insuperable odds. To this material, Peter Rice and I have added new designs, expanding on some of the open ends that were left behind in the original works. We designed the adventure map, tying together all of the adventure areas, and we created the ancient alphabet used on all of the inscriptions. With the help of Jeff Grubb, Peter and I have expanded the history, storyline, and legends to tie together the adventures and weave in the new material, creating a viable campaign in the Forgotten Realms. In addition, as editor, I have completely revised the format, rewritten much of the text, and added significantly to the judging notes.

What has resulted amazes me. The work has a luster and sparkle that I wish every one of my own designs had. I guess that is what happens when you take a jewel and polish it. It is enjoyable to read and the playtests of the revised work were a lot of fun.

Here you have the Desert Of Desolation. You have a wonderful adventure ahead. I wish I could join you.

Wm. John Wheeler
March 31, 1987

Chapter 1: Background and Storyline

The Plot Line

Play will begin with an encounter, wherein the players will probably use a teleportation device they discover to escape from a seemingly-impossible situation. They also will discover a waylaid message to Elminster the Sage detailing the discovery of prophecies requiring immediate attention. The teleportation amulet that will take them far to the southwest, depositing them in Bralizzar, a frontier town nestled in the mountains known as The Dustwall.

Discovering themselves in the sitting room of a wizard, actually quite pleased by their intrusion, they will be shown a map fragment of The Desert of Desolation, told details of the prophesy, and be asked to undertake a quest to forestall the events prophesied. Should they refuse, other, more physical, means will be used to insure their cooperation.

The prophecies come from Martek, Grand Vizier of Raurin, called "The Greatest of Mages." One thousand years ago, Martek imprisoned an evil efreet of great power. He realized that the efreet would eventually release himself and would gather evil minions to wreak his vengeance on the land and peoples of the desert. He also foresaw that he could minimize the damage from the vengeful efreet if he were somehow able to be brought back to life at the proper moment. Thus, he set up a magical quest for a band of heroes whose ultimate goal would be to break into his Inner Sanctum and resurrect him at just the proper moment, about 1000 years after his death.

Fearing that to leave his tomb open would be to risk its plunder and the foiling of his scheme, he would have to make the quest a difficult one, one of many parts, all of which were needed to be successful. He enchanted five large gemstones, which he called the Great Stars, or the Star Gems; all of these would be necessary to gain entrance to his tomb and resurrect him. He scattered these among the sheiks, pharaohs, and other rulers of the desert. He gave magical instructions about the way the gems should be treated and placed clues to their whereabouts in several places, knowing that the wizards of a later age would piece together parts of the story.

He engineered the imprisonment of a great djinn to combat the efreet while the quest for the stones was undertaken. This would act as a safety valve in case the quest failed. He placed lingering enchantment on a revered place, so that its rulers would always have the key to the djinn literally in the palms of their hands.

Finally, he devised the greatest scheme of all. He set one of the star gems to guard the efreet, knowing that his heroes of the future would actually release the efreet in their quest. The efreet would begin to wreak vengeance and would further expend power combatting the

djinn. Then, when Martek was released, he would be able to banish the efreet from the land forever.

The Desert of Desolation abounds in clues and artifacts from Martek's quest. Several months before the beginning of play a wizard/scholar managed to decipher an ancient tome actually prepared by Martek to reveal key pieces of his quest at this time. The tome states that an evil efreet will soon be released on the land and that a band of heroes is needed to gather the five magical Star Gems of Martek, now scattered in the Desert of Desolation. These stones would allow the heroes to enter Martek's tomb, where they could release Martek's fabled Sphere of Power to destroy the efreet.

Fulfilling the prophesy is the story that will unfold for the player characters. They will, by choice or force, go north to Raurin, to the cursed area called The Desert of Desolation. Once a fertile land, ruled by benevolent Pharaohs, only ruins now remain, the bleached bones of great cities awash in shifting sands.

The heroes-to-be will travel to the now-sunken ruins of Pazar, where they will find one of the Star Gems. Actually, they will also release the efreet, if all goes as Martek intended, and this will seem to fulfill the events he foretold. They will travel to ruined Terbakar and meet the spectre of Amun-Re, in whose theft-proof tomb they will find a second Star Gem and incidentally break a curse that will restore water to the desert.

Making friends (and enemies) in the Oasis of the White Palm will lead the adventurers to the Temple of Set buried beneath the oasis. There, they will find a third Star Gem. An excursion to the crypt of Badr Al-Mosak will bring them face-to-face with the evil minions already gathered by the efreeti they freed, as well as another Star Gem.

A journey to the ruined city of Phoenix will allow the adventurers to release the djinn imprisoned there. He will fulfill his part of Martek's plan and begin to combat the efreet, who, unfortunately, awaits him. Efreet and djinn lock in a titanic struggle against one another, unleashing firewinds and icestorms that rain down upon the desert peoples.

Finally, the quest will take the heroes across the glass of Skysea, created by the original battle between Martek and the efreet. There, in the ruined city of Medinat Muskawoon, they will search for the final Star Gem, the magical compass that will guide the heroes to Martek's tomb. To fulfill the prophesy and save the land from total destruction, all that remains is to gain entrance to the hidden Citadel of Martek.

Inside, they will discover that they are not alone, for others have managed to discover the entrance to the Citadel. Without at least three Star Gems, however, these people were fated to remain imprisoned in the entry garden of the

Citadel. Gaining entrance to the Grand Hall of the Crystal Prism, the heroes will find that there are three tests at which they must succeed before they can gain the Inner Sanctum, the resting place for Martek and his Sphere of Power. In order to activate the key to the Inner Sanctum, they will have to best three unusual adventure areas — the Black Abyss, the Mobius Tower, and the Crypt of Al-Aliak.

Once in the Inner Sanctum of Martek, the adventurers will have to use the Star Gems to release Martek's Sphere of Power. Though thought to be a magical artifact, the Sphere is actually Martek himself. The player characters must figure out how to bring him back to life so that he can use his power to destroy the efreeti. Once he has been brought back to life, Martek will reward the heroes and return them to wherever in the land they desire to be, allowing them to witness the fulfilling of his prophesy as he banishes the efreet.

General Background Information

There is background information presented at the start of each chapter. The information in these Background sections is specific to the area and play described in the chapter. The background information presented here is more general. It ranges from a condensed history of the area to information about Martek and his quest.

Use this information when the PCs are dealing with a knowledgeable NPC, such as the wizard Aman Al-Raqib. Remember, when giving out information, do not be too specific if it will affect play.

Travel Through The Desert Of Desolation

At one time, when the River Athis flowed, trade between the cities of the north in Mulhorand and Semphar and those in Durpar passed through the great deserts of Raurin by following that great river. The River Athis sprang from a magical fountain in Terbakar, the rich and verdant capital of the Bakar, a jewel in the desert. Its pharaohs had ruled there for time out of mind, and though its libraries were noted in some circles, it was the Waters of Athis revered by the dwellers of the desert. The River Athis that sprang from Terbakar gave life to a long and sinuous corridor from there generally northward, passing by the garden city of Pazar, the sacred White Palm, the city of Carthag now called Phoenix, and beyond to the lands where the legendary Martek had his domain.

When the Pharaoh Amun-Re called down a curse on his people and the River Athis ceased

to flow in response, the fertile river valley dried up. So, too, did the teeming life made possible by the flow dry up. With life in the desert nearly impossible, the trade routes that followed the River Athis became drifted over with sand. With the curse came universal dryness, and the area was renamed the Desert of Desolation to reflect that. The cities of Durpar and the southern trade roads were cut off from Mulhorand and Semphar.

But while the Desert was dead, the rest of the world was not, and a barrier of sand could not last forever. If it was possible to cross the desert along the banks of the River Athis while life-giving water flowed there, it was still possible once those waters were lost to Amun-Re's curse. The rich and populous lands to the north virtually demanded trade begin once again. That trade could have gone to sea through the Golden Water and around to the Alambar Sea, but the voyage was long and dangerous. Better, reasoned the merchants, to find a way across the Desert of Desolation, the rest of Raurin, and Plains of Purple Dust to the wealthy and ancient cities of Gheldaneth, Unthalas, Jhandyl, Phannaskul, and Phelzol.

At last, the pressure from the merchants was too great, and a caravan, one modest in size, well guarded, and supplied, left the town of Bralizzar, once the staging point of the trade north. It crossed the intervening sand guided by a few Raurindi who only knew of the area, long desolate, from stories at the knees of their elders. The trek to the dry valley of the Athis was killing, and tale these intrepid traders brought back was one of desolation and danger. But it could be done, and the pressure to trade had an outlet. Thus entered the Sand-voyagers Guild.

The Raurindi / Durpari Conflict

The Durpari saw the re-establishment of trade across the desert as a way to return to their heritage. Traders to the core, they had plied their wares in the Athis river valley before the curse had made it barren. They saw caravan trade between the remaining oases as the manner in which they could return.

They were driven by two motives beyond those of trade alone: as members of the one god Anu, they were sworn to the destruction of the idols of the older gods of the Raurindi, and they were secretly ashamed that they had deserted the land to the Raurindi. Thus they came back to the desert with the glint of gold in their eyes, and a hatred of the Raurindi and all they stood for in their hearts.

While the Raurindi had protected the temples of the old gods, the Durpari were bent on their destruction. As the Durpari swept into Bralizzar, the Dustwall Mountains, and the Desert of Desolation, they pushed the Raurindi before them . . . or destroyed them.

The Durpari

The Durpari are a civilized people who are traders to the core. Because of this, they have developed great cunning in business, and their commitment to the truth is less than total. They prefer to talk, rather than fight, though they have some of the most fearsome troops in the southern lands, their dreaded Lancers and Airlancers.

It was the Durpari who established trade through the deserts of the south, and it was the Durpari who re-established it when trade became nearly impossible following the curse of Amun-Re. The Durpari are the only group of people who venture through the Desert of Desolation with regularity. Although they often go on trading missions, they prefer to remain at home, usually at an oasis fortress or other trade center.

The Durpari worship one god, whom they call Anu. Their religion deems as heretical the worship of many gods, and they are duty-bound to destroy idols and temples dedicated to the "old" religions.

The Durpari Airlancers fly on pegasi they breed for the purpose. They can communicate with their beasts in very complex ways.

The Raurindi And The Dervishes

As a people, the Raurindi became nearly extinct when their lands turned to desert millennia ago. Those who were left became desert nomads, a dark people, rough from the desert winds and sands. Hot-tempered and emotional, they do not generally care for outsiders. They are somber, pessimistic, and almost always bad-mannered, but they are scrupulously honest and completely fearless. To their friends, they are generous and forgiving, except of a personal insult.

Many Raurindi have since been assimilated into the Durpari, particularly in areas within and bordering the great deserts. Most of these have converted to the "True Faith" of the Durpari, who worship the one god Anu. Nevertheless, some of the Raurindi cling secretly to the old ways. Called Dervishes, they are aliens, outcasts, and even outlaws wherever they go. In fact, because they feel that their god has turned away from them in relegating them to the desert, not only do they worship the old religions, but they now fanatically protect the religious freedoms and holy places of all peoples, whatever their practices or beliefs. They hate robbers of graves and tombs, and protect such places from "infidels," tending to make encampments nearby. If they find a holy item or place has been looted or damaged, they will mark the vandal/thief for *Bloodquest*. This means that they will use their considerable tracking ability (the same as rangers) to hunt down and destroy the one so marked. The final stroke is carried out under the trembling, vibrating scream of any Dervishes at hand,

fighting to the death. This has spawned a desert proverb: "Woe be unto him who puts blood in the eye of the Dervish."

Star Gems Of Martek

Martek gave five Star Gems to the rulers of the lands crossed by the River Athis, one to each. The Star of Mo-Pelar, a fist-sized opal, he gave to the Pharaoh Amun-Re, who locked it in his theft-proof tomb. The Star of Aga-Pelar, a huge sapphire of midnight black with a star of purest white, he gave to the Lord of Pazar in return for keeping Khalitharius prisoner. The Star of Shah-Pelar, a very large faceted ruby, he gave to a pharaoh whose name is lost in antiquity; the gem was stolen by the evil Badr Al-Mosak, and is said to be buried with him. The Star of Khan-Pelar, an enormous clear crystal, is thought to be buried near the White Palm. The Star of Melos-Pelar, a faceted amethyst ball, was taken into the Cursed City of Stone, never to be seen again. All five are needed to locate Martek's Tomb.

The Sphere Of Power

Legend says that Martek's Sphere of Power was buried with him. Using that wondrous tool, Martek bested the evil Efreet Pasha Khalitharius in a magical battle that has not been seen since. The very desert sands flowed like water before the efreet was imprisoned.

The truth is that Martek's knowledge and wisdom are his "sphere of power." They indeed lie with him in his Citadel, and when he is brought back to life, he will use them to banish the evil efreet Khalitharius forever.



Chapter 2: Judging Notes For The Referee

This adventure is designed for a party of six to eight player characters of 5th to 7th levels. A balance of character classes is suggested, for a wide variety of problems will confront the players. Each character class will certainly have its moments to shine.

About The Presentation

This is a campaign-style product. It is an epic adventure featuring the player characters as heroes. The story line is meant to be usable in any campaign, beginning at any location. We feel that it is at its best when played that way.

Nevertheless, the adventure has several distinct parts, each usable as a scenario on its own. For this reason, the adventure is presented in sections, each one a chapter in this booklet. If you choose to do so, you may lift a section from the adventure and play it separately, though some work would be necessary to fit it into ongoing play.

Furthermore, there are three places where beginning play makes sense. These places represent the starting points for the three I Series modules as they were originally published. One place is at the tomb of Amun-Re, ignoring the preparatory campaign material. A second is in the Oasis of the White Palm, assuming that the events at the pyramid of Amun-Re are things of the recent past. A third is at the Pillars of Martek, wherein all of the quest has been completed and the heroes only need to gain entrance to the tomb.

The information needed to run this adventure is presented in the same way for each section and part of a section. The various types of information are given below.

Boxed Text

This is material meant to be read to the players unless specific circumstances in your game prevent their knowing the information given. In general, boxed text will give what the adventurers could see, hear, or otherwise perceive before actually beginning to interact with the adventure area. Indoor and nighttime descriptions were written assuming that the adventurers are using a torch or lantern to see by, thus illuminating a 30-foot radius area.

For example, boxed text for a room would give a brief description of the room's contents as seen from the doorway; this would include a description of the room's inhabitants. Another example of boxed text would be introductory material that would set the stage for subsequent play.

NPC and Monster Statistics

The inhabitants of an encounter area will be summarized within the DM text for the area. The statistics for these inhabitants are given in

paragraphs with all lines but the first indented from the left-hand side. The stats are presented in the same order in all cases, one after another and separated by semicolons. This order is given below, with the abbreviations used explained. Spells and special equipment are given below the stats.

DM Judging Text

This text is printed in standard paragraph format. The first paragraphs of an encounter area's judging text most often will provide general information about the area itself that is not readily apparent to the player characters.

The next paragraphs will explain the area's peculiarities. They could detail the reaction of the area's inhabitants to various party behaviors. Traps or tricks will be described in these paragraphs, and treasure will be detailed in the same way.

Inscriptions and Scrolls

In many of this adventure's encounter areas, there are phrases, sentences or verses written in "an ancient alphabet." These inscriptions and scrolls give the players hints about expected actions or solutions to puzzles. The writings are translated in text indented within the DM Judging Text. The original inscriptions are provided on the reverse of the DM's fold-up map.

Known Information And Rumors

Many times, an NPC will know information that will be valuable to the player characters. This information is given in the DM judging text as separate paragraphs indented on both sides.

Specific References

Whenever the judging text makes reference to other chapters or parts of this book, *italics* are used.

Inscriptions and Maps

A large, colored map sheet accompanies this book. On the front are four maps, three for players and one for the DM. It has several dotted lines that indicate where cuts should be made. Accompanying the colored mapsheet is a 16-page booklet with the maps from the adventure; these are for the DM.

Desert of Desolation Player Maps

In the text are indicated where the three player maps are to be given to players. If things go well, two of the player maps will be given to the players by Aman Al-Ra'iqub when they are in Bralizzar. One of these is of the south end of the Desert of Desolation, showing the location of the Oasis of the White Palm, Pazar, Terbakar, and the Gates of Sule. The other is a map of the pyramid and temple at Terbakar.

Then, if things go well again, the third player map will be given to the players in the Tem-

ple of Set. It shows the north end of the Desert of Desolation, including the city of Medinat Muskawoon and the Oracle Stones and Pillars of Martek. The central section of this old map, which purportedly was made by Martek, is gone.

Desert of Desolation DM Map

The long DM map of the desert (Map 6-1) is in the same scale as the two player maps. Thus, the player maps can be laid over the top of the DM map and they will fit. In a similar way, if you need to, you can lay a sheet of tracing paper over the top of the DM map and then transfer information to the player maps.

Furthermore, the diagram of the Palm Sign on the hand of the Princess Shadallah is also in scale with the DM and player maps, so the diagram can be traced and laid on top of the player map to show the exact position of Phoenix. This is important, because the location of Phoenix is not known to any NPCs, and it appears on no map the players or NPCs have access to.

Inscriptions

On the back of the DM map of the desert are listed all of the ancient inscriptions from the adventure, except for the Tome of Martek. You should photocopy these inscriptions and then cut them out to give to players when the inscription is found.

General Notes

Ability Checks

Occasionally, the DM judging text calls for dexterity, constitution, or charisma checks. When this occurs, have the affected player or players roll 1d20. If the roll is less than or equal to the statistic named, the check will be successful. Otherwise, the check was a failure. The effects of success and failure are explained in each case.

Cumulative Chances

At times, the DM judging text gives a "cumulative chance" that something occurs. This means that each time a roll is made, the chance becomes greater. For example: As long as a character sits under a palm tree, there is a 5% cumulative chance per turn that a coconut will fall on his head. Thus, there is a 5% chance of a coconut falling the first turn, a 10% chance the second turn, a 15% chance the third turn, and so on.

Magical Traps

Some areas within the tombs and crypts contain complex magical spells and traps. To make the game flow more smoothly, you should pay special attention to these areas before playing those sections.

Duplicated Encounter Areas

Certain encounter areas, both in the wilderness and in the tombs and crypts, are duplicates of other areas. Areas that are exactly alike usually have the same Map Number. There is only one text description to use for each of these areas.

Judging Mounted Travel

You will need to referee desert travel for the first 10 days of the adventure, and then at other times as the party travels between adventure areas. To do this, you will have to take into account the type of mount being used, the load carried, the amount of water being consumed, and the terrain being crossed. The consumption of water and the effects of dehydration are important enough topics that they have their own major section.

Types of Mounts Available

It will be assumed here that the player characters are mounted, either on double-humped (bactrian) camels, or on Durpari horses, a sort medium warhorse without the training. These mounts are available for purchase in Bralizzar, or they will be given to the party by the soldiers, should that happenstance occur.

Camel, bactrian: AC 7; MV 21"; HD 3; hp 3d8; #AT 1; D d4; AL N; SA spits.

Camels attack by biting and spitting. They are ill-tempered, and thus there is a 50% chance that they will spit at anyone trying to mount them. If the attack succeeds, there is a 25% chance that the rider will be blinded for d3 rounds. Once mounted, the camel will continue on without difficulty.

Movement rate is affected by encumbrance, as shown in the section on Encumbrance, Movement, and Mounts. A camel that has remained in one place for an hour is likely to lie down; the chance of this is 20% cumulative. A camel will refuse to rise 40% of the time, this chance diminishing by 5% per turn of coaxing.

Though it requires 1 ration of plants and 2 rations of water per day, a camel can travel without food or water for 1 week with no effect. It may travel a second week without food or water, but its carrying capacity will be halved. After 2 weeks without food or water, the camel *must* be fed and watered or its value as a mount deteriorates rapidly. The table below gives the reaction of a camel to disturbances.

Horse, Durpari: AC 7; MV 18"; HD 2 + 2; hp 2d8 + 2; #AT 3; D d6/d6/d3; AL N.

Movement rate is affected by encumbrance, as shown in the section on Encumbrance, Movement and Mounts. A horse carrying more than its normal load must be rested for at least 1 turn every 6 turns; to have the full benefit of this rest, the load must be completely removed and the horse must be fed $\frac{1}{2}$ ration and given $\frac{1}{2}$ ration of water. There is a 1% chance per 8 hours of travel through rugged or very rugged terrain that the horse will pull up lame.

A horse needs 4 rations of plants or grain and 4 rations of water per day. It may travel 2 days without food or water, or 3 days on reduced rations, but then it will be fatigued. Horses will react to outside stimulus as given in the table. Use the result for *Other* to represent reaction to sudden movement.

Reaction of Mounts

The mounts used by the player characters in this adventure will react to outside stimulus according to the following table, using the guidelines given on pages 92 and 93 of the *Wilderness Survival Guide*. The first number represents chance of detection on d12, the second,

the chance of becoming agitated, and the third, the chance of panic.

Normal terrain would be the Sandvoyagers Track or the dry riverbed of the River Athis. Rugged terrain would be the open desert, the blasted hills that border the desert, Northknife Pass, and the shifting sands. Very rugged terrain would be the high blasted hills. These are discussed further in the section Judging Large-Scale Movement.

A mount can carry its load and move normally for half a day (8 hours), with occasional rest every hour. It may be pushed beyond this limit, travelling continuously for half its current MV in hours, to a limit of 12 hours total, without adverse effects. Any further movement likely will fatigue the animal. For example, a Durpari horse loaded with 4000 gp can move for 8 hours at 18"; if pushed, it can travel another 4 hours (total 12 hours) at 18" with no ill effects. A bactrian camel loaded with 6000 gp can move for 8 hours at 6"; it can be pushed for another 3 hours (6 divided by 2) at 6". If a mount is pushed beyond its limit, there is a cumulative chance per hour that it will become fatigued. This is discussed in the subsection below.

Table 1: Reaction of Mounts

Mount	Fire	Weather	Noise	Odor	Other
Camel	6/9/11	6/10/12	6/11/12	4/10/12	6/10/12
Draft Horse	5/11/12	8/10/12	4/10/12	7/10/12	6/10/12

Encumbrance, Terrain, and Mounts

The normal and maximum loads for camels and horses are shown in the table below:

Loads For Beasts of Burden

Beast Type	Normal Load (gp)	Maximum Load (gp)
Camel, bactrian	4000	6000
Horse, Durpari	4000	6500

The amount of load determines how fast the mount can travel. The less the load, the faster the travel for any terrain type. This is shown by the table below.

Load and Terrain Effects on MV

Beast Type	Maximum Load (gp)	MV Depending On Terrain		
		Normal	Rugged	Very Rugged
Camel, bactrian	None	18 + 1d4	8 + 1d4	4
	4000	18	9	3
	4500	15	8	2
	5000	12	8	2
	5500	9	7	1
	6000	6	6	0
Horse, Durpari	None	18 + 1d4	8 + 1d4	7
	4000	18	9	6
	4500	16	8	5
	5000	14	8	5
	5500	12	7	4
	6000	10	7	4
	6500	8	6	3

Fatigue For Mounts

An animal can become fatigued if not given its ration of food and water or if pushed beyond its endurance limits.

Fatigue from Deprivation

If a Durpari horse is given no food or water for more than 2 days, or given reduced rations for more than 3 days, it will become fatigued. If a camel is given no food or water for more than 2 weeks it will become useless as a mount or beast of burden. When fatigued by deprivation, the mount must be fed and watered, and it must be allowed to rest 8 full hours, or it will remain fatigued.

Fatigue from Overexertion

Furthermore, there is a cumulative chance per hour that an animal will become fatigued if pushed beyond its limits. This chance depends on the terrain, as shown in the table below:

Terrain Effects on Fatigue

Terrain	Fatigue Chance
Northknife Pass	50% per hour
Sandvoyagers Track	25% per hour
Open Desert	35% per hour
Blasted Hills	35% per hour
Shifting Sands	50% per hour
Sinkholes	75% per hour
River Athis Riverbed	30% per hour

When fatigued by overexertion, an animal must be rested for 12 hours plus 2 hours for every hour it was pushed beyond its limits.

Fatigue Effects on Mounts

Movement for a fatigued animal is at half its MV for the terrain and encumbrance. It may move at its normal pace 1 round per turn, for a total of 1 turn in 10. It may not move at all if the full movement rate is less than 3".

In any case, there is a 20% cumulative chance per hour that a fatigued animal forced to continue to work or move will become exhausted. When exhausted, the mount will not move and may collapse (25% chance if unburdened, 50% chance with normal load, 75% chance with more than normal load).

An exhausted animal likely will die. There is a base 50% chance this will occur in 1d4 hours. If this does not occur, there is still a chance that it will die, based on its hp. For 8 hours, a roll 1d6-3 will indicate the number of hp the animal will suffer. If it loses all hp, it dies, but if, after 8 hours, it is still alive, it will regain 2 hp per hour. When at full hp, it is no longer exhausted, but it is still fatigued.

Judging Large-Scale Movement

It takes a human afoot, moving at a scale speed of 12", one hour to cross one mile of desert on the Sandvoyagers Track; at this speed, it will take 5 hours to traverse one desert hex on the DM map, which has a scale of 1 hex = 5 miles. All other movements should be adjusted to that scale. Given that movement rate and a normal load, an adventurer riding a camel or a Durpari horse, MV 18", can traverse one hex in 3-1/3 hours.

Off the Sandvoyagers Track is a different story. The only other normal terrain is the dry riverbed of the River Athis. All other open desert terrain is at least classified as difficult, with much of it being classified as rugged or very rugged. These classifications will have a great effect on how fast the PCs can travel, as shown by the table below. In the table below, the travel times are given for one hex of the terrains listed. It is assumed that the mounts are rested and fed and are not carrying any greater than a normal load. Adjust these travel times if this is not the case.

Travel Times Per Hex of Terrain

Type	Terrain	Travel Time
Normal	Sandvoyagers Track	3-1/3 hr
	River Athis Riverbed	4 hr
Difficult	Desert Dunes	6 hr
	Low Blasted Hills	6 hr
Rugged	Northknife Pass	8 hr
	Shifting Sands	8 hr
Very Rugged	High Blasted Hills	20 hr

Judging Water Consumption and Dehydration

Part of the play of this adventure involves the player characters struggling against a wilderness likely to be unfamiliar to them. Though this struggle will be a daily occurrence, it is best not to get bogged down in the particulars. If the player characters have planned well, they should have no trouble with dehydration; if they have been sent on their way by the soldiers, they will have to use care.

Daily Water Requirement

For the purposes of this adventure, use the rule of thumb that a ration of water is 1 gallon (50 gp encumbrance) per day while riding (light activity), and twice that afoot (heavy activity) during the day. If iron rations are carried instead of normal rations, add 1 gallon for every 4 carried to account for the water not gained

from the food itself.

Camels require 1 gallon per day and horses require 4 times that amount. If plants are not carried to feed the mounts, add 1 gallon for every 4 to the water needed, making up for that lost from the food.

Careful conservation, and travel at night will stretch 7-days' water ration to 10 days.

Dehydration

If the player characters or their mounts get less than their minimum ration of water per day, they eventually will become fatigued from dehydration. A player character can go without water for 2 days in the Desert of Desolation before adverse effects creep in. As indicated elsewhere, a camel may go without food or water for one week without penalty, and a second week at half carrying capacity. A horse, on the other hand, can only go 2 days without food or water, or 3 at reduced rations.

The rules for judging the effects of reduced water consumption may be found in the *Wilderness Survival Guide*, pages 50-53, 88-89. The effects on combat and other strength-related activities are given there.

Finding Water

Two tries at locating water may be made in each 24-hour period. Unless a character has proficiency in Desert Survival, the chances of finding water are not great; such proficiency doubles the chances given below.

Because of the curse laid on Amun-Re, there is no chance of finding water in the Desert of Desolation between The Dustwall and Terbakar. North of the pyramid to the Oasis of the White Palm, there is a 10% chance of finding water within 2d6 + 3 feet of the surface at the foot of a dune or in the rocky hills. From the Oasis of the White Palm north to Skysea, there is a 20% chance to find water at these same locations. There is no chance of finding water in the sinkhole areas.

Except for the occasional oases, there are no plants in this part of the desert.

Judging Sighting Distance

The Pyramid Tomb of Amun-Re may be seen from the pass through The Dustwall in the early morning, but not after the sun's heat has a chance to beat down on the desert. From the top of a dune or a rocky hill, the pyramid can be seen from 10 miles (2 hexes). The obelisks (tall stone monuments) can be seen from 5 miles (1 hex). The various ruins can be seen from 2-3 miles distant, or half a hex. Man-sized objects are recognizable for what they are at 500 yards. Large sandstorms can be seen for at least 30 miles (6 hexes), and dust devils (desert tornadoes) can be seen for 20 miles (4 hexes).

The pillars of smoke mentioned in the adventure can be seen from about 5 miles (1 hex) during the day, because of the wind, and for 20 miles (4 hexes) at dusk or dawn after the wind dies down.

At night on the desert, visibility is better than normal because the sand reflects available light better than other locations and there is little water in the air. To determine the distances from which fires can be seen, add 20% to the distances given in the *Wilderness Survival Guide*, pages 72-75.

During the heat of the day, these distances will be halved, and during a sandstorm, visibility may drop to 20 yards.

Determining Distances

Distances are difficult for any character not proficient in Desert Survival to determine in the desert. There is a 90% chance that the distance guessed by just looking will always appear to be 1/4 to 1/2 mile away, regardless of the actual distance involved. Pillars of smoke that are many miles away will seem to be right over the next dune.

Judging Ancient Inscriptions

The inscriptions in the ancient alphabet are reproduced on the back of the DM's fold-up map. It may be a pleasant experience for your players to figure these out. The inscriptions are written in English, but the symbols stand for sounds, not actual letters. Most of the symbols bear a close relationship to the English alphabet, with related vowel sounds getting related symbols. Once the players get the hang of it, they will have virtually a 100% chance, with work, to read any inscription.

Still, this task may prove to be boring to some players. In this case, use a straight 30% chance for the PCs to read any inscription in the ancient alphabet. Give every PC a chance. If the inscription cannot be read after the dice rolls have been completed, it cannot be. As an alternative, you could give each PC a base 30% chance, with that chance improving by 1% for each inscription translated correctly, and with the chance lessening by 1% for each one missed. In either case, it is recommended that, if the players choose to roll dice instead of solve the puzzle, the dice roll be accepted as final.

Judging the Rumor Mill

The constant trade across the desert has allowed information from many parts of the world to be available in this area. The follow-

ing is a list of rumors the party may have heard before they begin their trek or may hear as the adventure continues. As with all rumors, most of the rumor is true, with some, some, or most of it is false. The rumors are written with the false portion set in *italics*.

Roll d100 for each rumor and divide by 5. This will give the rumor number on the table below. Rumors should be told to the player concerned in secret and they should always be given orally and never in written form. The player may choose to share his rumor with the other members of the party or keep it to himself.

1. The greatest Pharaoh of ancient days was entombed in *Pazar*. The city was buried beneath the sands, and the wealth of the Pharaoh was buried with him. His wealth remains there still *with a curse on it*.
2. *A palace of gold and gems once glittered on the northern horizon. Many people saw its spires of gold, but no one has ventured in that direction because of the curses.*
3. There are tall crystal obelisks in the north with writing all over them that tell of great people and deeds, *but they are evil places where death awaits*. No one who has gone to study those stones has ever returned.
4. *Beyond the hills the world ends. There the sky is bottomless. Ships sail the clouds and their spectral crews attempt to bring the souls they capture to the ancient Cursed City of Stone.*
5. One of the greatest Pharaohs of the ancient days cursed his own land and set out to ruin it. Yet even after his death, his people worshiped him, for his power reached beyond his grave.
6. Some of the most fabulous treasure lost in the desert were the Great Stars, of great power and tremendous value, they have been lost for centuries.
7. The land that was rich was made poor, and the only way to make the desert bloom again is to release the greatest evil of all upon it. It is only through the confrontation of that evil can life be restored.
8. A mighty pyramid lies in the desert that is believed to be theft-proof. It is said that all who have tried to enter have left their bleached bones among the rocks of the desert.
9. Tales of the Pharaohs' evil are surpassed only by the tales of their wealth. Many wondrous items were buried in their tombs and untold wealth must surely be found there.
10. The legends tell of a *demon* who will be (has been) released *by the old gods*. He will take vengeance on the desert and the peoples who live there to *punish those who have turned away from the cruel gods*.
11. There is a black monolith in the oasis in which an ancient evil lurks.
12. The minstrels of the desert see all that happens, but they never tell all they know.
13. Warehouse manager is not a good trade in the desert. The manager of the Guildhall in the Oasis has been missing for weeks they say.
14. Beneath the large oasis in the desert lies a lost temple, buried by the shifting sands.
15. There are many new caravans in the desert, but they travel only at night. I guess that's to conserve on water.
16. *Identical twins always hate each other, especially if there is much to gain by being first.*
17. Crypts are usually haunted by evil things, and this is especially true of the crypt below the evil amphitheatre. Don't go there if you value your life
18. The gates to the desert curse all those who enter, *just to remind them that they are stepping into terrible ground*.
19. The Sandvoyagers are an honest guild who make it possible to cross the desert in safety. There are said to be other caravans of slaves. These travel by night and will not allow any strangers to come near them.
20. Even if a great evil is released into the desert, the salvation from that evil will be close at hand. The salvation of the desert lies not in those who are there but in adventurers from a far land who will come to save us all.

Chapter 3: Setting Up the Campaign

In order to set up the campaign, the party must be transported to the far southeast corner of the Forgotten Realms, to the land of Durpar. There, in on the northern border of that land, nestled in The Dustwall, the mountains that border the Desert of Desolation, is the town of Bralizzar. In Bralizzar, the PCs may learn all they can about the mission, which is to gain the Sphere of Power of Martek, the area's most eminent archmage, now dead 1000 years.

This chapter provides one method for getting the party to Bralizzar. You can devise others, including a trek overland, if you desire. The advantage of the method presented here is that the party can leave the area where they presently adventure, play through the entire campaign, and be returned to their starting point without needing to know any details about the intervening geography.

Expected Play

The party, while on a wilderness adventure, will be driven into a cave inhabited by a family of trolls. Finding combat impossible (or at least unlikely) to be concluded successfully, they venture deep into the cave. They find a pair of scrolls and a teleport device that will take them to Bralizzar, where the campaign will really begin.

Throughout the play of this encounter,

encourage any role-play that would normally be expected, such as tethering mounts, securing gear, gathering firewood, etc., even though these preparations will not have much to do with the outcome. This encounter is linear in nature; the PCs have little or no choice about what will happen to them (if they want to live), but this fact must not be thrust down the players' throats. At all times, make it seem that the PCs' actions completely determine their fate.

Troll Cave Encounter Areas

Refer to Map 3-1 when playing this encounter. The Troll Cave has two chambers separated by a narrow, twisting passage. The outer chamber is large and deep, with a mouth that drops steeply to a flattened place 15 feet below. The inner chamber is much smaller.

1. Seeking Shelter

The party is moving through a steep pass, possibly Groll Pass or somewhere similar, when this occurs. Read this description:

The way is rock-strewn and rough this high in the steep path. As darkness falls, you notice that a storm of monumental propor-

tions is brewing, and will strike before long. Shelter is needed, and soon!

A glance at the pass being climbed confirms that it would be very dangerous to remain here, for any substantial rain would turn the trail into a tumultuous torrent of water as it flows over the rocky ground. Thus, you reason, the only safe place is off the trail, up into the rocks themselves.

Before long, the party spots a cave above them. The way up to the cave is difficult, and it is impossible to bring mounts up to the mouth, though there is a place above the flood mark and 15 feet below the cave mouth where mounts and heavy gear can be left.

It is important that the PCs feel that the storm has driven them into the cave. It probably is best if it breaks before they actually reach the mouth, but after they spot it.

2. The Outer Chamber

The storm begins in earnest just as you enter the cave. Cold rain is driven by high winds into the cave mouth for 10 feet, soaking the area. The torrent breaks loose small rocks and mud above the cave mouth,

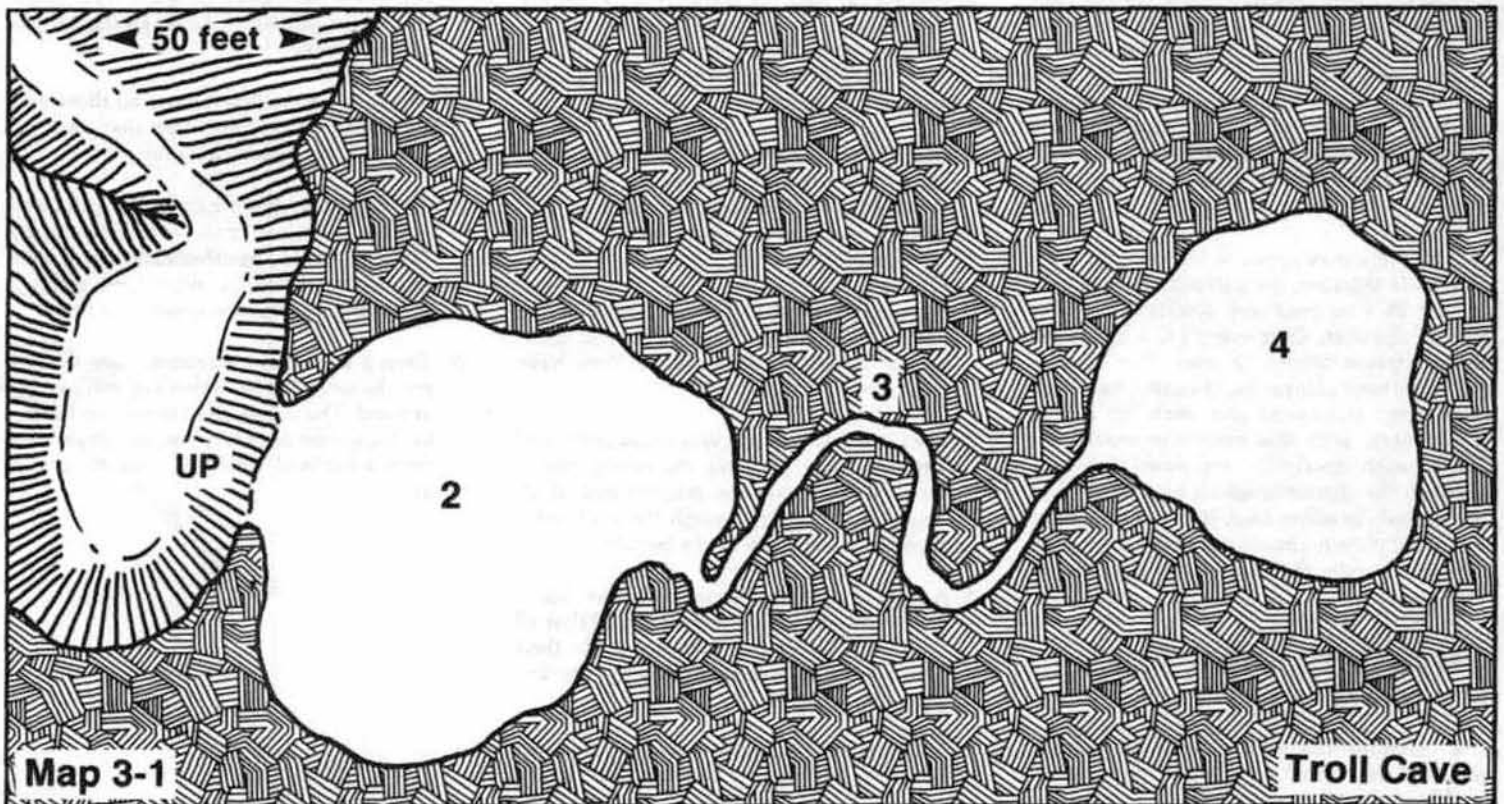

washing it quickly down to what has turned into a raging flood on the trail below.

Presently, the rain turns to sleet, covering the rock at the cave mouth with a rime of ice. It is lucky you found this place for travel outside is nearly impossible.

Any who would investigate the cave's rear will find that this chamber is large and deep, with a crack in the roof near the back and a twisting passageway leading deeper into the mountain. There is detritus strewn about the floor, including some rather large, gnawed bones. The mouth of the twisting passageway emits a very rank odor.

If the PCs have thought to gather firewood, they may get a fire burning. The smoke will drift to the rear of the cave and up through the crack in the cave roof.

Not long after the PCs have lighted a lamp or a fire, and before any can investigate the twisting passageway, they will hear a roar from below. It is the patriarch of the troll family that use the lower cave as a lair. He is alone, but the rest of the family is due back presently. He will leave the lair and make his way down the passageway to the entry chamber, where he will enter into melee with the three closest party members.

Troll: AC 4; MV 12"; HD 6+6; hp 49; #AT 3; D 1d4+4/1d4+4/2d6; AL CE; SA can attack 3 at once; SD regenerates.

3. Narrow Passage

The passageway is narrow and twisting, not really large enough to swing a weapon in. It is ripe with a very rank odor. It rises deeper into the mountain.

4. Family Room

At the end of the passageway is a chamber, smaller than the outer chamber. It is empty. Strewn everywhere on the floor are rags of cloth, bits of leather, saddles, and so forth. The mingled bones of a horse and a very large bird lie gnawed near one foul pallet.

Amid the detritus, the party can find a bone scroll case. Within it are two scrolls, one sealed and one not. There is also a small, oblong box.

The open scroll is a letter to Elminster the Sage, signed by his friend Aman Al-Raqib. It mentions that, at long last, his researches into the past have unraveled the mystery of Martek, who died 10 centuries or more ago. It says that his prophesy has merit, and, if the land is to be spared the devastation that awaits it, a party of heroes needs to set out very soon to recover his Sphere of Power. He is specific that

those who come must be brave, for the dangers are enormous and numerous, likely to bring death to any but the most cautious.

Eloquently Al-Raqib begs Elminster to send a group of brave souls to Bralizzar, that he (Al-Raqib) may beg them to undertake the quest. There is not much time for delay, for the Evil One will break his bonds very soon.

The letter concludes by stating that the box contains a teleportation device of Al-Raqib's making. It will bring any who would to him. The accompanying scroll details how to use the device.

The box contains 5 gold cubes, each marked with one magical symbol, the ones for air, earth, fire, water, and ice. The cubes feel as though they are alive, as they are warm and pulsing.

The sealed scroll directs the user to place the 5 cubes on the ground, symbols up, in the shape of a pentagram 2 feet broad. The cubes are to be arranged in the following order: air, earth, fire, water, ice. Those who wish to be transported should stand in the center of the pentagram.

When the cubes are placed as directed, they will begin to glow brightly. As each party member steps into the pentagram, a clear chime will sound, and the party member will disappear. If no party member steps into the pentagram after 5 seconds have passed, the cubes will begin to pulsate and dim for 5 more seconds, growing dimmer and dimmer with each pulse, until, 10 seconds after the last party member steps in, they disappear. It should be made very clear to the players that their time runs out rapidly, and that there is no time to fool around. When all who will step into the teleporter have done so, begin play with Special Encounter A, Chapter 4: *Bralizzar, Gateway to the Raurin*.

5. Return of the Natives

This will only occur if necessary to get the PCs to use the cubes and begin the adventure. Through the storm the remaining 10 family members may be seen approaching the cave mouth, or heard if no one is watching. Though the storm is violent and fierce, they pay no notice. They will be pleased to investigate any gear left below the cave mouth, and even more pleased to "investigate" any mounts left behind . . . at very close range their feeding sounds will be suitably repulsive.

Soon, one of the family will notice that someone is in the cave, alerting the others. All will make their way to the cave mouth, though some may linger to finish off any "investigation" that may be underway.

The family consists of Mom, Grandma and Grandpa, his three sons (nearly full grown), three adolescents and one youngster. They will leap to the cave mouth, but only four can enter at once, and so there will be some confusion as

to who goes first. The object is to give the PCs plenty of time to avoid conflict with the remaining trolls entirely, if they choose.

When no more delay can be justified, combat will begin. The trolls will fight to the death if necessary. Only one troll at a time can fit down the twisting passage, and this will serve as yet one more way to gain time for the party to use the teleport.

10 Trolls: AC 4; MV 12"; HD and hp as below; #AT 3; D as below; AL CE; SA can attack up to 3 at once; SD regenerate.

Troll	Hit Dice	Hit Points	Damage
Mom	6+6	47	1d4+4/ 1d4+4/2d6
Granny	4+4	35	1d4/1d4/2d4
Gramps	4	30	1d4/1d4/2d4
No. 1 Son	6+6	49	1d4+4/ 1d4+4/2d6
Teens	5+5	42,45	1d6/1d6/2d6
Adolescents	4+2	33,30,28	1d4/1d4/2d4
Youngster	3+3	17	1d4/1d4/1d4



Chapter 4: Bralizzar, Gateway to Raurin

Background

The town of Bralizzar is a caravansarai nestled in The Dustwall at the southern edge of the Desert of Desolation. The town began as a way-station for caravans headed north toward the busy cities of Pazar, Terbakar, and Phoenix along the River Athis. It was here that the caravans spent time before attempting Northknife Pass into the desert plain beyond and the perilous trek through the hills and dunes to Terbakar, from whence the River Athis sprang.

During the winter, many caravans would spend time here until Northknife Pass was cleared of snow, and it was through Bralizzar that first caravans from the north would come in the spring. It was the importance of the town that allowed it, with no other visible means of support, to become one of the jewels of the area.

All this changed with the curse of Amun-Re. The River Athis dried, the cities nearby were abandoned, and most of the caravans departed. A few intrepid adventurers passed through Bralizzar, headed toward the Desert of Desolation, but they were far between. Finally, all that was left were the abandoned temples of forgotten gods, and the Raurindi Dervishes.

The Raurindi, the remnants of the proud citizens of the once-fertile river valley to the north, came to Bralizzar. Seeing themselves as the guardians of the past and the hope of the future, the Raurindi took over care for the temples. Their religion, which accepted all religions as sacred, made them duty-bound to protect those places deemed holy. They settled in Bralizzar in the deserted homes of the rich and waited. They waited for centuries.

When the Sandvoyagers Guild reopened the trade route north, the Durpari merchants were not far behind. Now the town is their home, the Raurindi who once lived here either assimilated or pushed back out into the desert again to live as nomads. The Durpari cared nothing for the old religions, worshipping only their god Anu. The temples that once lined the major streets of Bralizzar fell into disrepair or were turned, like the Inn of the Golden Palm, to other uses. The wide streets became crowded with small shops and hovels except for the grand boulevard that leads from the still-proud administration building to the grand temple to the west. Only the boulevard retained its beauty, lined with the large residences of the wealthy and powerful and flanked by buildings that would make the cities of Zindalank or Seldazzar proud.

Since trade that exists by a thread can tolerate no interference, Bralizzar became a town of absolute law. A Lancer stronghold was created. Courts were also established, as well as inn and hostels for those who would travel into the desert.

To control the flow of merchandise to and

from the desert and to make it difficult for pillaged caravan booty to be transported, guardposts stand on the main trails that led to the Northknife and South Passes. Those entering the town from the north with a caravan are asked (forced) to show bona fides from the merchants of Phannaskul or Gheldaneth that they are legitimate traders. Those leaving town toward Northknife Pass are "asked" to show, in the same manner, a release from the Hetmann of Bralizzar to prove their right to cross the desert.

On the south side of Bralizzar, travelers are asked their business in town and issued a copper medallion as proof that they have entered town honestly. This medallion is to be retained by all visitors to Bralizzar as an affidavit of their transient status. Citizens of the town, those who have been before the Hetmann and have proved their ability to maintain themselves, are issued a silver medallion. This medallion need not be carried at all times, but it must be able to be produced on one-hour's notice.

Thus Bralizzar, a vigorous town of 500 permanent residents and twice that many transients, flourishes because the Durpari know that it is the last outpost before the arduous trek across the Raurin begins. It flourishes because its administrators know that to allow the laws to be relaxed for a moment would be to plunge the desert trade into the abyss of the past. It flourishes even though it has no sense of humor.

In every way, it is the Durpari who re-established Bralizzar as the gateway to the Deserts of Raurin. At first a flourishing city, next a ghost-town, then a desert waystation, now become a thriving town of modest size, Bralizzar reflects the Durpari.

Expected Play

Bralizzar is not as detailed as other adventure areas. Its purpose is to set the tone of the campaign, to provide a beginning point and a place to provision the party, and to give you a way to provide your players with some background information through the game setting. Play here can be as extensive as you desire, and you may flesh out the town as much as you like.

Most of the play here is likely to be role-play, as the PCs gather information and supplies. If the players are smart, they will exhaust every resource, keeping their noses clean, until they know whatever there is to know about the desert and their mission.

Providing Information To Players

In supplying specific information from knowledgeable NPCs (such as Aman Al-Raqib, Het-

mann Pasha Burak, or Lancer Captain Ashuk Masani), use the Background sections of the chapters in this book. Use this chapter to provide information about Bralizzar itself. Use the information in *Chapter 1: Background and Storyline* to provide information for the NPCs to give out on desert trade and the Sandvoyagers Guild and on the various legends surrounding the mission. For information about Pazar, Terbakar, the Oasis of the White Palm, Phoenix, and Medinat Muskawoon (now the Cursed City of Stone), see the Background sections in Chapters 7, 8, 9, 12, and 13. When rumors are the information supplied, use the General Rumors section of *Chapter 2: Judging Notes for the Dungeon Master* to provide them.

Be cautious in providing hard information. It is necessary to give the players *some* information to work with, but it is crucial not to give them too much. In no case will an NPC know any specific details, and the facts provided in the Background sections can be altered or changed to suit the whim of the DM. After all, much of what is recorded in those sections is 1000 years old, and time has a way of erasing details.

Player Maps

There are two player maps on the colored map sheet that should be given out during role-play in this adventure area. One of these player maps, Map 6-2, shows the south end of the Desert of Desolation. It is at the same scale as the DM map of the desert, and it shows the pyramid of Amun-Re, Pazar, the Oasis of the White Palm, the Gates of Sule, and the dry riverbed of the River Athis. This will give the players their first clues about where in the Desert of Desolation they should begin. Another of these player maps is a map of the temple and tomb of Amun-Re.

Unless play goes *very* badly, and the players are not at all cooperative, these maps should be given to the PCs by Aman. Failing that, they could be given to the PCs by Captain Murak after he escorts them to Northknife Pass.

Joining a Sandvoyagers Guild Caravan

There is a bit of a problem should the PCs decide the best thing for them would be to join a Sandvoyagers Caravan. From a gaming point of view, the best course of play is for the PCs to go it alone in the desert, with only their own skills and resources to help them face that dangerous trek. Unfortunately, with the presence of the Sandvoyagers Guild, this is likely to be a very poor second choice for them. Clearly the way for them to travel is as part of an official caravan. If it were not for the substantial amount of gaming opportunity that

would be lost, this would be ok. If you wish, you can make joining a Sandvoyagers caravan easy for them. You can also make it difficult.

You see, Jilida will allow people to join a caravan only upon the payment of a bribe. This bribe can be made small enough that the PCs can pay it out of petty cash. On the other hand, this bribe can be so outrageous that even the most excited party member will blench at the amount. Only you can gauge the effect this will have on play.

Crossing the desert to The Signpost will be no big deal if the party accompanies a Sandvoyagers Guild caravan. Because of the protection of the Airlancer guard, the caravan will have no trouble crossing Northknife Pass. Furthermore, as members of the caravan, the PCs have a right to expect a certain amount of service from the NPCs. This situation will cut down on play in the desert considerably.

Despite this, the ultimate goal, of course, is for the party to enter the desert on the quest for the Star Gems and the Sphere of Martek. If a large bribe will cause the PCs to turn away from this quest instead of working around it, then you should not take this course of action, even if allowing the party to join a caravan is required.

After all, the party will have to leave the caravan at The Signpost if they are to visit the Tomb of Amun-Re or Pazar. Furthermore, a wealth of role play might develop if the party decides to pay the bribe or otherwise deal with Al Jilida. They might beg, borrow, or steal the money, and the subsequent play might be worth the loss of play in other parts of this adventure.

If the PCs try to pay the bribe, you should make it hurt. Let it cut considerably into the party treasury. Better yet, make it so that the PCs have to raise the money somehow. They may have to borrow (or steal) the money from one of the several people who have it on hand. If they choose to steal, there is the possibility of a hue-and-cry and trouble from the Lancers. If they are caught, they will be sent into the desert as in Special Encounter B. If they have made friends with some of the important people, they may be lent the money or find a way to circumvent the outrageous demands.

If the party decides to brave the desert alone, so much the better. There are those in town who will give them help; it will be up to you and your players to discover who these folks are.

Major Non-Player Characters



Aman Al-Raqib, Astrologer and Advisor: AC 3; MV 12"; MU 15; hp 46; #AT 1; D 1d4; AL NC; S 9; I 17; W 9; Dex 12; Con 12; Ch 11. He has the following spells: *comprehend languages, detect magic, erase, identify, read magic; detect evil, detect invisibility, ESP, levitate, wizard lock; dispel magic, hold person, infravision, invisibility 10' radius, protection from evil 10' radius; charm monster, dimension door, remove curse, minor globe of invulnerability, wizard eye; conjure elemental, hold monster, passwall, telekinesis, teleport; enchant an item, guards and wards; Drawmij's instant summons.*

Aman Al-Raqib, originally from Thommar to the south of Bralizzar, is the close confidante and good friend of Hetmann Alham Pasha. He is a noted spellcaster in the Realms, conducting research into the life and prophesies of Martek, the southlands' most eminent mage. He is served by the mute giant Fuigarm.

Aman is the spellcaster into whose sitting room the party will be dumped unceremoniously by the teleport device they activated in the troll's cave, as described in Special Encounter A. Once he has recovered from the shock of their precipitous arrival, Aman will be gracious and grateful, doing what he can to persuade them to undertake the quest to locate the Star Gems of Martek and finally Martek's Sphere of Power. He will offer them lodging while they are in Bralizzar and will offer to help them in any way he can . . . except get home.

Aman is a wealth of information about the legends and lore about Bralizzar, the Desert of Desolation, Amun-Re, the Oasis of the White Palm, and Martek. He will be more than willing to share what he knows with the party, and there is a 60% chance that he will tell them any of the legends if they just allow him to talk. The section on Expected Play gives informa-

tion on what he is likely to know.

Aman will not, unless asked specifically, tell the party about the copper medallions that non-residents must wear while in Bralizzar. If the party decides to journey into the desert and tells Aman, he will relate that special passes are needed to get past the guard-post north of the city. He can and will arrange to have the passes issued.

If the party does not accept his quest, he will use his influence with Hetman Alham to have the PCs sent into the desert, as described in Special Encounter B.



Fuigarm, Bodyguard to Aman Al-Raqib: AC 9; MV 14"; F 10; hp 88; #AT 3/2; D 1d8+3; AL LG; strength bonus +2 to hit; +3 to damage; S 18/63; I 14; W 9; Dex 12; Con 16; Ch 9 (+3 for size). Fuigarm is armed with a scimitar +3, a dagger +2, and a silk shirt of protection +1 (AC 3 vs. missiles). He wears the silver medallion of a resident around his neck.

At 8'3" and 450 pounds, Fuigarm would be noticed in any society. Added to his size is a completely hairless head and ears that stick out from his head like giant fans. His eyes are so small as to be mere pin-points of light in his expressionless face. He never smiles.

Although stoic and silent, Fuigarm is far from stupid, and his little eyes see everything that goes on around him. He is a mute, but he communicates with his master Aman Al-Raqib through a complicated sign language that only they understand. He is fiercely loyal to Aman and will give up his life for his master. If the party has been particularly polite and respectful or if the PCs have volunteered to undertake Aman's mission, Aman will direct Fuigarm to protect the party while they are on the streets of Bralizzar. In doing this, Fuigarm will fulfill his duty even at the risk of his own life. When he accompanies the party on the street, most residents will keep a respectful distance, and the possibility of being pickpocketed is severely reduced.



Alham Pasha Burak, Hetmann of Bralizzar: AC 8; MV 9"; F 1; hp 15; #AT 1; D 1d4; AL NL; S 10; I 15; W 13; Dex 9; Con 12; Ch 14.

The ancient and venerable head man of Bralizzar, Alham is a less-than-adept fighter, his jeweled dagger (250 gp) being just for show. Because his word is law in Bralizzar, Alham Pasha is serious and should be taken seriously. He is respected and revered by all despite his age.

If the PCs seek him out, they will find him formal and reserved toward them as outsiders, though they can see that he is warm and sympathetic toward townspeople. Should the party be brought before him for judgment, they will find him to be absolutely fair and honorable in his dealings with them. Nevertheless, he will judge them according to the letter of the law, brooking no excuses nor heeding pleas of extenuating circumstances. Should the evidence be such that the party is in the right, he will find for them without a qualm, punishing the wrongdoers.

Hetmann Alham knows the following:

There have been rumors of fighting in the desert not far from the sacred palm. He hopes it is not the signal for an outbreak of war.

He has information that there are slavers operating in the desert, possibly under the guise of normal caravans.

The guard-post to the north requires a special pass before any caravan or party is allowed by. He can issue the pass if the PCs desire.

He knows almost everything about the history and background of Bralizzar, Trade through the Desert, and the Raurindi/Durpari Conflict, as given in *Background*.



Tekuna Chand, Female Innkeeper of the Golden Palm: AC 3; MV 14; A 7; hp 26; #AT 1; D 1d6 + 2; AL LN; S 13; I 12; W 16; Dex 18/77; Con 16; Ch 16. Tekuna is armed with a *stiletto* +3/+3. Her thieving abilities are:

Pick Pockets	45%
Open Locks	39%
Move Silently	85%
Hear Noise	83%
Climb Walls	91%

Tekuna, though approaching 50 years of age, is in excellent shape. She can still stand flat-footed on the floor and leap to the top of a table. Or, standing on a table, leap off the table, execute a double flip, and land, feet-first, on the floor. Her watchful eyes miss nothing.

Tekuna is a retired assassin who plies her former trade rarely, being content to operate the Inn of the Golden Palm in a friendly manner, accepting all who enter as men of good will. She serves fine wine and food to all who can pay her low rates, regardless of race, sex, religion, or political beliefs.

Tekuna is on good terms with all the permanent residents of the town. If there is trouble in her inn, and it is never from the permanent residents, she will quietly tell those involved to calm themselves. If that is not enough, she will call for the town guard, who will come quickly.

It is said that, after the miscreants have been fined and released, Tekuna will attempt to contact them and convince them of their poor judgment, with her stiletto, if necessary. It is widely said that it is not wise to be disrespectful to the little lady.

She will not befriend the party as a whole, but there is the possibility that a party member will become a friend. If this takes place, and the party member confides that the party is heading into the desert, Tekuna will impart the following about the Oasis of the White Palm:

The Sheik of the Oasis does not trust strangers until they prove themselves worthy. He has been known to accept gifts, however, but these should be expensive or magical.

The last caravan to come through the desert brought the news that the Sheik had finally arranged a marriage for his heir. The delay had to do with the appearance of some magical sign or omen.

The White Palm is sacred and under the protection of the Dervishes, who are excellent trackers and committed to *Bloodquest* should they discover any desecration of a holy place. Exercise caution and leave the tree strictly alone.

Happy Hogan Underwood is a halfling of substance. He runs the Desert Igloo in the Sandvoyagers Compound. Tekuna knows him personally, and may even give a token to the party member to carry to him.

There is an assassin working in the Oasis. His name is Zorath Blackblade. Beware of him.



Al Jilida, Assistant Guildmaster of the Sandvoyagers Guild: AC 5; MV 12"; T 4; hp 28; #AT 1; D 1d4 + 1; AL N; S 12; I 13; W 12; Dex 12; Con 14; Ch 9.

Al Jilida, a greedy, scheming, and utterly ruthless man, is in a position of real power, and he likes it that way. He is local head of the slaver ring that operates caravans masquerading as legitimate Sandvoyager caravans; he is in league with the slavers who now control the Guildhall at the Oasis of the White Palm. He no longer has need of his thieving abilities, being able to hire almost anything done from one of the slavers he commands.

Al Jilida also controls who and what enters the Desert of Desolation as part of a Sandvoyagers Guild caravan. This fact is important to the party, for without the protection and guidance of the Sandvoyagers Guild, their crossing the desert will be perilous indeed. Thus, if they wish to become part of an official caravan, they must deal with this man.



Ashuk Masani, Captain of the Durpari Lancers: AC 6; MV 12"; F 7; hp 55; #AT 1; D 1d8+3; Al LG; strength bonus +1 to hit, +2 to damage. He wears a *scimitar* +1, and a *sash of defense*, AC 6.

Ashuk dresses in the flowing, white bur-noose and scarlet cords of a Lancer officer. His status as an Airlancer is shown by the gold cords woven through the scarlet belt, and his rank as a captain is shown by the golden horn that hangs from his belt.

Ashuk is completely honest and very serious about his job of keeping the peace in Bralizzar and providing protection for the Sandvoyager caravans as far as the White Palm. Frequently found standing at the top of the steps of "The Raj," he is acutely aware of the activity in the town and bazaar below. He is an officer on the way up, and he intends to do the best job he can in this frontier posting that is so important to the merchants and rulers of Durpar. He commands the 15-Lancer, 15-Airlancer garrison here with an fair, iron hand.

Although Lancers are not supposed to judge any miscreant themselves, instead bringing them before the Hettman, Ashuk often elects to save steps by making decisions about offenders on his own. So scrupulously fair and honest is he that no one has yet complained, though it probably helps that his men are fanatically loyal. Although he will not befriend the party in any way, neither will he allow non-residents to be the butt of the many tricksters who frequent the town.

Special Encounters

Special Encounter A: Meeting the Wizard

This encounter will take place automatically when the party uses the teleport device they find in the Troll Cave (see *Chapter 3: Too Many Trolls* for further details).

For this encounter to have the desired effect, it is necessary to emphasize that the PCs are momentarily befuddled as they teleport into

the study of the wizard Aman Al-Raqib. Read the following:

You are befuddled and disoriented in a way scarcely felt before. Stepping into the pentacle bounded by the cubes brings a gut-wrenching feeling. First a flash of light, then intense black, both momentary, burst upon your mind.

Suddenly you find yourself in a room of strange architecture, gazing intently at the eyebrows and thinning hair of an aged man, a spellcaster by the look of his robes. Your back is pressed against something thankfully not solid enough to have caused you any pain when you materialized here. Your chest and legs are forcing the wizard to teeter on his stool.

His eyes fly wide as he sees you appear, and his mouth opens in surprise as he is bowled over onto the floor. Your balance upset, and your knees a bit unsteady as yet, you join him, nimbly avoiding crushing the frail old man beneath you.

A crash heralds the next member of your party, who has managed to upset the desk upon which the wizard had been writing. A tinkle of glass, and the rush of wind as your friend joins you on the floor, strike almost musical accompaniment to the inarticulate whoops made by the startled old man.

There is scarce time to think now, as the rest of the party joins you in this study, each one bowling over the one who preceded him. The old man displays surprising agility as he nimbly scrabbles away, avoiding the ever widening flood of adventurers deposited on his carpeted floor.

A chime sounds, and the five lead cubes that brought you here drop to the floor with a thunk. Stepping over and around the bodies arrayed on the floor about him, the old wizard scoops the cubes into a pouch produced from his belt, tweaks his moustachio, and waggles his flaring eyebrows, obviously with delight.

"My, my," he beams. "Welcome to Bralizzar, my heroes! So nice of you to drop in."

The old wizard is Aman Al-Raqib, detailed in the section on Major Non-Player Characters. He will act the gracious host, offering food and a place to rest. He will brush aside any attempts made by the party to explain how they happened to arrive here, preferring to believe (forcefully, too) that they are the heroes who will undertake the quest to find Martek's tomb.

Special Encounter B: The Bums' Rush

Should the party *not* volunteer to undertake the quest proposed by Aman Al-Raqib, or should the party fall afoul of Hetmann Alham

Pasha Burak, the following text should be used.

A lonely group of horsemen stands huddled at the foot of a pass through a range of craggy, dry mountains, the red light of a dawning day casting long shadows behind them. A strengthening breeze, carrying the night's chill, rustles their desert robes over their leather armor. The horsemen have formed a circle astride their steeds and hunch down sadly against the gusts.

It is your party that stands within the circle of grizzled soldiers. The last thing you recall is enjoying the richness of this land, to which you had been taken abruptly. You had been tempted by the exotic food, drink, and people, perhaps to excess while absorbing the strange tales of wealth and greatness. Now, however, you are awake, amid these heavily shadowed faces under a mountain sunrise.

The weathered face of the commander turns toward you, leather-brown skin setting off his steel-blue eyes. He pulls from his saddle pouch an elegant scroll and reads loudly over the rustling wind its flowing, formal message.

Know ye, by order of his Excellency, Alham Pasha Burak, Hetmann of Bralizzar and Trustee of Durpar,

Whereas it hath been reported of late to us that certain dark and vile desert raiders have crossed The Dustwall over long-forgotten paths, thence to raid and pillage our caravans and hamlets, and thence disappearing into those same forbidding mountains;

And, whereas our valiant Lancers have tracked these same vile creatures through the very teeth of that awesome range to the very borders of the most accursed land, know to the wise as the Desert of Desolation, and being knowledgeable as to the curses of that dead and haunted land did our host of brave Lancers wisely halt their pursuit;

And furthermore, whereas certain foreigners, whose descriptions match those of the very group here assembled at my request, were seen in the vicinity of the home of Aman Al-Raqib, wizard of the court, in the latter part of the evening;

And, whereas those persons did attain entry to said residence and did short-sheet the wizard's bed and do all manner of petty pranks and did leave for the wizard a certain maid for an alleged date with said wizard;

And, Whereas said wizard did

return to said residence with yet another wench, whereupon both the first and the second did begin a loud commotion and disturbance the like of which has never before shaken this stately court and upset the wizard to no end.

Therefore be it decreed that said persons be appointed special force under our eminence to track the course of the raiders from the Desert of Desolation, where surely even the raiders could not survive, to search out their hiding place, and to bring us back proof that they have found that hidden fortress in the desert.

We further decree that they may choose instead to undertake the quest proposed to them by said wizard, the most noble and wise Aman Al-Raqib, the details of such quest too numerous to mention at this time, but which being transcribed by that selfsame wizard will be retained among the records of this administration for all to see at some later date, such details not refraining from mention that the party here assembled may retain all that they bring forth with them for their own use from that fabled land of treasure and death whilst on the quest proposed by said wizard.

Be it further decreed that should these miscreants prefer neither of these quests, they may choose instead from death by hanging, death by fireball, death by polymorph, death by flamestrike, death by lightning . . .

Rolling the scroll back up with his calloused hands, the commander leans down toward you. "What this means, you poor foreigners, is that you have been chosen to enter the cursed dead land north of here. It means that it doesn't matter whether you were in the wizard's house that night or not, because you are easy to get rid of without ruffling any feathers."

"And it also means," speaks the aged, though rugged, Lancer beside the commander, "that these here raiders has caused the Hetmann a good deal of trouble with the Sheiks. You're his proof that he is doing something about them." His laugh rolls through the hills.

The commander silences him with a sharp look, then continues. "We have brought you certain supplies and mounts from which you may choose. After you crest the pass, there is little or no water

within two weeks' tortured ride. Furthermore, The Dustwall here is full of cutthroat barbarians that kill for the sheer joy of it. Without a heavily armed escort, it would be suicide to attempt passage through them. Your only hope, for what it may be worth, will be to follow this pass and whatever tracks you may find on the other side, and hope that they lead to water." His lifted arm points northward, and all eyes follow its direction upward into the forbidding mountains.

If the PCs leave Bralizzar by this means, the soldiers who escort the player characters to the desert will give them enough water for their party, including their pack animals, to travel in the desert for seven days. If they ration their water and travel only at night, their water will last for 10 days.

The pack animals available are camels and horses, and the PCs may choose their own mounts. The party will also be provided with three large tents with poles, each 10 feet by 20 feet in size, weighing 200 pounds. They will have 10 bundles of firewood, weighing 20 pounds each; one bundle provides fire for one night. Each member of the party will be provided with enough food for 2 weeks, and 20 gp in coin for expenses.

Bralizzar Encounter Areas

For play in Bralizzar, refer to Map 4-1 on page 17.

1. Temple of Anu

Under a tall dome, stands a three-tiered circular ziggurat of reddish yellow stone. From the lower level, a single flight of stairs rises to the upper circle and the high altar that crowns the summit. On each step of the pyramid is a wide band of carvings that depict innumerable intertwined dragons.

This temple was once the worship hall of a long-forgotten Raurindi religion. It was tended by the Dervishes until the Durpari forced them out. Now, reconsecrated to Anu, it is the only temple in the town where religious observances are held publicly. Because the Dervish religion dies hard and the Raurindi now mix with the Durpari, there are a number of residents who belong to a cult that worships the old ways. They hold religious ceremonies, but they are always at night and hidden from Durpari retribution.

2. Inn of the Golden Palm

A low building of brilliant white opens onto the street. Standing beside and in front of the building are tall palms, set in large stone tubs. Their branches arch over the door to form a shielded entrance. It is apparent, from its construction, that this was once a temple, but the sign hanging on the pillared front indicates that its function has changed. This is the Inn of the Golden Palm.

Within, the large common room is well-appointed and illuminated. It is gained by descending a flight of four stairs. At the far end of the room is a small stage, designed to hold musicians as well as dancers. The room smells faintly of incense and fresh, sun-dried linen.

Tekuna Chand is the proprietress of this inn. She is detailed in the section on Major Non-Player Characters. It is likely that the PCs will visit this place, and they may even elect to stay here, it being more comfortable than the home of Aman Al-Raqib.

3. Home of Aman Al-Raqib

A small two-story house of pale blue stone with a conical gold roof stands amidst flowering gardens. The windows in the house are oval, as though they were eyes looking out upon the garden. Surrounding the garden is a 14-foot-high wall of open brick tiles, which allows the street beyond to be seen. The gateway is onion-shaped, and the gate is formed of ornamental wrought iron.

It is in the study of this residence that the party finds itself after Special Encounter A at the start of play near the Desert of Desolation. It is likely that the PCs will use this place as a base. It is up to the DM to detail the interior if that becomes necessary.

4. The Raj

At the east end of the main street stands an impressive, four-floor, administrative building. It is constructed of white marble. The corners of the building are dominated by tall towers capped by minarets with onion-shaped domes. Wide stone stairs spiral up to a central porch from the sidewalks that flank the central boulevard. The main doors are bordered by intricate carvings in an ancient alphabet; they are cast bronze. The windows are covered by intricately carved stone screens.

Known as "The Raj," this four-story building houses the administrative offices (first floor,

Map 4-1 Town of Bralizzar

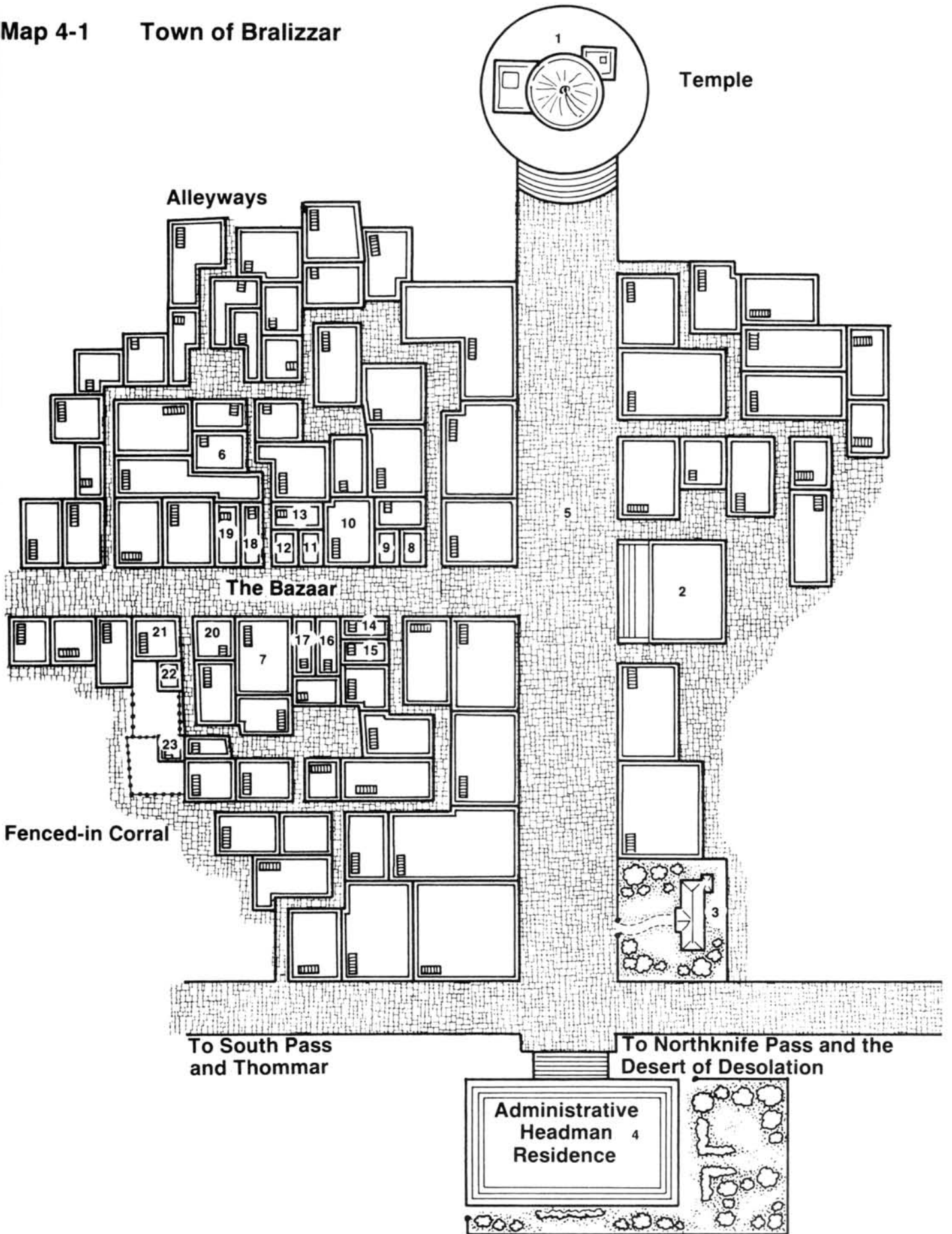

where the main entrance is) and home (top floor) of Alham Pasha Burak, Hetmann of Bralizzar, as well as the Sandvoyagers Guildhall (ground floor) and the barracks of the Durpari Lancer garrison. Besides the Hetmann, the only other permanent residents are the Durpari Lancers who occupy the entire third floor.

The garrison consists of 15 Lancers and 15 Airlancers; they serve as the local constabulary as well as the military patrol of the outlying area and the protection for the Sandvoyagers' Caravans from Bralizzar to the Oasis of the White Palm, where there is another garrison. They are honest to the core.

There are never more than 20 Lancers in town at any one moment, the others being on guard north and south of the town or flying patrols out into the desert. The average number is usually 10-15, and at least two of these will be on duty at the front desk. Their Captain, Ashuk Masani, lives with them; he may often be found surveying Bralizzar from the front porch of the building.

Durpari Lancers: AC 6; MV 12"; F 4; #AT 1; D 1d8+2; AL LG; strength bonus +1 to hit, +2 to damage.

Pegasi: AC 6; MV 24"/48"; HD 4; #AT 3; D 1d8/1d8/1-3; AL LN.

5. Main Boulevard

The town is dominated by a broad east-west road, paved with white marble. It is 60 feet wide and is bordered with sidewalks 12 feet wide. The roadway center is slightly higher than the edges, and there are 1-foot-tall curbs that separate the road from the sidewalks.

Along this boulevard lie the estates of the important villagers, if their size is any indication. Each is surrounded by a wall of decorative brickwork, a visual barrier more than a protective one. Behind the walls stand trees and shrubs, and the tinkle of fountains may be heard.

Between the estates, here and there run narrow alleys, connecting the boulevard to the less-magnificent structures of the city. Chief among these is the road centered on the south, which acts as the bazaar.

At the eastern end of the boulevard, the main routes out of Bralizzar may be found passing before the huge administrative building.

Several side streets and alleys lead off north and south of the main street, and these are filled with the less important shops as well as the homes of many of the residents. All but one of Bralizzar's many inns and watering holes are to be found along the side streets. Most of these are not detailed; if the DM chooses, he

may detail as much of the town as is necessary.

6. The Swayback Camel

A pockmarked, crumbling wall surrounds the inn called The Swayback Camel. Its presence is noticeable even were the sign not present because of the strong odor of stale beer and unwashed bodies.

Within, the room is low and dark, illumination provided by a few guttering oil lamps. It is so dark that the presence of others is felt, rather than seen, their shapes dim in the gloom.

Muthi Pashtral is the proprietor of this inn of less-than-worthy reputation. He is a slippery fellow, with a smile guaranteed to inspire distrust. His mannerisms are loathsome, his finger buried to the knuckle in his nose. Even to contemplate eating in his establishment would cause the most iron-clad stomach to turn.

But it is within his inn, amid the freelance camel drivers (mostly of evil dispositions and alignments) that congregate there, that some interesting information may be had. It is as follows:

It is rumored that a thriving business in slaves has sprung up in the desert. Operating under the most obvious cover, raiders are attacking caravans, imprisoning those who ride along, though you never hear of a guildmember being caught.

Muthi Pashtral, Innkeeper of the Swayback Camel: AC 5; MV 12"; F 3; hp 25; #AT 1; D 1d8; AL LN; S 11; I 12; W 9; Dex 12; Con 12; Ch 11.

7. The House of Mirth

Designed to look like any of the surrounding building entrances, the entrance to this place is narrow and innocuous. A small red tile is set beside the door marks the place, there being no sign.

Inside the structure is the main room, gained by several steps up from the street. The room is long and narrow, and doors give off of it to other areas. It is well-appointed with large cushions, small tables, and an elegant, if thread-bare, carpet. Illumination is provided by candles set in niches in the walls.

The proprietress is Tasha Lal, who is served by three ladies who can, at least, be classified as having passed "the sweet bloom of youth." Tasha Lal, a seemingly warm and comfortable woman of indeterminate years, is easy to talk to, which really helps her business at the House of Mirth. The House of Mirth is neither as callow as the Swayback Camel or as splendid as the Golden Palm, but it is an honest place where the meals are reasonable, and the weary

traveler is not likely to get a knife in the back.

Tasha Lal, Proprietress of the House of Mirth: AC 4; MV 12"; F 2; hp 15; #AT 1; D 1d4; AL NC; S 11; I 12; W 10; Dex 14; Con 12; Ch 17.

8-23. The Bazaar

This area has a collection of small shops flanking a rather wide street clogged with traffic. This is the bazaar, teeming with life and trade, for it is here that all the deals are made for bargains are made for the goods that will be carried across the desert. Each merchant is attempting to make the best deal possible for his merchandise; he is either a seller of goods that will be carried, or a buyer of what will return.

The customers shout at each other, waving their arms as they deal. But it is with subtle finger movements that the deals are made. As merchants clasp hands and haggle, the deals are made in secret. For those who watch, the holding of hands may seem less than manly, but it is the fingers that tell the tale.

You may use this area as required to further the adventure. Information about the city, including rumors about the Desert of Desolation, can be given out by the shopkeepers or, more likely, by the traders, for none of the shopkeepers have been to the desert, and all will give exaggerated prices for what they know.

Area	Proprietor	Wares
8	Dahna	Baskets
9	Abu Bahar	Harness
10	Adyat al Hayat	Cloth
11	Kurhur	Tents
12	Pasdophilas	Dried Meats
13	El Nahud	Nuts and Dates
14	Ban Fuka	Grain
15	Mitan	Trinkets
16	Torud	Rugs
17	Archimemilos	Statues
18	Wau el Kebir	Horse Trappings
19	Hochart Vestman	Silversmith
20	Que Nhon	Gems
21	Joachim Mullerschmidt	Blacksmith
22	Qatrun Medrusa	Camels
23	Aujilla	Horses

Chapter 5: Across Northknife Pass

Expected Play

This area is left relatively free of details, though you may choose to add any you see fit. It is a necessary bridge between the information gathering place of Bralizzar and the area of the main campaign in the Desert of Desolation. If you think that any of the random or planned encounters is more than the PCs can handle, tone them down. The point is to keep up interest, and give the feeling that the world is a real place, but not to blow away the party before they really begin the adventure. It should be challenging, but not so challenging that the PCs are significantly weakened before they hit the desert.

Northknife Pass Encounter Areas

For play in this area, refer to Map 5-1 on page 20.

Random Encounters

While the PCs are in this area, roll 1d6 every turn. On a roll of 1, there will be a random encounter. Roll 1d12 and consult the Northknife Pass Random Encounter Table below to determine the encounter's nature.

Northknife Pass Random Encounter Table

- 1d8 Bugbears: AC 5; MV 9"; HD 3+1; #AT 1; D 1d10; AL CE. Each member of this war-band is armed with a two-handed sword.
- 2-3. 2d6 Wolves: AC 7; MV 18"; HD 2+2; #AT 1; D 1d4+1. These beasts are ravenous.
4. 1-3 Yeti: AC 6; MV 15"; HD 4+4; #AT 2; D 1d6/1d6/2d8; AL ; SA paralysis; SD near-invisibility, immune to cold.
5. Travelers. This group is making its way down the pass from the summit. They are weary and bedraggled from crossing the Desert of Desolation on their way to Bralizzar from Mulhorand to the north. They will warn the PCs of the terrible desert conditions and such conditions in Northknife Pass as they have already encountered.
- 6-7. 1d4 Giant Mountain Goats: AC 7; MV 18"; HD 3+1; #AT 1; D 2d8; SA +4 damage while charging. They are making their way from the mountains to the right of the path to those on the left. They will be crossing the path when encountered.
8. 1d8 Worgs: AC 6; MV 18"; HD 4+4; #AT 1; D 2d4.

9. Hill Giant: AC 4; MV 15"; HD 10; hp 65; #AT 1; D 2d8; AL N; SA hurl rocks for 2d8 damage. This fellow is not unfriendly if approached correctly. He is clearing debris from the trail and the stream, keeping the pass open. He is in the employ of the Hetmann in Bralizzar.
10. Mountain Lion: AC 6; MV 15"; HD 3+1; hp 20; #AT 3; D 1-3/1-3/1d6; SA rear claws for 1d4/1d4. This beast will pounce on the end-most party member from a rock on the uphill side of the trail.
11. Grizzly: AC 6; MV 12"; HD 6+6; hp 44; #AT 3; D 1d8/1d8/1d12; SA hug for 2d8. You saw the movie; go for it.
12. 2d4 Mounted Bandits: AC 8; MV 16"; F 4; #AT 1; D 1d8; AL CE. These fellows will pose as travelers from the north, speaking very vaguely about their origin. When they have infiltrated the party so that each has a good target, they will attack. When reduced to half numbers they will break off and flee downhill.

1. Trail through the Pass

Rising abruptly from the wide valley within which Bralizzar lies, The Dustwall forms a formidable barrier. In the sunlight, the dead-grey rock is streaked occasionally by glistening red, as though the mountains had been wounded. The mountain tops disappear in writhing mists, and their feet are hidden by clouds of swirling dust.

Like a cleft carved by a gigantic axe, Northknife Pass cuts through this imposing barrier. From Bralizzar, the trail climbs slowly up the valley to the foot of this high pass before heading toward the mountains. When it begins its climb, it follows the course of a rushing stream that cascades from the heights above. In switchbacks criss-crossing the face of the mountains, the trail wends ever upward, seeking to scale the heights slowly enough to make travel possible. Passage through The Dustwall will be formidable, indeed.

The Dustwall (area 8) is a formidable mountain range, and Northknife Pass is one of the few ways through the range. The mountains are between 10,000 and 15,000 feet high here and are impassible except for the trail through the pass. They are snow-covered above 8000 feet.

Elevation of the path just before the ford is about 2000 feet above Bralizzar, and the top of the pass is another 7000 feet above. Movement rate on the path through the pass is half normal to the beginning of Giant Step Cleft (area 4) and one-fourth normal above that. At no time is the path easy to walk, and great care must be taken both afoot and mounted. There are times when it is so steep that movement must progress on foot, with the PCs leading their mounts.

2. Sweepaway Ford

The trail drops slightly as it approaches a swift stream that flows from the mountains. A ford lies ahead, and beyond it the



**Northknife Pass—
Map 5-1**

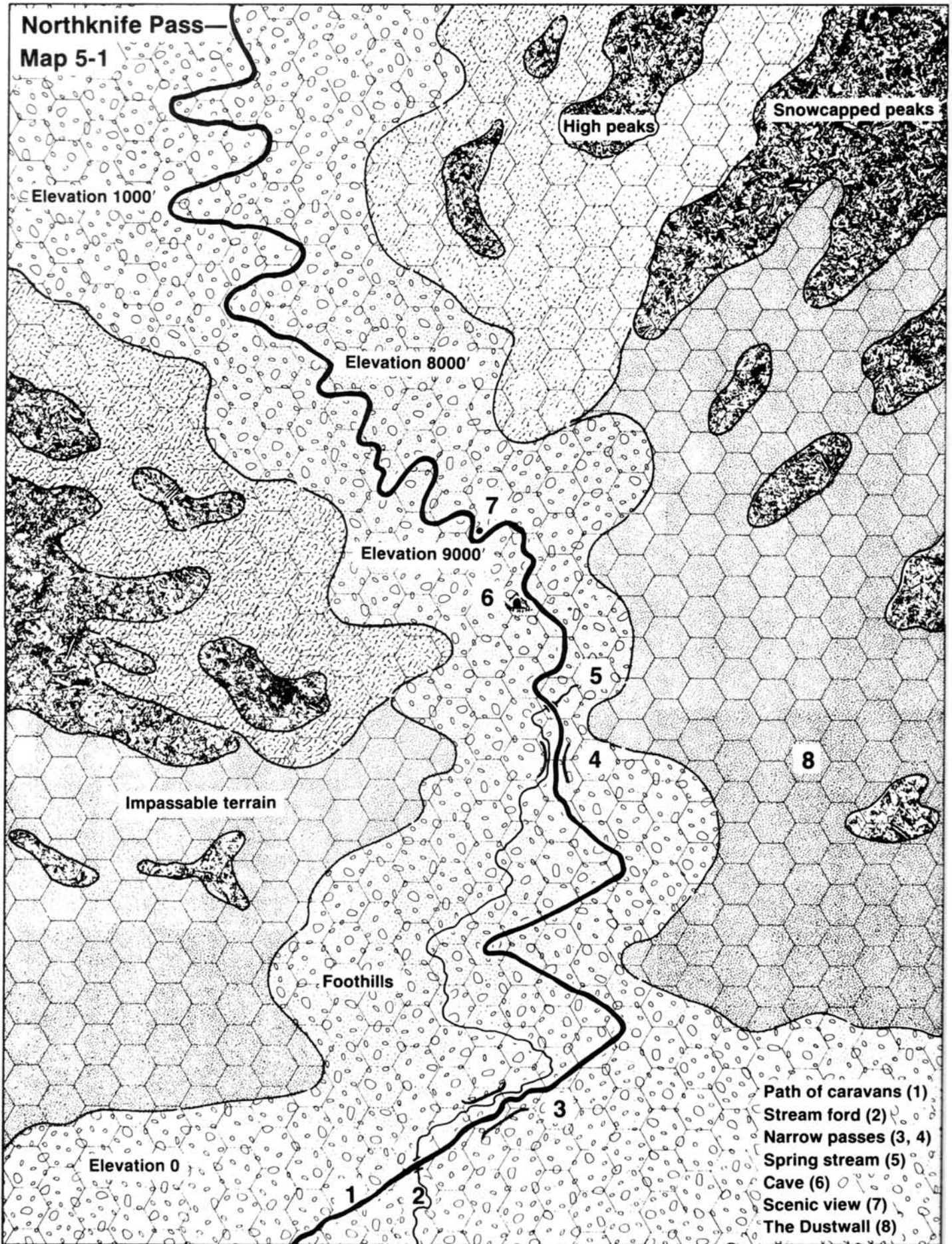

- Path of caravans (1)
- Stream ford (2)
- Narrow passes (3, 4)
- Spring stream (5)
- Cave (6)
- Scenic view (7)
- The Dustwall (8)

trail rises continuously into The Dustwall. The stream at the ford is 30 feet wide and obviously deep. A few rocks dot the surface, but they are wet, slime-covered stones, and they are far enough apart that only an unladen man of some dexterity and boldness would attempt to make the leap between them. At no other place up- or downstream does it appear possible to cross.

The stream is deep enough that the belly of a camel comes dangerously close to the foaming water. It will be impossible for a man to ford through the rushing water, though horses and camels may. Leapers crossing the rocks must make a Dexterity check at +3 or be dumped into the turbulence.

The water is icy cold, and it numbs the limbs immediately. Unless help reaches a fallen PC within 2 rounds, he will be swept beyond where any help will be possible. A man can last CON/3 rounds before becoming too battered and numb to save himself. It is possible to rescue oneself from the stream by making a successful Dexterity check and a successful Strength check. For each round in the water, modify the saving throws by -1.

Riderless mounts save at 15, and mounted camels and horses save at 14 or lose footing. A Dexterity check will be required for a foundering beast's rider to remain mounted and in control. If the save is successful, the beast gets another save at 14 to recover and finish the ford. If the save fails, the rider is pitched into the water.

3. Breakheart Cleft

A solid wall of rock 300 feet high crosses the way ahead, the only route being through a narrow gorge. The axe stroke that created Northknife Pass is carried down through the wall in a narrow gorge that climbs the 300-foot height in its quarter-mile length. To the left of the trail, winds a turbulent mountain stream. The trail is so narrow that single-file passage is required, probably afoot. This is a perfect place for an ambush.

There is an ambush here. Eight bandits have arrayed themselves along the northern wall of the gorge. When the party is safely in the gorge, two more will seal off the lower end. All are armed with bows, as their leader will point out from behind a convenient rock when the party is about mid-way through the gorge.

The bandits want food and easily spendable treasure. The leader demands the same (gauge the amount of each asked according to the supplies of the party), saying that the party should leave the "toll" on the path and continue on.

The bandits are some of the slimier residents of Bralizzar, and they are looking for some easy cash. They heard that the party was going to travel this way and preceeded them out of town. They are unwilling to show themselves unless it is absolutely necessary, preferring to intimidate the party into paying a "toll."

Thus, it is possible to negotiate with them. It is even possible for the party to tough it out with a show of force, but the force needs to be something that can reach the bandits 150 feet above the trail. Magic or missiles in sufficient numbers or with sufficient accuracy will do the trick.

If the party neither bluffs out the bandits or drops the "toll" (any sufficiently large package will do), the bandits on the ledge will open fire, and those in the gorge end will do the same if any PC comes within range.

10 Bandits: AC 5-8; MV 12"; F 2-5; #AT 1; D 1d6; AL CE.

4. Giant Step Cleft

As the trail begins to climb more steeply near the summit, it is once again blocked by a wall of rock, taller and more imposing than the first. The stream, smaller than before, forms the left-hand side of the cleft, and the trail, climbing steeply, hugs the opposite wall. A low moan, probably caused by the wind, throbs through the gorge. So steep and narrow is this cleft that steps have been carved in the rock to allow the climber safer footing.

Once in the gorge, it is nearly impossible to hear anything because of the reverberation of the wind's moan and the thunder of the tumultuous stream.

This is another likely spot for an ambush. If you like, you may add your favorite one here.

5. Resurrection Spring

Set 50 feet to the left of a tributary path, a spring bubbles forth amidst the rocks. The pool is irregular in shape, no more than 2 feet across, and the overflow pours down the mountain alongside the path. It is the source of the stream that has paralleled the trail to this elevation. The banks of the pool are a carpet of tiny purple and white flowers, graced occasionally by larger crimson blossoms and pure white lilies.

The water is so cold that it numbs the mouth and hands on contact. Animals will not drink from it without warming. This is the last water before Terbakar.

6. Refuge Cave

A circle of tethering posts stands near a side trail just below the summit of the pass. West of the trail, and 40 feet above in the face of the mountain, can be seen an opening. The cave entrance is so small that a man must bend low to enter.

Inside the cave is a room of sufficient size to hold a large party. The cave walls and floor show signs of frequent use, and a number of burnt-out torch stubs are scattered about. Although cold, the cave offers refuge from the howling, bitter winds that sweep the pass.

The cave has been used as a camp by most traveling parties. The problem is that the mounts need to be tethered below the camp, 100 feet down a steep, twisting path. Anyone trying to leap down the path to respond to a midnight alarm from the guard below must make two Dexterity checks two times or tumble down the path, taking 1d6 falling damage in the dark.

Of course, leaving the mounts with no guard is just asking for trouble; double the encounter chance, ignoring friendly encounters.

7. Height of Land Overlook

From this vantage point, and from none other on the trail below, there are no obstructions to sight north. At dawn and at dusk, when the sun is low, the reflection from the polished sides of the pyramid tomb of Amun-Re may be seen, flashing jewel-like in the golden desert below. The distant Hinjaz can barely be seen from here.

The path north of this point is much like the path up from the south, save that there is no stream valley here to make the way easier. Movement is at one-fourth normal all along the path until the foothills are reached. There is no free-standing water of any kind north of the height of land, and the snowline has climbed to 12000 feet. Some of the peaks have snow only on their southern sides.

Chapter 6: Desert of Desolation

Background

The Desert of Desolation was always a desert area, even before the curse of Amun-Re took hold 1000 years ago. It was possible, however, to traverse the area with relative ease along the banks of the River Athis, which flowed from the magical fountain at Terbakar. Many cities were built in the desert along its course; these now lie in ruins.

Expected Play

The judging notes for this area are extensive. They form a major part of *Chapter 2: Judging Notes for the Dungeon Master*. The DM map for this area, Map 6-1, is found on the colored map sheet. Two player maps can be found there as well, Map 6-2 of the south end of the desert from the Gates of Sule to the Oasis of the White Palm and Map 6-3 of the north end of the desert showing Skysea.

If you and your players are enjoying play in the desert, you may flesh it out by adding one or more ruins to explore. Along the dry riverbed near the Sandvoyager's Track can be found several ruins not detailed on Map 6-1. The gamemaster may add ruins wherever he desires, but these should be placed so that they do not interfere with the play from one detailed area of the campaign to the next.

It is expected that the players will break the curse of Amun-Re and set the Fountain of Athis flowing again. This will bring water to the desert once again. It will take some time for the water to percolate through the dry sands, but perhaps, by the end of the time taken for play in this campaign, the river will at least have made some headway as it flows north from Terbakar.

Desert Random Encounters

Because play in the desert will take quite a long time, it is likely that many random encounters will be rolled. The table for generating the encounter types is the most extensive in all the adventure areas for this reason. The type of encounter that is possible is strongly affected by the location of the party; the farther from habitation or the customary route taken by the desert peoples, the less likely they will be encountered and the more likely that any encounter will be with desert life or desert phenomena. The type of encounter is also strongly affected by the time of day, and so two encounter tables reflecting this have been provided.

Every 6 turns roll 1d6 to determine if an encounter occurs. During the daylight, from first light to dusk, an encounter will occur on a roll of 1; during the night, from dusk till first light, an encounter will occur on a roll of 1 or 2.

When an encounter occurs, determine how far

the PCs are from a human habitation, such as Terbakar or the Oasis of the White Palm, or from the Sandvoyager's Track. Count the number of hexes on the Desert Map 6-1 to the nearest habitation or to the Sandvoyager Track. Roll 1d12 and add the number of hexes. This will tell you what line to use on the appropriate Desert of Desolation Encounter Table below. Then roll 1d6 to find the right column on the table.

The result will be the encounter type. On the table, an *H* stands for a Human Encounter; this could be with Durpari, Raurindi, or other wanderers. A *P* stands for an encounter with Desert Phenomena, such as dust devils, sandstorms, mirages, or shooting stars. An *L* stands for an encounter with Desert Life, including monsters. And an *S* stands for a Special Encounter.

Desert of Desolation Day Encounter Table
Encounter with roll of 1 on 1d6

Modified 1d12 Roll	Column Number					
	1	2	3	4	5	6
1	H	H	H	H	H	D
2	H	H	H	H	H	D
3	H	H	H	H	L	D
4	H	H	H	L	L	D
5	H	H	H	L	L	D
6	H	L	L	L	D	S
7	H	L	L	L	D	D
8	H	L	L	L	D	D
9	H	L	L	D	D	S
10	H	L	L	D	D	S
11	L	L	L	D	D	S
12	H	L	L	D	D	D
13	H	L	L	D	D	D
14	H	L	L	D	D	D
15	H	L	D	D	D	S
16	L	L	D	D	D	S
17	L	L	D	D	D	S

Desert of Desolation Day Encounter Table
Encounter with roll of 1 or 2 on 1d6

Modified 1d12 Roll	Column Number					
	1	2	3	4	5	6
1	H	H	H	L	D	S
2	H	H	L	L	D	S
3	H	L	L	L	D	S
4	H	L	L	L	D	S
5	H	L	L	S	D	S
6	H	L	S	D	D	S
7	H	L	S	D	D	S
8	L	L	L	D	D	S
9	H	L	L	D	D	S
10	H	L	D	D	D	S
11	H	L	D	D	D	S
12	H	L	D	D	D	S
13	H	L	D	D	D	S
14	H	L	D	D	D	S
15	H	L	D	D	D	S
16	H	L	D	D	D	S
17	L	S	D	D	D	S

Human Encounter Descriptions

Choose from the list of encounter types below, or roll randomly. The most common encounters will be with the Durpari or the Raurindi Dervishes. The other wanderers should only be encountered within 30 miles of some habitation. Usually, once one of these encounters has occurred, it will not occur again, though there are some obvious exceptions, and similar encounters created by the DM could be substituted.

The Durpari

Roll 1d6 to determine which of the following encounters takes place:

- 10 Durpari Airlancers flying on Pegasi. Read the following description:

High overhead files a formation of robed humans mounted on pegasi. From the lance of one flutters a pennant of blue, with what appears to be a white circle comprising seven stars as a device.

The riders are flying in a V-formation of three 3-rider Vs, with the tenth rider well to the front as a scout. The Airlancers are currently looking for a lost caravan that cannot be delayed more than one day. They will land to investigate the party only if the party is alone during the day or camped with a fire at night, and then only on a roll of 1 on 1d6. If they land, read the following description:

Suddenly, a horn sounds. The white-robed riders tilt their lances downward and dive in your direction, their mounts landing so as to surround you. As they approach, still mounted, it is possible to see snow-white leather armor beneath their flowing robes, and a wickedly curved scimitar and metal-sheathed dagger hanging from the baldric of each. The casual way they bear their lances speaks of their willingness to do instant battle.

They will treat all strangers with suspicion until they prove themselves friends. They will not dismount, and, if the PCs do anything remotely hostile or surreptitious, they will bring their lances to the ready and prepare to attack.

Their spokesman carries the horn and pennant; no other badge of rank can be seen. He is polite, but very reserved, as he questions the PCs. He will listen to whatever

hey say, returning little or nothing unless the PCs show the Airlancers the medallion given them by the dying warrior on the Battle Plain (area 13) or the Sheik of the Oasis of the White Palm. If this occurs, the demeanor of the Airlancers will alter instantly, and their faces will be wreathed in smiles.

If the PCs withhold the medallion or do not have it yet, the Airlancers will leave the party alone unless the PCs have said or done anything that makes them suspicious. If this is the case (DM judgement), the patrol will return within 48 hours and have another "interview," this one with a completely different feeling. The PCs may end up being escorted to the Oasis of the White Palm or even back to Bralizzar, guarded by the Airlancers. If they resist, the Airlancers will attack.

Airlancers: AC 6, MV 12"; F 4; #AT 1; D 1d8+2; AL LN; strength bonus +1 to hit, +2 damage.

Airlancer Leader: AC 6, MV 12"; F 6; #AT 1; D 1d8+2; AL LN; strength bonus +1 to hit, +2 damage; magical scimitar, +1 hit, +1 damage.

Pegasi: AC 6; MV 24(M)/48"; HD 4; #AT 3; D 1d8/1d8/1d3; AL CG. They will obey only their original master.

2. Lost Caravan. The caravan consists of 20 camels and 25 Durpari traders. The traders are well-armed and 10 of them are fighters levels 3-6. This is the caravan that both the Airlancers and the Dervish scouting party have been searching for. They will ask the party for their general location with respect to the Oasis of the White Palm. Once this is given, the caravan will proceed there. The caravan will not go to any other location.

- 3-4. Desert Riders. Three Durpari riders gallop up to the party on their fine grey horses. They are traveling south in the desert, saw the party at a distance, and have come to investigate. Once they have been shown that the party is legitimate, they will ride away. They will not attack unless provoked, and they will offer the party no assistance, no matter what the situation or the offer of payment.

3 Riders: AC 7; MV 12"; F 3; #AT 1; D 1d8; AL LG; strength bonus +1 to damage.

Horses: AC 6; MV 24"; HD 4; #AT 3; D 1d8/1d8/1d3; AL LN.

- 5-6. Caravan. The caravan consists of 15 camels and 20 Durpari traders. The traders are

well-armed and 8 of them are fighters levels 2-5. They are traveling south and will tell the party their general location with respect to the Oasis of the White Palm if they ask. The caravan will not be diverted from its course.

Raurindi Dervishes

Roll 1d4 to determine which of the following encounters takes place.

1. Scouting Party. These dervishes are looking for a caravan reported wandering through this area, which was to provide much-needed food and supplies for their encampment. They will not give up the search but will, if their reaction is friendly, point the way to the nearest oasis. Each knows 1d4 rumors.

Dervish Scouts: AC 6; MV 12"; F 4; #AT 1; D 1-8+2; AL LN; strength bonus +1 to hit, +2 to damage.

2. Travelers. The party is made up of a very old man and woman, a middle-aged couple, and their two teen-age sons. The family will be wary of the party but will not run away if approached. They will share their water, even to the last drop. They know the location of hidden desert wells, but they will not give this information to the party under any but the most extraordinary circumstances.

3. 1d6+1 Hunters. These hunters are looking for desert animals. They will inquire if the party has seen packrats, snakes, or desert jackasses. If they are told where to locate them, the hunters will leave at once.

Dervish Hunters: AC 6; MV 12"; F 4; #AT 1; D 1-8+2; AL LN; strength bonus +1 to hit, +2 to damage.

4. Wounded Dervishes. All six members of the party are at half strength due to recent combat in which four of the party were killed. The party was sent out to avenge the recent looting of an ancient holy place by a party of adventurers. If the party is kind to these people, the Dervishes will tell them that they were able to track and kill a party of 12, recover the stolen artifacts, and return them to the holy place. They will not voluntarily tell the party where the holy place is located.

Dervish Hunters: AC 6; MV 12"; F 4; #AT 1; D 1-8+2; AL LN; strength bonus +1 to hit, +2 to damage.

Other Wanderers

Shepherd. This wandering individual, lost (in

the darkness), stumbles on the party. He is from the nearest habitation and knows its location and some rumors. The shepherd will not attack and will flee if confronted in a hostile manner. He may have a portion of his flock with him.

Goatherd. This wandering individual, lost (in the darkness), stumbles on the party. He is from the nearest habitation and knows its location and some rumors. The goatherd will not attack and will attempt to flee if attacked. He has lost his goats and will leave the party in search of them. He has no time for the party if they can't give him goat-specific information.

Dung Gatherer. This individual is wandering the desert in search of dried camel dung used as fuel. He has a large bag of the material with him which he will sell if the price is right. He lives in the desert and has no real use for habited places except as a location to sell his gatherings. He is very knowledgeable about the desert and its phenomena and can tell the party almost anything. What he does not know he will make up.

Desert Phenomena Encounter Descriptions

These encounters are daylight or night specific. The desert storms do not occur at night, nor do mirages, and the meteor showers, shooting stars, and frost similarly do not occur during the day. Use your judgment in determining if an event can re-occur.

Dust Devil

This is a daylight encounter only, usually occurring after the sun has had a chance to warm up the desert. It is the most dangerous natural desert phenomenon. Read the following description, and roll 1d6 to determine the course the dust devil takes from the choices that follow:

The air grows suddenly still. At a distance of five miles a column of yellow-grey sand begins to rise from the desert floor, climbing ever higher and assuming a funnel-shape.

1. The dust devil proceeds directly away from the party.

- 2-3. The dust devil moves toward the party and passes at 1-2 miles. Near the party, the air begins to move in small, random gusts, and small dust devils, no more than 2 feet high, swirl around causing no damage.

- 4-5. The dust devil moves toward the party and passes between 1/2-1 mile. Smaller dust

devils, 1d6+2 feet tall, spawned by the larger one will swirl around the party causing some damage. Objects not secured will fly off and be carried 1d10 x 10 yards in a random direction. There will be a 10% chance of blinding the party members for 1d6 rounds. Clothing will be tugged. Horses will attempt to face into the wind; camels will face away. As the direction of the wind changes, the animals will attempt to turn correctly, crashing into one another. There is a 10% chance that the animals will stampede. If both camels and horses are present, there is a 30% chance that they will stampede, and in opposite directions.

- The dust devil will move toward the party and over it. The dust devil moves at 30", so there is very little chance that the party can out-run or avoid it. The dust devil will do 5d4 damage points to a PC or mount lying on the ground, as the sand and rocks sweep by, swirling at 150 miles per hour. If it catches a character or mount upright, the dust devil will give 10d10 damage points.

The storm may sweep up the individual or beast and carry it for 4d4 miles before dropping it; the base chance for this is 30% for prone figures and 70% for standing figures, modified by -1 for each 10 lbs of the object. Falling from a dust devil will cause 5d10 points of damage.

It is clear that the best procedure would be to lie down and have they animals do the same; roping party members and beasts together will lessen the chance of being carried off by 10%. If the PCs huddle in between the animals, they will take only half damage.

Storm, The Shaitan

This is a daylight phenomenon, moving from west to east across the desert. It can be seen for at least one hour before it strikes, no matter where the PCs are, and so there is plenty of time to avoid the full effects. Roll 1d4 and consult the paragraphs that follow to determine the effects of the storm on the party.

- The storm, its huge clouds rising miles into the sky, passes too far away to have any effect on the party.
- The edge of the storm passes 1d4+1 miles from the party. The air will become cold, and a wind will blow away from the edge of the storm. Visibility will be reduced to less than a mile at ground level although the sky above will remain clear.
- The edge of the storm will pass 1d4 x 1/2 miles from the party. The air will become

cold, and a wind will blow away from the edge of the storm. Visibility will be reduced to 100 yards, party members will receive 1d4 points of damage from the blowing sand, and there is a 5% chance that each party member will be blinded for 1d6 rounds.

- The storm will pass over the party. Roll 1d6 to determine the type of storm: 1-2 Acid Rain, 3-6 Sand.

If the storm is acid rain, the rain will do 1d4 damage points per round to any exposed, living flesh. Cloth and other coverings shed the rain without damage. Animals must be sheltered from the rain either by cloth or overhanging cover. The storm will last for 1d10 rounds.

If the storm is sand, the swirling wind makes the establishment of direction impossible, and the party will be lost if they are moving when the storm hits. Visibility in the storm is 5 feet. The storm will last 1d6 turns.

Parties that are lost change the direction of their movement randomly. Movement rates in the storm decrease to 3" per turn. On a hex map, determine the location and original direction of movement. Then, roll 1d6 to indicate the hex side through which the party will move. Roll 2d6 to determine the number of rounds traveled before direction and travel time are checked again. For each turn, roll 1d6 to see if a random encounter occurs: 1-4 no additional encounter; 5 a sinkhole is encountered; 6 a dustdigger is encountered.

Mirage

This desert phenomenon occurs only during the day. Usually, the mirage will be seen to be some distance away in a random direction. When its apparent location is approached within 100 yards, the mirage disappears.

The length of time in the desert and the physical state of the party will make it more or less easy to spot a mirage for what it is. Each character may save vs. spells to recognize it, adding 1 to the dice roll for each 2 days spent in the desert, and subtracting 2 for each day without water.

Roll 1d6 to determine the type of mirage seen:

- Caravan. Many camels are seen at a distance of 2 miles. They are traveling in a random direction.
- Airlancers. Five Airlancers on pegasi are seen in the air 3 miles away. The Airlancers will fly toward the party and then disap-

pear when they get within 100 yards.

- Dust Devil. Determine the action of the dust devil as though it were real. If it approaches the party, it will disappear when it is within 100 yards. There will be no damaging effects from the mirage.
- Sandstorm. Determine the action of the storm as though it were real. If it approaches the party, it will disappear when it is within 100 yards. There will be no damaging effects from the mirage.
- Oasis. An oasis is seen in a random direction 5 miles away. The oasis will disappear whenever the party gets to within 100 yards of its apparent location.

Meteor Shower

The night sky is suddenly alive with streaming lights. Like giant fireflies, they streak from a position directly overhead toward the (insert direction desired) horizon. They act almost as an arrow to point where you should go... or perhaps should not go.

Shooting Star

The night sky is lightened to incredible brilliance by a giant fire that appears from the (insert direction here). The fire grows larger and larger as it streaks toward the (insert desired direction) horizon. The night sky is inky black after its passage.

Frost

This event can only occur after the desert sands cool sufficiently, usually late night. The chill of the desert night strikes into the bones. Any people unprotected by heavy clothing will take 1d4 of damage for every hour of the frost. The entire desert area becomes brilliant as crystal. In the morning, after the frost has passed, the desert will be alive with tiny flowers, painting the land in beautiful hues. Within a hour of daylight, the flowers have withered in the sun to leave the desert as barren as it ever was.

Desert Life Encounter Descriptions

The animals and monsters given below are the most prevalent life in the desert. The encounters described are examples of what could occur. The DM can substitute encounters of his own using these same creatures.

Animals

Wandering Camel. This camel has been dam-

aged which accounts for its reduced movement rate and lowered hp. The camel has been domesticated, but if loaded with any cargo it will refuse to move. If the camel is urged to move it will spit directly into the face of its tormentor, blinding him 50% of the time. This camel is an old and experienced desert traveler and knows the location of the nearest water. If left alone, it will take the shortest/safest possible route to the nearest oasis.

Camel: AC 7; MV 12" (of 21"; HD 3; hp 8 (of 3d8); #AT 1; D 1d4; AL N; SA Spit.

1d4 Giant Tarantulas: AC 6; MV 18" HD 2 + 2; #AT 1; D 1d4 + paralysis poison; AL N. Victims must save vs. poison or be paralyzed for 1d6 turns.

1d6 Desert Jackasses. The desert jackass is a vestige of the once-huge herds that roamed the fertile plain before the land turned to dust. They are curious little creatures who reach 30 inches tall at the shoulders upon maturity. They can be captured, and, with kindness and time, trained to carry loads. A full-grown jackass can carry 400 lbs. before its movement rate is diminished. Once domesticated, they think of themselves as members of the family and expect to be taken indoors if possible. They will also expect to share their master's sleeping quarters. These traits make the experienced desert traveler wary of becoming too friendly with the desert jackass. They will not attack unless provoked.

Desert Jackasses: AC 8; MV 14; HD 2; #AT 1; D 1d6; AL N.

2d6 Packrats. The group of packrats will emerge from the seemingly dead sand to scurry around the party. They will sit up and beg with shrill, scolding noises. They will not approach the party unless all its members remain very still. Then, the rats will creep forward and attempt to steal small items from the party members. They will run off and hide in their desert lairs. There will be no chance that they can be tracked further than the mouth of the lair for their burrows are very deep.

Packrats: AC 8; MV 9"; HD 1; #AT 1; D 1d4.

Kites. High overhead and at some distance, a single speck appears in the sky. As it is watched, other specks, appearing as if by magic, join the first. They are circling over some distant location. These are kites, the desert vultures, and they mark the spot of death. The DM must supply the appropri-

ate dead thing if the party chooses to investigate.

Tortoise. Lumbering along the desert is a giant tortoise, three feet in diameter across the shell. He moves so slowly that any normal human will have no difficulty reaching him. At first contact with a PC, the tortoise will withdraw into his shell for protection. The tortoise can be killed without difficulty. Then, the shell broken open, and the flesh eaten. The shell can be used, with some work, as a shield.

Gopher. A sharp, shrill chatter announces the presence of a desert gopher. It can be seen 30 yards away, its head emerging from a well-disguised hole. It will watch the party warily and disappear if they move toward it. It is impossible to dig him out as his burrow is extensive. The party can, with great patience, wait for his reappearance to try and capture him, but they would need to be desperate to do this.

Desert Monsters

10d10 Thunderherders. These monsters will begin to trumpet as they stampede. To determine the number of miles from the party that the trumpeting begins, roll 1d6-2. If the result is zero, they will begin to trumpet as they reach the party. If the result is -1, the Thunderherders will stampede by in silence. See the *Monster Manual II* for details.

Thunderherders: AC 3; MV 20"; HD 7; #AT nil; D nil; AL N; SA earthquake.

1d6 Dustdiggers: AC 4/7; MV 3"; HD 4; #AT 1; D 1d8 + AC of victim; AL N; SA enfolded victims cannot attack, illusion; SD burrows in sand as camouflage. See the *Monster Manual II* for details.

Purple Worm: AC 6; MV 9"; HD 15; hp 54; #AT 2; D 2d12/1d4 + poison; AL N; SA swallows victim.

Special Encounter Descriptions

Pool of Tefnut

From a distance, the party sees palm trees and shimmering water. The water and the palms do not disappear, but steady as they approach. The palms offer shade and comfort, the water is cool and quenching.

The first Good-aligned character that looks into the pool will see a pair of sultry, almond-shaped eyes in the ripples. A watery voice, like the lapping of the waves upon a distant shore will address the character and answer three yes/no questions for that character. The answers will be as truthful as it is possible for

the DM to answer. Only the person who is having the vision will be able to see the eyes and hear the voice. Upon completion of that vision, the entire oasis will disappear, leaving the party refreshed and the water bags full.

Sandmen

1d6 Sandmen attack the party at night. After the attack, roll again for an additional encounter that will occur. Affected party members will sleep through the encounter, with perhaps unpleasant effects.

Sandmen: AC 3; MV 9"; HD 4; #AT nil; D nil; AL NE; SA Sleep; SD Protection from normal missiles; MR 20%.

Spectral Traveler

Ahead of the party will appear a figure as though it rose from the very ground. The apparition is dressed in the elegant court attire of a Pharaoh. He stands, staring at the party, his hands on his hips. As the party approaches, he will raise his arm and point to the nearest place of current or past human habitation and then begin to walk in that direction. He will move fast enough to keep pace with a walking man. If he is approached by a mounted PC, he will allow the party member to reach 10 yards and then vanish.

Pillar of Smoke

A pillar of smoke will be seen against the distant sky. At first it appears to be only a cloud, but its vertical shape will show that it is actually rising from some location of human activity. The exact location of the pillar of smoke must be determined based on the nearest human activity and the visibility of the smoke.

If there is no regular human activity close enough to be seen, then the smoke came from a camel fry. If the PCs investigate they will find horse and human tracks. In the center of the area, a large, smoking mass lies on the sand, still warm from the heat of its dying flame. Bones of camels lie amid the charred remains. A trail will lead away to a direction chosen by the DM.

Aerial Battle

These encounters can only occur after the PCs have released both the efreet Khalitharius and the djinn Aeraldoth. It is likely that this will only take place when the party is north of Phoenix. Aeraldoth has been preparing for this fight for 1000 years, but he cannot win; neither can Khalitharius, who is angry that his vengeance must be postponed so he can deal with Aeraldoth.

The encounter should be set in such a way that the PCs cannot interfere, but they might choose to do so anyway. If this occurs, nothing the PCs do will visibly damage either the efreet or the djinn. In retaliation, the efreet will *flame*

strike the offending party member, doing 6d8 points of fire damage. If the djinn is attacked, he will purposely miss the PC with a lightning bolt the first time; subsequent attacks will do 1d6 x 24 damage points.

The Chase. Read the following description to the players:

You hear a noise like hissing steam from far away to the west. The noise seems to be moving to the north as it gets closer. There is something in the sky, like a red light, flying so fast you can hardly see it. Suddenly, from the west, a gust of wind whips past you, several hundred yards away. Sand flies up and fills your mouth and nose, stinging your eyes. Pieces of ice and drops of cold water blast down as you turn to

In a flash of bright orange flame, an efreet appears on the ground a few hundred yards away. A huge djinn appears before him an instant later. The djinn folds his arms and tosses his head, and the efreet roars in anger as he flings a huge fireball at his opponent. The burning ball of flame hits the djinn and flies past him, blasting a huge hole in the ground.

The djinn thunders laughter, pointing his right hand at the efreet. A black cloud appears in the sky over the efreet, who looks up in surprise. With a brilliant flash, a lightning bolt streaks down from the clouds. Just before it would have hit him, the efreet disappears in smoke. The lightning crashes into the ground sending debris flying in all directions. With another roar of laughter, the djinn vanishes.

and only the desert dunes remain. In this case, read the description for Desert Dunes (area 3).

2. Sandvoyager Guideposts

Wherever the track makes an unexpected turn, read this description.

Atop a dune near where the track makes an unexpected turn, a thin, tall pole marks the way. A wisp of colored cloth is attached to its top as a banner, and silvery bangles hang just below, reflecting brilliantly in the light when stirred by the breeze.

Each of the bangles is highly polished silver, treated with a spell to keep it from being dulled by wind-blown sand. The mark of the Sandvoyagers Guild is stamped in the center. Each contains silver worth only 3 sp, but as a guide post in the otherwise trackless desert, they



watch the winds fly by. Just for a second, you saw what looked like a giant man flying ahead of the wind storm.

As the sands start to settle, you hear an angry roar from behind you. From the western sky, a huge red, firey creature, shooting out long flames, chases after the wind storm. As this fire storm passes overhead, a wave of searing heat covers you. The ice melts and the cold water starts to steam. Fire falls from the sky, singeing your hair and landing on your skin like hundreds of redhot needles. As abruptly as the disturbance started, the whole thing is over. Both creatures disappear out of your sight.

Key to Desert Encounter Areas

1. Sandvoyagers Trail

Wending its way through the dunes in a northerly direction is the clear track used by such caravans as dare to cross these forbidden lands. Though the prints are far from distinct, it is clear that men, horses, and camels have passed this way. Some of these travelers seem, as you, to be penetrating ever deeper into the heart of the desert; others have been heading toward The Dustwall.

The track is easily followed by day or night as long as a sandstorm, generated with the Random Encounter Table or at the DM's whim, has not passed. If such *has* passed, then the track is gone,

have incalculable value.

If a sandstorm has passed recently, there is a 50% chance that the marker post is missing. If the track has been lost, and the PCs are within 10 miles of a post, the glittering bangles will act as a beacon, allowing them to return to the track.

3. Desert Dunes

Stretching to the limits of sight, the sand dunes of the desert roll into the distance, baked by the blazing sun. Not a single stone shows through the glittering grains, nor does a single insect scurry across its surface. In every direction, the burning silence of the sand-sea is oppressive and forbidding. The sun beats down like a golden hammer on this parched land, the crescent shapes of the dunes marching into infinity in all directions. Such landmarks as might be visible are hidden behind the shimmering desert air.

Melee. Read the following description to the players:

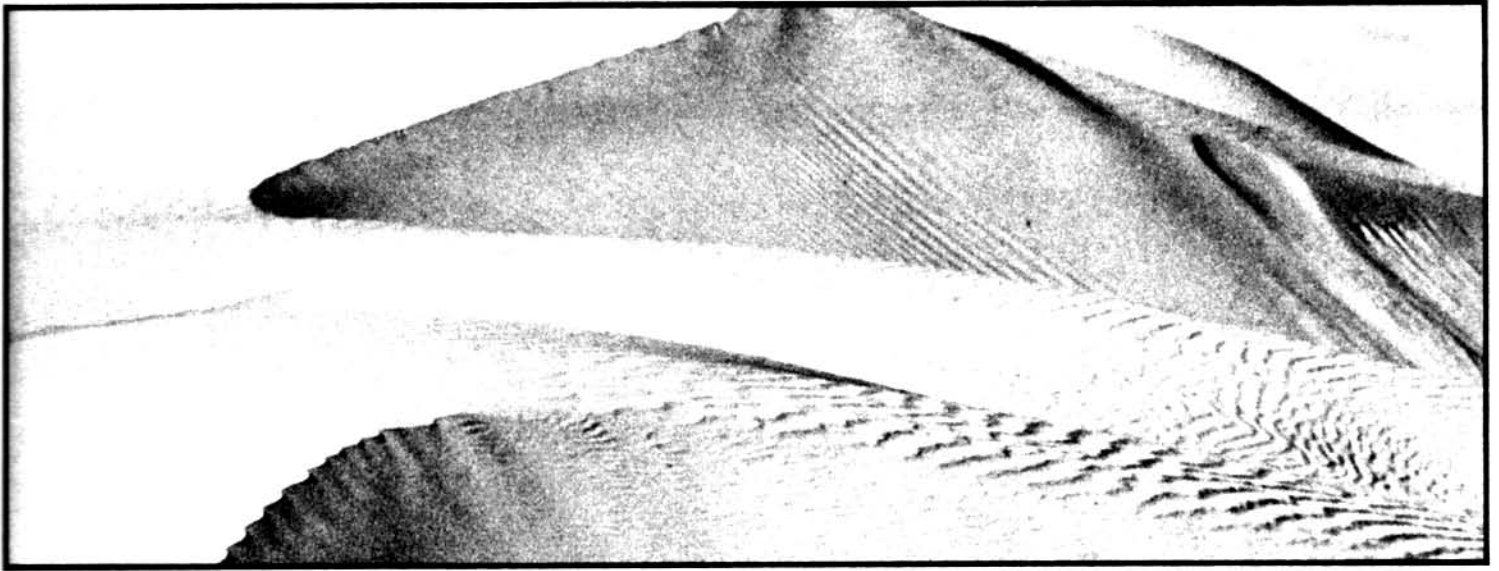

This description, or one like it, should be given to the players when the PCs have lost the Sandvoyager Track (area 1). It may also be given if the players ask what is visible from atop a dune looking away from the Sandvoyager Track. If the PCs are within 10 miles of a Sandvoyager Guidepost (area 2) and a sandstorm has not disturbed it, they may see the silver bangles glinting in the distance.

4. Blasted Hills

Craggy, low hills of broken and baked stone jut upwards at weird angles, casting tortured shadows across themselves. Even more oppressive than the sand dunes, if that can be possible, these areas of blasted rock show centuries of scouring by countless sandstorms. Higher than the desert

dunes, whatever water they conceal is evaporated at once. Only the shadows promise relief from the blazing sun.

Where the track skirts the hills, movement is easy; movement rate doubles in these areas. The track is well marked with Sandvoyager Guideposts. These are *not* shown on the map, because many would occur within the 5-mile hex. The Guideposts here are very well anchored, giving them only a 25% chance to be removed by a passing sandstorm.

It is possible to skirt the hills even where the track is not present, completely avoiding any shifting sands. On the large-scale map, assume that the hexes bordering the desert are of this nature. Passage here is difficult because the way around the dry washes, the impassible rock jumbles, and the dead-end canyons has not been scouted or marked. Because of the constant

detours, movement rates in the area skirting the hills are half those for normal desert travel.

Once away from the desert and deep into the hills, the terrain is even more rugged. On the large-scale map, assume that hexes not touching desert are like this. Passage here is *very* difficult because of the craggy cliffs, the hidden canyons, the steep talus piles. Movement rates here slow to one-fourth those of normal desert travel for all persons on foot except dwarves. They also slow for all mounts except donkeys and mules.

In the morning, the shadows cast on the western slopes provide brief respite from the sun, as do those on the eastern slopes in late afternoon. From mid-morning to late afternoon, however, the rocks are hot enough to burn the feet; eggs will fry on the areas of darker stone. In the deep hills (not in the hilly regions nearest the desert), there is a 60%



chance per hour spent searching of finding a cave large enough to shelter the party.

5. Shifting Sands

The sand in these areas is especially fine and shifts easily under the weight. Passage here is made difficult because the feet sink ankle deep (sometimes farther) into the fine grains. Though the movement rate will be the same, the passage is more fatiguing. If the fatigue rules are used from the *Wilderness Survival Guide*, judge this passage 25% more fatiguing than normal.

To most PCs, the Shifting Sands will seem different than normal desert dunes only 20% of the time. PCs with proficiency in *Desert Survival* have a 25% bonus, and rangers have a bonus of 5%. Those making a successful perception roll on percentile dice will notice the particularly fine grains and the difficulty with which movement is made.

through which one must wade. Unbidden, the thought surfaces that it would be better to remain still and let the sand cover you as it has done to everything else in this cursed area. Such rest cannot be, however, for there is much farther to travel.

Where the Sandvoyagers Track passes through areas of Shifting Sands, there are no Guideposts. The sand here simply will not support one. The Track follows the shortest distance between normal desert areas.

Any sandstorm in the area will disguise the track completely. It will disguise the Shifting Sands as well, mingling the fine grains with coarser ones at the surface. Perception rolls will be made at a -15% penalty.

sink. Camels will sink on a roll of 1 on 1d10, with horses and all other animals sinking on a roll of 1 on 1d6. Wagons sink on a roll of 1 or 2 on 1d6. If something is constructed to spread the weight out over a large area, adjust the saving throw accordingly; the reason for the high saving throw for camels compared to horses is due to the much larger hooves of the camels.

Complete submersion of a humanoid takes 1d6 rounds. Because struggling causes the sands to shift further, laying flat on the sand is a good way to slow sinking. Complete submersion for a horse takes 1d6+2 minutes, and complete submersion for a camel takes 1d6+4 minutes. The only way to keep these beasts from sinking is to throw a rope around them or find some other means of providing support; they will continue to thrash until they are completely submerged. Carts and wagons will sink to the level of the bed in 1d4 minutes, when the



It is easier for mounts to sense the change. Roll 1d12 for each; if the result is 9 or more, a horse will become skittish after entering the area, and if the result is 8 or more, a camel will show signs of distress. The mounts may be coaxed into passing through the area, but any other unusual occurrence at the time will add +2 to any reaction roll made. If the mounts react to the Shifting Sands, allow a second perception roll to determine the nature of the area.

Read the boxed description below if any PC has noticed the area is not the same as normal Desert Dunes.

Shifting sands pass underfoot, sliding aside with a whisper under the weight. Travel through the fine grains is difficult, sapping the strength and thus the will. Were it not for the heat, it would be possible to think of these dunes as immense drifts of powder snow,

6. Sinkholes

In the Shifting Sands, there are areas where the wind has blown the fine grains into valleys and crevasses, filling them to the level of the surrounding area and creating Sinkholes. This makes for treacherous passage, as it is possible to sink beneath the sand dunes here without a trace, particularly if one is not moving.

Each character, mount, or vehicle moving over the Shifting Sands must check to see if a Sinkhole is encountered. This check must be made once per hour while moving and once per turn while stationary in the Shifting Sands (area 5). Sinkholes cannot be spotted by most PCs. The base chance is 5%, rolled once per party. A party member with proficiency in *Desert Survival* adds a bonus of 10%. Mounts do not sense any difference.

If a Sinkhole is encountered, PCs and NPCs must make a Dexterity check in order not to

flat bed will halt further sinking.

Should rescue not occur, a submerged PC will take 1d4 damage points per round and suffocate entirely in 8 rounds. A sinking being will eventually become covered by 1d10+10 feet of sand; because of the very fine nature of the grains, excavation will be nearly impossible, as the sides of the hole simply collapse and fill in the excavated area.

A total of 20 strength points are needed to pull out small creatures (halflings, dwarves, small animals); 30 strength points are required to save medium (human-sized) creatures; and 80 strength points are needed to rescue large creatures. The strength of the player characters (but not pack animals) who are sinking may be applied to the total; for this to occur, the PC must make a successful Dexterity check at a penalty of -5 while still partly uncovered and a penalty of -10 if completely submerged.

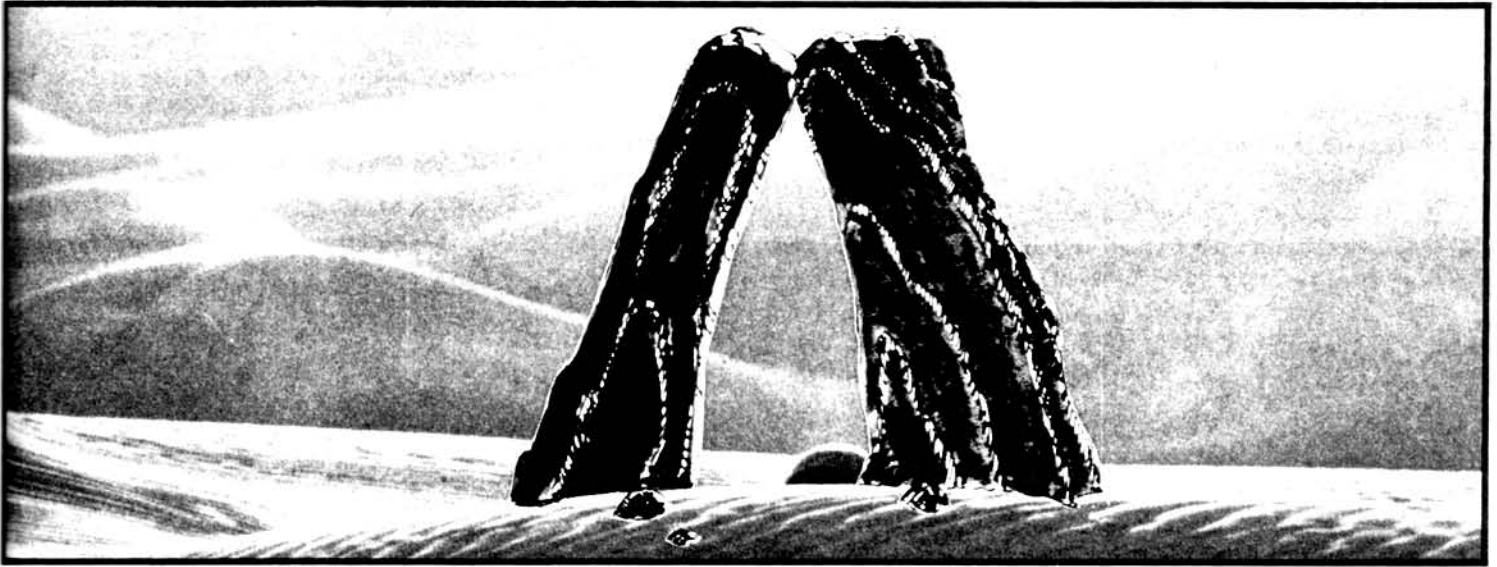

It will take $1d10 + 10$ minutes to extract anything or anyone. Note that those assisting in saving something will have to stop moving and must therefore check every turn to see if they sink as well.

Play test has shown that once the shifting sands begin to claim a beast or a PC, there is a very high chance that something will be lost forever. It is for this reason that the players should have accurate records of what is packed where, so that lost equipment may be removed from the party's inventory. Additionally, the DM should decide if the play will be severely hindered should such a tragedy occur. The shifting sands need not be deadly unless the DM so desires, for the dice only suggest probabilities.

7. The Gates of Sule

Rising up out of the dunes, twin pillars of stone flank the obvious track of previous desert visitors. These ancient pillars slant at odd angles, their peaked tops resting against one another, as though for mutual support. The pillar surfaces are pock-marked, eroded by centuries of sandstorms. Nevertheless, on the side of each facing you, an inscription is faintly visible.

It is obvious that the trail leads only between the pillars, and, if no storm has immediately preceded the party's arrival, the trail of horse and human footprints continues out of sight into the desert. Shifting Sands containing Sinkholes (see area 6) extend up to either side of the pillars, and any PC attempting to go around the pillars must enter them.

The inscriptions, written in the ancient alphabet of the area, are identical; they are reproduced on the reverse of the DM's fold-up map as Inscription 6A. They read:

The Gates of Sule Curse thee who enter unbidden.

8. The Signpost

Lying here in the sands, half buried, is a fallen obelisk (a four-side pillar), its top pointed toward the southwest. Carved runes are visible on its surface. The path taken by caravans and others is easy to spot. It veers neither right nor left, but appears to ignore the signpost completely.

Careful searching by someone with proficiency in *Desert Survival* or by a ranger will reveal the presence of trails branching off at this

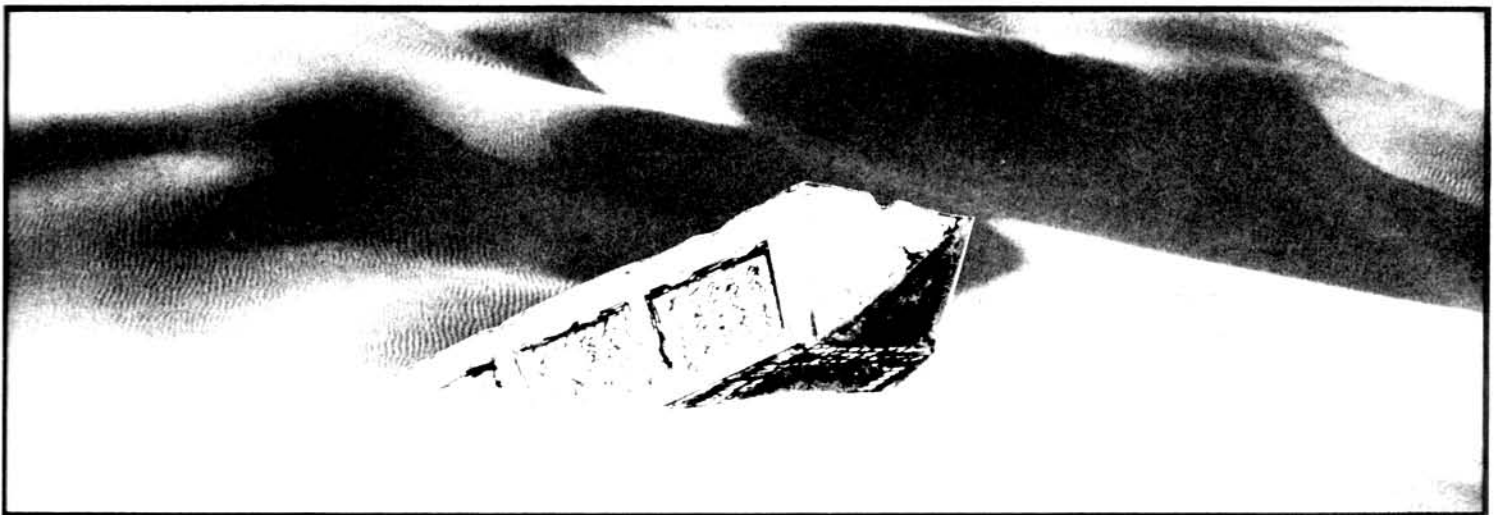

point, one to the right and one to the left. These trails disappear behind dunes after setting generally easterly and westerly directions of travel. These trails may be spotted by a ranger at half normal ability, with a bonus of 10% for skill in the desert. A recent sandstorm will cut the chance to find the trails in half once more.

There is no doubt, however, that the signpost indicates a trail once existed to the east (toward Pazar) and to the west (to the city of Terbakar, wherein were built the temple and pyramid of Amun-Re). The runes written in the ancient alphabet are reproduced as Inscription 6B on the reverse of the DM's fold-up map; they read as follows:

Here lies the road of the kings to the Garden City of Pazar, whilst there lies the road to Terbakar, Keeper of the Pyramid.

9. Land of Bakar

This area does not appear any different from the rest of the Desert of Desolation, but it is haunted by the ghost of Amun-Re, last Pharaoh of Bakar. For each hour that a party remains in this area, there is a 5% cumulative chance that they will encounter the ghost during that or the following night. When the encounter occurs, read the boxed description below.

Your skin blistered all day until the hot desert sun sank slowly below the horizon. Now, the deep blue mists of the night swirl over the sands of Raurin, the incomparable Desert of Dust.

As the cool night air drains the heat from the sand, you and your friends huddle around your campfire, glancing nervously about. An aura of eerie menace surrounds this place.

Gradually, the winds change direction, bearing a thin streak of white mist toward you from the west. It swirls and disappears behind a dune 100 yards away. Moments later, a solitary figure appears from behind that same dune, plodding through the cooling desert sand. He appears to be dressed in a leopard-skin robe and an ornate headpiece. He does not seem to be aware of your presence, yet he is heading directly toward you.

As a soul cursed by the gods, Amun-re cannot be harmed nor can he give harm to the party. Thus, he will not react to hostile moves, going so far as to be unresponsive even if a weapon passes through him. Likewise, he must not appear to be threatening, merely mysterious. Until he speaks and leaves no doubt about who and what he is, cloak him in as much mystery as possible, never saying directly that he is a ghost. Give hints, such as "he leaves no track in the desert sand" or "he seems to be strangely insubstantial, perhaps a trick of the moon-

light." Make the players *guess* at his nature with no confirmation from you.

The ghost will appear to take no notice of the party until they are within 15 yards, at which time he will turn and address the party directly, reciting his sad story. At this time, read the following boxed copy.

I am Amun-Re, son of Takosh-Re of the house of Mo-Pelar That which you see is but my shadow which has walked these lands for time uncounted, in search of mighty men of valor, to plead their aid.

In my time was I Pharaoh of this land now before you. Then, Bakar was a green and beautiful land, blessed by the gods of Heaven Westward with the wondrous spring of Athis, which gave life to our land and nurtured our crops. Yet did robbers raid the tombs of my forefathers and take from them tokens of their passage into the lands of the dead, thus keeping them from their reward after life. I swore that, at all costs, I would not fall prey to their evil deeds.

So it was that I made mighty and terrible war upon my neighbors, plundering their lands of wealth for my own passage. I did enter a contract with a great mage to work a mighty wonder, and, upon the sweat and blood of my people, I did build a theft-proof tomb.

My people turned against me with bitter hatred. I not only robbed our borderlands but taxed grievously my own people, and so took from them their wealth. They rose up in anger, demanding their gold and precious gems, their lives and freedom.

I cursed them, saying, "By the ruling staff and the Star Gem of Mo-Pelar, I curse you. Threaten not my life, or by them and by the holy name of Osiris, will the stopping of my heart also stop the Spring of Athis from her life-giving flow. As the river slows and dies, so shall your land wither in the wilderness. This do I swear by Osiris' holy name and these implements of my power."

From a sea of upraised fists before me, rose one with a spear. The shaft sped from the darkness, and so, too, that night did the Spring of Athis stop its flow.

In death, my spirit gleefully approached my pyramid. But Osiris stopped my spirit from entering that tomb, for, said he, "Your monument to life was to be the benefit you brought to the people under your stewardship, not this edifice of stone. As you looked only to your death in life, so shall you look only to your life in death. I am bound to fulfill your curse, for you have called it down with power in my name. But I do curse you as well, Amun-Re You shall not enter this tomb where the implements are of your voyage to heaven until some

mortal soul does despoil this place, taking your staff of ruling and the Star Gem of Mo-Pelar from your theft-proof tomb."

Even have I talked with the wind in hope of help. Uncounted seasons have passed, and my Kingdom is not now to be seen in these desert lands. Of it, nothing remains save for my tomb, which stands now as then, untouched by time, sands, wind, or men. Though many have tried to plunder my wealth, none has succeeded, and I am forbidden passage to heaven until one succeeds.

My wealth is thine if thou canst but best that which I have built. Remove both my staff of ruling and the Star Gem from my tomb. So then will you gain great wealth, and so then will you release me. Follow my path to wealth or woe, to thy destiny or thy doom.

The ghost of Amun-re will appear to the party every night thereafter that they are within the realm of Bakar and have not yet entered the temple and tomb. When the party is within sight of the pyramid, when he will appear and slowly raise his arm up to point towards the ancient tomb.

10. First Glimpse of Pazar

Read this description when the PCs are within 10 miles of Pazar. The statue described can be seen from the top of a dune.

Waist-deep in the desert sands, a stone giant stands guard over some aged ruins. Featureless from this distance, the statue appears to be clasping a tablet.

When the PCs approach closer, use the material in *Chapter 7: Sunken City of Pazar* and the corresponding inscriptions and maps.

11. First Glimpse of Terbakar and the Tomb of Amun-Re

From the top of any dune within 150 miles, and the top of any hill within 300 miles, the polished stone of the pyramid walls reflects the sunlight, allowing it to act as a landmark and a beacon even before its shape may be discerned. Within 50 miles, the 700-foot-tall pyramid takes shape, and when the party comes within 20 miles, it will be nearly continuously visible. From a dune-top 5 miles away, the ruins of Terbakar may be seen, along with the temple and pyramid of Amun-Re. Read the boxed description below.

In the midst of the vast desert sands stands the last relic of a dead civilization. From the broken foundations of a once-mighty city, a great pyramid rises, its polished stone walls gleaming in the sunlight like the facets

of a gigantic jewel. It is oriented with the compass points, a wall surrounding it. Before it on the south, a temple stands guard, the only break in the wall.

The pyramid and its temple are the only buildings that have escaped ruin. All the other buildings facing the broad boulevard that once led to the temple's stairs are gutted shells, filled with the drifting sands of the desert. Thin wisps of smoke rising from what appear to be pavilions near the temple steps announce that Terbakar, though a dead city, is not lifeless.

For further play in this area, refer to *Chapter 8: Tomb of Amun-Re*, and the corresponding inscriptions and maps.

12. The Hinjaz

Like the plated spine of a sea dragon rises out of the waves of a placid sea, so do the peaks ahead rise out of the desert dunes. Starkly forbidding they stand, black against the glittering sands.

The Hinjaz can be seen clearly from 150 miles away. They are not mountains in the usual sense, for they are not particularly tall. They are, however, taller than most of the hills within the desert, and they are impassible. Even if one had climbing skills to make passage through them easy, the killing temperatures during the daytime as the sun soaks into the black rock would make travel impossible.

Winds in the area pick up sand grains and scour the rocks constantly. In the daytime, these winds form towering updrafts over the mountains. Here, if nowhere else, may be seen the Air Lancers, circling their pegasi on the thermal updrafts to gain altitude. These flying warriors will be seen as dark specks in the otherwise flat sky, and their true nature may be disguised, depending on the distance. A sighting here may be used to bring color and a change of pace from the business of desert travel.

13. Battle Plain

When the PCs are within 2 miles of this area, which is on the Sandvoyagers Track, they will scent the odor of death, sweet on the desert breeze. This smell will grow stronger as they approach the battle area. When they are within 500 yards, read the boxed description below.

The dunes are stained with blood from a battle that must have raged here but a few hours ago. An army lies upon the churned-up ground, the sun baking their lifeless bodies and the remains of their mounts. All



is still save the soft rustle of the wind across the sand as it drifts over the dead. A single human figure, apparently the only survivor of the carnage, crawls slowly and painfully among the fallen bodies.

The surviving warrior, one of the Airlancers of the White Palm, is easily overtaken as he crawls toward the north. When the PCs are close enough to see him clearly, tell the players he wears the white robes seen on many of the bodies and is using the broken haft of a lance as a crutch.

It will be obvious to the PCs that the warrior is dying. In fact, no healing magic will save his life, for he must die to further the storyline. In judging this, each reasonable attempt to save him should seem to fail by a slim margin. The idea is to make the players feel that they have done everything within their power to save him, but his life had been claimed by the gods. If the PCs use up charged magic in the attempt, surreptitiously add an extra charge or provide them with magic to compensate their loss. This encounter is not meant to penalize the PCs in any way as long as they behave with compassion and mercy.

If treated kindly, the warrior will give the following account of what happened in the battle; read the boxed text below.

Gasping for breath, the dying man tells this tale:

Two days ago we and the Airlancers found the Oasis of Akhir, north of here, burned to rubble. We followed the trail of the attackers here, determined to have vengeance. No sooner had we arrived than over the western hills were seen clouds of dust and smoke. Suddenly, a tower of fire soared into the sky, taking the shape of a huge man.

"His voice shook the ground. 'Look upon the death of the world, ye mortals,' he roared from the clouds, 'for I have been released from bondage and have come for my revenge.' He raised his hand and the ground opened. Out poured his army of undead, and we were slain."

The warrior removes a medallion he is wearing and presses it into your hand. Then he gasps with his last breath:

"I beg of you, take this medallion of honor and show it to my Sheik Kassim. He is lord over the Oasis of the White Palm that lies to the north. Alas, the place is set. Tell him what happened to us and he will reward you. Only he can stop this evil now."

With this, he dies.

Choose the listener with the greatest charisma as the recipient of the medallion. It is a mithril disk, 4" in diameter. On one side it bears an enamelled device, a palm tree in stark white.

The bodies of the dead have been stripped of all coins, weapons, armor, and valuable items. The confused track of hooves and footprints is cut by a clear track of three ski runners that lead northwest. The bodies have been stripped by the slavers from the Oasis (area 14). The tracks are from their sleds, which have 3 runners; they may be followed to the Bleached Bones (area 14). If no recent sandstorm has obscured it, the Sandvoyagers Track leads northwards to the Oasis of Akhir (area 15).

Another trail of burned stone and gnawed bones leads toward the stone hills westward. This was left by Khalitharius, the efreet released from Pazar. The track heads directly toward the Crypt of Badr Al-Mosak (area 17); it disappears after a mile or so.

14. Bleached Bones

If the PCs are following the sled tracks from the Battle Plain (area 13), they will encounter this area. If they are not, it is unlikely that they will ever see this. Read the boxed description only if the PCs have left the Sandvoyagers Track and are following the track of the slavers' from the Oasis of the White Palm.

The trail suddenly broadens amid the dunes. The clean, white bones of camels stand in a roughly 100-foot circle. A set of three sled tracks leads northeast.

There is a 30% chance that a party member will discover that the bones have only recently been picked clean. All worthwhile objects have been taken from the area. The trail continues northeast to the Oasis of Akhir (area 15), where it rejoins the Sandvoyagers Track.

15. Oasis of Akhir

This area is on the Sandvoyagers Track, and is likely to be encountered if following that track or the track of the slavers' sleds from area 14.

What was once an oasis 400 yards across, now is burned black, the palms broken and charred. At one side tent poles, from which hang small scraps of singed cloth, jut from the sand. Nothing lives here now, though the water in the waterhole will insure that life returns. Several sets of parallel runner tracks head north.

There are no valuable items to be found, although there is evidence that the area has been disturbed since the burning. The path continues to the Oasis of the White Palm (area 16).

16. Airlancer Patrol Zone

When the PCs are within 10 miles of the Oasis, they will be met by a squad of Airlancers patrolling the area near the Oasis, looking not only for Dervish spies but also for servants of

the evil efreet Khalitharius. Read the boxed description following.

High overhead flies a formation of robed humans mounted on pegasi. From the lance of one flutters a pennant of blue, with what appears to be a white palm tree as a device.

Suddenly, a horn sounds. The white-robed riders tilt their lances downward and dive in your direction, their mounts landing so as to surround you. As they approach, still mounted, it is possible to see snow-white leather armor beneath their flowing robes, and a wickedly curved scimitar and metal-sheathed dagger hanging from the baldric of each. The casual way they bear their lances speaks of their willingness to do instant battle.

There will be 1d6+5 Airlancers in the patrol. They will treat all strangers with suspicion until they prove themselves friends. They will not dismount, and, if the PCs do anything remotely hostile or surreptitious, they will bring their lances to the ready and prepare to attack.

Their spokesman carries the horn and pennant; no other badge of rank can be seen. He is polite, but very reserved, as he questions the PCs. He will listen to whatever they say, returning little or nothing unless the PCs show the Airlancers the medallion given them by the dying warrior on the Battle Plain (area 13). If this occurs, the demeanor of the Airlancers will alter instantly, and their faces will be wreathed in smiles. If the PCs begin to tell the warrior's tale, the leader will say that the story is for the Sheik's ears first and halt the telling. He will detail two Airlancers to guide and accompany the PCs to the Sheik at the Oasis.

If the PCs withhold the medallion, the procession to the Oasis will have a completely different feeling. The PCs will be escorted to the Sheik, guarded by the Airlancers. If they resist, the Airlancers will attack.

Airlancers: AC 6, MV 12"; F 4; #AT 1; D 1d8+2; AL LN; strength bonus +1 to hit, +2 damage.

Airlancer Leader: AC 6, MV 12"; F 6; #AT 1; D 1d8+2; AL LN; strength bonus +1 to hit, +2 damage; magical *scimitar*, +1 hit, +1 damage.

Pegasi: AC 6; MV 24"/48"; HD 4; #AT 3; D 1d8/1d8/1d3; AL CG; they will obey only their original master.

17. First Glimpse of the Oasis of the White Palm

The presence of the oasis is first seen as dark specks in the brassy blue sky. Those seen from the greatest distance, perhaps 50 miles, will be the Airlancers of the White Palm. These may be distinguished at 10 miles, when larger birds can begin to be made out; furthermore, at this

distance, the silvery bangles characteristic of the Guideposts may be seen, as several of these hang from each tree. Within 5 miles, evidence of animal life may be seen on the Sandvoyagers Track, which is very well marked and heavily used. When the PCs are 2 miles away, read the boxed description following.

Oasis. The very name lightens the heart, adds spring to the step, gladdens the heart. The lush greens of the vegetation bespeak water, shade, cool rest.

On the edge of the oasis, a large nomad camp is pitched, perhaps as many as 100 tents and pavilions. People and mounts may be seen as well, and the smoke from cooking fires is borne away by the same breezes that rustle the leaves.

For further play in this area, refer to *Chapter 9: Oasis of the White Palm* and *Chapter 10: Temple of Set*, and the corresponding inscriptions and maps.

18. Path of the Malatath

Within any hex 250 miles or less from the Crypt of Bader Al-Mosak can be found evidence of the minions of Khalitharius, the efreet loosed from Pazar. Discovery of these devastated areas is meant to provide clues to the location of the crypt, and should be used to give relief from desert travel. The paths point straight toward the crypt; to any PC making a map, triangulation will pinpoint its location exactly. Read the boxed description when the first path is discovered.

In this area, burned bits of rubble and fused sand testify to some terrible destruction. Footprints, clawed and hooflike, mark the sands in a straight line into the distance, gnawed bones tossed to either side.

19. The Lands of Carthag

When the PCs come to the edge of the mountains ringing Phoenix, read the boxed description below.

Ahead, the ever-present dunes have subsided to mere waves in a vast sand sea. A low-lying bowl, at least 40 miles in diameter, bakes under the fierce desert sun. The superheated air is unrelieved by even a wisp of a breeze, and it hangs in shimmering curtains over the conical roofs and minarets that once were a great city.

For further play in the area, refer to *Chapter 12: Lost City of Phoenix*.

20. First Glimpse of the Crypt of Badr Al-Mosak

This crypt cannot be seen until the party is within 10 miles, when it may be glimpsed from atop one of the low hills in the area. From this distance, the circular amphitheater can be seen, with the toppled pillars like dark, broken lines radiating from a dark mass in the center.

When the party gets within 1 mile, read the boxed description.

In the midst of the rocky, low lying hills, a few broken pillars form a circle surrounding a terraced bowl. Toppled stone point at a statue centered in the bowl. An aura of menace emanates from the area, ebbing and flowing like waves on a shore. At its peak, the bowl and its statue seem to be physically oppressive, raising the hackles on the neck and sending shivers down the

The 30-foot-tall pillar has four faces that slope gently toward one another; they are oriented to the four compass points. On each face, ancient markings, worn nearly smooth by the blasts of wind and weather, are carved at the base, above and around a fist-sized hollow.

The carvings, in the ancient alphabet, are reproduced as Inscription 6C on the reverse of the DM's fold-up map, which translates as:

The Star is there, shrouded in curses,
hidden from sunlight by the Sun.

When a Star Gem is touched to the hollow, the Oracle stone will sunder at the base, falling unbroken to point at the Cursed Isle and the Star of Melos-Pelar in the ruins of Medinat Muska-woon. For further information, refer to *Chapter 13: Skysea and the Cursed City of Stone*.

In the distance to the north, to the limits of sight, the air shimmers strangely. The sand dunes flatten and look almost blue. Stranger still, the horizon has vanished, and the sky has become one with the desert.

At dawn, the entire sky is grey and dim. At dusk, you can see two suns in the purple and orange sky, one above the hot desert, the other below the dunes. As night falls, the two suns move closer and closer to each other. They become one and grow smaller and smaller, disappearing into the night.

For further play in this area, refer to *Chapter 13: Skysea and the Cursed City of Stone*, as well as the corresponding maps and inscriptions.

24. Isle of the Cursed

In the distance, barely seen through the shimmering air above the sea of glass, lies an



spine. Only when the feeling passes does it seem that the broken pillars, seeming like enormous, craggy fingers, might not crush intruders like clay between them.

For further play in this area, refer to *Chapter 11: Crypt of Badr Al-Mosak* and the corresponding inscriptions and maps.

21. Oracle Stone of Martek

Read the following description when the PCs have approached within 10 miles of the obelisk. Read the second description when they are within 150 feet.

A pillar of ancient stone stands silently over the desert sands. A lone finger, it stands sentinel among the sand and rocks of the desert.

22. Grounded Cloudskate

A strange metallic platform juts skyward, half-buried in the sands of the shoreline. A few feet away, a tall metal pole also pokes out of the sand. There is a crosspiece wrapped with bundles of woven bronze on the pole. The slanting platform has a pair of large gleaming blades mounted under it. There is a long thin blade hanging in the air on the side of the platform.

The buried object is a cloudskate, the skyship of legend. For further details, see *Chapter 13: Skysea and the Cursed City of Stone*.

23. First Glimpse of Skysea

When the PCs are 50 miles from the shores of Skysea, read the boxed description.

island, a black dot floating among the clouds.

For further details about this encounter area, refer to *Chapter 13: Skysea and the Cursed City of Stone*.

25. Cursed City of Stone

For descriptions and play in this area, refer to *Chapter 13: Skysea and the Cursed City of Stone* and the appropriate maps in the *Map Booklet*.

26. Pillar of Martek

A monument of three crystal spires rises straight and true from the desert sands. Monuments like this can be seen at various points about three miles in the distance.

For further play in this area, refer to *Chapter 14: Citadel of Martek*.

Notes

Notes

Chapter 7: The Sunken City of Pazar

The ruins of the Garden City of Pazar are the backdrop of play central to this adventure's storyline. After this dungeon has been completed, the storyline of the adventure will be well underway. Because of the events that likely will occur here, the players should have compelling reason to complete their quest—sense of responsibility toward cleaning up a mess that they (unwittingly) created. Furthermore, they should begin to feel a sense of urgency about their mission.

If play goes as expected, the player characters will fulfill the crucial part of Martek's prophecy in accidentally releasing an evil Efreet. In doing this, they may feel, as many heroes do, that they are caught up in something beyond their ability to completely control.

Background

The Sinking of Pazar

Pazar was constructed on a supremely lush island in the River Athis that flowed from the Fountain of Athis near the pyramid of Amun-Re to the west. Famed for its near-miraculous natural flowers and other decorative vegetation, it became a home for the priests of various religious groups whose worship included that of natural things.

As Pazar became more and more developed, the city fathers caused canals to be dug in the soft white rock that made up the island. This limestone was easy to cut and polish into glittering canals, fountains, and basins. Thus did the beauty of its bedrock become the Garden City's death knell.

Limestone is carved easily by water, which dissolves and wears it away. With the cutting of a vast canal system, the limestone bedrock beneath Pazar was opened to the erosive effects of the river, and whole blocks of the city began to sink.

While the waters of Athis still flowed in the valley, the city fathers paid vast sums to have spells laid yearly upon the foundations of their city, lest it disappear forever. When the waters stopped flowing, the lush gardens of Pazar died, the city became barren, and the spells were no longer kept up. The city sank into the vast holes carved by the river into its bedrock.

Kalif Maniozimus was the last of the city's administrators to leave. Before he, too, abandoned Pazar to the drifting sands, he caused a huge statue of himself to be erected on the tallest remaining rooftop, the dome of the temple of Eilish. This statue emerges still from the sand dunes that now cover Pazar.

The Imprisoning of Khalitharius

One thousand years ago, in a display of magical prowess seldom seen since, the archmage Martek bested and imprisoned Khalitharius,

one of the six Efreet Pashas and Viziers of the Fire Sultan. Each with his own dominion in the Plane of Fire, an Efreet Pasha has vast wealth and power there, rarely leaving except at the specific order of the Sultan of the Efreet.

Khalitharius made a grave error in judgment when he came rampaging onto the Prime Material Plane at this place, for it was under the protection of Martek, whose magical powers have remained legendary for the past millennium. Though he laid waste to a vast area, creating what is now known as Skysea, Khalitharius was not equal to Martek. With his Sphere of Power, Martek caused him to be imprisoned for 1000 years. That period is over now, and Khalitharius is to be freed very soon.

He sealed the efreet inside a lead box with powerful spells of binding. Over the entrance to this box, a small hole not unlike the wick-hole of an oil lamp, he set one of his Star Gems, a fist-sized black star sapphire that had the power to bind and seal.

He transported the enchanted prison to the Garden City of Pazar, secreting it in the Temple of Eilish. To prevent any but the most determined from releasing Khalitharius before the Efreet could free himself, Martek protected the magical prison with powerful magical guardians. These traps, along with the imprisoned efreet and the Star Gem, wait for discovery below the sands covering the sunken city of Pazar.

The Prophecy

Martek realized that his power over Khalitharius was only temporary, and set in motion events that would, 1000 years later, cause the efreet to be banished forever from the Prime Material Plane. He inscribed a prophecy that the Efreet would be freed and take his vengeance on the land. He also prophesied that a group of heroes would collect all five of his Star Gems, locate his tomb, and use his Sphere of Power to banish the efreet forever. With this latter prophecy, Martek actually arranged for the efreet to be freed by intentionally using the Star Gem in the magical bindings imprisoning him. When the "heroes" came to collect the Star Gem, they would release the efreet.

Martek was positive that Khalitharius would not return to his own dominion, but would stay and lay waste to the desert as he had been doing when Martek imprisoned him. This, reasoned Martek, would allow him to use all his power to confront the efreet once again and banish him forever from this plane.

Expected Play

The party is expected to investigate the Temple of Eilish, decode and best the magical guardian traps, and locate the Star Gem. They are expected to remove the huge black star sapphire from its place, breaking the seal, and

releasing Khalitharius. Doing all these things will fulfill Martek's prophecy.

Solving The Puzzle

The play in Pazar is problem-solving rather than role-play or power dungeoning. The key to the puzzle is deciphering the broken tablet found in the Scroll Room, area 9. The writings on this tablet are in the ancient alphabet, and a copy of them is provided on the reverse of the DM's fold-up map. Armed with the deciphered writings, the party will have no trouble whatsoever entering the Room of the Guardians and besting the magical traps.

Because play here is necessary to advance the storyline, there is little active danger here. Such real danger as exists will come from impatience and carelessness on the part of the party as they encounter with the magical traps in the Room of the Guardians, area 10.

If the players are solving the writings on their own, this will take some time. If some players get restless and begin to look for trouble, have their characters encounter some of the wandering monsters. Otherwise, let the players deciphering the alphabet do it in peace.

Wandering Monsters

To help the DM speed play, to give a necessary sense of danger, and to provide encounters for the players preferring hack-and-slash, there is an unlimited supply of tarantulas that can be used as wandering monsters. These should be easy to kill, and they are not meant to do more than to make the area *seem* dangerous. These monsters are discussed where they are first encountered, in area 4. Their lair (area 8) is not part of the play expected here, and should be made to seem too dangerous a place to be investigated.

Treasure

The only treasure of note is the Star of Agapelar, the fist-sized black star sapphire. It is one of the five Star Gems of Martek, and it will be required for the party to gain access to the Tomb of Martek. Any other treasure is incidental and unspectacular.

Urgent Adventuring

Like all adventuring, dungeoning takes time. Here, time can pass at whatever rate seems reasonable according to the player actions. It is reasonable to count actual time spent deciphering the writings as game time on a minute-for-minute basis. Searching for secret doors likely will occupy some time, as will the various scouting, mapping, and searching operations. Keep track of this time.

Remember that time passes *on the surface, too*. If the party has left their mounts on the surface, unprotected and uncared for, make as many random encounter rolls as would be required if the party were present. Judge this

fairly, remembering that play in this adventure area is required for the storyline. Do not penalize the players unnecessarily for having come here, but use this opportunity if it seems desirable to give them something else to think about before they hit the Oasis of the White Palm.

In particular, if the party does not leave immediately after freeing the Efreit, it would not be an unreasonable act to have him turn their mounts into a camel-fry. If they do leave immediately, however, this should not occur.

Key To The Sunken City of Pazar

For play in this area, use Map 7-1 and the appropriate inscriptions from page 39.

1. The Statue of Maniozimus

The upper half of a statue thrusts from the desert dunes. The noble face is pockmarked and scarred by the ravages of time and sand. The statue holds a tablet against its chest, half buried in the sand.

The PCs may uncover the tablet to read its message, which is provided on page 39. The tablet is completely covered with sand, which must be swept away from its face to allow the message to be read. This sweeping will require d6 rounds. The inscription reads:

My name is Maniozimus. Look upon the ruins of the great city that surrounds you and despair. Here, great magic once was. Now, you see only the mighty ruins of mens' works.

While anyone is in front of the statue, whether to uncover the message or to attempt to read it, there is a 5% cumulative chance per round and per person that the weight will cause a stone in the dome beneath to give way. This means that if 2 people stand in front of the statue, there is a 10% chance (2 people at 5% each) of a collapse in the first round, a 20% chance (2 people at 10% each) in the second round, etc. Judge this collapse using the information given below.

2. Sunken Dome of Eilish

If a collapse does occur, the sand will suddenly fall through, carrying with it whoever was in front of the statue at the time. Thereafter, the sands will stop flowing into the hole, and it may be approached safely by any PCs remaining above.

Those who fall through the hole will drop 30 feet onto steeply sloping, soft sand, taking 1-6 points of damage. They will then slide down the sand mound an additional 100 feet to the floor of the chamber an additional 70 feet below the hole.

In the faint natural light, you see a 100-foot-tall dome of fitted stone above a broken flagstone floor. The entire dome slants toward the southeast. Sifted dust and sand have spilled into the vast chamber where the dome has crumbled on the southeast side.

On the west, a darkly stained dome leans on top of a building that rises up majestically from the sand. Partially broken stairs lead up to its rubble-strewn front platform.

The players may see the pile as a way out of the dome, even though its top stands 30 feet below the hole through which the PCs entered. It is even possible that some of them may be on the pile when the first of the huge tarantulas is encountered on the temple porch to the west (area 4); if this occurs, melee will take place on the sand pile.

Climbing the sand pile unaided can be done only 40% of the time by most PCs; thieves can use their skill in climbing walls at a +10% bonus to their normal roll. Checks on climbing success are made three times: at the bottom, middle, and top of the pile. Those falling will slide back to the bottom of the pile.

Movement for PCs while climbing the pile is at $\frac{1}{4}$ normal for all except thieves, who are not affected. PCs caught in melee on the pile will have a penalty of -4 to hit.

3. Temple Portico

To the west, the base of the sand pile laps against three semi-circular stairs leading to an entry porch of a once-magnificent temple. Now, however, the platform is rubble-strewn, its leaning marble pillars supporting the domed roof. Centered in the porch's rear wall are two huge doors of stained bronze, partially open.

As soon as the first PC steps up onto the porch, a huge tarantula will squeeze out of the opened doorway and attack immediately. Four others will follow, engaging any other PCs that are near the porch, one tarantula per PC unless fewer than 5 PCs are present. If insufficient PCs are near the porch, the remaining tarantulas will scurry out onto the sand pile, unerringly seeking out any PCs that are beneath the dome. They will pursue fleeing intruders to the top of the sand pile. They are starving, which accounts for their low hit point scores. There is an unlimited supply of these in area 8, though only 5 will attack here.

Huge Tarantulas (5): AC 6; MV 18"; HD 2 + 2; hp 10,4,7,8,15; #AT 1; D 1-6 + paralysis poison; AL N; save vs. poison or be paralyzed for 2d6 turns. The sand pile does not affect their movement or combat.

4. Entry Chamber

The tilted floor of the dark, 20-foot-square entry chamber opens through archways to the right and left onto narrow, unlit passageways. Directly ahead, two golden doors, bright and shining, stand closed. Though the doors have neither handles nor fixtures, they are carved with strange writings. Dust covers the floor, and its smooth surface appears to have been untracked for countless years.

The doors are magically locked. They will not open unless a *knock* spell is used or the palms of a PC's hands wave before them and the player says "Sakhr al Jinni" (see area 9).

The strange writings on the door are disguised magically; they may only be read by a *read magic* spell. Then, the writing can be seen to be in the ancient alphabet of the area; what the PCs would see is given on page 39. They say:

Do not disturb the vanquished one. He is the treasure that must be kept.

5. Meditation Room

This 15-foot diameter room is entered through an archway. Untracked dust covers the floor.

7. Buried Entrance

The end of this 5-foot-wide, tilted corridor ends in a pile of sand. A small opening may be seen near the arched ceiling. At the far end on the left, a small, arched door is mostly covered by the sand pile.

The small opening is the end of a short tunnel that leads to the lair of the huge tarantulas (area 8). Any movement on the sand pile will bring one tarantula squeezing out of the opening. As it squeezes through, it can be meeled easily; give it a penalty of -4 to hit until it squeezes through completely (d4 rounds). If it manages to squeeze through, another will follow immediately, and so forth. If a tarantula can be killed while still in the hole, it will block the hole for d10 rounds. PCs fighting on this sand pile will be at -4 to hit.

The door opens toward the PCs and the sand blocking it must be removed before it may be opened to the Scroll Room (area 9). This will take d4 turns to accomplish. The sand cannot be removed without bringing tarantulas to investigate unless the hole can be blocked.

8. The Tarantulas' Lair

Beyond the sand pile is a large room, teeming with huge tarantulas... many more than can be counted. Nests and eggs indicate that this is the breeding ground for these poisonous creatures.

Assume that there is an endless supply of tarantulas here. All are starving, and all will attack without regard for their own safety. It is not intended that the party melee these creatures, and every attempt should be made to discourage the players from venturing into this area.

The tarantulas are meant to be a source of random encounters to help speed play along and to give the temple an edge of danger. It is *not* intended that they be used to kill the party off, and if play is going reasonably well, these monsters should not be encountered save as a minor problem that needs to be overcome before the PCs get to the Scroll Room (area 9).

Huge Tarantulas (5): AC 6; MV 18"; HD 2 + 2; hp 2d8; #AT 1; D 1-6 + paralysis poison; AL N; save vs. poison or be paralyzed for 2d6 turns. The sand pile does not affect their movement or combat, but the tunnel to their lair constricts them, giving them a penalty of -4 to hit while they are in it.

9. Scroll Room

The walls of this 20-foot-wide by 30-foot-long room are lined with racks of bone scroll cases. Like those elsewhere in this building, the floor is tilted toward the southwest, and the west end of the room has filled entirely with sand. On the floor in the east end lies a statue broken into many pieces, the carved table that obviously once supported the statue upended in the rubble.

The bone cases are empty. The broken statuary partly conceals a tablet that the statue once held. The upper and lower portions of the tablet have been smashed, but the central section is still readable, its message written in the ancient alphabet. This message is reproduced on page 39 as Inscription 7C; the incantation reads as follows:

... thus facing the great doors, and passing the right hand before them speak "Sakha al Jinni." Then approach the first and speak "Alhamduhla," so shall the way be open unto you. Speak then "Bismilla" and "Duban" and thee shall be within thy hand's reach of the greatest of all ...

10. Room of the Guardians

The walls of this 20-foot-wide hall and its ceiling fade into the darkness, made deeper by the black marble that has been used in its construction. Three pairs of huge statues stand sentry with their backs flush against the side walls, the first pair 15 feet from the doors. So tall are they that their heads are not visible in the darkness, and the staff each holds is as tall or taller. The room, like all the others encountered, slants toward the southwest.

Read the following description only if light is cast far enough into the room to illuminate the back wall and the ceiling.

The hall is 60 feet long, with a 60-foot ceiling. The statues are 50 feet tall, with staves that reach the ceiling. Against the back wall of the hall is what appears to be an altar of white marble. Centered on the white marble platform lies a huge black gem, its curved surface highly polished.

The white marble altar is the lead-lined box imprisoning the Efrete Pasha Khalitharius. The black gem is the Star of Aga-Pelar, one of the five Star Gems of Martek. Its function is to seal the lead box holding the efrete and to bind him within it. It will be needed by the party to locate and enter the Tomb of Martek.

Before the altar can be reached, three magical traps must be circumvented. The tablet in the Scroll Room (area 9) gives the magical incantations that will disarm the traps, but each has other ways that are effective.

The traps appear to be cloth curtains hanging between the staves of the statues. There is no way to get over or around the traps. In describing the appearance of the traps to the players, it is important that no clue to the actual functioning of the trap is given. Getting by these traps is the main play in this adventure area, and the players should be allowed to figure out the solutions themselves. Each trap has a description to be read as the PCs approach it.

As you approach within 10 feet of the first pair of statues, a thin veil of blue silk appears between them. As sheer as the finest mist, this veil appears to hang between the staves the statues bear.

This curtain is in fact a wall of absolute cold. It will freeze solid anything passing through it.

Should the PCs throw something through the curtain, it will pass through easily and then shatter with a musical tinkle as it hits the floor beyond, regardless of what was thrown through. Liquids will freeze into ice, soft solids will freeze hard and brittle, and hard solids will

become intensely brittle.

If any part of a PC touches the curtain or thrusts something through it, he/she will be seen to be covered with the blue veil, no matter how far from the hanging curtain he may be. The player should make a save vs. spells. If the roll is unsuccessful, the trap will have frozen the character instantly, turning him blue and frosty all over and giving 3d6 damage points. All the PC's implements are frozen to the character and cannot be removed. If the save is successful, the PC will take half damage and remain unfrozen.

Unless the damage kills a frozen PC, he/she is not dead and may be revived. There are several methods for doing this. The easiest would be to slowly thaw the PC; after a slow thaw, a successful system shock roll will allow the character to be revived. Another method would be to defrost the character magically by using a high-intensity fire spell such as *fireball* or *flame strike*. Such spells will not harm the frozen PC, but will instantly defrost him/her.

The curtain may be removed most easily by speaking the word "Alhamduhla" as mentioned on the tablet in the Scroll Room (area 9). It also may be removed by casting *dispel magic*; assume the spell is 10th-level magic when judging success. The least elegant way of circumventing the trap would be to do 50 points of magical fire damage against it, as with *fireball*, *flame strike*, *burning hands*, or *wall of fire*.

As soon as a PC passes between the first pair of statues, the second trap is activated, even if the first trap has not been bested. Read the description below.

A curtain of yellow satin appears between the second pair of statues. Hanging between the staves they bear, this curtain is translucent, but opaque enough to conceal all but the vague outlines of things beyond it. A sharp smell assails the nostrils.

This curtain serves to conduct intense electrical charges from the staff on the right to the one on the left. The sharp smell is that of ozone, which may be recognized by rangers, elves, dwarves, and magic users that know the spell *lightning bolt*.

If something solid is thrown through the curtain, it will be engulfed in a brilliant flash. Allow magical weapons or devices a saving throw, but all other items should be melted or burned. Describe only the effects, such as the intense sharp odor, the sound of splattering liquid, or the smell of burning leather. The lightning strike happens so suddenly that the PCs cannot tell whether it travels from right to left or vice versa.

Players contacting the curtain themselves or with something conductive (such as metal) will be seen to be engulfed in a brilliant flash that

will cause the hair on the other PCs to stand on end. Ask the player to make a saving throw vs. rods. If the save is unsuccessful, the PC will suffer 5d6 damage points. All iron/steel carried or worn will become magnetized unless it is magical; the magnetic effect should be judged to the PC's detriment if possible. Those making saving throws will take only half damage.

The curtain is removed most easily by saying the word "Bismilla" found on the tablet in the Scroll Room (area 9). *Dispel Magic* cast against 10th-level magic will also work, if successful. The least elegant method would be to suffer the effects of the lightning until a total of 200 damage points have been inflicted. A very elegant solution would be to short-circuit the two staves by laying metal between them; when the circuit is complete, the two statues will blow apart, removing the curtain permanently.

As soon as a PC passes between the second pair of statues, even if the first two traps have not been disarmed, read this description.

A shimmering curtain of flame-orange velvet appears between the third pair of statues. Appearing to drape in folds from something suspended between the staves the statues bear, the velvet reflects golden yellow and deep red in the highlights and shadows. Nothing can be seen beyond the curtain.

This curtain is a wall of flame. If the PCs throw anything at the curtain, a sheet of fire will be seen to descend from the top of the curtain, instantly engulfing the object. Anything made of flammable material will be consumed in the flames. Iron will be heated red-hot, and lead, gold, silver, or copper will be melted. Describe the effects that the PCs would notice, such as the smell of burning leather.

If a PC touches or thrusts something through the drapery, they will be seen to be engulfed in a flow of flame that descends the curtain. Ask the player to make a saving throw vs. breath weapons. An unsuccessful save will give the PC 5d10 damage points, which a successful save will cut in half.

This final curtain may be removed most easily by saying the word "Duban" found on the tablet in the Scroll Room (area 9). Again, a successful *Dispel Magic* cast against 10th-level magic will also work. The curtain will be dispelled when it has inflicted 500 damage points to the PCs. Additionally, 50 damage points from spells that create intense cold, such as *cone of cold* or *wall of ice*, will destroy the field as well.

As soon as a PC is able to see the end of the hall at close range, read this description.

The white marble of the altar against the rear wall begins to pulse as though with an inner light. The only thing on the altar top is a fist-sized polished stone of midnight black, with a brilliant white star dividing it into six wedges. Now, it can be seen that the pulsing light covering the white marble emanates from within the stone's star. As though in time with a beating heart, the light of the star brightens, flows out through the gem, and washes the marble in its brilliance. So deep is the black of the stone itself that it appears to be without depth.

The stone, the black star sapphire called the Star of Aga-Pelar, will radiate intense magic, so much that any magical detection spell will seem to be directed to the stone itself. Close inspection will reveal that it does not lie atop the altar, but instead is set into the white marble surface.

It cannot be removed easily, but any determined force eventually will free the gem. When this occurs, read the following.

The stone comes free all of a sudden. The pulsating light seems to flow back into the midnight black of the stone, leaving only the star as a glimpse of its former presence. A tiny bit of dull grey metal clings to the base of the gemstone, and a faint wisp of incense wafts from the stone's setting. As from afar, a guttural chuckle flows forth, gaining in power and volume until, like a wave cresting against a breakwater, it crashes through the hall. The laughter's crest passed, only the echoes remain.

This should give the players a clue that they have released the efreet; this is exactly as Martek prophesied. No contact with the efreet is intended, though resourceful players might attempt magical interference with the wisp of smoke that is Khalitharius in *gaseous form*. Should this occur, be creative in the ensuing confrontation; Khalitharius is not intended to seriously harm the party.

Kalitharius, Efreet Pasha, Vizier to the Fire Sultan: AC 3; MV 24"/24"; HD 12; hp 101; #AT 2; D 2-20/2-20; AL N, with LE tendencies.

The Pasha can perform the following as a 15th-level magic user, at will: *fireball*, *flame strike*, *detect magic*, *enlarge*, *invisible*, *assume gaseous form*, *wall of fire*, *polymorph self*. He can create illusions with both visible and aural effects, and fulfill another's *wish*, although loath to do so. If he appears, his form will fill the room to its full height, the very stone quaking under his arrival. Being of a snobbish royalty, he will not at all disposed to treat the party kindly, though they will escape his full wrath as they did release him. He is in a hurry to get out of this place where he has been kept for over 1,000 years and wants to see the world above. He is not bound to perform a service for the players characters. He will laugh at them and, after informing them of his plans to lay waste to all civilization, will rush out through the temple doors. He will not fight the characters unless attacked.

7A Կ՛ լճՄ իշ Եղևճիւմս ք լսօ Կրօօս
 ԻԿ Խօփս Գի՛ ԻԿ ԶԵ՛՛՛ ԿԻ՛՛ ԻԿ ԿԻ՛՛՛՛՛՛՛
 Կ Ե՛՛՛ Ե՛՛՛՛՛՛՛ ք Ի՛՛՛ ԶԵ՛՛՛ Ե՛՛՛՛՛՛՛ ԿԻ՛՛՛
 ԽԿ ք լճ՛ Կ ճ Ե՛՛՛՛՛ ԻԿ ԿԻ՛՛՛
 ԽԿԻ՛՛ Գի՛ ԽԵ՛՛ ԽԿԵ՛՛՛ ք

7B ԵԿ լճ՛ Ե՛՛՛՛՛՛՛ ԻԿ ԻԿ՛՛՛՛՛՛՛ ԽԿ ք Ի՛՛
 իշ ԻԿ Ի՛՛՛՛՛՛՛ ԻԿ՛՛՛՛՛՛՛ Ե՛՛ Ե՛՛՛՛՛ ք

7C Ի՛՛՛ Ի՛՛՛՛՛՛՛ ԻԿ ԶԵ՛՛՛ Ե՛՛՛՛՛՛՛ Ե՛՛՛՛՛՛՛ ԻԿ
 ԿԻ՛՛ Ի՛՛՛՛՛՛՛ Ե՛՛՛՛՛՛՛՛ ԻԿ ԶԵ՛՛՛ ք Ի՛՛՛՛՛՛՛՛՛ ք
 ԻԿ Ի՛՛՛՛՛՛՛՛ ԻԿ ԶԵ՛՛՛՛՛՛՛՛՛ Ե՛՛՛՛՛՛՛՛՛ ք
 ԶԵ՛՛՛՛՛՛՛՛ ԻԿ ԽԵ՛՛՛ Ե՛՛՛՛՛՛՛՛՛ Ե՛՛՛՛՛՛՛՛՛ ք
 ք Ե՛՛՛՛՛՛՛՛՛ ք Ե՛՛՛՛՛՛՛՛՛ ք Ե՛՛՛՛՛՛՛՛՛ ք
 ԽԻ՛՛՛՛՛՛՛՛ Ի՛՛ Ի՛՛՛՛՛՛՛՛՛՛ ԽԵ՛՛՛՛ ԻԿ ԶԵ՛՛՛՛՛՛՛՛ ք Գի՛ Գի՛

Chapter 8: Pyramid of Amun-Re

The pyramid has five main playing areas: The Plundered Tomb, Kordan's Master Maze, The Halls of the Upper Priesthood, The Gauntlet, and The Tomb. Each of these has its own problems to solve, tricks and traps to defeat, and so on.

Background

The Pyramid and The Temple

The tombs of the pharaohs were not just burial grounds. They were complex religious places that were used to change the dead pharaohs into gods. Temples such as this one were used in the sacred processes that readied the pharaohs for their trips to heaven and the next world.

The Plundered Tomb

All of the rooms in this area were prepared to fool potential robbers. The secret doors were purposely made to be easy to discover, and the rubble was placed there before Amun-Re was even laid to rest. The purpose was to lure grave-robbers into thinking that they were not the first to arrive and were thus too late to remove the treasure.

Kordan's Master Maze

This is the maze level of Amun-Re's tomb. It has impressive magical spells that confuse direction and distance in certain areas.

Halls of the Upper Priesthood

This level was to be the final residence of Amun-Re's Higher Priests. These priests were to be sealed into the pyramid after bringing Amun-Re to his final resting place. The priests would then live out the remainder of their lives in these halls.

Star of Mo-Pelar

This is a large, rounded opal, 5 inches in diameter. It has the powers of a *Gem of True Seeing*. It is necessary to further play in this adventure, as without it is required to resurrect Martek. Given by Martek to the Pharaohs of Bakar, Amun-Re locked it up here upon his death.

Expected Play

The Pyramid

The entire pyramid radiates magic. *Teleport* spells going into or out of the pyramid will not work unless the characters that are teleporting have the Star of Mo-Pelar with them. *Teleport* spells will work normally within the pyramid. There is a player map of the pyramid exterior on the colored map sheet.

Because the waterways in the the pyramid form the quickest way to the Tomb of Amun-Re, and because the levels are interconnected at several places, a special view of the arrangement of the levels is included in the text. Before playing this adventure area, make sure you

understand how the water flows, from the West Water Storage Vault up to the Tomb Level and back down.

Kordan's Master Maze

There are two ways to enter this level from the Plundered Tomb Level. The first is via the offering basin teleport in the East Offering Temple (Plundered Tomb area 4). This will leave the PCs disoriented, standing in the Welcome Room (area 1), as discussed below. The second is by climbing up the sluiceway down which the Waters of Athis flow into the East Water Storage Silo (Plundered Tomb area 6). They will be in the Well of Questions (area 28), where orientation should not be a problem until the Maze is entered.

A clear understanding of the function of the maze will be necessary to run this section of the adventure. Take time to study the details of area 2. While in the maze, players will not know which way is north, south, east or west. Give all directional descriptions as: "left," "right," "straight ahead," or "behind." For example, a description of a typical maze might be: "You enter the end of a 10-foot wide by 30-foot long corridor with arched exits in the center of the left and right walls." Not knowing the compass directions, the players will also have to give their directions in terms of "left" and "right."

Pyramid Temple Encounter Areas

For play in the Pyramid Temple, refer to Map 8-1 in the *Map Booklet* and the appropriate inscriptions on the reverse of the DM's map.

Temple Random Encounters

Check for random encounters once every three turns. A roll of 1 or 2 on 1d6 indicates that an encounter takes place. If an encounter is indicated, roll 1d6 and use the corresponding encounter number from the following table.

Temple Random Encounter Table

- 1-3. 2d6 Dervishes: AC 6; MV 12"; F 4; #AT 1; D 1d8 + 2; AL LN. These dervishes will be drunk 25% of the time.
4. 1d8 Bandits: AC 7; MV 12"; F 1; #AT 1; D 1d6; AL NE. They seek the way into the tomb.
5. 3 Dwarves: AC 4; MV 6"; F 4; #AT 1; D 1d8; AL LN. They are looking for their comrades, who are already in the Plundered Tomb Level.
6. 35 Giant Rats: AC 7; MV 12"; HD 1; #AT 1; D 1-3 + Disease; AL N.

1. Exterior of Pyramid and Temple

The pyramid is about 750 feet square at the base, rising to a height of at least 700 feet. The highly polished rock that forms its exterior is untouched by desert sands, in contrast to the rock of the 20-foot-high wall that surrounds it.

The pyramid sides face the compass points. The only break in the guarding wall is the temple to the south. Entrance is obviously via a platform that opens in the south face, 50 feet above the ground. Stairs climb the pyramid's south face from a walkway connecting the rear of the temple and the pyramid.

Like the stone of the surrounding wall, the stone of the temple is worn by time, though still solid and sturdy. There are no windows in the temple wall, and only one entrance, gained via two staircases flank a circular basin, climbing 30 feet to the temple porch. The temple's roof is capped by one large and two small domes.

A broken lime-cement basin, 100 feet in diameter, with no apparent openings in the bottom lies within the embrace of the stairs to the temple entryway. The basin obviously once contained water, which emptied into a deep channel in the desert ground. This channel leads away from the temple south, passing the building ruins there before turning east and then north, out into the great desert.

The basin is the Fountain of Athis. After the construction of the pyramid, irrigation water for the entire valley sprang from this source. It was originally filled by a permanent *teleport* spell that moved an incredible volume of water from the pyramid to this spot. The spell was stopped by Amun-Re's curse.

The water still flows inside the pyramid, and the *teleport* spell will begin to function again when the curse is broken. This will cause the basin to fill, overflow, and send the life-giving water out into the desert once more, finding and filling its original channel. Enough water is present to cause the entire area to become fertile again, though this will take some years.

2. Temple Entryway

The stairs leading to the temple's porch are of stone, pocked and pitted by the desert sands. Wide banisters of stone flank the steps, their graceful arcs leading to a semi-circular protrusion from the porch. Six pillars hold up the porch roof. Two arched doors of bronze stand closed in the temple wall, guarded by two humans.

Two dervishes guard the huge bronze doors. They will verbally challenge anyone approaching the top of the stairs, walking forward until they bar entrance to the porch itself. They will attack if the PCs do not give a response that indicates their reverence for this place, such as "We come to worship at this temple." The dervishes are fanatical, and will fight to the death.

Dervish guards: AC 6; MV 12"; F 5; hp 35,25; #AT 1; D 1d8+2; AL LN.

3. Corridor of the Supplicant

A 10-foot-wide corridor extends from the outer doors 20 feet to a second set of double doors.

4. High Altar of Amun-Re

This 30-foot wide by 40-foot long room is lit by torches attached to the walls. The torches cast flickering light on the very decorative wall carvings and the high, domed ceiling. A human figure, dressed in vaguely priestly garb, stands at an altar in front of a huge statue, where he is reading from a large white book with gleaming metal fittings. Five other humans, dressed like the two guards on the temple porch, stand around him, casually studying the wall carvings.

Before the PCs can deal with the room itself or any of its contents, they must deal with the room's occupants. The humans are all dervishes, lead by their holy man, the Iaseda. They are attempting, with little success, to find some clue to the whereabouts of a dervish band and his group that entered the pyramid a week ago and did not return. The Iaseda is having little luck with the book, as the written form is strange to him. His reactions are typically dervish (see Chapter 2: Background and Storyline). Under no circumstances will he knowingly release the book from his hands.

Holy Iaseda: AC 4; MV 12"; C 5; hp 28; #AT 1; D 1d4+1; AL LN. He carries a horse-man's flail, and can use these spells: *command*, *cure light wounds*, *sanctuary*, *know alignment*, *snake charm*, *spiritual hammer*, *cause blindness*.

5 Dervishes: AC 6; MV 12"; F 4; hp 23,22,23,17,30; #AT 1; D 1d8+2; AL LN.

When the PCs have a chance to inspect the room, read them this description.

In addition to the double doors in the south end, the room has doorways in the north end of the side walls. The statue is of a pharaoh; it is cut from stone different than that

of the surrounding walls or altar. Several of the wall panels are inscribed with writings carved in the ancient alphabet. Writings appear on the outside of the white book, probably the title; they, too, are written in an ancient alphabet.

The statue actually is a secret door; it swings outward into the space between the wall and the altar. Behind it is an area 10 feet wide and 20 feet deep with an arched ceiling 10 feet tall. This is the receiving end of a one-way teleportation device designed for the king's transfer of spirit into the stone. Though the area radiates magic because of the teleportation device, entering it has no effect.

Inspecting the wall carvings will show that a rune is often repeated in the carvings. This inscription is reproduced as Inscription 8A on the reverse of the DM's fold-up map; it is translated as:

Though his spirit lies far from us in heaven westward, into this likeness does his spirit come that he may commune with men.

The book is the Tome of Amun-Re. Its title, on the exterior, and its contents are written in the ancient alphabet of the area. The title is reproduced as Inscription 8B on the reverse of the

DM's fold-up map. The contents are translated on page 42; this book is not reproduced in the ancient alphabet.

5. Holy Circle of Osiris

This circular room is 40 feet in diameter. In the center of the room's west side stands a large, white marble altar. Behind the altar, a large statue of a man carved from greenish stone stares down with eyes that appear to have jewelled pupils.

Depending on how the room is entered, describe either the corridor to the north, with a door on the west wall, or the stairway up to the east, with a door at the top.

The statue is of Osiris. The pupils are small star rubies, each worth 1550 gp. It is fairly simple matter to cut the gemstones out of the sockets, but the dervish consider such an act sacrilege to this holy place. Any dervish witnessing such an act will mark the characters removing the gems for "Bloodquest" (see Chapter 2: Background and Storyline). Even if no dervish is present when the gemstones are removed, there is a 15% cumulative chance per turn that a wandering dervish will notice their absence... and the dervishes are excellent trackers.

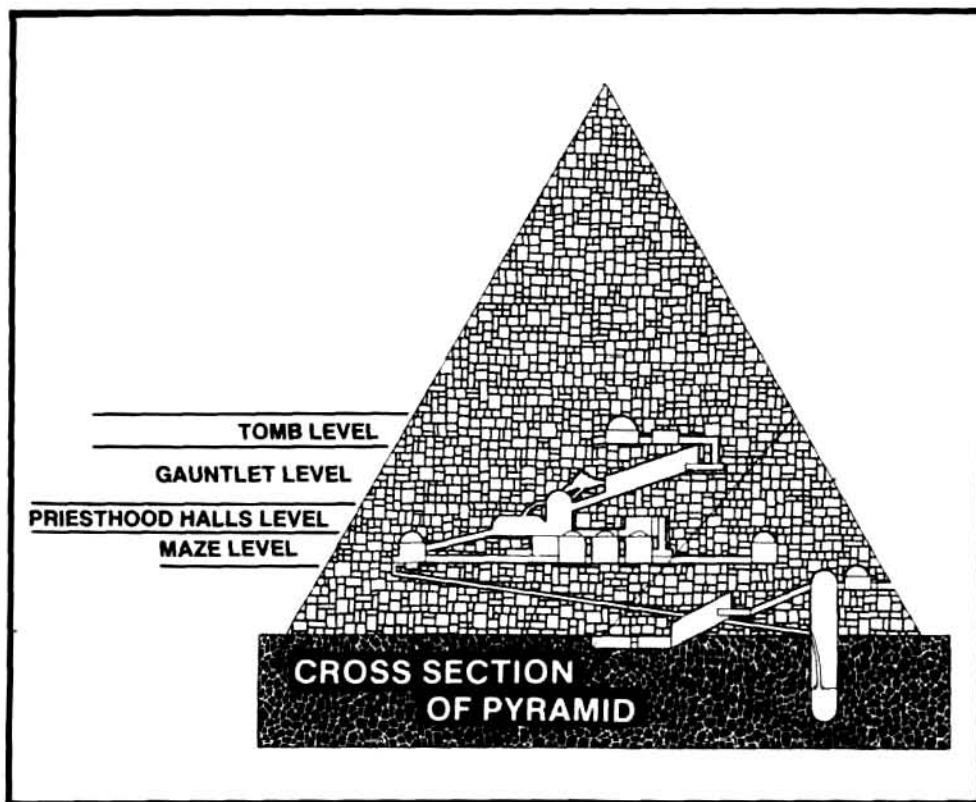

Book Of Amun-Re

Verse 1

I, Amun-Re, do set forth a record of myself and of my dealings with this world. The years fold back in my mind. There were green and fertile fields in my youth. Throughout the land flowers grew in abundance in the thick and lush forests, filling the air with pure fragrance and well-being. Traders in their sandships would travel a year or more to come to our oasis on the borderlands and bid a high price for our sweet perfumes. Fruits and sweet meats came from our fields, while within the city of Terbakar, the mills turned out a secretly woven cloth, fine enough for kings and queens.

Verse 2

The River of Athis was the mother of our land, giving life itself with its waters. Springing forth from the courtyard of the Old Palace, Athis blossomed all that she touched, even in the harsh Borderland, and gave strength and health to her children. My father would sit with me beside the spring and tell me the stories of her wonderful power and her blessings to the land: the very gift of Isis. There, by the raging torrents of Athis, I grow strong in the love of my father, as we played and learned of life and its living.

Verse 3

But not by him alone was I instructed. Daily was I taught by the priest and wisemen of my country about the order of kings and the heavens. I learned of the passing of the kings and how they, after death, journey to Heaven Westward, making the long passage in their burial ships, sailing across the River of Death until they reach the farthest shore. There, they are admitted to their separate estates by Osiris, God of Death, according to the riches they have brought with them. I also learned of wicked men whose minds had darkened and forgotten the old ways, who plundered the Old One's tombs and took their riches, thus robbing them of their place in Heaven Westward. As a boy, I would often cry in the night at such thoughts and fear of judgment of Osiris lodged in my heart.

Verse 4

My father had built the tomb for himself to guard against just such wickedness. Yet, only a few years after my father's death, there were whisperings that even his great burial place had been desecrated. I was tortured by thoughts of his spirit wandering forever, alone. Cloaked in the darkness of deepest night, I went to my father's tomb. No priest followed me to witness my trespass upon the world of the dead. I carefully slipped past the traps that barred the way when, suddenly, I came upon his sarcophagus.

Verse 5

I gazed through watery eyes at the broken clay pots that had contained the gold. The once jewel-encrusted hull of my father's ship was barren and scarred with gouges. I knew with certainty that he could not have approached the great Osiris in that mockery of a boat, without so much as a humble clay token.

Verse 6

In weakness and horror, I fell upon my father's sarcophagus and stared at the scared wooden image of my father's face. It had once been covered with the purest of gold leaf. His golden Staff of Ruling was nowhere to be found. I lay myself upon the scarred surface to hide its imperfections, weeping great tears of fury. My torch went out as, too, did the light within my soul. I emerged from the tomb as the sun arose. Clutching my own staff, I swore by all the gods that I would not be cheated of my place in Heaven Westward.

Tale of the Years

Verse 1

But it was said throughout the land that from that time forth, those who entered the tomb either came forth saying that its riches were already plundered or else they never returned at all.

Verse 2

The fact that no treasure has ever been brought out from the tomb is emphasized by the fact that the curse is still in effect.

Verse 3

Munafik, the Chief High Priest of Amun-Re, was also something of a sage, a lover of book-lore and of learning.

Verse 4

It was said later that Munafik may have had a hand in the curse, for of all the books he read, many were of the black arts, and the prophets that passed this way avoided him as a beggar would a good bath.

Verse 5

Though there had been much bad talk about Amun-Re, it was generally known by the people and priests alike that he was the greatest of the gods in Heaven Westward, for he alone manifested his power in his own temple.

Verse 6

Sacrifices of food and gold were brought daily to lay on the altars before the statues in the small worship temples left and right from the stair entrance to the tomb.

Verse 7

It is our priesthood rite that whatsoever Osiris accepts he will take from the altar and that which he wishes the priests to have, he leave on the altar. This profited the priests greatly, except that all offerings left in the East Temple would disappear and never be found again.

Verse 8

Several priests, upset to see their assets disappearing, searched the room carefully, and they, too, disappeared. The temple became a most halloed spot, so that all who wished to give offering came to that temple only. The priesthood then became unprofitable and our doctrine had to be changed—tourism turned the trick.

Verse 9

Offerings were often made, for a passage was always provided between the tomb of the king and his likeness, whereby his spirit might pass into his ordained statue and live within the stone we worship here. Such a passage was always provided for the kings that they might live among us once more.

Verse 10

The phrases of our priesthood are always to be said in their order. I once tried to say the prayer: "Cleanse our feet and live in our land once again," but got the order confused and, so, cried out, "Cleanse our land and live in our feet once again." It rained for three weeks during which time the priest could do nothing but dance the wala-tamba night and day.

6. Worship Room

The room, 20 feet wide by 40 feet long, has been neglected for years. It gives off a slight herbal smell and appears empty.

7. Priests' Quarters

This unlit corridor runs north and south. The end of the corridor is lost in darkness. There are 10-foot square cells opening off to either side.

The corridor is 60 feet long altogether. Depending on how this room is entered, describe the darkened corridor to the north, with the door at the end, or the darkened corridor to the south, with a set of stairs running up on the west.

In each of the 10 cells, there is a bunk of hard wood and a woolen blanket. A total of 27 Dervishes are resting in the cells, unseen as the PCs enter the room. There is a base 70% chance that the NPCs in each cell are asleep; modify this for the actual circumstances if the party does not take pains to be silent. If no attempt at silence is made, the dervishes who are awake will listen to the conversation, reacting appropriately to any talk of desecration or plunder. If silence is attempted, roll for surprise as the party approaches each cell.

Dervishes: AC 6; MV 12"; F 4; hp see below; #AT 1; D 1d8 + 2; AL LN. Each dervish carries 4d10 cp. The number of dervishes in each cell and their hit points are as follows:

Cell	Number	
a	4	2,7,1,2
b	7	1,2,10,2,2,2,9
c	2	1,10
d	3	5,4,5
e	None	
f	5	3,1,9,8,2
g	None	
h	4	2,10,10,2
i	2	2,5
j	None	

8. High Priest's Temple

You enter a small temple 30 feet across east to west and 20 feet deep north to south. There is a door in the center of the south wall and another at the east end of the north wall. Within this dark and smoky room, a dull red glow is visible from a pile of burning incense in the center of the room. Against the west wall stands a statue of a pharaoh, his hands forming an altar platform 5 feet above the floor. Prostrate on the ground in front of the statue is a human.

Assistant Holy Iasada: AC 3; MV 12"; C 5; hp 21; #AT 1; D 1d8; AL LN. He wears +2 chainmail, which will fit perfectly anyone who wears it. He can use these spells: *bless*, *detect evil*, *cause fear*, *know alignment*, *spiritual hammer*, *silence*, *bestow curse*.

9. Exit of the Kings

The north side of this room is 30 feet across, and the room is 20 feet deep to the south. To the east and west, at the northern end of the side walls, stairs lead up to corridors. Light falls through an open archway in the center of the north wall.

Plundered Tomb Level Random Encounters

Check for random encounters once every three turns. A roll of 1 on 1d6 indicates that an encounter takes place. If an encounter is indicated, roll 1d6 and use the corresponding encounter number from the following table.

Plundered Tomb Random Encounter Table

- 1-3. 2d4 Dervishes: AC 6; MV 12"; F 4; #AT 1; D 1d8 + 2; AL LN.
4. 2d4 Bandits: AC 7; MV 12"; F 1; #AT 1; D 1d6; AL NE. These gentlemen are bent on plunder.
5. 1d6 Dwarves: AC 4; MV 6"; F 4; #AT 1; D



The northern archway opens onto the courtyard between the tomb and its surrounding wall. A well-worn path, raised 15 to 20 feet above the courtyard, leads straight from this doorway across the intervening 50 feet to the base of the pyramid. Here, a stairway leads to an opening 50 feet up the south face of the pyramid.

Plundered Tomb Level Encounter Areas

For play in the Plundered Tomb Level, refer to Map 8-2 in the *Map Booklet* and the appropriate inscriptions on the reverse of the DM's fold-up map.

1d8; AL LN. So are these guys.

6. 4d10 Giant Rats: AC 7; MV 12"; HD 1; #AT 1; D 1-3 + Disease; AL N. Very hungry, these fellows.

1. Tomb Entrance

The stairs climb from the walkway that leads from the rear of the temple to the pyramid's south face. They are as highly polished as the pyramid walls, reflecting the light from a mirror-smooth finish untouched by the ravages of desert sandstorms. The stairs rise a total of 50 feet above the courtyard.

At the top of the stairs is the platform obviously giving access into the pyramid. The platform is 50 feet across at the front, narrowing to 30 feet at the back wall. Animals have been intricately carved on the stone walls flanking the arched opening into the pyramid.

In the shadows at the rear of the platform, two figures stand on either side of the arched opening.

In order to get through the entrance, the PCs will have to deal with the dervish guards, Atfez and Pachi, who will react as typical dervishes. The carvings are only decorative.

2 Dervish Guards: AC 6; MV 12"; F 3; hp 16, 18; #AT 1; D 1d8+2; AL LN. Atfez holds 22 cp, and Pachi has 10 sp and "a pretty stone" he found (a gem worth 100 gp).

2. Main Worship Hall

This is a vast room of cool darkness with a flat ceiling 20 feet high. Support pillars, four on each side, stand 10 feet from the east and west walls. Both the walls and the pillars are of intricate design. Just inside the entrance, at the south end of the side walls, 4-foot-wide corridors lead to the east and to the west.

When the PCs have advanced far enough into the room to see it all, read the following description.

The room is roughly 50 feet square. There is a 20-foot-tall statue of a pharaoh in the center of the north wall. The statue is carved from a different stone than the rest of the walls.

The statue is a secret door leading to the Worship Room (area 8). It swings out toward the right.

3. West Offering Temple

The corridor opens onto a 30-foot-square room with 20-foot walls rising to a domed ceiling. In the center of the north wall stands a statue of the pharaoh you have come to believe is Amun-Re; it is formed of a different stone from the room's walls. The walls are covered with inscriptions in an ancient alphabet.

The statue is a secret door that pulls open to the right. It reveals a 10-foot-wide corridor running 20 feet to the north and intersecting the east/west corridor between the West Water Storage Vault (area 5) and the Worship Room

(area 8).

The inscriptions are reproduced as Inscriptions 8C-8H on the reverse of the DM's fold-up map; they are translated as follows:

8C: It was said throughout the land that from that time forth, those who entered the tomb either came forth saying that its riches were already plundered or else they never returned at all.

8D: That day did the river dry and the rains disappear. The arid sun burned into the land, and everything withered from its gaze.

8E: The people, too, dried up and blew away like the grass that withered beneath their feet.

8F: All now that remains is I, who tend this temple, in the hopes that some soul might turn that terrible wrath of Amun-Re. I also sell trinkets to the tradesmen who come, although lately sales have been low.

8G: The building of the pyramid was a colossal feat, especially in the bad years. The gold piece had been lowered in value so many times that the people began to wonder if there was any future in the gold piece at all.

8H: The trade business died away after the first four years. Now, here I am, holding twelve cases of pyramid statues. Oh, for the days when a priest could earn an honest gold piece.

4. East Offering Temple

The corridor opens onto a room filled with prostrate robed figures, bowing in worship toward a statue in the center of the north wall. They are chanting in unison, the sound a mere murmur. The 30-foot-square room has 20-foot walls capped by a domed ceiling. Torches attached to the walls brightly illuminate the five inscriptions on the walls.

The statue is of a pharaoh you have come to believe is Amun-Re. With arms outstretched, it holds an altar bowl of blazing fire near his chest 15 feet above the floor. A stone staircase leads up to the bowl.

One of the figures, clad in what might be clerical garb, throws an offering into the bowl. The flames leap 10 feet, nearly to the dome above, obscuring the face of the statue. They die back of an instant, and the low chant is at once resumed.

The bowing figures are dervish worshippers, who must be dealt with anything else in the

room may be. The worship is being led by the Assistant Holy Iaseda. If the NPCs react favorably to the party, they might tell them that they are here offering alms to this deity for the return of their great leader and his men, who disappeared here 10 days ago. They know that their great leader entered this room after having read something in a white book that indicated this was the correct entrance to the rest of the tomb. They believe that the offerings they make, because they vanish from the bowl, have been accepted by the gods.

Assistant Holy Iaseda: AC 4; MV 12"; C 5; hp 19; #AT 1; D 1d8; AL LN. The Iaseda can use these spells: *protection from evil*, *purify food and drink*, *sanctuary*, *chant*, *hold person*, *silence 15-foot radius*, *dispel magic*.

11 Dervishes: AC 6; MV 12"; F 3; hp 16,5,10,11,15,5,7,4,8,14,3; #AT 1; D 1d8+2; AL LN.

The inscriptions, which are written in the ancient alphabet of this land, are reproduced as Inscriptions 8I-8M on the reverse of the DM's fold-up map. They translate as follows:

8I: Though there had been much bad talk about Amun-Re, it was generally recognized by the people and priests alike that he was the greatest of the gods in heaven westward, for he alone manifested his power in his own temple.

8J: Sacrifices of food and gold were brought daily to lay on the altar before the statues in the small worship temples left and right from the stair entrance to the tomb.

8K: It is our priesthood rite that whatsoever Osiris accepts he will take from the altar and that which he wishes the priests to have, he leaves on the altar. This profitted the priests greatly, except that all offerings left in the east temple would disappear and never be found again.

8L: Several priests, upset to see their assets disappearing, searched the east temple, and they, too, disappeared. The temple became a most hallowed spot, so that all who wished to give offerings came to that temple only. The priesthood then became unprofitable and our doctrine had to be changed. Trade turned to trick.

8M: Offerings were often made, for a passage was always provided between the tomb of the King and his likeness,



whereby his spirit might pass into his ordained statue and live within the stone we worship here. Such a passage was always provided for the Kings that they may live among us once more.

The flames in the offering bowl burn with neither smoke nor heat, nor is there any apparent fuel source. Anything that is placed in the bowl vanishes in a spectacular upsurge of flame, as the PCs can see when the Assistant Holy laseda places a cloth-wrapped package in the bowl.

The bowl is a rather spectacular teleportation device to the Welcome Room (area 1) in Kordan's Master Maze. If a PC enters the bowl entirely, do not describe for *him* anything. Instead, describe for the remaining players what has happened by reading the following boxed text. Because the teleportation device will split the party, it is advisable not to let anyone know the fate of the vanished party member.

As soon as (name the PC here) is completely inside the offering bowl, the flames surge up, blocking his (her) from sight. When the flames die down immediately thereafter, the bowl is empty save for the flames. (Name the PC here) has vanished.

After concluding play in this room with the rest of the party, take any party members who were teleported aside and read for them the

descriptions of the experience and their present location in the Welcome Room (area 1) of Kordan's Master Maze. The flames have done them no damage. Continue with a split party as long as necessary.

5. West Water Storage Vault

The 10-foot wide arched corridor opens into a vertical circular shaft 30 feet in diameter. The shaft has wet, slime-covered walls dropping into darkness below and rising 30 feet to a domed ceiling above. The air here is very humid.

The shaft drops down 120 feet to murky water 30 feet deep. The waters of Athis (see area 6) fill the bottom of this shaft.

There is an underground connection between this area and the East Water Storage Silo (area 6). This tunnel is 15 feet in diameter and connects 10 feet from the bottom of the vault. There is a slow current through this tunnel in this direction from the connecting silo.

The water in the vault and the connecting tunnel is the Waters of Athis, which have healing properties within the tomb. Once per 24 hours, a person drinking the water while inside the pyramid will gain back 1d10 damage points. The pyramid concentrates cosmic energy to give the water its healing powers; the water will not have any healing powers outside of the pyramid.

It is from the bottom of this vault that the water was teleported out to the now-dry Fountain of Athis, which stands just before the temple. The water used to be created magically on the Halls of the Upper Priesthood level. When Amun-Re's curse took effect, the water stopped being created. Now, it is teleported from this place to The Pharaoh's True Way (Tomb Level area 1), where it begins its rapid downward journey once again. When the curse is broken, the waters will flow freely once again.

Should a PC happen onto the area wherein the water is teleported away continuously, he, too will be teleported. It is likely that this will split the party. Continue play in the vault, making no mention of the fate of the PC, who will not reappear.

Unless the party follows, run the PC separately, describing in *very* general terms the following tumultuous journey. The PC will be teleported to the top of the water Pillar of Athis (Gauntlet Level area 4). As the water plunges downward, he will fall with it, taking 1d6 damage points immediately. He will be carried through a duct and spilled out into the rapids of The Grand Hall of the Pharaohs (Gauntlet Level area 3); this passage, until he enters a duct at the rapids' foot, will give another 1d6 damage points. Eventually, he will be spewed out from the lion's mouth in the Dome of Flight (Priesthood Halls Level area 5). He will take an additional 1d6 damage points from the 30-foot fall to the pool below, from which adventuring may begin again. Should the PC die in the process, his body can eventually be found floating in this same pool.

6. East Water Storage Silo

The 10-foot-wide corridor opens onto a vertical shaft 30 feet in diameter. The wet and slimy walls drop down into darkness and rise 30 feet to the top of a domed ceiling. The air is very humid here, and the thunderous sound of cascading water fills the chamber.

The shaft drops 120 feet into turbulent and foaming white water 30 feet deep. Fifty feet below the arched entrance, water gushes from a 10-foot-diameter opening in the north wall, falling to the water below. This Sluiceway (area 7) leads up to Kordan's Master Maze. There is an underground tunnel connecting this silo with the West Water Storage Vault (area 5); this tunnel is 15 feet in diameter and enters 10 feet above the floor of the silo. The water here is Water of Athis (see area 5).

PYRAMID OVERVIEW

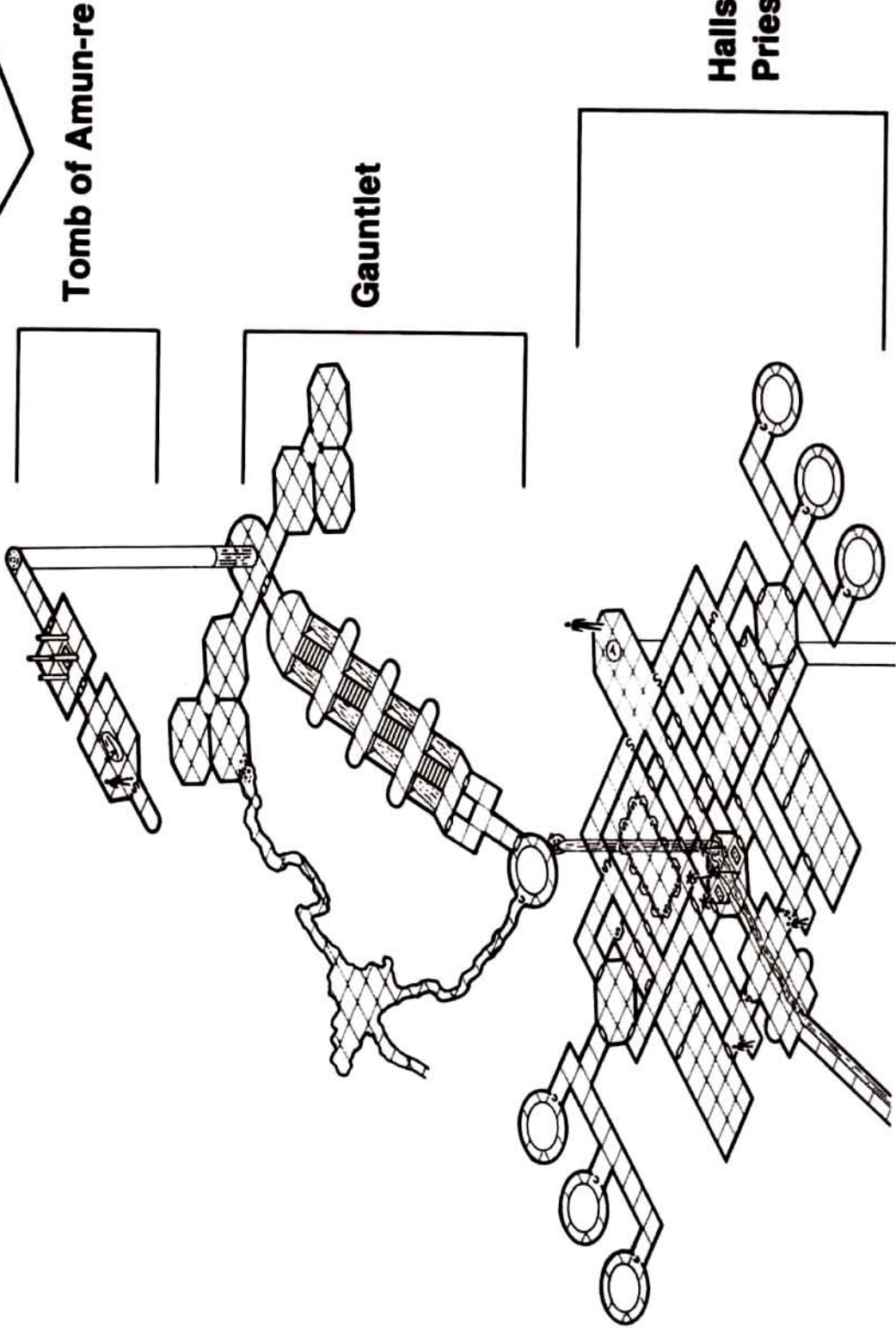
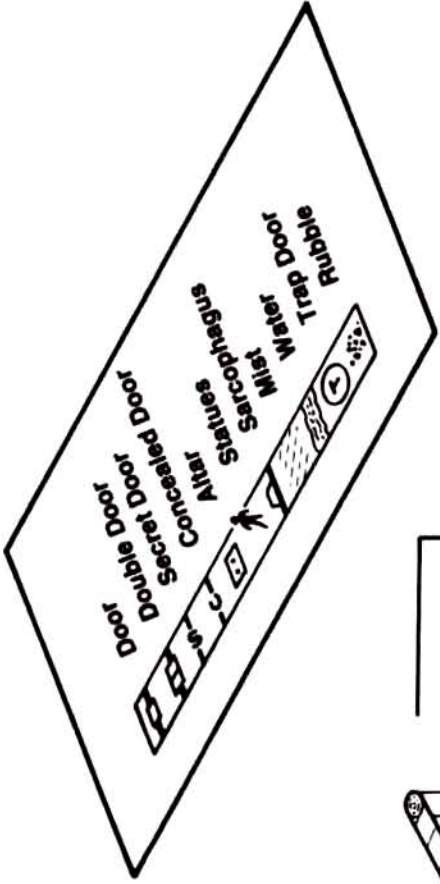

**Kordan's Master
Maze**

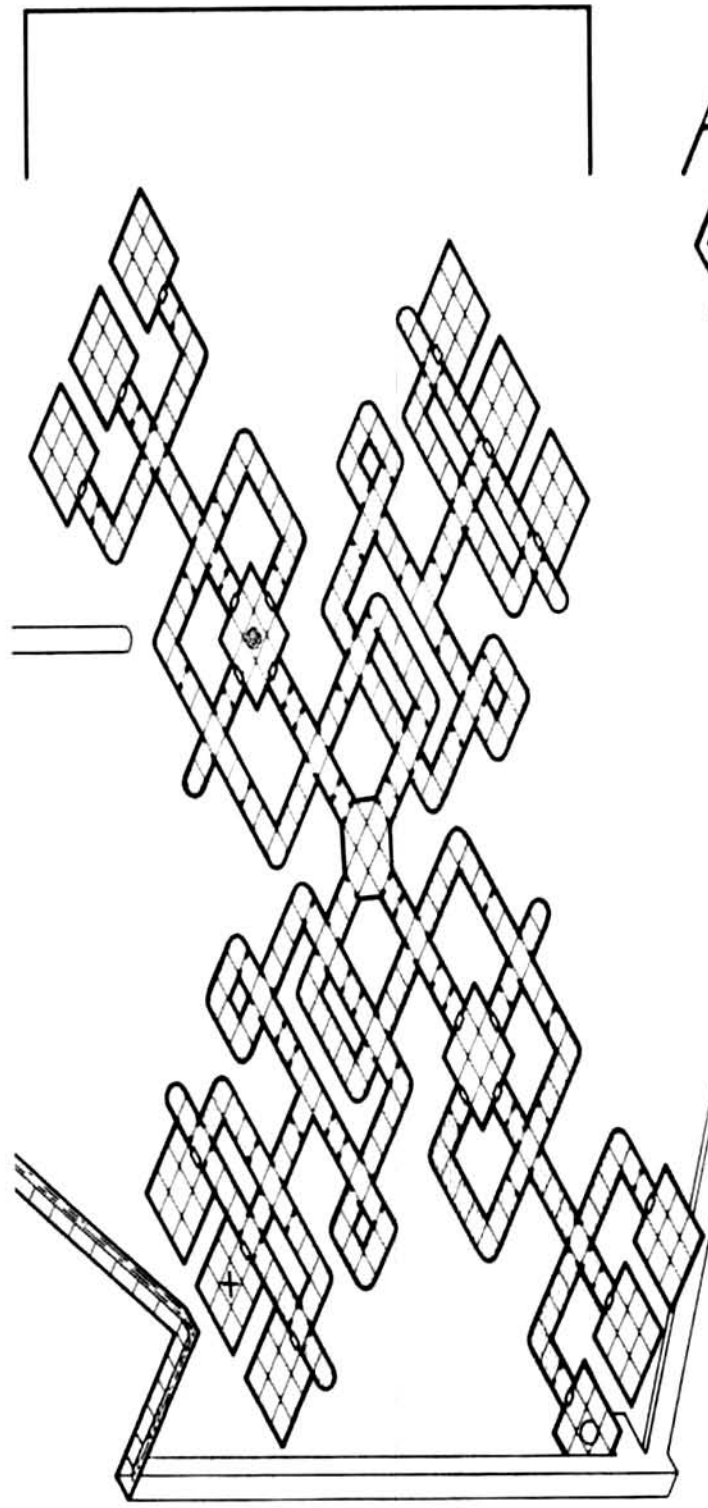

**Plundered
Tomb**

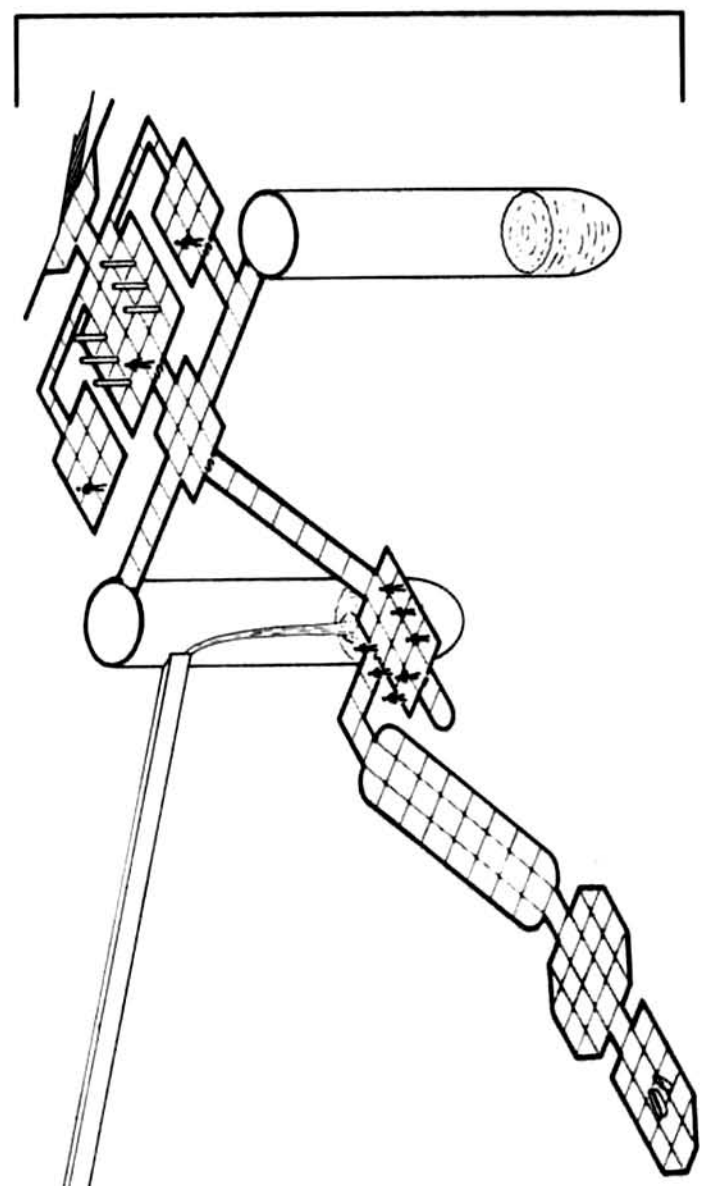

7. The Sluiceway

The wet and slimy walls of this 10-foot-diameter sluiceway slant up farther than light will reach. Water pours down from above, filling the duct more than a 18 inches deep. The air is humid and cool.

It is possible, but unlikely, that this sluiceway can be used as a passage to the Maze Level 550 feet upslope to the north. Unless magical or extraordinary means are used, ascent against the water is impossible, for the slope rises 1 foot in every 5. Footing against the water is nearly impossible, and Dexterity checks should be made regularly. Failure means that the PC is knocked down by the force of the water, tumbling down the shaft and carried along by the current. Unless given help, the PC will be carried the full length of the sluiceway and carried out the end, plunging with the water to the bottom of the East Water Storage Silo (area 6); this trip will give 2d6 damage points, and drowning will result if a Constitution check is not successful.

At the top of the sloping sluiceway, there is a cascade of water falling from above. Passing through this is a very difficult task, requiring a separate Dexterity check. If the PC makes this save, it indicates that he has passed through the cascade and climbed onto the horizontal duct leading to the Well of Questions (Kordan's Master Maze area 28). The PC will emerge from the duct beneath the platform in that room; resume play at that point.

Though this is not the way the PCs are meant to go, it is, nevertheless, possible... barely. If the players come up with some interesting and plausible way to overcome the problems, this is a way to the next level of the pyramid. Reward good play, but make the players feel they earned their reward. Remember, if it were totally impossible to use this path, it would not be here.

8. Worship Room

This 30-foot square room is accessed by 10-foot-wide arched corridors in the center of the east, south, and west walls. There are no writings on the walls and the ceiling is flat. Against the center of the north wall is a 20-foot statue of Amun-Re, formed of stone different from that of the walls.

The statue is, of course, a secret door.

9. Descending Corridor

A 10-foot wide arched corridor leads down at a moderate angle. A musty smell pervades the area and dust covers the floor.

The corridor is 70 feet long.

10. Great Worship Room

A corridor enters the south side of a large room 30 feet wide east to west and 40 feet deep north to south. Against the north wall, are three statues of Amun-Re, and against each side wall are two more. All of the statues are cut from a different kind of stone than the surrounding walls.

In the center of the room stands an altar. Impressions of a left and right hand are carved side-by-side into the front of the altar. On the ceiling and remaining walls, the name *Amun-Re* is carved over and over in several languages.

The center statue on the north wall pulls open to the right, in the manner of the other secret doors. It reveals an empty room, 10 feet wide and 20 feet deep. This room once contained a sleeping gas, but the trap was sprung long ago.

If a PC puts his hands into the altar impressions and says "Amun-Re," the wizard locked statue that is southernmost on the east wall will swing free to reveal a corridor 10 feet wide by 30 feet long, with a turn to the left in the last 10 feet.

All of the other statues are cemented to the wall and will not budge.

11. Grand Hallway

This hallway slopes down at a moderate angle. Axe and hammer marks cover the walls. The plaster from the great frescos that once covered these walls has fallen to rubble on the sloping floor. Dust blankets everything, and the air is very dry.

This hallway is 80 feet long. A broken door will be found at the far north end.

12. Treasure Room

Beyond the broken door is a huge octagonal room, 50 feet wide, 40 feet long and 20 feet tall, rising to a flat ceiling. In the center of the north wall, an arched corridor leads to the north.

The words *Treasure Room* are carved into the walls in giant letters and several languages. Scattered about the room are broken pots and chests that have been hewn in half. All are covered with a thick layer of dust.

A dwarf would feel that the room is slightly below ground level. It is, of course, no treasure room at all, but part of the elaborate hoax.

13. The Tomb Room

This room is 30 feet wide, disappearing into the darkness. In the center of this 20-foot tall room sits the sarcophagus... a large, ornate, stone coffin. Its lid is ajar and broken. In the center of the north wall, ancient writing has been chiseled into the stone.

The sarcophagus contains nothing but dust, not at all unusual, for it is not Amun-Re's tomb at all. The inscription, which is reproduced as Inscription 8N on the reverse of the DM's fold-up map, reads as follows:

Here lies the true tomb of Amun-Re.
Know that ye have arrived too late to
plunder my ransom for heaven's gate.

Kordan's Master Maze Level Encounter Areas

For play in the Maze Level of the Tomb of Amun-Re, refer to Map 8-3 in the *Map Booklet*. The Encounter Areas on this level are arranged as though the PCs were teleported to the level; if this is the case, go immediately to the Welcome Room (area 1). If they arrived here via the sluiceway, go immediately to the Well of Questions (area 28).

The maze contains areas that are identical in every respect; only one description is provided, and the maps are keyed accordingly.

Maze Level Random Encounters

Check for an encounter every three game turns. An encounter will occur on a roll of 1 on 1d6. Roll 1d12 to determine which encounter to use from the Maze Random Encounter Table.

Maze Random Encounter Table

1. Wizard: AC 9; MV 12"; MU 6; hp 17; #AT 1; D 1d4; AL NG. He can use these spells at sixth level: *charm person*, *comprehend languages*, *featherfall*, *magic missile*, *continual light*, *web*, *fireball*, *Leomund's tiny hut*. He stumbled in here some time ago looking for magical items. If he is encountered a second time, re-roll for another encounter.
- 2-4. 1-3 Minotaurs: AC 6; MV 12"; HD 5 + 3; 35, 29, 37, 25, 26, 30; #AT 2; D 2d4 (butt) or 1d4 (bite)/1d8 (axe); AL CE.
- 2-3. Roll to determine how many are present, then use the hp given above. When one dies, remove it from the list here and in the Minotaur Lair (area 25).
- 5-6. 1-3 Doppelgangers: AC 5; MV 9"; HD 4;

hp 20, 18, 15; #AT 1; D 1d12; AL N. Roll to determine how many are present, then use the hp given above. When one dies, remove it from the list here and in the Grieving Elves room (area 24). The dopplegangers will take the form of their last victims as a disguise, donning their garb to help the illusion. Roll 1d6 and consult the Doppelganger Appearance Table below to determine their appearance.

Doppelganger Appearance Table

1. Fighter Elves in glistening chainmail.
2. Dirty and cagey dwarven knights, wise to the ways of the tomb.
3. Pious clerical men on the quest to free the curse.
4. Wizard men come to discover the secrets of Kordan the Archmage (The dopplegangers will not actually have magical abilities, although they will pretend to possess them.)
5. Jolly halfling thieves on an outing.
6. Haggard rangers of few words and many actions . . . or many words and few actions.
7. 1d6 Sharpers: AC 7; MV 12"; T 3; #AT 1; D 1d6; AL NE.
- 8-9. 1d6 Dervishes: AC 6; MV 12"; F 4; #AT 1; D 1d8+2; AL LN. These are members of the dervish party that have become separated from their leader and have wandered around in the maze. They will join the PCs if asked, but will respond as typical dervishes to any desecration or plundering of this tomb. They came to offer themselves as sacrifices on the altar of Amun-Re. The East Offering Temple (Plundered Tomb Level area 4) seemed to offer the best way. They were teleported here and have been wandering ever since.
10. 10 Ghouls: AC 6; MV 9"; HD 2; #AT 3; D 1-3/1-3/1d6 (claw/claw/bite); AL CE; save vs. paralysis when touched or else be paralyzed.
11. 1d4 Cutpurses: AC 6; MV 12"; T 4; #AT 1; D 1d6; AL CE.
12. Giant Spiders (3) (AC 4; MV 3"/"12"; HD 4+4; #AT 1; D 2d4 + poison; AL CE.

1. Welcome Room

Read both boxed descriptions *only* if the PCs arrive via the teleport. Otherwise go immediately to the second description.

As soon as you are fully within the offering basin, the flames rise up before you completely blocking your sight. You are blinded momentarily, and you feel a slight dizziness, which passes almost as soon as it began. When you look up, however, you are in the basin no longer.

This room is a perfect octagon with four arched exits, a domed ceiling, and a prone human skeleton in the center of the floor. A vaguely sulfurous smell assails the nostrils.

The room is 30 feet wide from side to side, and the ceiling is 30 feet tall. The exits are all identical and separated from one another by identical walls; walls and exits are about 10 feet wide.

Rust-orange mists swirl on the other side of the archways, clearly visible from anywhere in the room. A lever is set in the center of each wall, just above an inscription that says *Pull Me* in several languages; the levers obviously pull upwards. The skeleton lies in the center of the floor, its arm extended above its head; it holds a sword in this arm, the point indicating one of the exits.

If the players have just entered this level via the teleport, they will be disoriented. Though they faced north when they entered the offering



bowl, they arrive in the center of the room facing south, the skeleton nearly at their feet. They thus will *not* know one direction from another. It is necessary, therefore, to give directions only in terms of *left, right, ahead, behind*, and not using compass points. This is emphasized in the section on *Expected Play*.

The skeleton's sword points toward the west exit. There is no significance to this.

If a PC lifts any lever, a powerful magnetic field will activate in the dome. This will lift loose iron to the ceiling, and has a chance to pull away helmets, gauntlets, and weapons made of iron or steel. Metal armor will be drawn up as well, whether or not it is being

worn. If it is in a backpack, the pack will lift the PC carrying it up until a strap breaks; give 1d6 points of falling damage. If a PC is wearing chain, banded leather, splint, or plate armor, he will be drawn up to the ceiling; this will give 1d8 damage points as the PC slams into the dome. If a PC is wearing greaves, he will be swept off his feet, but will not be drawn upward, though his legs will be.

The magnetic field will remain in effect until all of the levers are pulled down once again. Those stuck to the dome when the field is turned off will, naturally, fall 30 feet to the floor, taking 3d6 damage points unless other precautions have been taken. Those on the ground will take damage from falling objects (and persons), unless they get out of the way.

2. Kordan's Master Mists

This area is not numbered on the map, but is coded graphically instead. One such area is identical to another. Read the boxed description the first time the PCs step into the mists.

The mists are a swirling rust-orange color, dry and warm; they smell vaguely sulfurous. Entering them seems to present no problem, except that they obscure everything. Even bright lights become a diffuse haze, and it is literally impossible to see one's hand 6 inches in front of one's eyes.

After a short time, you feel slightly light-headed; the sulfurous smell seems to have disappeared. Your mind wanders; you have a difficult time counting paces as you walk, and you lose count frequently. All distance sense is gone with your sight, though your sense of touch seems strangely unimpaired.

The mists cause disorientation to PCs in them. They have no permanent effects, and the disorientation disappears instantly when the PCs enter a clear area. All warm-blooded creatures passing through the mists will leave heat traces detectable with infravision for one full turn.

While in the mists, the PCs cannot see. Nor may they count steps to determine distance. Walking together, one or another might forget momentarily where they are going and what they are to do. Use these properties as a problem that the players must solve. If they make no attempt to do so, just keep track of where they are; they might wander for hours of game time. If, however, they make attempts to solve the distance and sight problems, give them enough successes to keep their interest up.

For example, the corners are all rounded, both the outside and the inside curves. Because of the disorientation, a single person feeling his way along a wall would not notice the curve. Nevertheless, should that person put his back to the wall at a corner and extend his arms horizontally, touching the wall with his palms, he will be able to *feel* the difference between the

two sides. At an inside curve, his arms will be bent backward; at an outside curve, his arms will be somewhat in front of him. Similarly, if 4 PCs walk abreast in the mist and they come to a corner, the PC at the outside will have to hurry to catch up, whereas the person at the inside will seem to rush ahead. If the PCs send one with a rope ahead, they can send rope signals. They even can use the rope to distinguish total distance between one clear area and another.

It is clues like these that will help the players solve the problem of determining where they are. Be sure to reward good play, stretching a point a bit if necessary to do so. Wondering monsters will take their toll when bad play results.

3. Standard 30-Foot Corridor

The mists part to reveal a 10-foot by 30-foot section of clear corridor with mists filling the archways at both ends. Archways lead out from the center of both side walls and are also filled with mists.

4. Standard Plank Door 1

The mists part to reveal a 10-foot square section of clear corridor. The mists fill the archway to the rear, and a heavy door bars passage ahead.

5. Six Bags Full

The mists part to reveal a 10-foot by 30-foot section of clear corridor with mists filling the archways at both ends. Archways lead out from the center of both side walls and are also filled with mists. Six small, leather sacks lie in the center of the corridor.

The sacks contain 510 gp.

6. Door Hammer

You are in a 10-foot square section of clear corridor with the mists filling the archway at one end and a heavy plank door at the other. A hammer lies by the door.

This is a *hammer +1*.

7. Silver Ringer

The mists part to reveal a 10-foot by 30-foot section of clear corridor with mists filling the archways at both ends. Archways lead out from the center of both side walls

and are also filled with mists. On the floor in the center of the area is a ring that appears to be made of fine silver.

There is a base chance of 20% for PCs to detect a fresh breeze from the north exit. Following this breeze will lead to a way to the next level.

The ring is a *ring of contrariness*; it also confers the ability to fly, as in the 3rd level spell *fly*. The ring will not come off until a *remove curse* is cast upon the wearer, an event that the wearer will resist with every power available.

8. Breezeway

The mists part to reveal a 10-foot square clear intersection of four archways, each filled with swirling rust-colored mists.

There is a base chance of 40% for PCs to detect a cool, fresh breeze from the east exit. This leads to the Well of Questions (area 28), a way to the next level.

9. Knock, Knock

The mists part to reveal a 10-foot square section of clear corridor. Mist fills the archway to the rear, and a heavy plank door bars the way ahead. On the door, in common speech is written "Knock First."

The sign is to alert the bandits inside that there are foolish adventures about to come in.

10. Standard Plank Door 2

The mists part to reveal a 10-foot square clear intersection of archways. Three archways are filled with the rust-colored mists, and the fourth is blocked by a heavy wooden door.

11. Drafty Door

The mists part to reveal a 10-foot square section of clear corridor. Mists fill the archway behind, and a heavy wooden door bars passage ahead. A fresh, cool breeze flows out from under the door.

The sounds of tumbling torrents of water will be heard if listening at the door is successful.

12. A Bad Smell 1

The mists part to reveal a 10-foot by 30-foot section of clear corridor with mists filling the archways at both ends. Archways

lead out from the center of both walls and are also filled with mists.

The stench of carrion can be detected from the south exit 10% of the time.

13. A Bad Smell 2

The mists part to reveal a 10-foot by 30-foot section of clear corridor with mists filling the archways at both ends. Archways lead out from the center of both side walls and are also filled with mists.

The stench of carrion can be detected from the north exit 10% of the time.

14. Treasure Sled

The mists part to reveal a 10-foot by 30-foot section of clear corridor with mists filling the archways at both ends. Archways lead out from the center of both side walls and are also filled with mists. Lying on the floor in the center is the skeleton of a person who seems to have died while pulling a sled. The sled holds three chests, two on the bottom row with the third on top of them.

There is a base 20% chance for PCs to detect the stench of carrion from the north exit. The skeleton is harmless.

When the top chest is opened, it shoots out drug-tipped darts in an arc ranging from straight up to directly in front of the chest. All PCs directly in front of the box must make a successful dexterity check or be hit by some of the darts. Anyone hit must save vs. poison or be paralyzed for 1d20 turns. The chest now contains only old, used, orc socks and the trap mechanism. The bottom two chests each contain 500 gp, loose.

15. Carnage

The mists part to reveal a T-shaped intersection. Strewn all about are bodies in various states of decay; all died in battle. In the center of the area, a body lies on its back, spit-ted through by a brightly shining sword that sticks into the stone floor. Each branch of the intersection is 10 feet long and disappears into the rust-orange mists.

The shining sword is the only usable piece of equipment to be found among the bodies in the room. A careful examination of the sword will reveal the word *Enduval* inscribed on the blade near the hilt. *Enduval* is a cursed berserking sword. When first used in combat, it forces its user to attack the nearest person to him, friend or foe. The bearer must continue attacking

until either his opponent or he is killed. For the duration of this attack only, the sword gives a magical bonus of +2 to hit. Only an *exorcise* or *wish* spell will allow the PC who picks up Enduval to rid himself of this device.

16. A Bad Smell 3

The mists part to reveal a 10-foot by 30-foot section of clear corridor with mists filling the archways at both ends. Archways that lead out from the center of both side walls are also filled with mists.

There is a base chance of 20% for PCs to detect the stench of carrion from the south exit.

17. A Bad Smell 4

The mists part to reveal a 10-foot by 30-foot section of clear corridor with mists filling the archways at both ends. Archways lead out from the center of both side walls and are also filled with mists.

The stench of carrion can be detected from the west exit 20% of the time.

18. Door and Smell

The mists part to reveal a 10-foot square clear intersection of archways. Three archways are filled with the rust-colored mists, and the fourth is blocked by a heavy wooden door.

There is a 10% chance of detecting a carrion stench from the west exit.

19. Knapsack at the Door

In a 10-foot square section of clear corridor, the mists fill the archway behind, and a heavy plank door blocks the way ahead. A leather knapsack lies on the floor next to the door.

Within the knapsack there are two scrolls and 5 leather pouches. Written by a 6th-level magic user, one scroll has a *fly* spell and the other a *fireball* spell. The leather pouches contain 1,000 gp.

20. Silver Ring

The mists part to reveal a 10-foot by 30-foot section of clear corridor with mists filling the archways at both ends. Archways lead out from the center of both side walls and are also filled with mists. A bright silver ring sits on the floor in the center of the area.

It is a *ring of protection* +3.

21. Trail of Gold

The mists part to reveal a 10-foot by 30-foot section of clear corridor with mists filling the archways at both ends. Archways lead out from the center of both side walls and are also filled with mists. From one end of the area, a ragged trail of gold pieces leads down to the intersection, turns sharply, and disappears into the mists.

The trail starts at the east end of this clear section of corridor and leads to the north archway, where it ends. There are no coins to be found in the mists. The value of the coins is 137 gp.

22. Platinum Path

The mists part to reveal a 10-foot by 30-foot section of clear corridor with mists filling the archways at both ends. Archways lead out from the center of both side walls and are also filled with mists. A trail of platinum pieces starts in the center of the corridor and runs to the far end, into the mists.

The trail of platinum starts in the center of the area and leads into the mists of the west exit. The total value of the coins is 152 gp.

23. Standard T-Intersection

The mists part to reveal a T-shaped intersection. Each branch is 10 feet long and ends in rust-orange mists.

24. Grieving Elves

The door opens to reveal a 30-foot-square room with 10-foot walls rising to a flat ceiling. Bones litter the floor. Standing about the room, mourning over the bones, are (see below for number) elves in adventuring garb. There is a plank door in the center of each wall; otherwise, the walls are smooth and unmarked.

The figures are not elves but doppelgangers who have formed themselves into the image of the victims they destroyed in order to fool and join another group. If the party has encountered and slain the 3 doppelgangers as a random encounter, there will be two monsters here; otherwise there will be 5.

The monsters will claim to be elves grieving over their long-lost brethren whose bones they just found. They will be friendly, attempting to join up with the party, maintaining their illu-

sions until it becomes advantageous for them to change.

They will attempt to lead individual party members away from the rest of their comrades, where they will attempt to destroy the hapless soul and take his place in the party. They will use their ability to read minds in carrying off the sham. The doppelgangers will continue this process until the whole party is destroyed or the doppelgangers themselves are all dead. As one of their ploys, they will also claim to know their way through the maze. The trick, they will claim, is first to send two people through the mists with a rope for the others to follow. They will gladly demonstrate by sending one of themselves and a party member.

If the party behaves in an unfriendly manner, the doppelgangers will leave reluctantly, but peacefully. After all, they know where there is food, and they will hang around as wandering monsters until they are dead. All random encounters will be with the surviving doppelgangers until they are all dead. Use the Doppelganger Appearance Table to determine their appearance and demeanor.

Doppelgangers: AC 5; MV 9"; HD 4; hp 28,30 (20,18,15); #AT 1; D 1d12; AL N. As described above, there may be either 2 or 5 monsters here.

25. Minotaur Lair

The heavy planked door opens onto a 30-foot-square room with 10-foot walls rising to a flat ceiling. There is a door in the center of each wall. In the center of the ceiling is a 10-foot diameter hole. This is the bottom of what appears to be a circular shaft. From a large pile of straw directly under the shaft, rise (see below for number) hulking shapes. They have the heads of bulls, and they bear battleaxes, which they brandish as they move rapidly toward the door.

A total of 7 minotaurs have their lair here. As many as 6 of these are wandering the maze and are likely to have been encountered as random wandering monsters. As stated in the section on *Expected Play*, reduce the number of minotaurs as they are encountered and killed. If, when the PCs arrive here, there are 3 minotaurs left, they will be encountered here. If there are fewer, use as many as are left; there will always be at least one minotaur here.

There are 4,500 gp scattered about under the straw. Above the straw pile is a shaft that extends upward 30 feet above the ceiling. A heavy wooden trap door closes the shaft's upper end; it swings open downward. There is a base chance of 10% to open the door from this side, with thieves adding their *pick locks* chance to this.

The difficulty will come in avoiding the swinging door as it opens. Anyone in the shaft at the top when this happens will take 1d4 damage points from the falling door, and need to make a successful dexterity check to remain in the shaft. PCs dislodged from the shaft will take 1d6 points of falling damage unless the straw has been moved, when the damage will be 3d6 points. Opening the trapdoor from a totally safe position can only be done magically or by a thief at a penalty of -20% to his *pick locks* chance.

The open shaft leads straight up through the ceiling onto the platform in front of the statue of in room L52. See the diagram on page 23.

Minotaurs: AC 6; MV 12"; HD 5+3; hp 40 (35,29,37,25,26,30); #AT 2; D 2d4 (butt) or 1d4 (bite)/1d8 (axe); AL CE.

26. Who's There?

The door opens to reveal a 30-foot-square room with 30-foot vertical walls capped by a domed ceiling.

If the PCs knock on the door before entering, the 9 bandits within will already have scrambled to their feet and be ready to do battle. If there is no knock, roll for surprise as usual. There are several dark human forms in the room.

If the PCs have knocked on the door previous to opening it, the monsters inside will be

prepared for their entry, otherwise roll for surprise as normal.

Sweaty and dirty, nine bandits are resting. These fellows were searching for treasure, but now are only interested in finding their way out. They will join the party meekly if the way out is offered to them. If, however, they get one look at any treasure worth 500 gp or more while in the company of the party, they will attack at once.

Bandits: AC 6; MV 12"; F 2; hp 14,12,10,13,15,11,14,12,12.; #AT 1; D by weapon; AL CE.

27. Trap Room

In the center of this 30-foot-square room stands a chest. The 30-foot-high vertical walls capped by a domed ceiling.

The chest is not real, but is a part of a hungry trapper that will attack the first person who walks onto its surface. Victims caught in the trapper may not attack it and will suffocate within six rounds. PCs can distinguish trappers from the floor only 5% of the time.

Trapper: AC 3; MV 3"; HD 12; hp 44; #AT 1; D 4 + AC of victim; AL N.

28. Well of Questions

Read the following *only* if the PCs climbed the

sluiceway.

After the rugged passage up the sluiceway and the tremendous pounding given by the cascade, travel along the horizontal duct is very easy. After 10 feet or so, it opens onto a 3-foot wide channel 3 feet deep. Water pours from a pool 10 feet from the beginning of the channel.

Read the following when the PCs enter the room proper.

In the center of this 30-foot-square room, a circular well 10 feet in diameter surges with clear water. The 30-foot vertical walls rise to a flat ceiling. On opposite sides of the room are a platform and the door. A large figure lies prone upon the platform, its deep brown eyes glaring at the intrusion.

Water rushes at an enormous rate from the well into a channel in the floor. This channel is 3 feet wide by 3 feet deep and leads to a large circular opening under the platform.

The water is Water of Athis; it wells up, flows rapidly down the chute, into the duct, and down the sluiceway, emptying out in the West Water Storage Silo (Plundered Tomb Level area 6). PCs walking or falling into the fast-moving water must make a successful dexterity check or be swept into the duct and down the sluiceway; should this occur, there is a chance of drowning (see Plundered Tomb Level area 7).

Looking into the well, a PC would see a 10-foot-diameter underwater tunnel that enters the well from the east side. Water flows into the well through this tunnel, which is the bottom of the Waterway (Priesthood Halls Level area 1). Though the volume of water is high, the well's large size makes the current slow and swimmable. See the illustration for a cross-section of this room, including the waterways into and out of it.

The prone figure is an androsphinx, who initially will be fairly friendly, asking what the PCs are doing here. Then he will offer to play the riddle game with them. If the PCs can answer his riddle, he, in turn, will answer any one question they have about the tomb; if, however, they cannot answer correctly, he will attempt to eat them. He thinks this is perfectly fair, and is smugly content with his proposition. Though his knowledge of the tomb is limited, his hunger is not.

The DM is free to ask any riddle he chooses, keeping in mind that the original sphinx question, "What walks on four legs in the morning, etc." will be used in another dungeon. A suggested riddle is:

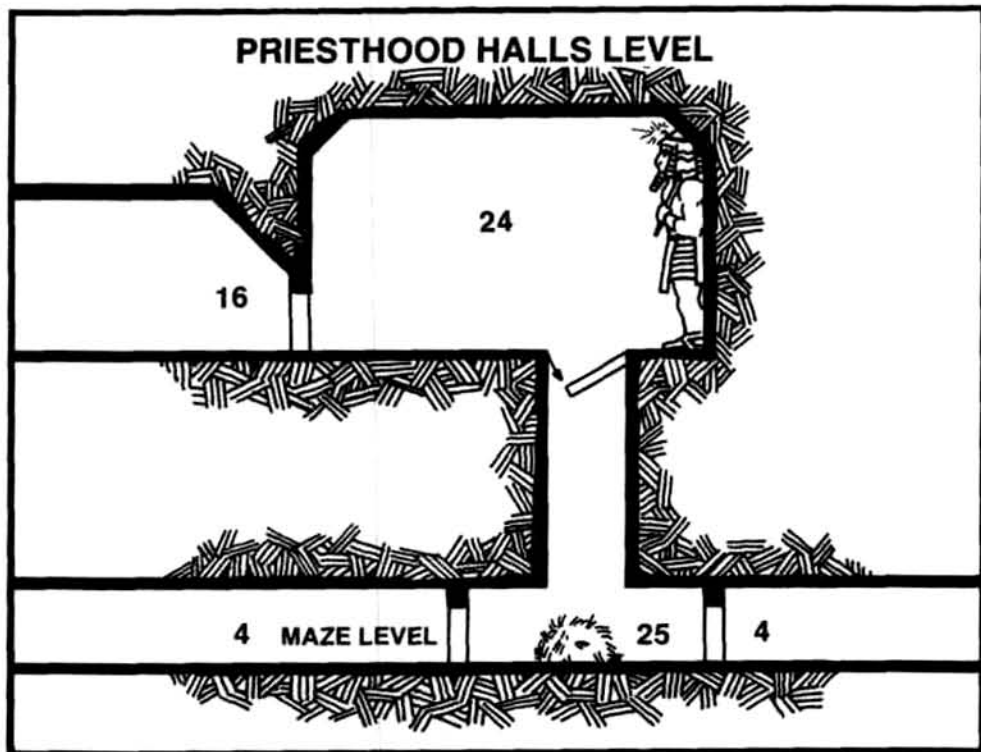

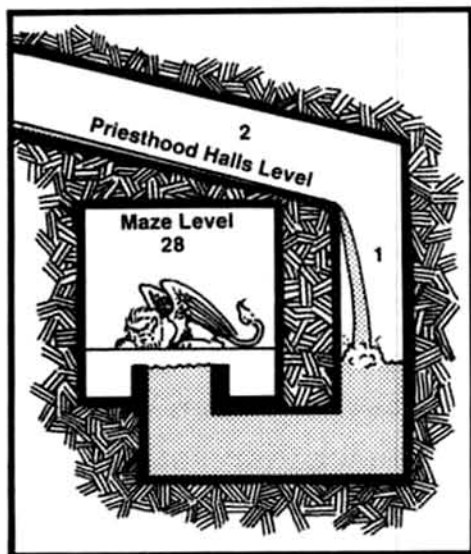

All of the people who live in the east side of Bindon tell the truth all of the time. All of the people who live on the west side never tell the truth. During the day, when both east-and west-siders mingle in the shops and streets of either end of town, it is impossible to tell one from the other by appearance alone. If you get lost in Bindon, what one question could you ask that would tell you correctly which side of town you were on?

For this riddle, the question to ask is "Do you live here?" If the answer is "yes," you will be on the east side, for the east-siders will answer truthfully and the west-siders will lie. If the answer is "no," then you will be on the west side for the same reason.

If the PCs agree to play the game, the sphinx will be friendly until he gets a wrong answer. Then he will attack immediately, believing that only people who belong here would know the answer to his riddle. If the riddle is answered successfully and he is forced to answer a question about the tomb, the sphinx might lie; there is a base 30% chance minus the Charisma of the asking PC that this will occur. In any event, he only knows about the maze and the entrances to the next level up. He knows that the only way out of the tomb from this level is down the sluiceway, but that it is unsafe. He knows nothing about the rest of the tomb's interior.

Androsphinx: AC -2; MV 18"; HD 12; hp 40; #AT 2; D 2d12/2d12; AL CG; also attacks with a roar.

29. Javelins

On the far side of this 30-foot-square room, an open chest displaying hundreds of platinum pieces. Pinned to the left-hand wall by steel spears are four skeletons. The right wall is covered with an intricately carved wooden grill. A 3-foot wide ledge runs around the base of the domed ceiling 30 feet above the floor.

The grill covers a honeycomb of 1-inch holes each containing a spear and a charge of compressed air held in place by a spell. Anything that passes in front of the holes will discharge the spell, releasing the compressed air and hurling the spear across the room with great force. Of the original 50 spears, only 46 remain active.

The spears have a base 4 to hit a PC passing before them; add 2 for every point of Dexterity the passing PC has over 15. If hit by a spear, the PC will be pinned to the opposite wall by the force of the impact, giving 1d10 damage points. For each round the PC is hung on the wall give an additional 1d4 damage. Pinned PCs may not free themselves but may be freed by others with a combined total of 15 strength points.

The chest contains 500 pp. The domed ceiling and the ledge just below it form an Observation Room (Priesthood Halls Level area 25) where the priests used to watch plundering thieves meet their death. A concealed door in the dome wall leads from the ledge to a dark, dusty corridor. Continue play using the map and key to the *Halls of the Upper Priesthood*.

30. X-room

Carved on the floor in the center of this 30-foot-square room is a giant "X". The room's 30-foot walls rise to a domed ceiling. A 3-foot-wide ledge runs around the base of the dome.

Any weight in excess of 40 pounds (400 gp weight) on the "X" will trigger a trap. Concealed in the dome directly above the "X", a 10-foot-square by 4-foot-tall, empty stone box will drop. Anyone within 5 feet of the center of the "X" must make a successful Dexterity check or take 2d8 damage points from the crashing box.

The domed ceiling and the ledge just below it form an Observation Room (Priesthood Halls Level area 26) where the priests used to watch plundering thieves meet their death. A concealed door in the dome wall leads from the ledge to a dark, dusty corridor. Continue play using the map and key to the *Halls of the Upper Priesthood*.

31. Pendulum

Hanging motionless from a pendulum pole in this 30-foot-square room is a scything blade, edge to the door. The pendulum hangs from the domed ceiling above and is attached to the center of the wall opposite the door. There is a 3-foot wide ledge running around the base of the dome, 30 feet above the floor.

If the rope holding the pendulum is cut or untied, the blade will swing out towards the door, then back again, and back and forth. Each swing will be slightly shorter until after five rounds, when it will come to a complete stop in the center of the room. Anyone standing directly in line with the door when the blade is swinging must make a successful Dexterity check or take 1d10 damage points.

The domed ceiling and the ledge just below it form an Observation Room (Priesthood Halls Level area 27) where the priests used to watch plundering thieves meet their death. A concealed door in the dome wall leads from the ledge to a dark, dusty corridor. Continue play using the map and key to the *Halls of the Upper Priesthood*.

32. Dervish Explorers

The door opens to reveal a 30-foot square room with 30-foot walls rising to a domed ceiling. Six desert-garbed figures are lying about the room.

This room contains the dervish leader that entered the tomb and got lost; five members of his band are with him, the remainder being still lost in the maze. They are tending their wounds. Three of their comrades lie dead in the far corner. Three more wander the Priesthood Halls Level above, having been sent there to scout from the Extra Trap Room (area 36).

When the door opens, the dervishes will jump up as if to attack, but they will hesitate unless the PCs act hostile. If the PCs attack the dervishes, however, they will fight; if not, the dervish leader and his men will be overjoyed to see new faces. If asked, the dervishes will join the PCs, but they will continue to act as typical dervishes with regard to plundering or desecration of the tomb.

5 Dervishes: AC 6; MV 12"; F 4; hp 20 each; #AT 1; D 1d8+2; AL LN.

33. Robber Press

The door opens easily into an empty 30-foot-square room. The door remains open, seemingly on its own. The walls of the

room are 30 feet tall, and the ceiling is capped by a dome.

The whole room is a trap, triggered by weight on the center 10-foot square portion of the floor. If anything over 40 pounds (400 gp weight) comes to rest on this area of the floor, the trap will spring. The door will slam shut and latch (+2 on rolls to open the door from either side) and the walls on the east and west will begin to close in.

These walls are an irresistible force and take one round to come to striking distance. At that point, anyone caught between the walls will be unable to move and will sustain 2d10 damage points per round they are caught. The walls remain together for 3 rounds and then move back. When the walls have moved back, the door will open easily again.

34. Old Trap Room

The door opens onto an empty 30-foot-square room. The walls are 30 feet tall, and the ceiling is capped by a dome.

You can put a trap here if you like, but it is not necessary. The pyramid architects had one here, but it broke and they couldn't get a replacement part in time, so they dismantled it.

35. Pole Forest

In this 30-foot-square room, spears thrust from the floor to the top of the domed ceiling. The skeletal remains of a dwarf in banded armor is pinned to the dome by several of the spears; even his carrying bag is stuck clear through.

The shafts are 1.5 inches in diameter and spaced about 6 inches apart. Through the spears, the glint of jewels can be seen some 15 feet away on the floor, apparently spilled from the carrying bag overhead.

The walls are 30 feet tall and are capped by a dome. A 3-foot-wide ledge runs around the base of the dome.

Spilled amid the poles here are several worthless gems and five jewels worth 1,000gp each. If the PCs want to take the treasure, they must first get to it. If they decide to hack and saw at the spears, they will spend 2d4 turns doing this. It will be a noisy process, requiring a wandering monster roll every turn that the party continues cutting and sawing the poles.

If, however, they decide to burn the poles, the fire will cause a great amount of smoke for 1d6 turns. During this time, the PCs must leave the area or suffer 1d4 damage points per turn. The smoke will also require a roll for attracting a wandering monster every turn.

The domed ceiling and the ledge just below it form an Observation Room (Priesthood Halls Level area 28) where the priests used to watch plundering thieves meet their death. A concealed door in the dome wall leads from the ledge to a dark, dusty corridor. Continue play using the map and key to the *Halls of the Upper Priesthood*.

36. Extra Trap Room

The door opens onto an empty 30-foot-square room. The walls are 30 feet tall, and the ceiling is capped by a dome.

You should put your favorite trap in this room. Do not make it too deadly, however.

The domed ceiling and the ledge just below it form an Observation Room (Priesthood Halls Level area 29) where the priests used to watch plundering thieves meet their death. A concealed door in the dome wall leads from the ledge to a dark, dusty corridor. Continue play using the map and key to the *Halls of the Upper Priesthood*.

37. Loose Ceiling

The door opens onto an empty 30-foot-square room. The walls are 30 feet tall, and the ceiling is capped by a dome.

The first PC entering the room will be attacked by the lurker above living in the dome. The lurker above will smother its prey in 1d4+1 rounds.

The domed ceiling and the ledge just below it form an Observation Room (Priesthood Halls Level area 30) where the priests used to watch plundering thieves meet their death. A concealed door in the dome wall leads from the ledge to a dark, dusty corridor. Continue play using the map and key to the *Halls of the Upper Priesthood*.

Lurker Above: AC 6; MV 1"/9"; HD 10; hp 40; #AT 1; D 1d6; AL N.

Halls of the Upper Priesthood Level Encounter Areas

For play in the Halls of the Upper Priesthood Level, refer to Map 8-4 and the appropriate inscriptions on the reverse of the DM's fold-up map. To get onto this level, the PCs may have entered via one of the concealed doors in the Observation Domes (areas 25-30) or climbed up the Waterway (area 1). The encounter areas are arranged as though the PCs entered via the Waterway.

There are compass roses at all of the

entrances to this level. This will allow you and your players to use the more convenient compass directions again.

The waterfall, pool, and aqueduct stream all contain Waters of Athis; this water will heal 1d10 damage points on anyone who has not drunk of it within 24 hours.

Priesthood Halls Random Encounters

While the PCs are in the Priesthood Halls, check for random encounters once every 3 game turns. A roll of 1 on 1d6 indicates that an encounter takes place. If an encounter is indicated, roll 1d12 to determine which encounter to use from the Random Encounter Table.

Priesthood Halls Random Encounter Table

1. Knight: AC 2; MV 12"; F 5; hp 5 of 40; #AT 1; D 1d8+2; AL LG. The knight will join the party willingly. He is dazed and remembers little, having arrived here by accident after a fall into the West Water Storage Vault. His recollection of the tumultuous trip through the rapids, the sluiceway, and then the falls is hazy. He is still suffering its effects, having escaped drowning by a narrow margin. If he has already been encountered, re-roll ignoring this result.
2. Cleric: AC 8; MV 12"; C 5; hp 32; #AT 1; D 1d4; AL NG. The cleric is all that remains of an adventuring party that climbed up the shaft from the Minotaur Lair (Maze Level area 25). The party was trapped in the lair by the returning minotaurs. The rest of the party has been killed by the wandering undead on this level. Only luck and the cleric's skill at turning the undead has saved him. He is scared to death and will join the party if he can.
- 3-5. 1d6 Cutpurses: AC 6; MV 12"; T 4; #AT 1; D 1d6; AL CE. If the thieves get surprise or outnumber the PCs, they will attack the party. Otherwise, they will shoot one or two arrows and flee. These are the "comrades" of the bandits in Who's There (Maze Level area 26). Once all 6 have been killed off by the party, re-roll ignoring this result.
- 6-7. 1-3 Dervishes: AC 6; MV 12"; F 4; #AT 1; D 1d8+2; AL LN. There are 3 Dervishes on this level sent here by their leader in Dervish Explorers (Maze Level area 32). They want to be reunited with their leader. Once the party has gathered all three, re-roll ignoring this result.
- 8-9. Giant Spider: AC 4; MV 3"/12"; HD 4+4; #AT 1; D 2d8 + poison; AL CE. If the three spiders on this level have killed, re-roll for another encounter.

10. 1d6 Ghouls: AC 6; MV 9"; HD 2; #AT 3; D 1-3/1-3/1d6; AL CE; hit causes paralysis.

11. 1d4 Wights: AC 5; MV 12"; HD 4+3; #AT 1; D 1d4 and level drain; AL LE.

12. 1-3 Wraiths: AC 4; MV 12"/24"; HD 5+3; #AT 1; D 1d6 and drain one level; AL LE.

1. Waterway

If the characters are entering this area from the underwater tunnel from the Well of Questions (Maze Level area 28), read the first boxed description to the players. If they enter this area from the Entry (area 2), use the second boxed description. See the *Map Booklet* for a cross-section view of this area.

You surface in a tumbling, turbulent pool of water. Damp darkness filled with a thunderous roar surrounds you, as a waterfall pours down into the pool. You are in a 10-foot-square shaft that rises 40 feet from the surface of the water. The water in the pool is 10 feet deep. The water falls from a 10-foot-wide archway that is set in near the top of one side of the shaft. A dim light shines through the archway. The walls of the shaft are covered with slimy green moss.

The corridor suddenly ends. The water falls over the end of the corridor through an archway into a murky pool at the bottom of a 10-foot-square shaft. It is 30 feet to the surface of the pool below. Slimy green moss covers the walls of the shaft.

Though the volume of water is great, the tunnel's large size makes the current in the tunnel slow and swimmable, although not in plate armor, of course. The moss is harmless. Hand and foot-holds are easily found in the jagged stone walls.

2. Entry

On the floor of this 10-foot-wide arched corridor, a compass rose has been clearly carved. A 4-foot-wide aqueduct carries rushing water at a tremendous rate down the 70-foot length of the corridor. This water enters from the south at the west end of the hall, where it surges high as it makes the turn. It exits through a dark archway to the east.

There is a 6-foot-wide walkway next to the aqueduct on the south side of the hall. A light shines from around the southern turn at the west end of the corridor.

3. The Long Hall

This 10-foot-wide corridor has a 6-foot-walkway beside a 4-foot-wide aqueduct. The whole corridor rises at a moderate angle from the north to south. The entire length is lit by bright light streaming in from a room at the southern end of the corridor. The water enters from the south, rushes down the aqueduct, and climbs the west wall before it disappears to the east.

4. Garden Hall

Down the center of this brilliantly lit, 30-foot-wide, 50-foot-long hall, a rapidly moving stream flows southward. It enters the hall via a 10-foot-wide entrance in the south wall and exits through a matching entrance in the northern wall. The domed ceiling, 30 feet above, glows brightly and gives life to lush tropical growth that chokes both sides of the stream, nearly hiding the side walls.

On each side of the stream, nearly hidden by the ferns, flowers, and palm trees, there is a bronze bowl of enormous size, 4 feet tall and 6 feet across. These appear to be filled with leafy apples, pears, oranges, mangos, and the like.

As the party approaches the bowls, the fruits will spread their leafy wings and, in a green flurry, take flight in all directions around the room. They are fruitflies, which, when resting, appear to be roundish fruit, their wings appearing to be leaves. The fruitflies will fly to the tops of the palm trees until the danger is past. They are inoffensive and will not attack.

Fruitflies are hard to surprise (roll at -2) but can be caught or shot down with missile weapons. Anyone who eats a fruitfly (which tastes just like the sweetest fruit of its apparent type) will gain +2 strength and +1 dexterity for one hour. Additional fruitflies will not grant further bonuses or duration of the effect, but, after the hour is over, eating another fruitfly will bring back the bonus. Fruitflies rot within minutes of being exposed to direct sunlight for even a moment.

Hidden against the walls by the foliage are four 10-foot-deep alcoves, two each on the west and east walls. In the southern alcove on the west wall, a secret door leads to the West Hall Intersection (area 6). A similar secret door in the southernmost eastern alcove leads to the East Hall Intersection (area 7).

50 Fruitflies: AC 5; MV 3"/20"; HD 1; hp 4 each; #AT nil; D nil; AL CN; surprise at -2.

5. Dome of Flight, Lower Level

The illustration gives a cross-sectional view of this room.

An octagonal room, 30 feet across, rises 55 feet to a brilliantly lit dome. A large waterfall cascades down the south wall from the mouth of a gigantic carved lion's head, hung just below the lip of a ledge that encircles the room 30 feet up. The water splashes into a large pool, empties into a stream, and flows through the north entrance. The splashing water is quite noisy.

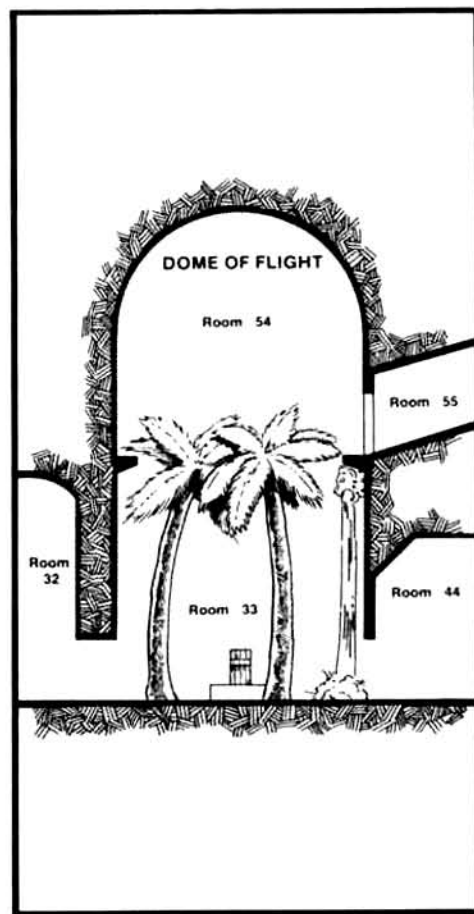

Four palm trees grow next to the pool. Their tops are nearly level with the ledge 30 feet above. Nestled in the lush greenery of their fronds are several pineapple-like fruits.

Identical granite altars stand on the east and west sides of the pool. Each altar has the impressions of a right and left hand carved into its top and golden inscriptions engraved on each face of the altars. Wooden doorways, banded with bronze, lead from the east and west walls.

The ledge, 3-5 feet wide, separates this room from the Dome of Flight, Upper Level (Gauntlet Level area 1). Its inner edge follows the octagonal shape of the room below, and its outer edge that of the circular domed room above. For further play in this area, use the map and key to the Gauntlet Level.

The 33-foot-tall trees are grenade palms, which bear fruit that look like pineapples. The fruit is explosive, a way of insuring that the seeds are scattered far enough from a tree to get the proper sunlight; the explosion does 2d8 damage points to anyone within 10 feet. If anyone walks within 5 feet of the trunk of any tree, there is a 20% chance that the vibrations of his movements will loosen one of the pineapples overhead, with a 95% chance that the grenade fruit will explode when it hits the ground. If the fruit is caught, the chance of explosion is reduced to 40%. The grenade fruit may be picked and carried, to be used later, although there is always a 10% base chance that the grenade fruit will explode whenever the character carrying them falls or otherwise bumps the fruit accidentally.

This room has the same function as an elevator. The gravity here can be altered magically, which allowed the Pharaoh's heavy sarcophagus to be lifted onto the Gauntlet Level above. The controls for the gravity reversal are on the altar. The hand impressions and speaking one of the inscriptions act as the power switch, and then the other inscriptions control the gravity by voice.

The inscriptions on the altar faces are written in the ancient alphabet. These words, which are reproduced as Inscription 80 on the reverse of the DM's fold-up map, are translated as follows, with each word having a specific effect on the gravity conditions in the room:

TURNIN LOGRA REGRA NEG

Turnin: Anyone putting his hands into the impression and saying *turnin* (turn on) will cause the hand impressions to glow and will start the magical process. Only after this is done will the other words have any effect. Once the process is turned on, anyone within the room who says one of the other words will cause its effects to take place.

Logra: Once the magic has been activated, saying *logra* (low gravity) will cause a one-tenth gravity field to fill the entire room. The PCs will feel buoyant and be able to jump 1d10 + 20 feet. The waterfall will continue to fall, but it will shoot farther out into the room, exposing the archway hidden behind it.

Regra: Once the magic has been activated, saying *regra* (reverse gravity) will cause a reverse gravity field to fill the room. The

PCs and any loose objects will fall upwards as though the room were suddenly turned upside down. The waterfall will start to flow into the dome, forming a pond and exposing an archway that was hidden behind the waterfall. Saying the command a second time will return the gravity field to its proper orientation.

If the *logra* command is used first, the PCs will float safely up into the dome. If the *logra* command is not used first, all characters must make successful dexterity checks or take 5d6 damage points as they fall to the ceiling. There is a 60% chance that 1d8 pineapple grenades will be stripped off the tops of the palms by a sudden gravity reversal; fortunately these will hit the ceiling (or floor) before the PCs do, exploding on contact.

Neg: Once the magic has been activate, saying the *neg* (negate) command aloud cancels the effects of all previous commands at once. The magical process is turned off, the hand impressions on the altars stop glowing, and spoken commands have no effect. As gravity suddenly goes back to normal, the water and anything else that is in the dome will fall to the floor. Characters on the ceiling or in the air when the process is turned off must make successful Dexterity checks or take 5d6 points of falling damage. In this case, PCs nearer the floor than the tops of the grenade palms *might* be hit by falling pineapple grenades.

6. West Hall Intersection

To the north of this intersection of 10-foot-wide arched hallways is a 10-foot-deep alcove holding a carved-stone statue. The statue, which stands on a plaster pedestal, is of a woman with a cat's head. There is a stone door 10 feet away to the east. To the west, there is a wooden door, also 10 feet away. A corridor to the south runs into darkness.

The statue is heavy but worthless. The pedestal is hollow and contains 1,500 sp. The corridor to the south is 50 feet long.

7. East Hall Intersection

To the north of this intersection of 10-foot-wide arched hallways is a 10-foot-deep alcove holding a carved-stone statue. The statue, which stands on a plaster pedestal, is of a man with a gull's head. There is a stone door 10 feet away. A corridor to the south runs into darkness.

8. West Door

This 20-foot-long hallway runs north to south. A wooden door leads from the north end to the east wall. Another wooden door leads from the south end to the west wall. There are four leather sacks on the floor.

9. East Door

This 20-foot-long hallway runs north to south. A wooden door leads from the north end of the west wall. Another wooden door leads from the south end of the east wall.

10. West Hall

A 10-foot-wide arched corridor runs east to west. In the exact center of the hall, two dark figures stand hunched over in robes, blocking the passages. A wooden door leads out of the corridor to the north of the figures. Another hallway opens to the south of the figures.

This hall is 70 feet long. Two wraiths are bent over a canvas bag containing 500 pp in the middle of the corridor. They will attack immediately.

2 Wraiths: AC 3; MV 12"/24"; HD 5+3; hp 20,16; #AT 1; D 1d6 and drain one level; AL LE; can only be hit by silver (1/2 damage) or magical (full damage) weapons.

11. East Hall

This 10-foot-wide, 70-foot-long arched corridor runs east to west. A wooden door leads out of the corridor in the center of the north wall. Another hallway leads off to the south from the center of the south wall.

12. West Kitchen

This room, obviously a kitchen, is 30 feet wide east to west and 20 feet deep north to south. The walls are 10 feet tall, and the ceiling is flat. In the center of the room, a heavy wooden block stands with a cleaver stuck into it. Large copper kettles hang on the walls. A door leads out from each end of the north wall. A single door is set in the center of the south wall.

13. West Pantry

This walls of this 30-foot by 50-foot room were once covered by frescoes of harvest grains and cattle. These, however, have col-

lapsed long ago, leaving the bare stonework of the cracked 30-foot-high walls. A wooden door is set in each end of the south wall.

14. East Kitchen

The walls of this 30-foot-wide, 20-foot-deep room are 10 feet tall, and the ceiling is flat. A dwarf skeleton, with a cleaver through its chest is lies upon a large wooden table in the center of the room. A wooden door leads from each end of the north wall. A single wooden door is set in the center of the south wall.

15. East Pantry

Empty flour sacks litter the floor of this 30-by-50-foot room, and piles of plaster line the walls where the former frescoes have been shattered. The 30-foot-tall walls are capped by a dome, cracked wide in several places at the north end. A wooden door is set into each end of the south wall. There is another wooden door in the center of the west wall.

Any character who looks closely at the cracks in the dome will see a rough-hewn tunnel rising upward from one of the larger cracks. This tunnel winds its way to Heart's Lair (Gauntlet Level area 11).

16. March of the True Faith

Writings cover the walls and ceiling of this 10-foot-wide, 20-foot-tall passage. There are two verses on the ceiling, and another eight on the walls; all are written in the ancient alphabet.

The passage is 60 feet long. There is a wooden plank door on either side of the passage, 10 feet from the north end. There is a similar set of doors 10 feet from the south end. The north entrance is blocked by a thundering waterfall. The southern end of this corridor opens into room 24.

The verses on the ceiling are reproduced as Inscriptions 8P and 8Q on the reverse of the DM's fold-up map; they are translated as follows:

8P: Above our thoughts now Master sleeps

In dreamy realms and sky so deep.
The High Priest worked a wonder great
And sealed him up unto his fate.

8Q: Great Munafik, the Priest most high

Studies his tomes that he might ply
That water path where all the great
Leave death behind and loose their fate.

The verses on the walls are reproduced as Inscriptions 8R-8Y on the reverse of the DM's fold-up map; they are translated as follows:

8R: Munafik was High Priest of Amun-Re and leader of his rites and his religion.

8S: Munafik, Priest, was keeper of the Tomes of Terbakar, the greatest library in all lands of the Golden Age.

8T: Munafik searched, too, for life eternal and some say that he sought to rob the Pharaohs of their right to that life.

8U: But through his study of all the books of secret lore, he sought only to serve.

8V: In truth, Munkfik's search was rewarded, for the books showed him the way of life eternal here.

8W: Now terrible and great in his power, he acts as the voice of Amun-Re to us.

8X: He cannot die, for his life lies elsewhere.

8Y: Munafik now is second only to Osiris himself, and he has claim on the rule of Amun-Re.

These verses were written long ago by a priest who served Munafik. Although written to please Munafik, they also tell of his evil designs. Munafik read old and wicked books to prolong his life, but the books turned him undead. In his quest to prolong the lives of the priests, he turned them into wights and wraiths. Finally, he magically placed his heart into a special jar so that he would be protected from all harm.

17. Priesthood Cells

This 40-foot-long corridor has a wooden door at each end. Ancient, rotting black drapes hide the entrance to four rooms on each side.

Each cell is 10 feet square, and full of dirt and broken cots.

18. Priest Closet

Two large sarcophagi stand facing each other across the path between two doors. Their features seem dark and blurred by time.

The sarcophagi are empty.

19. West Cell of the High Priest

Within this octagonal room, 30 feet across, a single bright figure is valiantly swinging a flashing sword at eight dark-robed figures encircling it. There is a wooden plank door in the center of the north, south, east and west walls.

A female paladin needs rescue from 8 ghouls. If she survives the fight, she will gladly join the party as long as no PC has an evil alignment. She entered here at the command of a desert spirit who begged her to plunder his tomb for him while she was on quest for a magic amulet. She does not know the way out of the tomb.

Though she does not know the way out of the tomb, she will relate the following:

"Since the lands dried up, none of the faithful were left to bring food or offerings to the temple. Soon the stored foods were gone and the priests turned to their High Priest for the answer. He taught them the dark arts, telling them that it was the way to eternal life. It turned out, however, only to be the way to eternal undeath. The priests soon turned into wraiths, wights, and ghouls, feeding on the hapless adventurers that entered the tomb."

She will relate that she managed to corner the High Priest by a waterfall not far from here. Though she made a good solid hit with her sword, it passed right through him. He laughed and said, "Fool! My life is too precious a thing to carry it with me." He then uttered a few words and flew through the air, disappearing into the dome above. She does know the way from here to the waterfall in the Dome of Flight (area 5).

Paladin (female): AC 4; MV 12"; P 6; hp 24 left of 48; #AT 1; D 1d6; AL LG.

8 Ghouls: AC 6; MV 9"; HD 2; hp 12,10,12,5,6,6,10,3; #AT 3; D 1-3/1-3/1d6 + paralyzation; AL CE.

20. Priest Catacombs

A huge room, greater than the extent of the light, extends into the darkness. In its center, a giant block of black stone sits, its vertical walls covered with upright sarcophagi. The faces that were carved into the coffin lids have been gouged out by deep claw marks. Four wooden doors lead into this room, two on the east wall, and two on the west wall; each door is 10 feet from the nearest corner.

This room is 60 feet long north to south and 40 feet wide east to west. The stone block is 20 feet wide by 40 feet long. There are 12 sarcophagi lining its walls. There are two on both the north and south ends and four on either side. Each sarcophagus opens into the hollow center of the block where 6 ghouls live. They will attack as soon as any sarcophagus lid is opened.

6 Ghouls: AC 6; MV 9"; HD 2; hp 8,11,11,12,6,8; #AT 3; D 1-3/1-3/1d6 + paralyzation; AL CE.

21. Priest Closet

At each end of this 10-foot-wide, 20-foot-long room, a sarcophagus faces toward the center. The carved features on the sarcophagi seem dark and terrible. Two wooden doors face each other from the center of the east and west walls.

The southern sarcophagus conceals a secret door that leads to a 10-foot-wide by 20-foot-long dead-end. The other one contains a skeleton which will fall out of the sarcophagus when it is opened.

22. East High Priest's Cell

In the center of this octagonal room, which is 30 feet across, are three robed figures. They squat in a circle, muttering to themselves. There is a wooden plank door in the center of the north, south, east and west walls.

Three wraiths are grouped around an object on the floor. They block the PCs' from seeing a sword that shines and hums softly. The sword is Bar-ethel (True Death), a sword +1, +4 vs. undead.

3 Wraiths: AC 3; MV 12"/24"; HD 5+3; hp 28,16,15; #AT 1; D 1d6 and drain one level; only be hit by silver (1/2 damage) or magical (full damage) weapons; AL LE.

23. Priesthood Cells

At either end of this 40-foot-long corridor there is a wooden door, and in the center lie 2 small vials. Ancient, rotting black drapes hide the entrances to four rooms on each side.

Each 10-foot-square cell contains dust and a broken cot. The vials have labels on them that read *Wight*. They are *potions of undead control* against wights.

24. Prayer Temple of the Priesthood

Old worn prayer rugs, their patterns faded and the cloth moth-eaten, are neatly placed about this 30-foot-wide room. A corridor enters the center of the north wall. In the center of the south wall, a 30-foot-tall statue of Amun-Re brushes its head against the ceiling, a giant gemstone glimmering in its forehead. A compass rose is carved into the floor in front of the statue.

There are secret doors at the north ends of the east and west walls.

Just in front of the statue, there is a trap door that opens suddenly into a 10-foot-diameter shaft falling 30 feet straight down. The shaft opens into a room with an additional 10-foot-drop into a haystack on the floor. Falling characters take 1d10 damage points from the fall and find themselves in the Minotaur Lair (Kor-dan's Master Maze Level area 25).

If the gemstone is taken from its place, the statue will make a horrendous noise, booming like a fog horn until the gem is put back. If the statue receives 50 damage points, the noise will stop. Roll for random encounters every round that the statue makes noise. The gemstone is glass and only worth 1 cp.

25-30. Observation Domes

These domed areas are the upper halves of the trap rooms on the Maze Level. The priests would stand on the ledges that encircle the base of the dome and look down on the trap below, watching robbers meet their doom.

If the PCs enter the dome by climbing up to the 3-foot-wide ledge that encircles it, describe the dome as follows.

The upper part of this room is a 30-foot diameter dome set atop a 10-foot-high wall. A 3-foot-wide ledge encircles the dome, overlooking the square room below.

Each dome connects to the rest of the Priesthood Halls Level through a concealed door in the wall beneath the dome. The doors open onto dark, dusty corridors. On the corridor floor before the entrance to each dome, a compass rose is carved, clearly giving the direction of north. From inside the corridor, the door is plain to see.

When the PCs enter one of these domes from the Priesthood Halls Level, describe the room they see below. Dome 25 opens over Javelin (Maze Level area 29). Dome 26 opens over X-Room (Maze Level area 30). Dome 27 opens over Pendulum (Maze Level area 31). Dome 28 opens over Pole Forest (Maze Level area 35). Dome 29 opens over Extra Trap Room (Maze Level area 36). Dome 30 opens over Loose Ceiling (Maze Level area 37).

Gauntlet Level Encounter Areas

For play in this area, refer to Map 8-5 in the *Map Booklet* and the appropriate inscription on the reverse of the DM's map.

The water column and rapids in this section contain Waters of Athis, which will heal 1d10 damage points once in 24 hours on anyone who drinks them.

Gauntlet Level Random Encounters

Munafik would not allow anyone to wander this level without being challenged, and so only his former priests, now undead will be encountered here. Check for random encounters once every three game turns. A roll of 1 on 1d6 indicates the possibility of an encounter. Roll 1d6 again and consult the corresponding encounter number from the following table.

Gauntlet Random Encounter Table

- 1-3. No physical encounter. Moans and shuffling in the distance may be heard.
4. 1d6 Ghouls: AC 6; MV 9"; HD 2; #AT 3; D 1-3/1-3/1d6; AL CE; hit causes paralysis.
5. 1-3 Wights: AC 5; MV 12"; HD 4+3; #AT 1; D 1d4 and level drain; AL LE.
6. 1-2 Wraiths: AC 4; MV 12"/24"; HD 5+3; #AT 1; D 1d6 and drain one level; AL LE.

1. Dome of Flight, Upper Level

This room is the upper half of the Dome of Flight (Priesthood Halls Level area 5). Read the first boxed description only if the party climbs to the ledge that encompasses the room.

The ledge, 3 to 5 feet wide, encircles the base of the dome. Its inner edge is octagonal and overlooks the palm trees and pool below. Its outer edge follows the curve of the 30-foot-diameter dome, which sits atop 20-foot-high walls. The tops of the palm trees are easily reached from this walkway, their pineapples easily picked.

Hanging from the lip on the south octagonal wall, just below the ledge, is the head of a carved lion, water gushing from its mouth. In the dome wall above this carving, there is a door.

The sound of rushing water is muffled here, and faint, but steady rapping can be heard from behind a large cut stone in the wall on the east side of the dome. The stone is 4 feet square by 2 feet thick. The rapping is in series of threes.

The ledge may be accessed most easily by using

the commands that alter its gravitational pull, but it may also be accessed by other more acrobatic means.

Behind the cut stone is Prit, a gnome who has been tunneling through the tomb for years, using only a spoon. Characters who tap on the stone will always be answered with like taps from the other side.

The stone is easily pulled aside to reveal the squirrely little gnome with a spoon in his hand. Speaking with a lisp, he will relate that he has been tunneling here for many years. He will tell that behind him, down the rough-hewn corridor (which he made), is a small statue with a big treasure. He is rather simple-minded and knows little more than the unsung history of spoons in architecture.

Prit: AC 9; MV 8"; HD 1; hp 4; #AT 1; D 1-2 (with the spoon); AL CN.

2. Entry Corridor

A 20-foot-long corridor runs south from a door and up at a moderate angle. There is the corridor splits into two 20-foot-long corridors 10 feet apart. Both of these corridors end in heavy wooden plank doors with bronze bands. There is writing carved in glowing gold letters into each of the doors; the golden runes are written in the ancient alphabet of the area.

Both doors carry the same runes, which are reproduced as Inscription 8Z on the reverse of the DM's fold-up map; it is translated as:

Beyond these doors lie the tests of the Pharaoh. Turn now from this doom of power and evil from a heartless man. Great and awful is the horror beyond these doors. Yet, if you turn away, what lies beyond ye shall never know.

3. Grand Hall of the Pharaohs (Gauntlet of the True Way)

This torch-lit sloping hall is vast and majestic, 100 feet long, 30 feet tall and 30 feet wide. It rises at a moderate angle toward the south, four flights of stairs connecting four landings. It appears that the landings are wider than the hall, but it is impossible to tell how much wider from the room's foot. On the top landing, which appears to be deeper than the others, a gigantic bronze fist rises atop a bronze forearm, doubtless some form of statuary.

Water thunders in torrents past both sides of the stairs and under the landings. Its roar masks any speech except a yell.

This was to be the last stronghold protecting the Pharaoh's tomb. When the pyramid was constructed, the only entrance to the True Tomb Level was through this hall, but ground disturbances and a spoon have made another entrance.

On each of the landings there are things that the party must overcome. The "test" on any particular landing will be concealed from the party until they get close. These tests form the Gauntlet of the Pharaoh. They are magical in nature, kept functional through the will and powers of Munafik, the former High Priest of Amun-Re who has now turned to evil sorcery.

Concealed on the top platform next to the giant fist is Munafik himself. He is now very powerful in his own right, and he will be a formidable opponent for the party. He will not show himself intentionally, but a very observant party member might spot his robes as he peeks at them when they enter. He will cast *comprehend languages* so that he can understand what the party is shouting. If any spells or missiles are directed toward this area, he may become affected and join combat from a distance. See the text for the Pet Fist (area 3d) for a description of Munafik's powers and abilities.

3a. Chabang Man

The 10-foot-wide stairs run up to a landing 10 feet deep and 30 feet wide. There appears to be an alcove at each end of the landing.

As soon as any member of the party steps onto the stairway, a human, looking thin and drawn, appears from each alcove, holding a sword. These monsters are magical creations that multiply if hit by a sword. When any cutting blow hits them, it will cut clean through. The severed part and the original body will dissolve into piles of mud. One round later a new monster will suddenly spring up from the piles, each exactly like the original. If struck by a crushing weapon such as a mace or hammer, the monster will collapse in *one* pile of mud, arising renewed one round later. The monsters can be stuck to the walls with spears, sword thrusts, or other stabbing weapons.

The alcoves are 10 feet deep. Within each are 50 spears.

2 Chabang Men: AC 10; MV 12"; HD 5; hp N/A; #AT 1; D 1d8; AL N.

3b. Fire Wall

The 10-foot-wide stairs run up to a landing 10 feet deep and 30 feet wide. There appears to be an alcove at each end of the landing.

The stairs are safe, this time, but when the first PC places a foot on the step just below the second landing, a roaring wall of fire suddenly will descend from the ceiling immediately in front of him, barring passage. Its heat can be felt on the face and skin, but it is an illusion. Because of this, neither cold nor water will lessen this flame, nor will wood burn in it. The searing heat will do 1d10 damage points to anyone who believes the flame is real and attempts to cross it. Save vs. spells will be normal if the character is unsuspecting, or at +4 if the character has verbally raised any doubts.

After passing through the illusionary fire, the PCs will be confronted with the following:

The landing is 10 feet deep and 50 feet wide, two 10-foot-alcoves on either side. A wall of solid stone runs from one side of the hall to the other. It rises to the full height to the ceiling, and blocks passage up the stairs or over the rapids. Only the rushing water below the landing is not blocked by this wall.

This wall is also an illusion with the same modifiers to disbelieve as noted above. Those who run into the wall believing that it is there will take 1d6 damage points and will fall down before the wall. Unless it is successfully disbelieved, the wall seems solid and real.

3c. Mirror, Mirror

The 10-foot-wide stairs run up to a landing 10 feet deep and 30 feet wide. There appears to be an alcove at each end of the landing.

As each party member steps onto the access stairway, an exact likeness of that character will appear on the landing at the top of the stairs. This monster will be armed as the character is armed except that magical weapons, magical armor, and other magical items will be replaced with non-magical items of the same kind and appearance. All of the characters' magical items will work as usual.

The monsters will immediately attack, on the stairs or on a lower platform if necessary. They are simple mindless creatures that will continue to fight until either the party or they are dead. Each monster only has as many hit points as the character it replicates has now; unless the character is undamaged, the likeness will *not* have that character's normal number of hit points. When killed, the likeness will change to a featureless clay humanoid form and will not move again.

3d. Pet Fist

The final flight of steps leads up past the rapid waters to a semi-circular area 30 feet wide by 20 feet deep. There is a bronze arm with its hand formed into a fist in the center of the area. Behind this can be seen a throne.

If the party has not yet met Munafik, he will be seated in the throne, waiting nearly motionless until the pet fist is bested before using any of his personal powers. Unless a party member specifically attacks him or comes too close, Munafik will remain placid and motionless until the pet fist can fight no more.

The pet fist will attack anything that moves within its 15-foot reach. When it has taken its full 50 damage points, it will collapse as a huge heap of mud. Then, Munafik will rise immediately, eyes blazing and face contorted in a hideous snarl. Levelling one hand at the party, he will cast a spell. He will behave *intelligently* in his attempt to best the party. If necessary, he will escape to another part of this level to continue the arcane combat there. Because he has hidden his heart elsewhere, Munafik cannot be damaged or killed by spells or blows. Cutting hits will slice right through him with no effect and thrusts will impale him but do no damage for his "heart isn't in it" (see area 8); he has trapped his soul elsewhere. Spells will affect him as they would any 10th level MU, except that damaging attacks have no effect. For example, a *hold person* will hold him, but a *magic missile* will cause no damage.

Pet Fist: AC 7; MV 3"; HD 10; hp 50; #AT 2; D 1d10/1d10; AL C.

Munafik: AC 7; MV 12"; MU 10; hp N/A; #AT 1; D 1d6; AL LE.

3e. Exit at Last

Behind the throne there is a set of bronze double doors.

These doors lead to the Pillar of Athis (area 4). They open easily and quietly.

4. Pillar of Athis

In the center of this 30-foot-wide semi-circular room, a 10-foot-diameter column of water thunders down from a circular opening in the ceiling, passing through a matching opening in the floor. The room shakes with the violence of the water flow.

There are 10-foot-wide corridors leading to the east and west. The common speech symbol for "7" is engraved in the floor in front of the opening in the floor.

Anyone verbally asking a question will trigger

a deep, watery voice that will speak from the pillar and ask three questions. If any of the questions is answered with a lie, the character answering will be struck by lightning for 1d8 damage points and the pillar will begin again with the first question. If a question is answered truthfully, the column will proceed to the next question until all three are answered. The questions it will ask are 1) "What is your name?"; 2) "What is your quest?"; and 3) "On whose hallowed ground stand ye?"

If the answer "Amun-Re" is given to the third question, the column will instruct: "Put thy hand in mine" and a white impression of a hand will appear in the floor in front of the column. Anyone of good or neutral alignment who places his hand into this will cause the water pillar to run backwards, from the floor to the ceiling. If an evil person tries to put his hand into the impression, a lightning bolt will gently knock him to the floor for 1-8 damage points. When the column is flowing backwards, anyone (regardless of alignment) stepping into the water during the next five minutes will be swept upward 30 feet to the Pharaoh's True Way (True Tomb Level area 1), with no danger of drowning.

5. Reading Room

An octagonal white marble room 30 feet across has 10-foot-wide archways in the east and west walls. An old book lies on a marble slab in the center of the room.

The book is a *Libram of Ineffable Damnation*. Any evil MU who reads this book will advance to the mid-point of the next highest experience level. The book takes one week to read. Any good or neutral person who reads even one word of the book will drop to the mid-point of the next lowest level of experience.

6. Waterbed

In the center of this 30-foot-wide octagonal room fashioned of white marble there is a 10-foot-wide by 15-foot-long pool of water. A large bed with satin sheets rides in the middle of the pool on pontoons, tied to the pool's edges with ropes.

7. Sitting Room

The floor of this 30-foot-wide octagonal room is covered with a rug, a nice contrast to the white marble walls and ceiling. A chair and a bench stand against the west wall.

8. Dining Room

This octagonal room 30 feet across appears empty. Archways in the east and west walls lead out of the room.

9. Storage Room

The north wall of this octagonal room has been broken through, with rubble and dirt piled on the floor. There is a 4-foot-wide by 5-foot-tall rough-hewn tunnel that appears to twist its way down and to the north. A 10-foot-wide archway is set in the center of the south wall.

10. Rumpus Room

The north wall of this octagonal room displays chains and open manacles, the pins missing.

11. Heart's Lair

At the end of the narrow, low-ceilinged, twisting tunnel lies a rough cavern, made more by force than grace from the fitted stones of the pyramid. Jumbled blocks are strewn about the floor. The cavern measures roughly 30 feet north to south and 40 feet east to west. Something can be seen glittering in a small cave in the northeast corner. A huge dark shape stands in front of the cave in stony silence.

A clay golem is guarding the Treasure and must be overcome. It will only attack if the characters approach within 5 feet of it.

Behind the golem in the cove is a glass bell jar that glints through the dust and soot that covers it. The jar is sealed to the base and the glass will break before the base will loosen. Within the jar (treat the glass as AC4; hp 28) a beating human heart can be seen. After the jar is broken; the heart will die. The heart is Munafik's; only the death of the heart will kill the evil priest of the pyramid.

Clay Golem: AC 7; MV 7"; HD 11; hp 50; #AT 1; D 3d10; AL CE/N.

True Tomb Level Encounter Areas

For play in the True Tomb Level, refer to Map 8-6 in the *Map Booklet*. There are no random encounters on this level.

1. The Pharaoh's True Way

The water flows up the shaft and splashes around approximately 3 feet above the level of a corridor. The corridor is 30 feet long, ending in a set of bronze double doors.

The water in the column is Waters of Athis, which give 1d10 points of healing to persons who did not drink of them within the past 24 hours.

The PCs can splash their way to the stone floor of the corridor without difficulty. After five minutes, the water flow will change direction, running down the shaft again instead of up. The water enters the shaft from a hole just below the floor of the corridor. Unless they have taken great care, light may be a problem because of wet torches.

The column cannot be entered safely from this room. Any who do so will make the following tumultuous journey. As the water plunges downward, the PC will fall with it, taking 1d6 damage points immediately. He will be carried through a duct and spilled out into the rapids of The Grand Hall of the Pharaohs (Gauntlet Level area 3); this passage, until he enters a duct at the rapids' foot, will give another 1d6 damage points. Eventually, he will be spewed out from the lion's mouth in the Dome of Flight (Priesthood Halls Level area 5). He will take an additional 1d6 damage points from the 30-foot fall to the pool below, from which adventuring may begin again. Should the PC die in the process, his body can eventually be found floating in this same pool.

2. Treasury of the Pharaohs

Bronze double doors open in the center of the south wall of a 30-foot-square room opposite another pair in the center of the north wall. Four pillars rise up to the ceiling. In the center of the room is a stand with a plaque on it which reads plainly, "Let him who knows our god speak his name."

On the west side of the room, occupying the full length of the wall, is a reed boat. Its mast is lashed to the floor alongside ten ornate, vase-like jars. There is a post in the boat's bow with what appears to be an empty setting for a huge gem on it.

On the east wall, there is a large painting of the same boat as on the west side of the room. In the painting, which appears to be

very well painted and highly detailed, the boat sails high above the clouds, carrying a large and beautiful gemstone in its bow.

The plaque is meaningless. Each of the ornate jars inside the reed boat contains 500 pp. The painting is the real key to this room.

The painting is really a window that looks out onto the air 10,000 feet above the pyramid. Anyone who tries to touch the painting will find his hand passing right into it. If a character sticks his head through it, he will find himself looking out over the clouds, as if from a window that is 10,000 feet in the air. Thirty feet beyond this window, an exact copy of the reed boat in the Treasure Room is anchored to a cloud, floating on air at the same height as the window. There is one important difference: the *Star of Mo-pelar*, needed to break the curse of Amun-Re and to gain access to the Tomb of Martek, is in the bow of this boat.

The characters will need to find some way of crossing the distance between the painting window and where the boat is anchored in the sky. Anyone who just steps through the magical window will fall 10,000 feet onto the pyramid, taking 20d6 damage points. No amount of effort will move the boat from its position in the sky. The characters might try to grapple the boat and cross on a rope, or they may use such spells as *fly* or *teleport*, which will operate through this painting/window.

The PCs are *meant* to steal the *Star of Mo-pelar*; failing to do so will leave Amun-Re's curse still operating. Without it, the PCs will not get into Martek's tomb. This relic is an opal ball, 5 inches in diameter. It behaves as a *Gem of True Seeing*.

3. Tomb of Amun-Re

Through the double doors and down a 10-foot long corridor, is the burial room, 30 feet wide by 40 feet long. The great sarcophagus is in the center of the room, a golden staff lying across it. Centered against the north wall, statue of Amun-Re stands; it holds a carved copy of the *Star of Mo-pelar* in its right hand and a carved golden staff, like that on the sarcophagus, across its body with its left hand. A phrase is written on both east and west walls in the ancient alphabet of this land.

Lying across the sarcophagus is Amun-Re's *Staff of Ruling*, the second of the two items required to break the Pharaoh's curse. It can be easily and safely taken from the top of the sarcophagus. It is a substantial treasure, worth 5000 gp, and the PCs are *meant* to steal it; failing to do so will leave the curse still in effect.

In the hands of one who knows how to use it, the staff is capable of three types of magic. The

staff holds 5 charges of each type. They are:

1. Striking the tip to the ground three times will cause the staff to polymorph itself into a large venomous snake with an alignment the same as the wielder of the staff. The snake will attack whoever the wielder directs. Grasping the snake firmly by the tail (-2 to hit) polymorphs the snake back to the golden staff. If the snake is ever killed in combat, it transforms into the staff at that spot.
Snake: AC 4; MV 15"; HD4; hp 28; #AT 1; D 1d4 + poison (save vs. poison or die).
2. Striking the ground twice and then spinning the tip in the air will create a globe of ball lightning. For every round the staff is spun before releasing the globe at its target, the lightning charge will develop 1d10 points of damage potential. The wielder cannot move, be hit, or be distracted while controlling the spin or the globe detonates on the spot with as much damage as had been spun to that point.
3. Striking the ground only once and then pointing the staff skyward will produce a clap of thunder of such volume that all exposed creatures within 1000 feet must save vs. petrification or be struck with fear for 1d10 rounds.

If the sarcophagus is opened, a mummy inside will attack.

Mummy: AC 3; MV 6"; HD 6 + 3; hp 40; #AT 1; D 1d12 + disease; AL C.

The inscriptions on the east and west walls are written in the ancient alphabet; they say the same thing. These inscription are reproduced as Inscription 8AA on the reverse of the DM's fold-up map; they translate as:

A passage was always provided between the Tomb of the King and his likeness, whereby his spirit may pass into his ordained statue and live within the stone we worship in the outer world.

The statue is a secret door that leads to a 10-foot-wide by 20-foot-deep alcove. If a character holds the *Star of Mo-pelar* in his right hand and the *Staff of Rulership* in the left (as the statue holds them), he and whoever is touching him will be able to teleport to the area behind the statue in the Meditation Room of the Temple (Temple area 10). Teleportation can be accomplished in both directions by a person holding these items this way. To reuse the teleport chamber in the opposite direction, the whole party must leave the alcove and then enter as described above.

Chapter 9: The Oasis of the White Palm

The Oasis is the linking point that will give the players information about where two more of the Star Gems may be found. It is important because it will provide additional impetus for the PCs to take steps against the efreet they released in Pazar.

Play here will be more role-play than dungeoning. There are a variety of interesting NPCs and two special encounters. Maps of the Oasis Area, the Nomad Camp, and the Sand-voyager Compound are provided for play. Use these from the *Map Booklet* and the appropriate inscriptions from the reverse of the DM's fold-up map.

Background

By the time the PCs arrive, the Oasis of the White Palm will be the only remaining stronghold left in the area that has held out against the Efreet Pasha Khalitharius and his evil minions. The Oasis, nevertheless, is no calm and safe refuge, for the people who dwell within its shade are split into three separate factions. Each faction has its own purpose and goals, not all of them contrary to those of Khalitharius. These factions are the sheik's loyalists, the Raurindi Dervish cultists, and the slave traders; each is described below.

The Sheik and His Loyalists

Sheik Kassim Arslan controls the Oasis. Nominally, all the Oasis residents fall under his power. He is a fair, but stubborn man, and has ruled the Oasis for more than 20 years. He has twin sons, Hassan Arslan and Korus Elkoth, born of the first of his wives. He has a cadre of Durpari and converted Raurindi who are intensely loyal to him and his successors. The Airlancers of the White Palm are the most elite warriors among these.

In the fashion of the peoples of this area, Sheik Kassim's rule will pass to his first-born son Hassan, who has been betrothed recently, though his bride-to-be has since disappeared. The younger twin, Korus, is intensely jealous of his older (by mere minutes, a stroke of ill luck) brother's position of power, and he has long harbored hatred for both the sheik and his heir, though he has been able to hide this successfully from his father.

Though some of his advisers believe the sheik to be the target of assassination, the sheik himself is not convinced. What he cannot see is that Korus' hate and lust for power has allowed him to be used by the Dervish cultists, who would assassinate the sheik and place Korus on the throne.

The sheik and his Loyalists are aware, however, that the Dervish cultists exist. The sheik feels unwilling to act against them because they have as yet done nothing to threaten him, his succession, or his tribe. Not exactly secretly, but then not with his blessing, the Oasis

Airlancers and others among the Loyalists track down suspected Dervish cultists, and quietly deal with them. As yet, no Loyalist has discovered the cultists' secret meeting place.

The Dervish Cultists

Many years ago, most of the Raurindi converted from their dervish-like ways and began worshipping Anu, the only god worshipped by the Durpari who had absorbed them. Some Raurindi, though, never gave up their dervish faith and the old ways. Sought out for holy retribution by the Durpari, whose monotheistic religion was intolerant of such things, anyone continuing to worship the older gods of the Raurindi was converted or killed — sometimes both. Presently, particularly in the deserts of Raurin, those who cling to the old ways have concealed their true beliefs and live the lives of Anu-worshippers. These people have formed a secret religious cells based on the old worship of many gods. These are the dervish cultists.

The dervish cultists in the Oasis, led by Corga Kazan who masquerades as a water bearer, secretly plot to overthrow the sheik, take control of the Oasis, and return to the old ways of worship. They would like to assassinate the Sheik's first born son and place his second son, a secret cult member, on the throne. As yet, the cultists have not been clever enough to avoid the sheik's guards and kill him.

The Slave Traders

For centuries, the Oasis has been a stopping point and reprovisioning area for the Sand-voyager Guild caravans that cross the desert. Recently, however, the local guildmaster was abducted and imprisoned by the slave traders who use the Guild to mask their activities. Thumas Netmaster, their leader, has taken his place. They have been under constant threat of discovery by the sheik. Since their discovery that Corga Kazan is the cult leader, they have tried to ally themselves with the cultists. It is the slave traders who stripped the bodies on the Battle Plain (Desert area 13).

The Situation

When the PCs arrive at the Oasis, things there are explosive. Until very recently, the three factions maintained a careful balance. Each watched the others, waiting for a false move.

Days ago, however, Khalitharius materialized within the inner sanctum of the cult's temple while their priest Corga was there. Corga, realizing how powerful the efreet was, pretended to worship him. The efreet told Corga that he was searching for a certain woman of the desert with a design on the palm of her hand.

Though Corga knew that this was none other than the betrothed of the sheik's first-born son, he did not admit this. He thought he would capture the princess himself and trade

her for the efreet's help in seizing personal control of the Oasis. So Corga lied and promised to try to find her for him.

Corga devised a plan to have the slavers kidnap the princess. Then, he would use her to bargain with Khalitharius for his aid, intending to destroy the sheik and both sons. That would leave only Corga to rule the Oasis.

The slavers agreed to Corga's plan, but on the night of the planned kidnapping, Princess Shadalah disappeared. Unknown to the humans plotting their treachery, Khalitharius found the princess himself and took her to the Crypt of Badr Al-Mosak, where his minions have their stronghold.

Now the Oasis is nearly explosive with tension. The sheik, his elder son Hassan, and the Loyalists want desperately to find the bride. They have sent out small search parties (larger ones would expose the sheik to assassination), but have met with no success. The dervish cultists believe that the slavers have the bride and are holding out for a bigger share of the spoils. The slavers, who find themselves under increasing suspicion from the Loyalists, believe the cultists have taken the princess without their aid and wonder why the arrangement was changed. All the factions want the bride's return. None of them know where she is, though everyone in the Oasis knows the location of the Crypt.

It is into this tense situation that the party of adventurers arrives.

The Palm Sign and Amulet

The palm sign is a symbol that magically appears on the palm of the woman chosen by fate to be the bride of the sheik of the Oasis. The mark also appears on the palm of the woman betrothed to the sheik's first-born son. The sheik and his son each wear an amulet that matches the palm sign. The origins of the amulet and the palm mark were lost in antiquity, and no one now knows their true purpose.

Martek, after his visions of the future, gave the palm sign and the amulet to the leader of the Durpari who lived in the area of the White Palm. They were to be carried down through the ages until the time when the two would be combined to tell where and how to release the djinn vizier Aeraldoth awaiting at the Lost City of Phoenix.

The message can be read only when the amulet and the palm mark are aligned together. The message reads:

City of Phoenix over the house of Set
where sleeps salvation

There speak atmophryeetno.

Atmophryeetno is the word that will release Aeraldoth.

No one at the Oasis knows that the amulet is also a weapon created by Martek to help mortals contain the efreet until Aeraldoth can be released. It glows in the presence of Khalitharius and has the power to give him great pain, just as Martek once did at the area now known as Skysea. It will drive him away and protect its wearer from the efreet's fire damage.

Major Non-Player Characters

Because it is likely that the PCs will meet several of the major NPCs outside of their bedchamber, and because role-play is the only way that the place can proceed in the Oasis, the major NPCs are grouped here.

This section presents the important information about the major NPCs that could be encountered in the Oasis, the Nomad Camp, and the Sandvoyagers Compound. They are grouped into four divisions: the sheik and his loyalists, the dervish cultists, the slave traders, and the information sources.

The Sheik and His Loyal Followers



Sheik Kassim Arslan: AC -1; MV 12"; hp 82; F 9; #AT 3/2; D 1d8 + 7; AL LN; S 18/90%; I 14; W 11; Dex 16; Con 17; Ch 16.

He uses a *scimitar* +3 and *shield* +1, and wears *chain mail* +3. He also wears a *scarab of protection* and carries a *potion of invulnerability* within the folds of his flowing robes. Around his neck is an amulet identical to that worn by his first-born son, Hassan.

The amulets that he and his first-born son wear have been handed down through the centuries. Their markings have strange and mystic meaning which, he believes, is some sort of story. The amulets are the badge of his office as well as a link between the sheik and his first wife.

The sheik is in a dangerous position at this time. The younger of his twin sons, Korus, hates him and seeks to kill him and his elder son. The line of royal authority passes from

father to first-born son. Should the first-born die then the second son will take his place. Through this custom, Korus hopes to gain the sheik's office. Although others suspect there is a plot to assassinate both the sheik and his first-born son, the sheik is not convinced this is true. No one close to the sheik suspects that Korus is instrumental in that plot.

The sheik is not fond of outsiders, and those who do not bring expensive gifts should not expect to be granted an audience. In fact, those not bringing expensive gifts of 1,000+ gp value or a magical weapon will not be admitted unless they have a medallion or some other sign from a person the sheik knows and trusts. The sheik never speaks directly to anyone other than his true friends, whom he always honors. For such friends he holds a feast and gives them a medallion that identifies them as allies of the Durpari.

In addition to the above, the sheik knows:

In the Durpari altar to their one god, Anu, is an ancient circular symbol. When the first-born son of a sheik comes of age, the symbol disappears from the altar and reappears on the palm of the hand of the Durpari girl destined to be the son's first wife. The symbol remains on the girl's hand until her death, when it reappears on the altar, or until her own first-born son comes of age and the symbol is passed along to his intended bride.

Not only has Princess Shadalah, the bride of Hassan, disappeared, but others have disappeared from the camp on those occasions and it is feared that a terrible demon has kidnapped the people.



Sothal, sheik's favorite slave girl: AC 10; MV 12"; F 1; hp 6; #AT 1; D 1-2; AL N.

Sothal is very perceptive, bright, and fiercely loyal to the sheik. She has become the sheik's favorite, someone he talks to while he sorts things out in his mind. She will be one of the two slave girls present if the PCs have an audi-

ence with the sheik (see the section on Special Encounters in *Expected Play*). At any other time the PCs encounter one of the Sheik's slaves, a roll of 1 on 1d4 indicates that she is one of them.

She is aware of the trouble at court but, because she is a slave, is powerless to do anything about it openly. If the PCs convince her then that they are honorable people who can help her, she will spill her pent-up feelings to them, begging for their help. She believes but cannot prove that:

There is a plot afoot to assassinate the sheik and Hassan, but the sheik is too stubborn to see the danger.

Certain members of the sheik's own guard are traitors. Their plan is to kill the sheik when he goes in search of Princess Shadalah. He must not leave the encampment.

The former manager of the old Sandvoyagers warehouse, Tolnus Granicus, who has not been seen for some time, is a victim of foul play.

Someone in court is a party to the assassination plot. Many in the tribe have secretly returned to the worship of idols.



Hassan Arslan, sheik's first-born son and heir: AC 0; MV 12"; hp 53; F 7; #AT 3/2; D 1-8 + 3; AL LN; strength bonus +2 to hit; +3 damage; S 18/56; I 11; W 12; Dex 17; Con 14; Ch 2.

Hassan is usually armed with a *scimitar* +2, a *dagger* +2, and *chain mail* +2.

Hassan is the identical twin of Korus Eikoth, although Hassan was born first and therefore is the sheik's heir. He has compassion for his brother's feelings of anger and jealousy because of this, but he knows that nothing can be done to alter Korus' hatred.

Hassan was recently betrothed to the Princess Shadalah, who was almost immediately kidnapped by the wicked efreet Khalitharius. Hassan is holding up under the loss of his bride-to-be but occasionally lapses into sadness. He will do anything to regain her and accept any honest offer of assistance, even if

that assistance is at a price. Hassan has an amulet identical to the sheik's, which is a badge of his office; it is a link to the mark on his betrothed's hand, as described in the section on *Background*. He will give to the party if they agree to recover his beloved. He knows the following information:

He has just been betrothed to Princess Shadalah and the feast of celebration had begun, when she suddenly disappeared.

Korus has been acting very strangely of late. He is never in attendance at the offering on the holy days and stays by himself.



Nadron Ilanis, Cleric of Anu: AC 4; MV 12"; hp 29; C 6; #AT 1; D 1d6 + 2; AL LN; S 11; I 10; W 16; Dex 14; Con 13; Ch 17.

He wears a *cloak of protection +1* and carries a *staff of curing* with 12 charges. Within the folds of his robes, his *flail +1* swings from his belt. Three scrolls are pocketed: *neutralize poison*, *raise dead*, *blade barrier*. All three scrolls are written at the 11th level of spell use. His spells include *command*, *cure light wounds (x2)*, *sanctuary*, *protection from evil*, *hold person*, *slow poison*, *speak with animals*, *know alignment*, *detect charm*, *cure disease*.

Nadron and the other clerics of Anu are loyal to the sheik. Nadron seldom speaks with outsiders and has a fanatical hatred of dervish worship. He possesses the following knowledge:

The symbol on the palm of Hassan's bride comes from a tradition that is almost as old as the tribe itself. Only one woman at a time may bear the symbol and only so long as she lives, or until it passes on to the new bride.

The old beliefs say that the first bride has great power over evil because of the mark on her hand. Nadron thinks this is superstition and that the mark is important only for the sake of tradition.

The symbol has not yet returned to the altar; therefore, the bride must be alive.

The truth about the White Palm tree near the Oasis Pool is that if one plants a

date from the tree while praying to Anu, the date will grow into a full-sized tree in only one week. Nadron also knows that if the white tree is harmed, Anu will be angry.

The sheik believes that the Oasis of the White Palm was once the ancestral home of the tribe because of the writings found inside the old temple in the compound. The writings say "The place is set, but no man knows the time." Nadron finds it disgusting that the sheik should believe the sayings of idol worshippers.

The Dervish Cultists



Koru Eikoth, second son of the sheik: AC 1; MV 12"; F 7; hp 45; #;AT 3/2; D 1d8 + 4; AL LE; strength bonus +2 to hit, +4 damage; S 18/88; I 11; W 9; Dex 15; Con 15; Ch 10.

Koru is armed with a *scimitar +1* and wears *chainmail +2*. He also has one *potion of ESP* and six *arrows +1*.

Because he was born only minutes after his twin brother Hassan and so narrowly missed being his father's heir, Koru has always harbored a deep hatred for his father and his brother. Koru is basically dishonest and cannot be counted on to keep his word. He will tell any lie that will further his plans. He is a member of the dervish cult, which operates secretly at the Oasis.

Koru is now trying to find his brother's bride-to-be — but not out of goodness. He knows that the girl is the key to power in the Oasis. Koru will try to enlist the aid of the players in finding the princess, as described in the Special Encounters section of *Expected Play*.

From dawn to midnight he can be found in his tent, lounging and eating while his slave girl dances for him. Just before midnight, he goes out, after making sure that the guards do not see him. He chose his tent location because of this nightly visit to the Temple of Set, through the door in the Monolith (Oasis area 7). He can be seen crossing over the cloth bands and entering the undergrowth in the Oasis every night, just before midnight.

Korus knows the following information:

The leader of the dervish cult wishes to turn Princess Shadalah over to a very powerful spiritual ally.

The Sandvoyagers Guild has been taken over by outsiders. Very little trade has come into the warehouse but quite a bit has been going out.



Corga Kazan, dervish cleric: AC 5; MV 12"; C 5; hp 27; #AT 1; D 1d6 + 2; AL LE; S 14; I 12; W 15; Dex 13; Con 14; Ch 10. He carries the following spells: *command*, *cure light wounds*, *darkness*, *light*, *sanctuary*, *hold person* twice per day, *silence 15' radius*, *know alignment*, *dispel magic*.

He is armed with a *mace +1* or, if found in his sanctuary, the *skull of Garath*. Corga masquerades as a water bearer because Thune worship is officially forbidden.

Corga is of the opinion that the PCs are actually working for the slavers. Corga thought he had a deal with Thurnas Netmaster, head of the slavers, but now he believes Thurnas obviously has betrayed him. He will treat the party as slaver spies. Corga believes the following:

The bride of Hassan must have some special power over the efreet Khalitharius. The efreet appeared to him in flame and smoke and promised Corga all that he deserved if he would deliver the bride of Hassan unto him. Knowing that the Evil One would not want such a prize without purpose and, since Corga both feared and respected the power of the Evil One, he agreed to find the princess.

He made an arrangement with the slavers and Zoarth Blackblade to kidnap the princess. In exchange, when he came into power, Corga would allow the slavers to operate freely. However, the slavers failed to deliver the girl. Corga is sure that they have her and that they are holding her for a bigger ransom.

Corga believes he can discover the secret of the girl's power over the Evil One and use that power to seize control of the Oasis.

The Slave Traders



Thurnas Netmaster, slaver head: AC -1; MV 12"; F 7; hp 59; #AT 3/2; D 1d8 + 2; AL NE; S 18/22; I 14; W 10; Dex 12; Con 16; Ch 14.

Thurnas possesses a *shield* +2 and *plate* +1 although he rarely uses them. He is armed with a *longsword* +2.

Thurnas is the leader of the slavers and is working with Drow allies. He believes that the player characters are not only wanderers who have happened upon the oasis. Normally he would attempt to kidnap party members for sale later, but as the religious fanatics in the compound are quite upset with him currently, he and his band are lying low. His assassin, Zorath Blackblade, was assigned to capture the bride but found that she was already missing. Thurnas is looking for the bride himself. He believes that the cultists have the girl hidden and are trying to back out on their agreement with him.



Zorath Blackblade (Slaver Assassin): AC 5; MV 12"; hp 19; A 5; #AT 1; D 1d6 + 1; AL NE; S 16; I 14; W 9; Dex 16; Con 11; Ch 9.

Zorath's thieving abilities are:

Pick Pockets	40%
Open Locks	38%
Find Traps	30%
Move Silently	27%
Hear Noise	15%
Climb Walls	87%

Zorath, who can be seen sitting in Happy Hogan's Desert Igloo every night, is under contract to the slavers and was recently assigned to abduct Princess Shadalah, the bride-to-be of Hassan. When he arrived at the camp, he found it already in turmoil over her disappearance. He thinks the cultists have her in their secret temple somewhere in the Oasis.

Information Sources



Happy Hogan Underwood, tavern owner (retired thief; halfling): AC 1; MV 9"; T 14; hp 56; #AT 1; D by weapon; AL N; S 13; I 16; W 14; Dex 18; Con 15; Ch 14.

He possesses the following magical items: *dagger* +1; *cloak of protection* +3; *short sword* +3 (named Shylo's Slicer; I 14; E 7; AL N; detects sloping passages, teleports 6,000 gp weight once per day; speaks Halfling), *ring of invisibility*, *ring of spell turning*. Each time a magical ring is used by a halfling, there is a 20% chance that the ring will fail to operate.

Hogan's thieving abilities are:

Pick Pockets	125%
Open Locks	107%
Find Traps	95%
Move Silently	119%
Hide in Shadows	118%
Hear Noise	45%
Climb Walls	84%
Read Languages	65%

Hogan is a kindly-looking, elderly halfling, and unknown to anyone, a retired master thief. Among his many aliases are: Hogan the Happy, Hogan the Huckster, Shylo Slick, Aldo Chella, Rory the Ransacker, Negel Broos, and Sedgewick Paddington the Third. Player character thieves have a 75% chance to recognize the name Shylo Slick as that of a famous halfling thief who disappeared some years ago.

Hogan is suspicious of strangers but is loyal for life to his friends. Hogan knows the following and will volunteer it only to someone he trusts:

Hassan, first born son of the sheik, knows how to pilot a sand sled.

The guildmaster of sandvoyagers has not been seen for many days although Hogan received parchments with the guildmaster's signature two days ago, requesting good wine and ale.

Corga the Water Bearer is never seen before noon at his little place in the courtyard.



Rose Underwood, halfling waitress: AC 7; MV 9"; F 1; hp 5; #AT 1; D 1-4; AL N.

Rose is Hogan's niece, here visiting her uncle for a while. She waits tables in Happy Hogan's Desert Igloo every evening from dinner until closing. She is shy of strangers but will talk once she warms to the conversation. She knows the following useful information:

She has been awakened in the middle of the night by strange noises coming from somewhere just north of the compound.

She was once walking behind the smithy and saw one of the sheik's sons enter the Sandvoyagers' Guild by a secret way. She doesn't know which one as they are identical twins and she cannot tell them apart.

Her uncle is a pillar of the community and very honest.



Roland the Minstrel: AC 6; MV 12"; F 1; hp 8; #AT 1; D 1d8+1; AL NG; S 16; I 12; W 15; Dex 16; Con 11; Ch 17.

Roland is normally secretive and does not answer questions, but at the same time tries to give the impression that he knows a great deal of important information. In fact he knows only:

The ruins under the Oasis as well as those at Phoenix were constructed long ago by the Archmage Martek. At each of those locations a temple to Set was built after Martek concluded his work. This did not stop Martek from using them after the destruction of the cities for the purposes that he foresaw.

Martek was the greatest mage of his age and foresaw the course of future history. He left a great gift after his death to the Sultanate of the tribes. To them was given the knowledge of where the Great Good sleeps, to be loosed when the Evil came.

The ancient city of Phoenix was located west by northwest of where the Oasis of the White Palm stands.

Martek was perhaps the greatest mage that ever walked the desert wastes. His works of wonder in magic and architecture remain unsurpassed. It was he that delivered unto the Pharaohs of his day the five Star Gems: Mo-Pelar, Shah-Pelar, Khan-Pelar, Aga-Pelar, Melos-Pelar. These stones were unlike any others in the world and around them arose a great mystery. The Citadel of Martek was the mage's greatest creation.

He knows part of Martek's epic:
When the evil walks our land again,
Will nomadic princes come to set
His power into the first bride's hand,
That good and evil then are met.

Then will needs be,
Five Star Gems see,
To my tomb be borne hither
And hope shall not wither.
Open the gates to my Sphere of Power,
And put off evil in its appointed hour.

Special Encounters

There are two special encounters described here. The first is the audience with the sheik, which will occur if the PCs are brought to him by the Airlancers, if the PCs are accused of a crime in the Oasis, or if he grants the PCs an audience. The second is a special encounter with the Sheik's younger son. This will occur the first night that the PCs are in the Oasis, regardless of where they are staying.

Audience with the Sheik

Within the main chamber of the sheik's tent, two slave girls stand near the entrance. Opposite them, a man, richly garbed in fine silk robes and a jewel-laced turban, sits atop a pile of pillows; an ornate medallion hangs from his neck. A young man wearing long robes sits on pillows to the elder man's right; he wears an identical medallion. Two large and fierce-looking men stand on either side of him, their arms folded.

The man upon the pillows is the sheik, with his son Hassan sitting on the floor at his feet. His bodyguards stand behind as he watches the dancing slave girls. During this encounter, the sheik will never address the party directly until he feels that they are worthy; his son Hassan will rise and speak for him instead. The bodyguards will defend the others if any threat is made, and the slave girls will do the sheik's bidding, one of them coming to the attention of the PCs as she watches them closely.

2 Guards: AC4; MV 12"; F 4; hp 30, 25; #AT 1; D 1d8+2; AL LN. They carry scimitars and composite bows. Each has an *arrow* +1.

If the Airlancers have brought the party to the sheik, they will remain outside save for their leader, who will speak to the sheik, relaying all he has learned. If the medallion given the party by the dying man on the Battle Plain is brought into the conversation, things will proceed much more smoothly for the PCs. If the PCs have bribed their way into the sheik's presence by an expensive gift (1000+ gp value or magic), then the sheik will be neutral and attentive. It will be clear to the PCs that the burden of winning the sheik over will be on them.

If the sheik feels the PCs are worthy, in particular if they show him the warrior's medallion, he will then ask their aid, saying:

I am most happy to welcome you to our humble oasis home and wish you all health and happiness during your stay among us. May our saddened hearts not dim the glory of your lives.

Now I would seek your aid in a matter of great importance to me. Hear my tale and, if you be friends and willing, aid me as you may.

While many among my people enjoy great health and happiness, there are those who, I am told, wish harm to me and my sons. The discontented are always among us, but never have they dared to act before now.

Seven suns ago, Shadalah, a young noblewoman from our tribe, was betrothed to my first-born son, Hassan. She was the chosen bride because she had, upon the palm of her hand, the sacred symbol. After their betrothal the three-day feast began.

Yet, the place was set and no man knew the time. May Anu guide us! That very day, word came by runner saying that the army was needed to fight an evil efreit in the north. The warriors departed at once. On the following night, Princess Shadalah disappeared. The marks in the sand outside her tent told of a struggle. The trail ended just north of our camp.

Our warriors have struggled to hold the Evil One and his army at bay. They have kept us safe until now, but their absence has weakened my position here and made my enemies bold. I am advised that my enemies here in the camp, whoever they may be, may have Hassan's bride.

I ask you to help us recover Shadalah, the beloved betrothed of my first-born son. My second son, Korus Eikoth, will aid you if you wish. And if you find her, then the wealth of my tent and the friendship and service of my kingdom shall be yours.

If the party agrees to help the sheik find the princess, the sheik will ask Hassan to give them his medallion. He will present them with three *Scimitars of the Sultan* +1, +3 (vs. undead). In addition, he will communicate the other things he knows, as detailed in the section on *Major NPCs*.

If the party comes before the sheik because a character has been accused of theft, the sheik will try and judge that PC. A character found guilty will be punished by seven blows from a flail. The sheik is, however, greatly amused by stories and will allow each person found guilty one minute to tell him a tale. If the tale is more fantastic than any he has heard before, then he will pardon the group with a warning. Each offender must make a Charisma check at -5 to determine if the tale he tells is indeed more fantastic than any the sheik has heard. The DM can ask that each PC tell such a story about his adventures. If the tale is good and can be told in one minute, the DM can adjust the roll anywhere from -5 to no subtraction.

If the sheik doesn't like them, the player

characters will be imprisoned for the night and promised a flogging in the morning. However, Korus Eikoth will visit them that night as outlined under the second of the Special Encounters, as described below. The party will be freed the next morning by the sheik after a warning and a flogging with 1d8 points of damage.

Meeting with Korus

At some time during the first full night the PCs remain in the Oasis area, they will be sought out by Korus Eikoth, the sheik's second son, with a proposition. Posing as his brother, if he can get away with it, he will ask the party to find Princess Shadallah here in the Oasis, saying he believes that certain people in the Sandvoyagers Guild are holding the girl in their warehouse (Sandvoyagers Compound area 8).

Korus will offer to pay the party handsomely in addition to what the sheik has promised them. If they agree to help him, he will also give them three *maces* +1. He will provide any information about Shadallah that will help the party recognize her, but, beyond that, he will be very vague and secretive. He will warn them to bring the girl straight to him and not let anyone else see her, saying that he will wait for them after dark by the Monolith (Oasis area 7).

If the party accepts Korus' offer, then Korus will be found by the monolith every night about one hour after sunset and will remain until midnight. At midnight, he will go through the secret door in the monolith and enter the Temple of Set for worship service. Once he has the princess in his grasp, he secretly plans to kill the party.

After this encounter, if the party meets Korus, he will restate his offer or, if the bargain has been made, will ask how things are going.

Other Encounters

Durpari Lancer Encounters

Throughout the Oasis, the Nomad Camp, and the Sandvoyagers Compound, the Durpari Lancer patrol. At any time that trouble breaks out, 1d8 + 4 of them may be summoned with a yell, and they will arrive within 2d8 rounds. The guard will attempt to halt hostilities and bring all involved parties before the sheik for judgment. The guards do not believe they have the wisdom to deal out justice themselves and will insist on going to the sheik.

Durpari Lancer: AC 4; MV 12"; F 6; #AT 1; D 1d8 + 2; AL LN; strength bonus +1 to hit, +2 damage.

Oasis Area Random Encounters

Check for random encounters once every three turns. A roll of 1 on 1d6 indicates that an encounter takes place. If an encounter is indi-

cated, roll 1d6 and use the corresponding encounter number from the Oasis Random Encounter Table below that corresponds to the time of day.

Oasis Daytime Random Encounter Table

- 2d4 + 4 Women: AC 10; MV 12"; F 1; #AT 1; D Unarmed; AL LN. They will be carrying water.
- 1d4 + 2 Women: AC 10; MV 12"; F 1; #AT 1; D Unarmed; AL LN. They will be carrying laundry.
- Trader: AC 8; MV 12"; F 1; #AT 1; D 1d4; AL LN. He is carrying beads, rugs, bolts of cloth, statuary, or some other single item. If this encounter is rolled again, use a different commodity.
- 1d4 Traders: AC 10; MV 12"; F 2; #AT 1; D 1d4; AL LN. These traders will be bearing large baskets of dates.
- 1d4 Traders: AC 7; MV 12"; F 3; #AT 1; D 1d8 + 2; AL LN; strength bonus +1 to hit, +2 damage. These traders will be leading camels.
- 1d8 + 4 Durpari Lancers: (see above).
- 7-8. Re-roll on Oasis Special Random Encounter Table.

Oasis Night Random Encounter Table

- 1d4 Drunken Durpari: AC 4; MV 12"; F 4; #AT 1; D 1d8 + 2; AL LN; strength bonus +1 to hit, +2 to damage. Fights as first level due to drunkenness.
- 1d8 Slaver Guards: AC 4; MV 12"; F 2; #AT 1; D 1d8; AL NE.
- 1d4 Dervish Cultists: AC 6; MV 12"; F 4; #AT 1; D 1d8 + 2; AL LN; strength bonus +1 to hit, +2 to damage.
- 1d4 Male Drow: AC 1; MV 12"; F 4; #AT 1; D 1d6; AL CN; SA *dancing lights*, *faerie fire*, *darkness*; SD +2 to all saving throws; MR 56%.
- 1-2 Durpari Nobles: AC 4; MV 12"; F 5; #AT 1; D 1d8 + 2; AL LN.
- Durpari Slave: AC 10; MV 12"; F 1; #AT 1; D Unarmed; AL NG. He/she will be on an errand for his/her master.
- 7-8. Re-roll on the Oasis Special Random Encounter Table.

Oasis Special Random Encounter Table

For details about the encounters below, refer to the previous section on *Major Non-Player Characters*.

- Hogan Underwood, retired thief; halfling: AC 1; MV 9"; T 14; hp 56; #AT 1; D by weapon; AL N. He carries the following: *dagger* +1; *cloak of protection* +3; *ring of invisibility*, *ring of spell turning*.
- Zorath Blackblade, slaver assassin: AC 5; MV 12"; A 5; hp 19; #AT 1; D 1d6 + 1; AL NE.
- Rose Underwood, halfling waitress: AC 7; MV 9"; F 1; hp 5; #AT 1; D 1-4; AL N.
- Thurnas Netmaster, slaver head: AC -1; MV 12"; F 7; hp 59; #AT 3/2; D 1-8 + 2; AL NE; strength bonus +1 to hit, +3 damage. He is armed with a *longsword* +2.
- Hassan Arslan, sheik's first-born son and heir: AC 0; MV 12"; F 7; hp 53; #AT 3/2; D 1-8 + 3; AL LN; strength bonus +2 to hit, +3 damage.
- Roland the Minstrel: AC 6; MV 12"; F 1; hp 8; #AT 1; D 1-8; AL NG.
- 7-8. Corga Kazan, dervish cleric: AC 5; MV 12"; C 5; hp 27; #AT 1; D 1d6 + 2; AL LE. He carries the following spells: *command*, *cure light wounds*, *darkness*, *light*, *sanctuary*, *hold person twice per day*, *silence 15' radius*, *know alignment*, *dispel magic*. He is armed with a *mace* +1.

Oasis of the White Palm Encounter Areas

These encounter areas are keyed to Map 9-1 in the *Map Booklet*.

1. The Oasis

The oasis is nearly a mile across, with dense growth at the center scattered trees and shrubs at the edges. Tents are scattered in the sand beneath the trees at the outskirts, with a concentration of them to the north west.

Mounts, as they smell the water ahead, will pick up their pace. If the PCs are under guard, they will proceed directly to the Nomad Camp and the Sheik. If they are approaching undetected by the Airlancers, they need not do so.

2. The Nomad Camp

On the northwest side of the oasis, lying at its green border, sprawls a great nomad camp, nearly 1000 feet across and half that deep. Many small tents encircle one very large tent, there being perhaps 100 tents in all. Near to the ground, a one-foot wide band of green cloth encircles the camp some 50 feet from the outermost tents, stopping at the main entrance. A similar band of red cloth encircles the camp at a distance of 30 feet from the outermost tents.

Four men in desert robes guard the main entrance to the camp. Other robed guards patrol the camp perimeter on horseback.

For further play in this area, refer to the Encounter Area descriptions and the maps for *The Nomad Camp*.

3. The Oasis Pool

Beneath the shade of many luxuriant and tall palms, lies the oasis pool. Several hundred feet in length and width, it has an irregular shape. Its surface is calm and reflective, the water slightly brownish and crystal clear.

Eight guards with drawn swords stand guard around the pool at all times. Under orders from the sheik to protect it and to collect money for any water taken or used, they will demand payment before they will let strangers close to the pool. The cost is 1 gp for a flask or small jug of water, 2 gp for a large jug of water or watering a horse, 4 gp for watering a camel. At night, the area is well-lighted by torches.

Pool Guards: AC 6; MV 12"; F 1; #AT 1; D 1d8+1; AL LN.

4. The White Palm

A white palm, its bleached bark a stark contrast to that of its neighbors, stands amid several other trees. Dates in dark brown clusters are nearly concealed by its lush green leaves spreading overhead.

Any interference with the trees will seriously offend the Durpari. Destroying it will bring the wrath of the sheik, the dervish cultists, the slavers, the Sandvoyagers, the Airlancers, and all travelers through the desert. If the party messes with the palm, they are asking for big trouble.

If any date from this tree is planted near water, it will grow into a full-sized, normal date palm within one week. Because of it, the desert oases are never without shade.

5. Headless Statue

Amid a few palm trees is a headless statue of a regal figure seated on a throne. The statue is partially buried in the sand. The head of the statue lies on the ground 15 feet away.

The stone head weighs 500 lbs. It is of no value.

6. Burned Camp

Strewed about are the charred remains of an encampment. The sand is scorched, and the vegetation nearby has died back, though it is recovering. A sign warns outsiders of what happens to those who offend the sheik.

7. The Monolith

In the center of several screening palm trees, the 25-foot-tall by 7-foot-square monolith towers up from the sands. The writings on its surface in the old alphabet are nearly obscured by time and weather.

There is a secret door in the north side of the monolith. It leads to a stair that descends to an ancient tunnel running south to the Stone Door (Temple of Set area 1). This is the entrance to the buried temple used by the dervish cultists for their nightly rituals. For any further play at this area, particularly at night, refer to *Chapter 10: Temple of Set* for the appropriate maps and encounter descriptions.

The inscriptions on the monolith may be deciphered carefully if one hour is spent at the task. They are reproduced as Inscription 9A on the reverse of the DM's fold-up map. The translation is:

This oasis, guarded by the white palm, belongs to all who enter. This we claim in the name of the many gods.

Doing this will bring the inspecting PC to the attention of the dervish cultists. If the DM desires, this can influence the interaction between the party and Korus Eikoth; it may even cause an assassination or abduction attempt on the offending PC by the cultists.

8. The Sandvoyagers Compound

Amid the lush grasses and palms of the Oasis, a wall of white, lime-covered bricks fortifies a compound. Two great doors of palm trunks lashed firmly together stand at the west end of the 320-foot-long by 120-foot-wide encircling wall. The wall is capped by one-inch long spikes with a strange green tinge.

During the day, a random encounter will occur within 200 feet of the compound on a roll of 1-4 on 1d6. At night, an encounter will occur within 100 feet of the compound doors on a roll of 1-2. For further play in this area, refer to the Encounter Area descriptions and maps for *The Sandvoyager Compound*.

The spikes are poisoned. If a PC is impaled by one, it gives 1d4 points of normal damage and the victim must save vs. poison or be paralyzed for 1d10 turns.

Nomad Camp Encounter Areas

For play in this area, use Map 9-2 in the *Map Booklet*.

1. Camp Perimeter

The green and red cloth bands are 15 inches wide. They are suspended only inches above the sand. The green is 50 feet from the nearest tent, and the red 20 feet closer. Several pairs of guards patrolling on horseback maneuver between the two, flicking them with long sticks every once in a while, probably to keep off blowing dust.

The green gives off a distinct odor, sharp and biting, noticeable from 20 feet away. The red also gives off an odor, but one more like kerosene than anything else. Horses and camels will be reluctant (+3 on reaction roll) to cross these bands because of the odor. The green band acts as an insect and spider repellent and is harmless. When the red band is set afire it will burn fiercely. The camp will be encircled by a non-magical flame that will flare for three turns, doing 2d6 points of fire damage to all creatures passing through.

One of the two pairs of mounted guards will be encountered on a roll of 1-2 on 1d6 during the daylight hours. One of the four pairs will be encountered on a roll of 1-4 on 1d6 during the night. They will attack immediately if the encampment is attacked.

4 Guards: AC 4; MV 12"; F 4; hp 24,18,37,24; #AT 1; D 1d8+2; AL LN.

Horses: AC 7; MV 24"; HD 2; hp 12 each; #AT 2; D 1-4/1-4; AL N.

2. Camp Entrance

The four robed guards at the 30-foot wide entrance to the encampment bear scimitars. They appear to be alert and watchful. Every few minutes one speaks in a low voice to the two large dogs pacing restlessly at his feet.

4 Guards: AC 4; MV 12"; F 4; hp 32,26,28,25; #AT 1; D 1d8+2; AL LN.

2 War Dogs: AC 6; MV 12"; HD 2+2; hp 13,15; #AT 1; D 2d4; AL N.

3. Standard Nomad Tent

This tent has three sections. The main central section is flanked by two smaller chambers, separated by hanging silk.

Each tent has 1-2 male Durpari, 2-4 female Durpari, and 0-2 slaves. There is a 75% chance that any slave encountered is a female. In each tent there are 4d12 cp, 3d6 sp and a 25% chance of 2d6 gp. The women usually wear various forms of jewelry. This will be worthless 90% of the time and valuable 5% of the time. If valuable, there will be 1-3 pieces worth 5d10 gp each.

Male Nomads: AC 9; MV 12"; F 3; #AT 1; D 1d8; AL LN.

Female Nomads: AC 10; MV 12"; F 2; #AT 1; D Unarmed; AL LN.

Slaves: AC 10; MV 12"; F 1; #AT 1; D Unarmed; AL N.

4. The Sheik's Tent

The largest tent in the camp, made of multi-colored cloth that flutters in the desert breeze, is easily twice or three times as large as any other. Two large human figures stand with arms folded by the tent's flap opening. Each wears chain and carries a shield; scimitars and composite bows complete their battle gear.

Four of the bodyguards are on duty at all times. Two stand guard at the entrance to his tent and two stand behind him wherever he may be. The guards of the sheik who watch the entrance will not allow anyone to pass unless the sheik himself permits it. When the sheik is present, there are two more bodyguards just inside the tent flap, in the Main Audience Chamber.

Two of the sheik's six personal bodyguards are cult members and party to the plot to assassinate the sheik. They have been smart enough and lucky enough to conceal this, however, and so the sheik trusts them implicitly. They await the sheik leaving the compound, for then they mean to assassinate him. Whenever the sheik's bodyguards are encountered, roll 1d6; on a 1 or 2, the bodyguards encountered are the cultists.

6 Bodyguards: AC 4; MV 12"; F 4; hp 35 each;

#AT 1; D 1d8+2; AL LN (LE). They wear chain and carry a shield, using a scimitar or a composite bow. Each has an *arrow* +1 given him by the sheik as a token of his esteem.

For play inside the sheik's tent, use the map for it in the *Map Booklet*. There are six sections to this tent. The Main Audience Chamber is reached through the tent flap. By far the largest chamber is the sheik's Sleeping Chamber that occupies the entire rear. To the right, looking from the door, are the quarters of the sheik's slaves and wives. To the left are the quarters of the sheik's bodyguards and a storage/food preparation chamber.

3a. Sheik's Main Audience Room

Rich silk pillows and mats have been cast upon the beautiful rugs in this 30-foot wide by 40-foot deep chamber. Silks drape from the ceiling and hang down to form walls, obscuring any doors.

If the PCs have been brought before the sheik, read the additional description in the special encounters section of *Expected Play*. If the sheik is in his tent, there will be two bodyguards on duty here.

3b. Slaves' Quarters

Sleeping mats for four and personal belongings fill this chamber. It obviously is servant's quarters.

There are four girls, slaves since birth, who willingly and eagerly serve the sheik. He is a gentle and kind master, generous in his gifts. Though three are of modest intellect, one is very perceptive, bright, and fiercely loyal. Named Sothal, she is the sheik's favorite. For details on this important source of information for the PCs, see the section on *Major NPCs*.

Slave Girls: AC 10; MV 12"; F 2; hp 9,12,13,16; #AT 1; D Unarmed; AL N.

3c. Harem

Swathed in multi-colored silks, this chamber is perfumed by the incense that wafts from the golden brazier and by the perfumes of the three veiled women who lounge on the sumptuous pillows. The floor is covered by several rugs.

The women are the three wives of the sheik. There is a box hidden in a hole dug beneath the center rug; the box contains jewelry worth 600 gp.

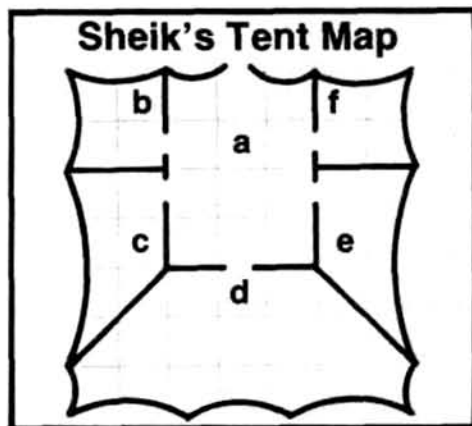

3 Wives: AC 10; MV 12"; F 1; hp 5,3,4; #AT 1; D Unarmed; AL LN.

3d. Sheik's Sleeping Chamber

The large sleeping chamber is filled with fancy clothes and pillows of satin. In the center of the mats covering the floor is a large mat for sleeping. Strange writings are found on the walls.

Those entering the chamber encounter the *glyphs of warding* on the walls, roof, and entrance immediately. Each surface has its own glyph, which gives 12 points of electrical damage to each person passing through its zone of protection.

A large chest is buried one foot beneath the sheik's sleeping mat. It is protected by both a *glyph of warding* that causes blindness and a poison needle on the lock. The chest contains 3,000 sp; 1,000 ep; 4,000 gp; 30 gems worth a total of 2,000 pp; a jeweled scepter worth 1,000 gp; and a *decanter of endless water*.

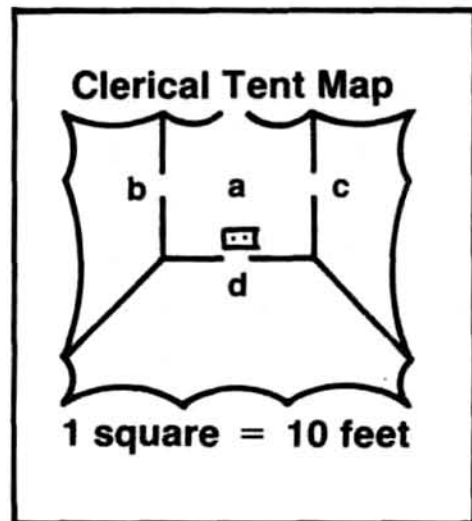

3e. Storage

Within this chamber are 12 chests, arrayed neatly against the walls, forming flat workspace. Foodstuffs and cooking utensils are neatly arranged on their upper surfaces.

Inside each chest will be found food, clothing, tools, furnishings, and utensils. None of these have any special value.

3f. Bodyguards' Quarters

Within this 10-foot-square chamber there are sleeping mats for six people. Two of them are occupied. The clothes and gear proclaim this to be the quarters of the sheik's bodyguards.

Two bodyguards of the six are off duty at any one time. The location of these off-duty guards may be determined by rolling d100 and consulting the following table:

1-40	Quarters
41-70	Sandvoyagers Compound
71-90	Nomad Camp
91-100	Oasis

If they are within the compound, the bodyguards will be either at the bazaar or at Hogan's Bar. If they are within the camp, they will be within easy hailing distance.

6 Bodyguards: AC 4; MV 12"; hp 35 each; #AT 1; D 1d8+2; AL LN (LE). They wear chain and carry a shield, using a scimitar or a composite bow. Each has an *arrow* +1 given him by the sheik as a token of his esteem.

4. Clerical Tent

A plain, dull green tent stands to one side. The tent flaps are open and inviting.

This is the main worship area of the nomads, and the residence of Nadron Ilanis, Cleric of Anu, and his two assistants Larith and Baris. Though he rarely speaks to outsiders, Nadron can be an important information source if the PCs ask him about Hassan's bride. For details, see the section on *Major NPCs*.

For further play inside the Clerical Tent, use the map for it in the *Map Booklet*. This tent has a central worship chamber separated from three side chambers. To the rear is Nadron's Chamber. To the right, looking from the tent's entrance flap, is the storage/food preparation area. To the left are the quarters of Nadron's two assistants.

4a. Central Worship Chamber

A silver statue rests atop a circular stone platform in this otherwise plain room. A single hooded figure in white robes stands with his back to the tent entrance.

There is a priest here at all times. It will be Nadron 50% of the time. The priest must be dealt with before the idol may even be approached. The statue, of solid silver worth 3000 gp, is attached to the altar and their combined weight is 500 lbs. (5,000 gp weight). The statue cannot be removed from the altar unless a key is used to open a hidden lock at the back of the statue. The key is carried by Nadron at all times.

4b. Storage / Food Preparation Chamber

About the room, set on several chests, in neat piles are found containers of food and drink, cooking equipment, and other items.

The chests are empty.

4c. Sleeping Chamber

This small chamber has two sleeping mats on the floor. There are two chests and personal belongings obviously owned by a cleric.

This chamber is the residence of Larith and Baris, the two assistants of Nadron. They are dedicated servants and do not involve themselves with the politics or the gossip of the camp. There is a 75% chance that this room will be occupied by one of them. If Nadron is in the Worship Chamber, there is a 50% chance that both are present here.

Larith: AC 5; MV 12"; C 2; hp 13; #AT 1; D 1-6; AL LN. He can cast *cure light wounds* (x2), *command*, *light*, *purify food and drink*.

Baris: AC 5; MV 12"; C 2; hp 16; #AT 1; D 1-6; AL LN. He can cast *cure light wounds* (x2), *command*, *light*, *purify food and drink*.

d. Nadron's Chamber

A sleeping mat, two large, open chests containing robes, and a personal altar sparsely furnish this austere chamber.

Immediately upon entering, every PC who comes into this chamber will take 12 points of electrical damage from one of the five *glyphs of warding* that are fixed to the four walls and

Second Son's Tent Map

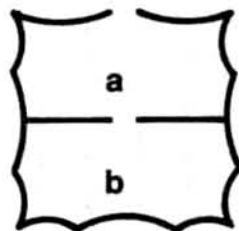

ceiling. A chest is buried in a shallow hole under Nadron's sleeping mat. It is protected by a hooded cobra that hides in the trunk and will attack whenever the trunk is opened. Nadron uses *speak with animals* and *command* to ward it off when he opens the chest. The chest contains 1,500 ep, 600 gp, and three pieces of religious jewelry totaling 400 gp in value.

Hooded Cobra: AC 5; MV 12"; HD 2+2; hp 10; #AT 1; D 1 point + poison; AL N; SA spits poison up to 30 feet.

5. Tent of Korus Eikoth

Larger than most tents, this one seems to be made of finer material. No tent stands between it and the oasis.

This is the residence of Korus Eikoth, the younger of the sheik's twin sons. Also living here is Korus' slave girl Kerina, who could be a source of information for the PCs. Kerina will be here most of the time, except when she goes to the Oasis Pool for water. Korus will be here during daylight hours, as detailed in his description. Both of these people are detailed in the section on *Major NPCs*.

For further play inside the tent, use the Large Tent map in the *Map Booklet*. The tent flaps open onto a large central chamber, with Korus' sleeping quarters to the rear. To the right, looking from the tent entrance, is the chamber of Kerina. To the left, the storage/food preparation area. Only the Main Chamber is detailed.

5a. Main Chamber

Pillows and pieces of nomadic furniture are set about the room. A chest with ornamental fittings is against the wall.

If the PCs arrive while Korus is here, he will be lounging on pillows, eating while Kerina dances for him. If the PCs arrive when she is alone, she will be curled up on the pillows, weeping.

Kerina is frightened and will flee, crying from anyone who approaches her. She is Korus' favorite slave, but he has treated her cruelly, beating her whenever he feels like it. She will, if treated with kindness consistently, tell the following:

Korus Eikoth, dressed in dark robes, leaves the camp every night when the guards are not looking. He never returns before dawn.

Once, after he returned one afternoon, she overheard Eikoth say, "Surely the place is set, but no man knows the time when Thurnas may be trusted. May the soles of his feet be smitten by a thousand willows."

The chest has a poison needle in the lock. Inside the chest are found 200 sp, 50 ep, 50 gp, and an unmarked bottle of poison. The real treasure is buried in the sand one foot beneath the chest. Here, wrapped in a rug, is another chest containing 300 gp, 100 pp, and 8 gems worth 200 gp each. There is also a potion of *brass dragon control* and a bottle with a red liquid that seems to glow slightly. This liquid ignites and explodes when exposed to air, doing 4d6 points of fire damage within 10 feet; save vs. breath weapon for half damage.

Kerina (elven female slave): AC 10; MV 12"; F 1; hp 5; #AT 1; D Unarmed; AL LG.

6. Tent of Hassan Arslan

Near to the largest tent in the encampment, this tent is larger than most. It is made of obviously superior material, its colors as bright as the largest tent.

This is the residence of Hassan, the elder of the sheik's twin sons. He is rarely here of late, spending much time with his father or searching for his betrothed, returning her only to sleep. This is not likely to become an encounter area, and so its details are left to the DM.

Sandvoyagers Compound Encounter Areas

This enclosed area was built by the Sandvoyagers Guild to house and protect their local guildhall and warehouse. They have opened their doors to the merchants who display in the bazaar and to Happy Hogan, who runs the local tavern.

For play in this area, refer to Map 9-3 in the *Map Booklet*. The Encounter Areas are numbered from left to right, looking from the compound gate, which is left open except when the

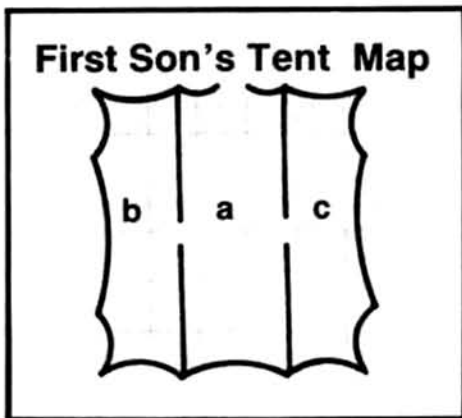

compound is under attack.

Compound Area Random Encounters

There will be encounters constantly in the area. Any of the people described in the section on *Major NPCs* may be encountered here at some time or other. To determine if an encounter occurs inside the compound walls or near the entrance, roll 1d6. During the day, an encounter will occur on a roll of 1-4; at night, an encounter will occur on a roll of 1-2. Roll 1d8 and consult the appropriate Oasis Random Encounter Table.

1. The Wayfarers' House

Standing just inside the gates of the compound is a mudbrick building with an open door. In its dusty face are small, barred windows with curtains.

1a. Common Room

This dimly-lit room is 30 feet wide by 40 feet long. An open door exits south into the compound. Two closed doors are in the northern ends of the east and west walls. The room contains benches and trestle tables, both of which are used for sleeping.

Between dawn and dusk, Roland the Minstrel will be encountered here, picking songs out on his lute and humming softly to himself. He is detailed in the section on *Major NPCs*.

The Guest Rooms (area 1b) are empty. They each contain sleeping benches along the walls. The PCs may wish to use one or two of them as a base from which to operate. Space here can be rented from anyone on duty in Happy Hogan's Desert Igloo (area 6).

2. Washing House

This 40-foot-square mud-brick building has a large, open door. Within stands a water tank, 13 feet in diameter and 4 feet high.

During the daylight hours, this building will never be empty. There will be 4d4 nomad women and 1d4 slaves washing clothes and chattering among themselves. If a PC approaches, all talk will cease.

Nomad Women: AC 10; MV 12"; F 2; #AT 1; D Unarmed; AL LN.

Slaves: AC 10; MV 12"; F 1; #AT 1; D Unarmed; AL N.

3. The Bazaar

A rag-tag collection of tents, huts, and hastily-built shelters sprawls over the area.

This is the bazaar. During the day, it will be teeming with life and energy. Everywhere there are people talking, arguing, bargaining. At one tent a rug dealer and her customer are shouting at one another and seem ready to fight. Wonderful aromas flow out of the huts where food is for sale. At night, everything will be shuttered and silent, the shopkeepers sleeping with their wares.

The DM may use this area as required to further the adventure. Information should be given out through the shopkeepers. Care should be taken that only a minimum of information be given out here: just enough to get the party moving again. The shops listed below suggest the general nature of the kinds which can be found. The price of all goods will be two to five times (1d4 + 1) the usual price.

a	Tent	Scrolls, Books and Tomes
b	Hut	Leather and Tents
c	Stall	Dried Meats
d	Stall	Fresh Meats
e	Hut	Grain
f	Hut	Rugs
g	Stall	Cloth
h	Tent	Blacksmith
i	Hut	Fortune Tellers
j	Hut	Tapestries
k	Stall	Statues
l	Stall	Trinkets
m	Stall	Fruits, Nuts, and Dates

4. Hogan's Stables

Rows of stalls line the inside of the modest brick building. Bundles of straw and hay, obviously imported, stand in one corner.

From dawn until midnight, the stable boy will

be encountered just within the double doors, where he is caring for the 2d4 animals there, many of which are owned by Happy Hogan's customers. He sleeps in the stables with the 1d4 animals that board there.

He has information, but will only impart it for a price. He knows the following:

Abu Kassar, a local merchant, stays at the tavern every night until it closes and then goes straight to the Sandvoyagers' Guildhall.

One night, while sleeping in the stable, he awoke and overheard two men talking. "Our bargain was sealed," said one. "Your man was to take the bride and deliver her to my people. Instead you betrayed us and are holding her for a larger ransom." Then the other man said, "The place is set, but show unto me the time when we shall ever work together as one I have not the girl, and would that I could fulfill our bargain. It is you who have the girl, and now, for your own purposes, you wish no part of us." It was then that the stable boy hit the gate with his foot. The gate made a noise and frightened away the two men. But the boy saw who they were: a leader of Sandvoyagers and a water bearer.

Stable Boy: AC 10; MV 9"; F 1; hp 6; #AT 1; D 1d4; AL N.

Horses: AC 7; MV 18"; HD 2+2; #AT 3; D 1-6/1-6/1-3; AL N.

5. Feed Storage Area

Dried grasses and grains are stacked in piles about ten feet across.

6. Happy Hogan's Desert Igloo

A huge dome of white-washed brick, about 80 feet in diameter, sits at the far east end of the compound. It is entered through an arch with heavy double doors at the building's west end.

6a. Hogan's Bar

This room occupies one half of the dome and ends in a flat brick back wall. Set back against that wall is a large bar about 40 feet long. Two huge mirrors flank the door behind the bar, which apparently leads to the back room. Over the door is a golden plaque. Various wicker tables and chairs are placed here and there about the room.

The bartender, a friendly and talkative Durpari, will be encountered here from about dawn to midnight, when the doors are open. He is an employee, and sleeps the night on a pallet behind the bar. He knows the standard set of rumors plus the following:

Hassan was in the bar at the time of his bride's disappearance.

Thurnas owns a sand sled and uses it occasionally.

In the evenings, he will be joined by Rose Underwood, who waits tables from the dinner hour until the bar closes. She has a room in the back. She is detailed in the section on *Major NPCs*.

Happy Hogan, the owner, will also be here from dinner until closing. He helps out behind the bar, when things get really busy. He sleeps in a small chamber in the back. He is detailed in the section on *Major NPCs*.

There are usually 1d6 patrons enjoying themselves during the daylight hours, and 2d6 here from dinner until closing. One of these will invariably look interesting to the PCs, but he will not want to speak to them; he knows nothing, anyway. Nightly, the PCs can encounter Zorath Blackblade here; he is bored.

Bartender: AC 8; MV 12"; F 2; hp 8; #AT 1; D 1d6; AL LN.

Patrons: AC 7; MV 12"; F 2; #AT 1; D 1d6; AL LN.

Happy Hogan, halfling thief, retired: AC 1; MV 9"; T 14; hp 56; #AT 1; D by weapon; AL N.

Rose Underwood, halfling waitress: AC 7; MV 9"; F 1; hp 5; #AT 1; D 1-4; AL N.

Zorath Blackblade, slaver assassin: AC 5; MV 12"; A 5; hp 19; #AT 1; D 1d6+1; AL NE; strength bonus +1 damage.

6b. Back Room

Steam rises from the kettles bubbling on the hearth in the center of the room. The room is about 30 feet square. In the eastern wall is an iron door barred shut. There is also a door in both the northern and western walls, and two doors in the southern wall.

Hogan's chef, Cookie, is slaving away at the evening's meal. He will immediately request that people entering here leave by the way they came. Cookie is loyal to Hogan and has orders to let no one come into the back room. He will yell for the Home Guard and, if necessary, attack anyone refusing to leave the room.

Cookie: AC 4; MV 12"; F 5; hp 33; #AT 1; D 1d8+2 with scimitar; AL LN.

6c. Fogli's Room

The room has a few furnishings for guests. There is a single bed, its blankets draped down over the sides.

Under the bed is a locked chest marked *Fogli Forkbeard*. It contains, beneath some clothes, 120 sp, 80 gp, and a silver dagger. The gnome, Fogli, does not really sleep here.

6d. Rose's Room

The room is filled with comfortable furnishings. A soft bed with a white covering stands next to a vanity. On the vanity is a silver comb. Paintings of two halflings hang on the wall and a handmade rug covers the floor.

The comb is worth 10 sp.

6e. Hogan's Room

The room has very few furnishings. There is a single bed, its blankets draped down over the sides.

Under the bed is a chest marked *Hogan*. It is locked because it contains 77 cp, 50 sp, and 18 gp.

7. Ancient Temple

In the center of this 40-foot-square temple, are six pillars that once supported the stone roof. The roof is now broken, and rubble litters the floor. Behind an ancient altar runes carved into the stone can still be seen.

The runes, carved in the ancient alphabet, are reproduced as Inscription 9B on the reverse of the DM's fold-up map. They may be translated as follows:

I, Martek, have laid up for you a great power and treasure for when you return to wrestle with the awakened evil.

No man knows the time, but the place is Set—not at White Palm, yet neither far from it.

8. House of the Sandvoyagers' Guild

Solid and stately, the house of the Sandvoyagers' Guild is against the southern wall of the compound. In the center of the build-

ing's northern wall are two huge double doors; they are shut. A sign near the doors reads *Guild Members Only*.

8a. Main Warehouse

Shrouded in darkness, the expanse of the vast warehouse is blocked by stacks of crates near the door. In one corner is a large sand sled with three ski runners.

The hall measures 50 feet by 60 feet. Two slaver guards wait in an alcove above the doorway. They will leap onto any PCs that enter through the doors, yelling for the help from the guards in the back (area 8c).

A trap door against the center of the west wall leads to the Recreation Room (Temple of Set area 25). This is the way the slavers enter the temple, away from prying eyes. For further play in that area, refer to *Chapter 10: Temple of Set* and the appropriate sections of the *Map Booklet*.

The crates are labeled: *dates*, *cloth*, *statues*, *coconuts*, *cutlery*, and *plates*. All are empty except the three marked *cutlery*, which contain 50 scimitars each, and the two marked *plates*, which contain 20 chainmail shirts and breastplates that have the Durpari army symbol on them.

2 Slaver Guards: AC 4; MV 12"; F 2; hp 13,15; #AT 1; D 1d8; AL NE.

8b. Records Office

The 20-foot square room is littered with papers and ledger books. One large book sits open on the desk in the center of the room.

There is a secret door at the south end of the east wall that leads to the compound just behind the temple. The book is labeled *Ledger of the Sand-voyagers Guild*. It is full of columns of numbers. Careful inspection will show two types of handwriting. Entries in the first hand indicate good profits and a healthy business. This handwriting then ends. Entries made in the second hand show that profits have dropped off sharply; these entries are obviously rigged. The first handwriting is that of Tolnus Granicus and ends when he was abducted; the new writing is that of Thurnas Netmaster.

8c. Lounge

The room measures 20 feet square. It contains a large round table and 8 stools.

If the PCs approach unannounced by the guards just inside the warehouse entrance, they will spot the eight warehouse guards inside, shooting dice. The guards will attack

immediately upon seeing the PCs or hearing the call for help from the guards at the entrance. Each owns 1d20 gp.

Guards: AC 4; MV 12"; F 4; hp 21,27,30,23,34,27,22,16; #AT 1; D 1d8; AL NE.

8d. Kitchen

The dim and musty room is lit only by the glow of coals from a dying fire. A lone, slim girl struggles to her feet.

A slave girl is chained to the floor. The slave girl, kidnapped from a caravan going to her native land, has been forced to cook for the guards here. She knows that:

Tolnus Granicus is not just ill but is being held captive in the cellars below the Guildhall.

Starting from the cellar, the slavers have been digging underground, looking for a fabulous treasure. So far they have not found it.

There is a trap door in Thurnas' Chamber (area 8e) that leads down to the cellar and diggings.

Slave Girl: AC 10; MV 9"; F 1; hp 4; #AT 1; D Unarmed; AL LN.

Chapter 10: Temple of Set

Background

The Legend

This ancient temple was built even before Martek's time 1000 years ago. Old even then, the temple was used by Martek to house one of the Star Gems. Forseeing that there would be need of a way to help contain the efrete Khalitharius, he provided the clue here that would guide the heroes of the future to do this. Inscribed here are instructions for the use of the medallion he gave to the sheik of the Oasis, and how to put it together with the palm sign he had appear on the sheik's first wife and the intended first bride of the sheik's heir.

The Situation

Both the dervish cultists and the slavers of the Sandvoyagers' Guild are using this ancient underground complex. The cultists enter through the secret door in the oasis monolith. The slavers conduct mining operations in their area and use part of the temple as a prison. The areas are connected by a single secret passage (area 11d). Neither the cultists nor the slaves have discovered the secret passage, or the fact that they are both using the temple. The cultists have imprisoned the captain of the slavers guards here, and the slavers have imprisoned the former Guildmaster here. Furthermore, the slavers have provided residence for several drow in their part of the temple, as well as for the goblin miners and their bugbear guards.

Dervish Cult Ceremony

The cultists hold rituals in the temple every night between midnight and 3am. They pass through the secret door in the monolith and descend a flight of stairs. When they reach the entrance, a password summons a zombie to raise the door. Upon entering, the cultists undergo a purification ceremony to prepare themselves for their evil rites. Once this is done, they speak three words at a portal and enter the main chamber.

Expected Play

If player characters are inside the cult area of the temple between midnight and 3am, the NPCs that they meet will be taking part in the rituals. Player characters can learn the secret passwords by disguising themselves and following the real cultists through this area.

Because the entrance through the Monolith (Oasis area 6) is easier to find, the Encounter Areas have been numbered upward from that place. When playing this area, use the map to the Temple of Set, the colored Map of Martek, and Inscriptions 10A-C from the reverse of the DM's fold-up map.

Player Map

In the unexplored area is a fragment of a map

made by Martek showing the northern part of the Desert of Desolation, including Medinat Muskawoon, the riverbed of the River Athis, the Oracle Stones of Martek, and the Pillars of Martek. This is Map 6-3 on the colored map sheet. It should be given to players when the PCs find it.

Random Encounters

While the party is in the temple, the DM should check for random encounters once every three game turns. A roll of 1 on 1d6 indicates that an encounter takes place, and then a roll on 1d8 determines which encounter occurs. In determining which encounter, use the Cult Area Random Encounter Table for all random encounters in the cult area of the temple; use the Slavers Area Random Encounter Table for encounters in the slaver-controlled areas.

Cult Area Random Encounter Table

- 3d6 Zombies: AC 8; MV 6"; HD 2; #AT 1; D 1d8; AL N.
- 1d6 Dervish Cultists: AC 7; MV 12" F 3; #AT 1; D 1d4; AL NE.
- 1d4 Giant Spiders: AC 4; MV 3"/12"; HD 4+4; #AT 1; D 2d4 + poison; AL CE.
- 1d10 Dervish Cultists: AC 7; MV 12"; F 3; #AT 1; D 1d4; AL CE.
- 1d6 Giant Poisonous Snakes: AC 5; MV 15"; HD 4+2; #AT 1; D 1-3 + poison; AL N; SA poison paralyzes for 1d10 turns.
- 1-2 Mummies: AC 3; MV 6"; HD 6+3; #AT 1; D 1d12 + disease; AL LE; SA Fear; SD +1 or better weapon to hit, half-damage from weapons.
- 1d12 Zombies: AC 8; MV 6"; HD 2; #AT 1; D 1d8; AL N.
- 2d6 Dervish Cultists: AC 7; MV 12"; F 3; #AT 1; D 1d4; AL CE.

Slaver Area Random Encounter Table

- 2d4 Slaver Guards: AC 4; MV 12"; F 4; #AT 1; D 1d8; AL NE.
- 1d4 Giant Spiders: AC 4; MV 3"/12"; HD 4+4; #AT 1; D 2d4 + poison; AL CE.
- 1D10+2 Giant Poisonous Snakes: AC 5; MV 15"; HD 4+2; #AT 1; D 1-3 + poison; AL N; poison paralyzes 3d10 turns.
- 1-2 Mummies: AC 3; MV 6"; HD 6+3; #AT 1; D 1d12 + disease; AL LE; SA Fear; SD

+1 or better weapon to hit, half damage from all weapons.

- 1d12 Slaver Guards: AC 4; MV 12"; F 4; #AT 1; D 1d8; AL NE.
- 1d6+1 Servant Bugbears: AC 5; MV 9"; HD 3+1; #AT 1; D 2d4; AL CE.
- 1d6 Slave Girls: AC 10; MV 12"; F 2; #AT 1; D Unarmed; AL LN.
- 1d6 Slaver Guards: AC 4; MV 12"; F 4; #AT 1; D 1d8; AL NE.

Dervish Cult Chambers Encounter Areas

1. The Stone Door

The steps down into the monolith descend 70 feet to a 30-foot long passageway carved from the stone. This passageway ends at a stone door. Drawn on the door is an image of an evil jackal head on the shoulders of a man. The eyes are sinister red points of light.

The stone door is one inch thick and cannot be physically forced open. The door is raised by a zombie on the other side if the words, "Open in the name of the Great One" are called out. Calling out "Close in the name of the Great One" will cause the zombie to lower the door.

From midnight to 3am there will be 1d4 dervish cultists standing before the door. They will give the password loud enough so that anyone within 10 feet of the cultist nearest the door can hear them. Once the door is opened, they will enter the next room and the zombie will lower the door. A second group will come down the stairway 1d10 rounds later and approach the door.

Dervish cultists: AC 7; MV 12"; F 3; #AT 1; D 1d4; AL LN.

2. Temple Entry

The long, damp room is decorated with tapestries covering the east and west walls. A large wheel with a winch is mounted on the north wall. Pegs and hooks are mounted on the north and south walls.

Turning the wheel clockwise will lower the door into place in one round. Turning the wheel counter clockwise will raise the door in one round. From midnight to 3am, a zombie will be manning the wheel to respond to the password. Before and after this time, the room

will be vacant, the zombie having returned to the Carnivorous Cavern (area 3).

Zombie: AC 8; MV 6"; HD 2; hp 12; #AT 1; D 1d8; AL N.

3. Carnivorous Cavern

Within this small, dark cavern stand several figures, swaying from side to side.

Four (three if one zombie was in the Temple Entry) zombies are standing in this room. They will not attack unless their room is entered or the *glyph of warding* on the Door of Warding (area 5) goes off.

Zombies: AC 8; MV 6"; HD 2; hp 12,10,8,(12); #AT 1; D 1d8; AL N.

4. Followers' Purification Room

The walls of this room are painted to depict terrible creatures marching to war. In the middle of the floor are three wading pools, three feet long east to west by six inches deep. The northernmost pool holds a perfumed, transparent liquid with a green tinge. The middle pool contains a deep red liquid, and the southernmost pool contains a clear liquid.

The worshippers are required to wade through these pools as a rite of purification before they worship their evil deity. There is nothing special about any of the liquids.

5. Door of Warding

The cult members will say the passwords as in Trap/Trick below before passing through the arched door. All cultists know the passwords into this part of the complex. Player characters who follow the cultists will learn the passwords.

Over the doorway between this room and the Followers' Purification Room (area 4) are 3 glyphs of warding, one on each wall and one on the floor. Unless the words "Seti," "Minion," and "Nol-anka" are spoken before a character passes, the glyphs will be discharged. In addition to giving damage, this will summon the zombies from the Carnivorous Cavern (area 3) and, if between midnight and 3am alert the worship group in this room to the presence of strangers. The floor glyph will cause blindness, and the wall glyphs will do 10 points of fire damage each.

6. Outer Temple of Set

Two rows of thick pillars covered with chaotic designs support the 50-foot tall ceiling of this hall. At the north end of the chamber is a huge stone idol of a man with the sneering head of a jackal. The eyes of the idol look like large red gems. The idol's hands rest on his knees. Before the massive idol, a pit 10 feet across glows with a pulsating red light.

From midnight to 3am, there will be 13 people here, standing around the pit. All wear red robes with hoods that cover their faces. Four of them stand beside the idol, two on each side facing south, while the other nine face the pit looking north. The four around the pit will be Corga Kazan, Korus Eikoth, and two acolytes; the remainder are dervish cultists.

If anyone attempts to pry the gemstones, which appear to be worth 10,000 gp each, from the face of the statue, its 10-foot long arms will animate and attack as a 16 + HD monster with an AC of 0 and 80 hp each. Each arm does 4d10 damage points. Once removed, the stones will start to glow brightly and give off intense heat, causing 6d6 damage points to all within 10 feet of them. After one turn, the stones will melt and the heat will disappear. If an *ice storm* or *cone of cold* is used on the gems, they will become cold immediately and retain their full value.

From the depths of the pit comes a faint, pulsating red light. The pit appears to be bottomless. This is an illusion, for the pit is actually only 100 feet deep. The illusion is placed at the 50-foot level and a character lowered on a rope farther than this will see the pit for what it really is. At the 60-foot level a pair of secret doors are located on the east side. The doors open outwards. They lead to a smooth, but climbable, chute leading steeply upwards to a horizontal, solid stone ceiling. This ceiling is the dropping floor in Cross and Double Cross (area 9); the trap cannot be triggered from here. A large number of skeletons are at the bottom of the pit. Small pieces of jewelry worth a total of 300 gp are scattered among the skeletons.

Corga Kazan, dervish cleric: AC 5; MV 12"; C 5; hp 27; #AT 1; D 1d6 + 2; AL LE. He carries the following spells: *command*, *cure light wounds*, *darkness*, *light*, *sanctuary*, *hold person* twice per day, *silence 15' radius*, *know alignment*, *dispel magic*. He is armed with a *mace* + 1. For more details, see the section on *Major Non-Player Characters* in Chapter 9: Oasis of the White Palm.

Korus Eikoth, second son of the sheik: AC 1; MV 12"; F 7; hp 45; #AT 3/2; D 1d8 + 4; AL

LE; strength bonus +2 to hit, +4 damage; S 18/88; I 11; W 9; Dex 15; Con 15; Ch 10. Korus is armed with a *scimitar* + 1 and wears *chainmail* + 2. He also has one *potion of ESP* and six *arrows* + 1. For more details, see the section on *Major Non-Player Characters* in Chapter 9: Oasis of the White Palm.

2 Acolytes: AC 6; MV 12"; C 2; hp 11,6; #AT 1; D 1d8; AL LE. Each has the following spells: *darkness*, *command*, *cause fear*, *cause light wounds*.

Dervish cultists: AC 7; MV 12"; F 3; hp 15,15,14,20,20,10,12,23,13; #AT 1; D 1d4; AL LN.

7. Acolytes' Quarters

This 20-foot square room is sparsely furnished with three sets of rude desks and beds and three small chests.

The acolytes will be here except from midnight to 3am, when they will be in the Outer Temple (area 6). They are fiercely dedicated to their cause and religion and would rather die than betray them.

The chests contain only old clothes, socks, religious books, etc. An ancient wall safe is concealed behind a small secret door in the east wall. Four small boxes are inside, one each of gold, silver, lead, and obsidian. The obsidian box contains a *phylactery of monstrous attention* and a *peript of foul rotting*; it is guarded by a *glyph of warding* that will cause 2d10 points of lightning damage when touched, and only Corga Kazan knows that the word *Tabang* neutralizes the glyph. The gold and silver boxes contain *incense of obsession* while the lead box contains *incense of meditation*.

2 Acolytes: AC 6; MV 12"; C 2; hp 11,6; #AT 1; D 1d8; AL LE. Each has the following spells: *darkness*, *command*, *cause fear*, *cause light wounds*.

8. Priest's Purification Chamber

Wall carvings showing grand harvests have been defaced and scarred in this 30-foot square room. Three elaborate basins stand on decorated pedestals, each containing a different liquid. The first liquid is clear, the second liquid, which bubbles and steams, is a dull red, and the third liquid, which burns, is amber.

These basins are used in the evil priest's ceremony of preparation. The unholy water in the first basin will cause 1d6 + 1 damage points to

any paladin who comes in contact with it. The second basin contains an evil ichor that causes 2d6 damage points to neutral creatures and 4d6 damage points to characters of good alignments during each round they are in contact with it. The amber liquid is an illusion. There is a secret door in the center of the north wall.

9. Cross and Double Cross

The door opens onto a cross-shaped hall with branching corridors.

This hall is 50 feet long and the cross-hall is 30 feet long. Attempting to open either the east or the west door will activate the tilting floor trap, which will drop its victim down a slick marble chute to the east and then into a pit below the Outer Temple (area 6). This will give 8d6 damage points from the fall.

When the north door is opened, a heavy mist will roll out and down the hall at a rate of 10 feet per segment, completely obscuring vision. Simultaneously, the wight that is held behind that door will be released. The mists will remain for 1d6+5 rounds, during which time, everyone within the area, including the wight, will attack at -4 to hit.

Wight: AC 5; MV 12"; HD 4+3; hp 30; #AT 1; D 1d4 + drain one level; AL LE; SD only silver or magical weapons will hit.

10. Corga's Sanctum

The 20-foot square room is filled with an eerie red light that comes from atop a platform at the far eastern side of the room. Nine carved, circular steps lead up to the top of the platform. A strange, glowing skull gives off the red light.

Corga is likely to be found here from 3am to dawn, and then again from supertime to midnight. When he is here, there is a 70% chance he will be asleep, tired from his water-carrying labors and his clerical duties.

The skull appears semi-human but with distorted features, oversized fangs, and three short horns. It is the skull of *Garath*, an evil artifact. It has three powers, controlled by runes on the skull: it can *cause fear* as the spell (5x); it can *animate dead* as the spell (5x); and it can communicate with the Efreet Pasha Khalitharius once per month. Its powers are usable only by clerics; non-evil clerics will suffer 1d8 damage points each time its powers are used.

11. Essence of Evil

This hallway is criss-crossed with shadows that no light can banish. The air seems to

reach with icy fingers to the very bones, tugging at life itself. The floor is covered with sand and dust that filters down from the cracks in the ceiling, adding to the three-inch accumulation. Four doors lead out from this area, one to the north, one to the east, and two to the south.

This is an intensely evil area, having the following effects on beings present in it; characters of good alignment take one damage point per round; characters of neutral alignment take one damage point per turn; characters of evil alignment regain one hit point per turn; and undead regenerate one point per round. Paladins and those under *protection from evil* spells will suffer no damage. A *dispel evil* or *remove curse* spell will permanently dispel the evil effect in the corridor.

11a. Brazier of Violet Flames

In the midst of this 10-foot-square chamber, a brazier is fixed to the floor and burns with deep violet flames. There is a cabinet on one wall which openly displays branding irons and whips with steel thongs. Three skeletons hang chained to the wall, the centermost wearing the remains of rich robes, a necklace, and a pair of arm rings.

The skeletons will attack only when a party member comes within arm's reach to inspect them. The arm rings are worth 50 gp each. The necklace is a *necklace of strangulation*.

The flames in the brazier do not give off heat and do not consume air or wood. Metal placed in the flames will take on a violet glow, but it will return to normal after removal. When the flames touch living flesh, however, they will burn, doing 1d4 damage points damage in the round they are touched, 2d4 points in the round after they are touched, and 3d4 thereafter for 1d6+2 rounds. If the brazier is knocked over, the flames will spread into a fiery flood filling the room and the hall beyond at a rate of 10 feet per segment. The flames will not spread any farther than this area and will fade away two turns later.

Skeletons: AC 7; MV 12"; HD 1; hp 4,5,8; #AT 1; D 1d6; AL N.

11b. Golden Idol

Within this shadowy, 10-foot-square chamber, a circular platform 5 feet in diameter stands in the center. There is an altar against the north wall. A golden idol, 10 inches tall and shaped like a falcon, stands atop the altar.

The idol is enchanted and cursed. It looks like

gold and will radiate magic if a *detect magic* spell is used. Because of the curse, anyone who takes the idol will suffer a -4 penalty on all saving throws and to hit rolls. A *remove curse* spell will reveal that the idol is actually lead and will remove the curse from the victim.

11c. Torture Room

The 10-foot square room forms a tableau of despair. A man is manacled against the farthest wall, struggling weakly. Before him, just out of reach, stands a small, beautiful table laden with delicious food. From a goatskin bag suspended from the ceiling, a continuous thin stream of wine pours in a crimson arc to the floor. An oil lamp hangs from the ceiling at one side, its glow lighting the entire room.

The food and the wine are poisoned. The manacles are locked and the key is nowhere to be found. The prisoner, Barus Broadblade, commanded the slaver guards of the Sandvoyagers Guild, but he was overpowered three nights ago by a group of dervish cultists who brought him here. He has been tortured by Corga to find out where the Princess Shadallah is.

Barus will be suspicious of the party at first and will have to be convinced of their sincerity. If rescued, he will ask the party to give him weapons and armor. He will try to escape at the first good opportunity. He knows the following:

Corga and the dervish cultists kept asking him where the princess was. It is clear to him that the cultists apparently think that the slavers have her and that they do not have her themselves. As captain of the slavers' guards, Barus knows that the slavers don't have her, telling Corga that.

Though he was not the one who made it, he has found out that there was apparently some sort of contract between the slavers and the cultists for the kidnapping of the princess.

An efreet appeared to the cultists and showed interest in the princess, but since she disappeared the efreeti has not returned. Barus thinks that somehow the princess was a threat to the efreet, who probably has carried her off to his stronghold, the Crypt of Badr Al-Mosak.

Barus Broadblade: AC 10; MV 12"; F 3; hp 28; #AT 1; D Unarmed; AL NE; strength bonus +1 to hit, +3 damage.

11d. Platinum Idol

This shadowy 10-foot-square room contains a 5-foot-diameter platform in the center. Atop an altar against the east wall sits what appears to be a platinum idol with jeweled eyes. The idol is that of a monkey with its paw over its ears.

The idol is part of the altar and cannot be removed. Pressing the left eye-gem of the idol will cause the secret door to open. Pressing the right eye-gem triggers a *polymorph other* spell. The person pressing the eye must save vs. wands or be polymorphed into a monkey. A polymorphed character will then have to throw percentile dice to determine whether he retains his own memory. There are currently three spells left in the idol. After the three spells are used up, pressing the right eye-gem will do nothing.

Unexplored Temple Encounter Areas

12. The First Test

The room is completely filled with spider webs with the exception of a path to an arched opening to the north. The path is 6 feet high and 2 feet wide.

There are two giant spiders that await the party as they traverse to the arched opening to the north. They will attack any non-Drow entering the area. The webs may be burned away to reveal the inscription on the walls. Written in the ancient alphabet, this is reproduced as Inscription 10A on the reverse of the DM's fold-up map; it is translated as follows:

Beware ye the wrath of Set and his minions, for before you lies the gate to this Kingdom of Evil, and those who make the journey never return.

Giant Spiders: AC 4; MV 6"/12"; HD 4+4; hp 24,18; #AT 1; D 2d4 + poison; AL CE.

13. The Second Test

In this dark chamber, the floors are swept and tapestries are hung on the walls. It is obvious that the chamber has been recently occupied. The tapestries show spiders spinning a web over all the kingdoms of man. At the far north end, opposite the entrance, there stands a door of solid steel. The giant head of a jackal is molded in its center.

The jaws of the jackal are open, as though attacking. In the back of the mouth, a small

keyhole is visible. The mouth will animate and bite anyone attempting to pick the lock, causing 1d6 damage points at each attempt. The biting can be prevented by blocking the mouth open. As the door is triple locked, to open it will require two separate *knock* spells or three successful lockpick attempts for thieves.

14. Inner Temple of Set

This huge chamber throbs under the pulsing, red light cast up from a 10-foot-diameter pit, which throws it in waves from beneath a gigantic statue. The shadows cast by the light from below give a sinister appearance to the jackal-headed idol that sits cross-legged, holding a large altar bowl that is giving off smoke. The jackal head's gem-eyes glitter in the dim light. Along the walls can be seen inscriptions written in the ancient alphabet.

The smoking bowl is harmless, but the idol holding it is not. It is intelligent and its eyes have the power of *gems of true sight*. It will wait until any character has gone halfway across the room, and then it will cause the steel door to close and lock behind the PC. After the door closes, its eyes will glow dimly red and it will begin to summon monsters until there is one for each person, PC or NPC alike, in the room. The monsters will fight to the death. The summoned creatures will try to force the party into the pit. Each time a monster scores a hit, the character hit must make a Strength check or be forced 2 feet closer to the pit. Each time a monster is hit, it must roll its AC or greater on 1d10 or be forced away from the pit 2 feet. The results are cumulative and must be within the limits of the room, i.e., a monster cannot be forced back from the pit farther than the walls will allow. Characters who are closer than 2 feet to the pit when their Strength check fails will fall into the pit with their foe, still locked in combat.

The monsters will be summoned in the following order:

1. Zombie: AC 8; MV 6"; HD 2; hp 9; #AT 1; D 1d8; AL N.
2. Ghoul: AC 6; MV 9"; HD 2; hp 9; #AT 3; D 1-3/1-3/1d6 + paralysis; AL CE.
3. Ghast: AC 4; MV 15"; HD 4; hp 18; #AT 3; D 1d4/1d4/1d8 + paralysis and stench; AL CE.
4. Shadow: AC 7; MV 12"; HD 3+3; hp 16; #AT 1; D 1d4+1 + strength drain; AL CE.
5. Necrophidius: AC 2; MV 9"; HD 2; hp 9; #AT 1; D 1d8 + paralysis; AL N; SA sway-movements have hypnotic effect.

6. Wight: AC 5; MV 12"; HD 4+3; hp 17; #AT 1; D 1d4 + drain one level; AL CE.

7. Mephit, Smoke: AC 4; MV 12"/23"; HD 3; hp 14; #AT 2; D 1-2; AL LE; SA Smoke attack every 2 rounds, doing 1d4 damage points and blinding victim for 1-2 rounds, no saving throw applicable, 20-foot range; SD *invisibility*, *dancing lights* once per day, *gate* 1-2 smoke mephits once per hour, 20% chance of success.

8. Shadow Demon: AC 1; MV 12"; HD 7+3; hp 35; #AT 3; D 1d8/1d6/1d6; AL CE; SA +2 to hit. It can cast *darkness* 10' radius and *fear* once per day; SD half damage from attacks, immune to fire, cold, and lightning, turned as special undead, 50% chance of going undetected.

The creature will cast *darkness* and *fear* as it emerges from the pit. The PCs will notice a darker shape will be seen amid the darkness, giving the appearance of huge wings and dim red eye-slits as it attacks. If illuminated by a torch, the demon will become AC 5 and will have a +1 bonus to hit; attacks upon it cause normal damage. If a *light* spell is cast upon it, the demon will suffer 1d6 damage points per level of the caster, as if struck by *fireball*.

If the gems are removed, which will take 1d10 rounds to accomplish, or if they are destroyed (AC -2; hp 10 each), then the monsters remaining will stop their attack and flee back into the pit. Each damage point done on the eye gems reduces their value by 50%. If removed intact they are worth 10,000 gp each.

The pit tunnels straight down as far as one can see. At the bottom is a pulsing red glow. At the 100-foot level, there is a dimensional gate that leads to the first plane of Pandemonium where these evil creatures summoned dwell. The gate prevents any being from coming unbidden but will let pass anything (or anyone) that is going down. Thus anyone passing the 100-foot level is lost to Pandemonium.

The inscription on the walls are reproduced as Inscription 10B on the reverse of the DM's fold-up map. It says:

Beware ye the Eyes of Set, for they are all-seeing and all-knowing. He casts his gaze upon thee and knows thee, and knowing thee does see to his minions.

15. Tapestry Room

Strands of torn and rotted cloth hang limply from cables 2 feet below the ceiling to within 6 inches of the floor.

Close examination of these strands will reveal

that the cloth was once tapestries, now well rotted with age.

16. Forbidden Stair

An old stone staircase, covered with dust and sifted sand, goes down into the earth.

The stair is 90 feet long. There is a trap half-way down the stair, activated by weight. When activated, a 30-foot length of stairway will suddenly give way from 10 feet ahead of the party member farthest forward to 20 feet behind him. Each character affected must make a Dexterity check or fall into the pit below the stairs. Those who succeed in this check have held onto the hinged staircase and may attempt to climb out.

To make matters more difficult, smoke from the pit below will fill the stairway and pit. The smoke is toxic and those breathing it will take 1d8 damage points per round, and characters will not be able to hold their breath for more than 1-3 rounds. The smoke will take 1d10 rounds to clear.

Those falling will take the smoke damage and land on soft sand some 50 feet below the stairs. The cavernous pit, still obscured by smoke, holds 20 skeletons, each attacking with a spear. The sand will act as a sinkhole. (See Chapter 6: Desert of Desolation, for details on Sinkholes, area 6.)

Skeletons: AC 7; MV 12"; HD 1; hp 3 each; #AT 1; D 1d6; AL N.

17. Library

The dark room is lined with shelves an old scroll cases made of bone. A large pile of ash is in the center of the room. Soot covers the walls and ceiling.

A bone scroll case will be found amidst the ashes along with the Star of Khan-Pelar.

The scroll case is old and sealed, with runes covering its exterior; within it is a map also covered with runes. The runes on the case, written in the ancient alphabet, are reproduced as Inscription 10C on the reverse of the DM's fold-up map. They translate as:

Property of the good mage Martek, do not open. Most Secure

The map, which is reproduced on the colored map sheet, dates from Martek's time, and some of the locations are now in ruins. This map is Map 6-3 on the colored map sheet. It shows the northern Desert of Desolation, including the location of Medinat Muskawoon. It actually is part of the same map given the PCs by Aman Al-Raqib, the mage in Bralizzar. The inscrip-

tion on the back of the map (printed on the back of map 6-3) translates as follows:

In Phoenix did I, Martek, Archmage of the land, seal up a prince of the Djinn, that in the days ahead which I do foresee, when the Evil One is loosed, the powers of good might be put to the test against the evil. The path and the way have I entrusted to the Pharaohs and their wives, that each might hold a part of the key and together know when to unlock the power of this goodly Djinn. The time is yet unknown, but the place is this place of Set under the protecting Phoenix.

Slaver Chambers Encounter Areas

18. Conference Room

Seven figures lie huddled near the west wall in this room dimly lit by candles. The south wall lies crumbled and broken. A tunnel runs toward the south. A door opens into the center of the north wall.

Seven goblin miners are asleep here.

Goblins: AC 6; MV 6"; HD 1-1; hp 2,1,7,3,1,5,4; #AT 1; D 1d6; AL LE.

19. Tunnels

These tunnels run back into diggings and end suddenly. The slavers have been looking for other ruins.

20. Storeroom

Lit by candles, the south half of the room is piled high with crates and chests. Large figures lie on mats in the northeast corner.

Three bugbears, the guards for the goblin miners when they are digging, are asleep here. They have a 2 in 6 chance of waking each round the party is in the area. The crates and chests contain mining tools. There is a trap door in the ceiling which leads to Thurnas Netmaster's room in the Sandvoyagers' Guildhall (See Chapter 9: Oasis of the White Palm, Sandvoyagers Compound area 8e).

Bugbears: AC 5; MV 9"; HD 3+1; hp 16,11,18; #AT 1; D 2d4; AL CE.

21. The Long Hall

A 10-foot wide corridor runs east and west a distance of 80 feet, well lit by glowing balls of light. Near the center of the hall,

two doors face each other, opening to the north and south. Each door is decorated with a carving of a bald man with an earring in his right ear.

Any random encounter monster who is a friend of the slavers will say *Selamat* before passing down this hall. This wards off the *magic mouth* cast upon the carving on the northern door. It is set to yell "Help Help Intruding infidel dogs Help Help Tourists Tourists" whenever anyone walks past without first calling out the password.

22. Mystic Magician

A large desk covered with ancient books and papers dominates the room. A crystal ball lies at one corner of the desk and a large quill pen at another.

There is a scroll with three 3rd-level magic-user spells on the table. The scroll was written at the sixth level of spell use. The DM should choose three spells that would benefit the party at this point. The crystal appears dark and smoky within. It is only glass and of little value except as a prop for the old magic-user who owns it.



23. Guard's Hall

In the center of the south wall of this 30-foot-square room is a tunnel leading south.

Kalitrates, a drow fighter working with the slavers, is standing guard here. He will attack immediately upon noticing the PCs. He carries 23 pp and 30 gp in his backpack.

Kalitrates (drow elf): AC 2; MV 12"; hp 19; F 3; #AT 1; D 1d6+1; AL CE; SA See below; SD +2 on all saves; MR 56%.

Kalitrates is armed with a *short sword* +1, *dagger* +1, *chain mail* +1, *small shield* +1, and a single javelin coated with drow sleep poison (save vs. poison at -4 or sleep for 1d10+2 rounds). He also wears a *cloak of elvenkind* and *boots of elvenkind*. The cloak gives a +6 to saving throws against fire attacks. All these items will become useless immediately if exposed to sunlight. Kalitrates has 12" infravision and can use the following spells once per day: *dancing lights*, *darkness*, *faerie fire*.



24. Zomara's Cave

The excavation opens suddenly into a cavern roughly 30 feet square. The entire ceiling is covered with a decorative web of spider silk. Silk tapestries hang on the rough-hewn walls and show spiders amid decorative patterns. A rich-looking bed covered with silks and furs stands against the opposite wall. Scattered about the room are a marble tub, a desk and two chests. A heavy cord hangs next to the head of the bed. A lone, dark and slender figure moves on the bed.

This is the chamber of Zomara, a drow cleric working with the slavers. She is in here resting. When the party enters, roll for initiative as normal.

Zomara's first act will be to release a large, weighted net from its camouflaged position in the webs over the doorway. It will drop to cover a 7-foot-square area immediately in front of the door. All characters underneath must make a dexterity check or be caught in the net. Netted characters can cut themselves free in 1d4+1 rounds or burn the net in 1 round. Burning the net causes 1d4 damage points to all caught in it.

Zomara's second action will be to call for help. At her command, eight large spiders will emerge from behind the tapestry and attack when ordered.

In the locked chests are found clothing and

personal items, but nothing of value. Within the pillow are ten 50-gp gems, five 100-gp gems, and one 5,000-gp gem.

Zomara (female drow): AC -2; MV 12"; C 8; hp 48; #AT 1; D 1-6+3; AL CE; SA See below; SD +2 to all saves; MR 66%.

Zomara is armed with a *mace* +3, *chain-mail* +3, and a *small shield* +3. She also wears a *cloak of elvenkind* and *boots of elvenkind*. The cloak provides a +6 bonus to saving throws vs. fire. All these items will become useless if exposed to sunlight.

Zomara's natural abilities are: *dancing lights*, *faerie fire*, *darkness*, *detect magic*, *know alignment*, *levitate*, *clairvoyance*, *detect lie*, *suggestion*, *dispel magic*. Her spells as a cleric include: *command*, *cure light wounds*, *sanctuary*, *hold person* (x2), *silence 15' radius*, *resist fire*, *find traps*, *glyph of warding*, *create food and water*, *animate dead*, *cure serious wounds*.

Large Spiders: AC 8; MV 6"/15"; hp 2,4,9,5,7,3,4; #AT 1; D 1 point + poison, victims save at +2; AL N.

25. Recreation Room

The large room is only dimly lit by guttering wall torches. Fluttering shadows lie across wooden contraption of inhuman torture. A sign is scrawled across the length of the western wall; it says "Recreation Room." There are doors in the north end of the east wall and the east end of the south wall. A large gate of iron bars stand closed in the center of the east wall.

The iron gate is locked with a key which is in the possession of the jailer in the room beyond the gate. Those who approach the gate will get his attention and he will start yelling for help. There is a trapdoor in the ceiling that leads to the Warehouse (Chapter 9: Oasis of the White Palm, Sandvoyagers Compound area 8a).

26. Prison

A 20-foot by 30-foot central area is flanked by locked cells with iron bar gates. A stumpy figure crouches behind a desk in the middle of the room, taunting and calling for help.

The bugbear jailer will make no move to attack the party, being content to simply make a lot of noise from behind his heavy wooden desk until help arrives. When the jailer calls for help, if Kalitrates has not been killed, he will appear 1d4 rounds later from the Guard's Hall (area 23). The two slavers, Abu Karesan and Kaedros, will appear in 1-2 rounds from their Quarters (area 27).

The bugbear holds the keys to the door and the cells. Only cell 26a is occupied.

Bugbear Jailer: AC 5; MV 9"; HD 3+1; hp 13; #AT 1; D 2d4; AL CE.

26a. Cell of Granicus

In a 10-foot square cell, a haggard figure lies slumped on the ground.

Tolnus Granicus, the old Guildmaster, has been a prisoner here for some time. Although abused and tortured, Tolnus has told the slaves nothing. He will be reluctant to trust the party at first but eventually will be won over to their cause. He knows:

The slavers took over the Guildhouse a few months ago and have been using it as a base for shipping slaves ever since.

Thurnas Netmaster made a deal with the Dervish cultists to kidnap Princess Shadalah, but the girl disappeared before the slavers could get their hands on her. The cultists apparently wanted her because she supposedly had some power over an efreeth they worship.

Tolnus thinks he knows where the princess is being kept. The efreeth has been raising an army of restless spirits, and Tolnus believes that they have the girl in their custody. For some reason, she is a threat to them. If they have her, they have taken her to that dreaded place of evil, the Crypt of Badr Al-Mosak.

Tolnus Granicus, Former Guildmaster: AC 10; MV 12"; F 3; hp 18; #AT 1; D Unarmed; AL LG.

27. Quarters

Wall torches illuminate the 20-foot square room. Bunks line the walls and a table stands in the middle of the room. Two dark-robed figures look up suddenly at your approach.

The figures in the room are Abu Karesan, a fighter, and Kaedros, a magic user. They are part of the slaver band. In a chest under the southern bunk can be found 1200 ep, 2200 gp, and 150 pp.

Abu Karesan: AC 5; MV 12"; F 2; hp 9; #AT 1; D 1d8; AL NE.

Kaedros: AC 10; MV 12"; MU 5; hp 11; #AT 1; D 1d4; AL LE. He has a *potion of gaseous form* and a *wand of paralyzation* with 11 charges. He carries the following spells: *sleep*, *charm person*, *magic missile*, *shield*, *invisibility*, *stinking cloud*, *slow*.

Chapter 11: Crypt of Badr Al-Mosak

Background

The Crypt of Badr Al-Mosak is the current stronghold of the Efrete Pasha Khalitharius. Here, he has gathered his minions to wage a spiteful war against all the living. After capturing Princess Shadalah in the Oasis of the White Palm, he brought her here and made her captive in a bottle.

The Legend

Khalitharius has brought the princess here because he knows she is important to his safety, though he is not yet sure why. He feels that she is somehow tied to Martek, perhaps sensing Martek's magic from the mark on her palm, which that magic created. He feels that as long as she is his prisoner, she cannot harm him. Because he does not know the exact role she plays, he has not killed her. He senses that if she dies, another will take her place, someone who may not be so easy to find and capture. Thus, he keeps her here, imprisoned in a bottle.

What Khalitharius does not know is that the princess holds the key to his doom literally in the palm of her hand. Martek foresaw the need to involve the hereditary Sheik controlling the Oasis of the White Palm in his plans to banish Khalitharius forever. Knowing that unless the steps necessary for such banishment were kept alive in legend they would be lost to antiquity, he caused a magical medallion to become the symbol of the Sheik's office and the palm mark to be magically transferred to the palm of the Sheik's first wife. Legend tied the two together.

As part of his preparations for the events that are occurring now, Martek persuaded the Djinn Vizier Aeraldoth that he must eventually fight Aeraldoth to allow himself to be imprisoned in the city of Phoenix, not far from the Oasis of the White Palm. Now, when the palm mark on the princess' hand is matched up with the Medallion of the Sheik, a map to the djinn's location and the method of freeing him will be revealed.

Furthermore, the Crypt contains another of the Star Gems Martek had given to the rulers of the area. This one is the highly-prized and jealously guarded (even in death) booty of Badr Al-Mosak, an evil ruler who stole the gem from its rightful owner many years ago. The theft and the location of the gem are part of the local legend, as is the deadly and evil nature of the crypt. Now the gem awaits the party. They will need it to gain access to Martek's tomb.

Expected Play

It is expected that the PCs will travel here in search of the princess, and most likely they will come face to face here with the efrete. If they have the medallion from the Sheik, they will be

able to drive off the efrete and, by putting it together with the mark on the palm of the princess, find out how to release the djinn imprisoned by Martek.

To reach Khalitharius and the princess, the PCs will have to descend the shaft from the Amphitheater (area 1). After passing through the Lower Level, they must use one of the Pits of Everfall (area 12) to climb to the Crypt Upper Level. There they will find their goal.

The clues to adventure beyond this point are provided in the diagrams of Hassan's medallion and his betrothed's palm mark. These may be photocopied and used as game aids, as described in *Bride's Keep* (Crypt Upper Level area 2).

Random Encounters

The DM should check for a random encounter once every three game turns. A roll of 1 on 1d6 indicates that an encounter takes place. If an encounter occurs, roll 1d12 and use the corresponding encounter number from the Crypt Random Encounter Table below.

Crypt Random Encounter Table

- 1-4. 1-2 Mummies: AC3; MV 6"; HD 6+3; #AT 1; D 1d12 + disease; AL LE; SA Fear; SD +1 or better weapon needed to hit, takes half damage from all weapons.
5. 2d4 Wights: AC 5; MV 12"; HD 4+3; #AT 1; D 1d4 + drain one level; AL LE; SD silver or magical weapon needed to hit.
6. 1d8 Wraiths: AC 4; MV 12"/24"; HD 5+3; #AT 1; D 1d6 + drain one level; AL LE; SD silver or magical weapon needed to hit.
7. Spectre: AC 2; MV 15"/30"; HD 7+3; #AT 1; D 1d8 + drain two levels; AL LE; SD +1 or better weapon needed to hit.
8. 3d6 Giant Rats: AC 7; MV 12"/6"; HD 1-4; #AT 1; D 1-3; AL N; SA 5% chances of disease per bite.
9. Gorgon: AC 2; MV 12"; HD 8; #AT1; D 2d6; AL N; SA breath turns flesh to stone.
10. 1d4 Giant Cobras: AC 5; MV 15"; HD 4+2; #AT 1; D 1-3 + poison; AL N.
- 11-12. 1d4 Giant Spiders: AC 4; MV 3"/12"; HD 4+4; #AT 1; D 2d4 + poison; AL CE.

Crypt Entrance Encounter Areas

For play in this area use the cross-section view provided in the *Map Booklet*.

1. The Amphitheater

At close range, it is possible to tell that the statue is not the towering menace that it appeared to be from the distance. Instead, it is only 10 feet tall, of one piece with the 3-foot-tall base on which it stands.

Though much smaller than it once appeared, it is no less menacing. Fear flows and ebbs from its surface like the waves of the rising tide. Each new wave breaks upon the mind, sending chills up the spine, bringing a cold sweat to the brow, and releasing a rivulet of terror from the underarms. The stomach quakes, and the feet have a nearly uncontrollable desire to flee.

A thing of nightmares, this statue glares from beneath a pharaoh's headdress. Robes gathered in one arm, it clenches a scepter in the other. Neither time nor weather has dared deface the almost perfectly smooth surface of the midnight blue stone. The feet of the statue pass seamlessly into the broad curve of the base, which, miraculously, is free of dust or sand. The scalloped edge of the base makes an ominous contrast to the dead-white marble platform atop which the statue stands. The platform has three broad steps above the floor of the amphitheater. Arrayed around it are the seats of the amphitheater, 10 in all rising to the level of the broken pillars.

The statue emanates a permanent *fear* spell at -2 on the saving throw. It has been placed on the statue by Khalitharius to keep normal beings away. It has no effect on any of his minions.

The statue and the stone on which it stands weigh only 800 pounds. The base covers the entrance to the Shaft into the crypt (area 2). The statue's fear effect will be permanently negated if the statue is moved.

2. Shaft

The shaft revealed beneath the statue drops into darkness. It is 10 feet in diameter.

The shaft runs 90 feet straight down and then suddenly opens into the Cold Welcome (area 3). Any object larger than 3 cubic feet that passes the shaft's 80-foot level will trigger a timing mechanism. About 1 round after that point is passed, a scything blade cuts across the full width of the shaft, cutting anything in its way. Any character at the 80-foot level of the shaft must make a Dexterity check or be hit by the blade for 2d10 damage points.

A trap built to discourage grave robbers, the trap is not meant to kill outright. Razor sharp, the blade is instead meant to sever ropes, sending anyone on them into the pit far below.

Thus, any rope that extends below the blade when it makes its pass will be cut cleanly at the 80-foot level. A falling character may make a Dexterity check at -4 to catch the edge of the Lower Level as he falls past. If he fails, he will take 8d6 as he falls to the floor of the natural cavern 120 feet below.

The trap will activate whenever the 80-foot mark is passed. It can be broken by giving it 10 damage points. It makes the journey only once for each activation, and ignores anything that crosses the 80-foot mark between being activated and making the pass. In the one round between activation and making its pass, it is just barely possible to make it down the rope and onto the platform of the Crypt Lower Level. A successful Dexterity check will allow this to happen. A second character may try at a penalty of -4. The blade will break after taking 10 points of damage.

Crypt Lower Level Encounter Areas

For play in this area use the Crypt Lower Level map in the *Map Booklet* and appropriate inscriptions from the reverse of the DM's fold-up map.

3. Cold Welcome

The 10-foot-wide shaft cuts through the center of a huge 30-foot-diameter domed chamber. The shaft continues through the chamber floor and opens into a deep natural cavern below. Four arched corridors situated at the compass points lead off into the darkness.

See the accompanying cross-section view of the Crypt Entrance for clarity. The cavern below the chamber is 90 feet deep.

3a. Prickly Part

At the end of the 10-foot-wide by 20-foot-long arched hall to the south is a statue, its features obscured by the 2-foot-long shining blades that stud its body. The blades point back down the corridor toward the shaft.

The statue is actually a hinged door to the Outer Temple (area 4). The door handle is somewhat hidden by the blades, but can be seen clearly by anyone within five feet.

3b. Blade Dance

At the end of the 10-foot-wide by 20-foot-long arched hall to the west is a statue of a woman with six arms and the head of a fish. The statue spans the entire corridor. In each

hand is a gleaming sword with something dripping from it.

There is a pressure plate 10 feet down the corridor toward the statue. Any weight over 10 pounds on the platform will cause the statue to animate. It will swing its blades (THAC0 15) and rush down the corridor (MV 18"). 1d6 of its blades get a swing, causing 4d6 damage points if they hit and forcing the victim out of the corridor toward the shaft. A Dexterity check at -2 will allow the stricken PC to roll out of the way. After its rushing attack, the statue will take one turn to retract to its original position.

3c. Fire Dance

The 10-foot-wide corridor to the north is 20 feet long. At the end stands a statue of an efreet, its arms folded and its eyes hooded, and its mouth opened.

There is a pressure plate 10 feet down the corridor, and any weight in excess of 10 pounds on it causes a magical trap to activate. A *fireball* will issue from the statue's mouth, filling the corridor, the domed chamber, the side corridors, the upper shaft, and the lower cavern to a depth of 20 feet. The fireball has a damage potential of 6d6, and everyone within the area will take damage.

3d. Bow for Arrow

At the far end of the east corridor, which is 10 feet wide and 20 feet long, a statue stands carved into the back wall. Each of its four arms hold silver bows with arrows at the ready.

There is a pressure plate 10 feet into the corridor, and any weight in excess of 10 pounds on it will cause the four bows to release one silver arrow each. Everyone in the corridor must make a Dexterity check to avoid being hit. Those who fail suffer 1d6 damage points. After striking, the arrows disappear, only to magically reappear in the bows of the statue. If a PC passes the pressure plate, he may remove the arrows.

4. Main Outer Temple

The door opens to reveal a 30-foot-square room the walls of which are covered with ornate runes. Against the center of the south wall there stands a large statue of a man with his arms folded across his chest. A crook is in one hand; a flail is in the other. There are doors at the far south ends of both the east and west walls.

A trail of 80 platinum pieces runs from the center of the room up to the base of the statue.

5. Office of Evil

Five hunched figures move in the shadows of this 20-foot-square room.

Five wights are here waiting for the next chance to enter the tomb. In their midst is a small pile of booty that they have collected: a *dagger +2*, a *scroll of protection from elementals*, and two *potions of invisibility*. There is also a scroll of three 4th-level MU spells, written at the eighth level of spell use; the exact spells are chosen by the DM.

Wights: AC 5; MV 12"; HD 4+3; hp 16,20,16,18,23; #AT 1; D 1d4 + drain one level; AL LE; SD silver or magical weapon needed to hit.

6. Office of Rest

This plain room is 20 feet square. Its walls are smooth marble panels.

There is a secret door in the southern half of the east wall. It opens onto a long roughhewn corridor that goes 10 feet east before turning south. The corridor runs 120 feet to the south and ends in a secret door to the Oracle (area 9).

7. Catacomb of Kings

Behind the concealed door, is a long, 10-foot-wide bridge stretching toward the south across a deep chasm. The walls of this room, 20 feet away on either side of the bridge, extend 30 feet above the bridge and drop into unyielding darkness below. They parallel the bridge as far as can be seen. Long, heavy strands of moss and mold dangle down from the sides of the bridge, dripping into the darkness below. The chill of death is in the air and soft moaning cries swell up from the void beneath the bridge.

The bridge is 110 feet long. Sixty feet below it are the mass tombs of the crypt. The minions of the efreet, called the Malatath, rest on the floor of the tomb below.

Each character attempting to cross this bridge must make a Dexterity check or make enough noise to draw the attention of the Malatath. If their attention is drawn, each group will appear in the order listed below, the first immediately, the others at 3-round intervals. The undead that cannot fly will climb the moss strands, appearing at random along the bridge. Clerics may attempt to turn each group separately.

1d4 Mummies: AC 3; MV 6"; HD 6+3; #AT 1; D 1d12 + disease; AL LE; SA Fear; SD +1 or better weapon needed to hit, takes half damage from all weapons.

2d4 Wights: AC 5; MV 12"; HD 4+3; #AT 1; D 1d4 + drain one level; AL LE; SD silver or magical weapon needed to hit.

1 Spectre: AC 2; MV 15"/30"; HD 7-3; #AT 1; D 1d8 + drain two levels; AL LE; SD +1 or better weapon needed to hit.

1d4 Wraiths: AC 4; MV 12"/24"; HD 5+3; #AT 1; D 1d6 + drain one level; AL LE; SD silver or magical weapon needed to hit.

1d8 Shadows: AC 7; MV 12"; HD 3+3; #AT 1; D 1d4+1 + drain one strength point; AL CE; SD +1 or better weapon needed to hit.

8. Altar

A shaft of light pierces the darkness from the domed ceiling above, illuminating an altar in the center of a 50-foot-diameter room. The walls are covered with five different inscriptions. The altar seems to be made of clear glass. Carved doors stand closed at each compass point.

The inscriptions, written in the ancient alphabet, are reproduced as Inscriptions 11A-11E on the reverse of the DM's fold-up map; they are translated as follows:

11A. May Seker grant thee welcome to his place of rest and worship. May he aid you in your kindness and grant unto you the powers that you deserve.

11B. Mighty Seker, God of Light, purifier of the unclean souls that have lost their way to heavenly rest, is honored here.

11C. If thou believest in his might and glory, thy sacrifice at his altar shall gain thee a boon.

11D. Seker shall shine forth in the last days, when all the world despairs, to assist in the destruction of the great evil that spreads across our land.

11E. His might shall sunder the restless spirits and put an end to their sinful evils.

Magical items brought within three feet of the altar will cause it to glow and hum softly. Anyone holding a magical item within that three-foot range will receive the thought "Seker asks." If anyone places a magical weapon,

rod, wand, or staff on the altar, the item will suddenly flash with blinding light and disappear. One round later a second flash will occur on the altar and the *Harness of Seker* will appear, and the altar will not again react to magic.

The *Harness of Seker* is a powerful gift from the god Seker, granted in times of great need. It is shaped like a glove with holes for fingers and a harness that extends down the wrist and forearm. The *Harness* is of NG alignment and is usable by good-aligned clerics only to destroy undead; anyone not of good alignment will take 1d4 damage points per round that it is worn.

The *Harness* vibrates whenever undead creatures are near. If the cleric wearing it extends his arm, the *Harness* will detect all undead within 30 feet of him in the direction his arm is pointed. The *Harness* is capable of discharging a 30-foot-long bolt that will do 40 damage points to any undead creature; all the cleric wearing it must do to discharge his bolt is to point his arm at the undead creature within sight and range and say the word *Seker*.

The *Harness* is a charged magical item with respect to the bolts. Each bolt uses one charge of the 5 maximum the *Harness* can hold. The device gains its charges through the sacrifice of a magical item on the altar consecrated to Seker. If a magical weapon is sacrificed, the device will have a number of charges equal to the highest "plus" of the weapon; thus if it were a sword +1, +2 vs. dragons, the *Harness* would have 2 charges. If a rod, wand, or staff, is sacrificed, the *Harness* will have a number of charges equal to the charges of the sacrifice, to a maximum of five.

When the final charge is expended, the magical weapon or item sacrificed will reappear in the hand of the person who sacrificed the item. The item will be in the same condition as when it was offered. When the sacrifice is returned, the *Harness* disappears. No one can receive the *Harness of Seker* more than once.

9. Oracle

In the center of a 30-foot-octagonal room, an eight-foot tall obelisk of black stones stands. Small and detailed engraving is etched into the base of the obelisk. Two archways exit the room at the front and back while two facing alcoves stand to either side.

If a question is asked in the room, a wise, old voice will answer as an oracle would. To determine the answer given, roll 1d10 and consult the table below. An answer may be given more than once. It may take the players some time to figure this time-waster out.

Answers from the Oracle

1. Indications are not good at this time.
2. Do not suppose too much, nor take unseen things for granted.
3. It could be to your better interests.
4. Dark things are on the horizon.
5. Things are not as they seem.
6. It must be soon.
7. Another tactic might prove wiser.
8. Extreme caution must be applied.
9. Your perseverance will be rewarded.
10. Despair if you continue thus.

10. East Priesthood Room

In the center of this 30-foot-square room stands a 10-foot cube. The flat ceiling is only 10 feet above the top of the cube.

The cube is hollow and without a top; within are 4 necrophidi guarding a *Libram Of Gainful Conjuration*. Players may gain access to the cube's interior by climbing over its walls. There they will be greeted by what appear to be the skeletons of giant snakes with fanged human skulls for heads. They are not undead and cannot be turned by a cleric. The *Harness of Seker* will not function against them.

Necrophidi: AC 2; MV 9"; HD 2; hp 12,9,8,7; #AT 1; D 1d8 + paralysis; AL N; SA swaying movements have hypnotic effect; bite paralyzes for 1d4 turns, save applicable.

11. West Priesthood Room

In the center of this 30-foot-square room stands a 10-foot cube. The flat ceiling is only 10 feet above the top of the cube.

The cube is hollow and without a top. Players may climb over the walls of the cube to gain access to its interior. This cube is empty.

12. Pits of Everfall

The hallway suddenly ends, opening into a 30-foot-diameter vertical shaft that appears to extend both above and below, beyond the limits of sight. Small rocks and debris fall from above and pass down the shaft. Wind howls down the shaft into the darkness below.

There are three of these shafts, identical in function but differing small respects as described below. Each is a shaft that extends 140 feet above and 50 feet below the opening on the Crypt Lower Level. Fifty feet above that opening, there is an opening that leads to the Crypt Upper Level; the PCs must use one of these shafts to attain that level.

In the Pits of Everfall, nothing hits bottom, because everything that reaches the bottom is instantly teleported back to the top of the shaft (see the accompanying diagram). Thus, everything seems to fall in endless cycles. Ropes over 200 feet long lowered into the pit will appear dangling overhead.

If a party member should fall down the shaft, his companions will see him fall past them again and again. If a falling character is stopped abruptly, he will take 20d6 damage pts. If he is gently stopped somehow, then no damage will be suffered. Each round that a character is in the shaft, he must make a Dexterity check to avoid being struck by the objects already in the shaft. A character under *levitate* or *feather fall* has a bonus of -2 to the roll. A flying character will automatically avoid being hit.

Within the Western Everfall (area 12a), a skeleton in broken plate mail accompanies the small rock debris.

Within the Southern Everfall, treasure falls in an endless loop. Occasionally, a crystal ball, a gleaming helmet and shield, a scroll, and two small bottles may be seen. These objects are a *crystal ball (clairaudience)*, a *helm of alignment change*, a scroll of *fireball* written at the sixth level of magic use, and two vials of *oil of slipperiness*.

Within the Eastern Everfall fall three mummies. Woe to anyone hit by a flying mummy!

Mummies: AC 3; MV 6"; HD 6+3; hp 25,24,18; #AT 1; D 1d12 + disease; AL LE; SA fear; SD = 1 or better weapon needed to hit; half damage from all weapons.

Crypt Upper Level Encounter Areas

For play in this area, use Map 11-3 in the *Map Booklet* and the appropriate inscriptions on the reverse of the DM's fold-up map.

1. Light Web

The climbing stairway opens into an area of a thousand beams of light, endlessly reflected off crystalline walls. It is impossible to determine the shape and extend of this room for the glare, which prevents clear sight more than one foot into the area, the quarter-inch wide beams obscuring vision.

One of these rooms will greet the PCs no matter which of the Pits of Everfall (Crypt Lower Level area 12) they ascended. The function of these rooms is identical, with only the locations of the four damaging beams varying. Use the accompanying oblique view and cross section diagram to determine their location on the map, and then adjust the compass directions according to the particular room in which the PCs find themselves.

Beam A runs two feet above the floor. It strikes as a 10th-level *cone of cold*, doing 1d4 + 10 damage points to anyone it strikes.

Beam B runs six feet above the floor. It strikes as a 12th-level *disintegrate*, destroying any object that comes in contact with it. Characters must save vs. spells or disintegrate.

Beam C is four feet above the floor. It strikes as a 10th-level *lightning bolt*, causing 10d6 points of electrical damage to anyone touching it.

Beam D is three feet off the floor and acts as a 10th-level *teleport*. Anything contacting this beam will be instantly teleported into the Southern Everfall (Crypt Lower Level area 12b).

A *darkness* or *continual darkness* spell will block out all light, but it will not negate the effects of the 4 destructive beams. A *dispel magic* cast in the area could knock out any or all of the beams. For each beam, roll percentile dice as usual to determine the effectiveness of the *dispel*.

2. Bridal Keep

Stairs lead up to a vast room. The room is dark and an evil presence can be sensed here.

Within the room, the PCs will come face to face with Khalitharius, the evil Efreet Pasha to the Fire Sultan. He is holding a large crystal bottle closed by a stopper, which he will put down when he senses the PCs.

If the party has Hassan's amulet, it will glow as soon as they enter the room from the stairs. A cold blue ray from the amulet will strike the chest of Khalitharius, who will retreat in pain and fear, taking no other action. In the following round, Khalitharius will put down the bottle with extreme care, freeing his arm for spell casting. Then, in the next two rounds, he will cast *flame strike* at the person carrying the amulet, then *fireball* at the party. On the fourth round after the ray strikes, he will enter the Astral Plane.

If the party does not have the amulet, they will automatically gain initiative on the first round as Khalitharius sets down the bottle. The efreet will then fight until he has lost half or more of his hit points, at which time he will enter the Astral Plane.

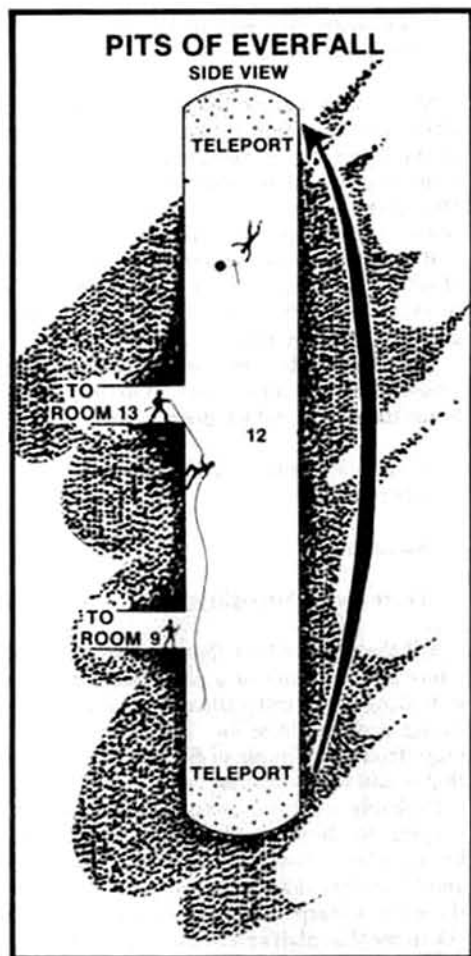

The heavy bottle contains Princess Shadallah, the betrothed of Hassan, eldest son of the Sheik of the Oasis. She cannot be seen within the bottle, but the bottle will radiate magic if *detect magic* is cast upon it. The stopper is marked with the symbol of an evil clerical order. If the stopper is removed, a pillar of soft blue gas will rise from the bottle and fall to the floor, becoming the princess.

Shadallah is graceful and slender. She is well read and knows the ancient legends of the tribe. Her knowledge, therefore, includes the following:

The impressions upon her hand and the amulets that were given to the sheiks of the nomadic tribes were granted in ancient times by the great Martek. They were to be used somehow to combat the great evil that Martek foresaw. Once, say the old writings, the meaning was passed from father to son, but somehow the message has been lost.

The efreet, just before imprisoning her in the bottle, arrogantly said that he once feared only one thing and that

now, with Shadalah in his power, the world was his to own.

Shadalah will show the PCs her palm mark if they ask. It has upon it a map to the location of the Djinn Vizier Aeraldoth, who is voluntarily imprisoned in the lost city of Phoenix. It also gives instructions on how to find and release him to fight Khalitharius.

If the players say that their characters place Hassan's amulet against Shadalah's palm mark, there are two ways for the play to proceed, as described below.

The easiest, but probably the least fun, would be to read the inscription to the players. It has three lines, which plainly say:

City of Phoenix over the House of Set
where sleeps

Salvation

There speak Atmophryeetno

Tell the players that there is also the word *white* and a picture of a palm tree, an arrow indicating south and a triangle, probably indicating a desert location. Then, on Martek's map (from the Temple of Set), indicate where that is and let the players take it from there.

Probably more fun would be to allow the players to discover the secret themselves. Before play, photocopy the diagram of the amulet and the diagram of the palm sign; have these and a sharp hobby knife ready. If the PCs ask to see Shadalah's palm mark, give the players the diagram of this mark. If they say they are comparing it to the amulet, give the players the diagram of the amulet, indicating which portions of the amulet are cut-outs. These pieces of art will provide the players with their next clues. Should the players cut out the appropriate places on the amulet diagram and then place it on top of the palm mark diagram, they may read the message from Martek and see the location of the lost city of Phoenix. If the players lay the diagrams on top of Martek's map (from the Temple of Set) with the palm tree symbol on top of the Oasis of the White Palm, the triangle will show them exactly where Phoenix is.

Khalitharius, Efreet Pasha to the Fire Sultan:
AC -3; MV 24"/24"; hp 101; #AT 2; D 2d10/2d10; AL N; SA see below; SD see below; MR 40%. He can use any of the following, at will, as a 15th-level MU: *fireball*, *flame strike*, *detect magic*, *enlarge*, *invisibility*, *assume gaseous form*, *wall of fire*, *polymorph self*, *create illusion* with both visual and aural effects; *fulfill another's wish* (although loath to do so). The Pasha is immune to all fire attacks. He can travel among the planes known to the efreets.

Princess Shadalah: AC 10; MV 12"; F5; hp 26;
#AT 1; D 1d4; AL NG.

3. Treasure

A dark staircase descends to a 50-foot-square room. In the center of the room stands a single pillar bathed in a column of light. Glistening atop that pillar is a huge cut jewel, its facets flashing with a fiery light. The floor is paved with hexagonal flagstones of marble, each 5 feet across. A single arched portal is in the center of the opposite wall.

The red gem is a huge ruby, the Star of Shah-Pelar, the Star Gem that Martek once gave to a desert pharaoh. Long ago, it was stolen by Badr Al-Mosak, becoming his favorite treasure. It is protected from theft by several traps, each of which must be overcome if the PCs are to leave the room alive with the gem.

The floor is a mixture of real flagstones and illusions of real flagstones that hide acid pits 4 feet deep. The PCs will have to safely negotiate

the trap to get to the pillar and the portal beyond. A character who steps into an acid pit will take 2d4 damage points each round he remains there. The inset on the map shows which hexagons are real and which are illusions. A good way to play this out is to make a map using 1-inch-hexes and require the players to move figures over the map, one hex at a time. Smaller hexpaper may also be used, with players showing their movement by drawing on it with pencils.

The beams of light reflecting from the facets of the Star Gem will inflict 3d10 damage points per round to everyone who comes in contact with them light. Before the gem is moved, these beams may be seen as ruby rays that are produced as the light reflects from the gem. The rays are clearly seen as they penetrate the darkness. In playing this out, tell the players when their PC is about to cross one of these ruby rays. If they take no precautions, give them the damage. Any object can be used to block the rays and their effects. The gem will not be able to be taken from the pedestal without doing this, for the rays from the upper facets are very concentrated there.

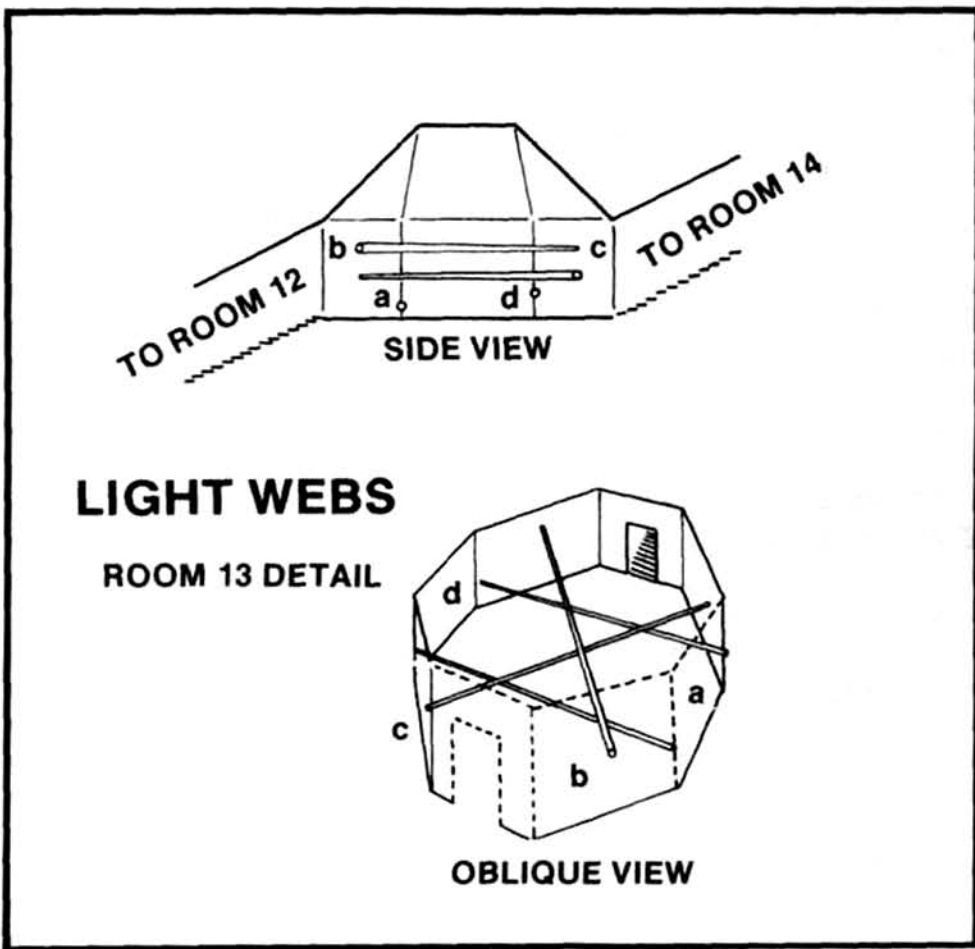

Removing the gem could set off the third trap. The gem weighs 5 gp. If it is removed without replacing its approximate weight on the pedestal, then beams of magical light will shine on each of the real flagstones, covering them entirely. Anyone passing through these beams of light must save vs. spells or be turned to stone. A new save is required for each new hex entered and crossed. Furthermore, if the gem has not been covered, the light will strike it, giving a 1 on 1d4 chance that anyone in the room will be struck by a random ray.

4. Vacant Tomb

The walls of this tomb are scorched, blasted, and pitted, as if a fierce battle took place here long ago. Rusted weapons, scraps of cloth, and other junk are scattered across the floor.

The tomb is otherwise empty.



Chapter 12: Lost City of Phoenix

Background

The City of Phoenix

Carthage, as the City of Phoenix was once called, was the playground for the Pharaohs of the fertile plain. Here they came when they needed rest and revival, so often doing so that the city became legendary in its ability to restore those who visited it. The wealthy and powerful who visited were "reborn" from the ashes of their past as the legendary phoenix rose from its ashes to live again. The city, renamed for the legendary bird, became a resort known for its healing waters and the revitalization it gave the spirit.

Those who operated the resort knew the secret, although much of that knowledge died with them as the fertile plain turned to desert. The city abounded in jokes, tricks, and puzzles that catered to the whims of the very rich. Mazes and other more dangerous traps were carefully watched so that no one would die in them, but their guardians have long since disappeared. Now the traps and illusions, the tricks and the pitfalls, the mazes and the puzzles remain, hidden beneath the desert sands.

As the sands encroached on the city, a huge magical dome was created from it to protect the streets, buildings and gardens. The magic remained even after the citizens of Phoenix had gone, and eventually, the dome covered the entire city, save for the roofs and minarets of the tallest buildings. The dome, several feet thick and very strong, could support a man on his camel, and so the city's location became lost to the sands of the desert and the sands of time.

Occasionally, a luckless traveler would break through the dome, and drop to the street below. If he were alone, he would have little or no hope of rescue. If he were in a caravan, the others in his party would see his sinking into the sand as evidence of the dangerous shifting sands and sinkholes for which the Desert of Desolation is well-known. They would then bypass the area as one of great danger.

So the city still sleeps, parts of which are yet untouched by the outside world.

The Imprisoned Djinn

One thousand years ago, when Martek foresaw that Khalitharius, the evil Efreeth Pasha he had imprisoned in the garden city of Pazar, would escape, he was in a quandary. He clearly did not want Khalitharius to escape again, and he knew that if the efreeth were to do so, anyone alive in the desert would suffer.

Finally he hit upon a plan. He teleported himself to the Grand Hall of the Caliph of the Djinn and secured an audience. Skilled in diplomacy, he played upon the djinni's longstanding hatred of the efreeth. Long and poetically did he speak, recounting his terrible battle with Khalitharius, rejoicing in the

efreeth's imprisonment, sorrowful at the shortness (in djinni terms, at least) of his confinement.

At long last, nearly exhausted from his performance, for such it was, Martek was able to raise to the breaking point the ire of Aeraldoth, one of the six Viziers to the Caliph. Sighing with relief at Aeraldoth's shouted question, he admitted that there was one thing he could do. Martek described a band of adventurers whom he foresaw would release the efreeth. He then told of the efreeth's surprise when, momentarily later, they released a powerful djinn, who would rise to combat him.

Martek told the Caliph and his advisors that he had the magical might to summon a djinn and command him to await this occurrence. But, he said, this would never do, for the djinn he would be able to imprison against his will would likely be no match for the wily and exceedingly powerful Efreeth Pasha Khalitharius. Quietly he reflected that he had no solution, and begged the Caliph to advise him.

No sooner had he made his request than Aeraldoth demanded of his lord that he be given the chance to confront Khalitharius, with whom he had had previous encounters. He volunteered to be imprisoned by Martek to await the puny human adventurers whom he was to help. Smiling to himself at his success, Martek agreed, sealing the bargain with a grand present to the Caliph.

Thus it came to pass that Aeraldoth lies here, waiting to be released. And thus it will occur, when the PCs discover his prison and release him, that fearsome battle will be joined, the which will rage over the desert near and far.

Expected Play

This is the Lost City of Phoenix, hidden for 1000 years by the shifting sands of the desert. There is no escape from the city that can be accomplished by normal means. Magical attacks against the dome of sand will be repelled, and *levitation* or *fly* spells that will allow a party member to approach the dome will not allow the member enough time to cut through the sand. Any cut made in the underside of the dome will first release flying sand and dust the will blind (30% of the time) the adventurer or fill his nose and mouth with sand (15%).

The players will have to negotiate the length of the street, crossing through the buildings where the street is blocked by fallen sand. Once they have reached the center section, they will be able to release the Djinn who is imprisoned in the stone shrine. There are numerous traps/tricks with which the party must deal on their journey; some of the tricks/traps cause no damage, while others can be quite deadly.

Lands of Carthage Encounter Areas

Random Encounters in the Lands of Carthage

For night travel (day travel has its own problems) within 15 miles of Phoenix, use the Carthage Area Random Encounter Table below. Roll 1d6 every six turns to see if an encounter takes place; on a roll of 1, roll 1d12 and add appropriate modifiers to see which encounter occurs. For encounters within 20 miles but farther than 1 mile, there is no modifier. For encounters closer than one mile but farther than half a mile, add a modifier of +2 to the roll. For encounters between one-quarter mile and one-half mile, add a modifier of +5. For encounters closer than one-quarter mile, add a modifier of +8.

Carthage Area Random Encounter Table

1. Androsphinx: AC -2; MV 18"/30"; HD 12; hp 67; #AT 2; D 2d6/2d6; AL CG. This Androsphinx is moving across the desert to his home in the north. He is not aggressive in any way, but will take the opportunity of meeting the party to try out the famous riddle, "What walks on four legs in the morning, two legs at noon, and three legs at night?" If the party gives the correct answer, "Man" (crawls on all fours as a baby, walks erect as an adult, and uses a cane as an old person), the sphinx will point out the most direct (not the safest) way to Phoenix or any other destination the party has in mind. He will also answer three questions about the desert as truthfully as he can. If the correct answer to his riddle is not given, he will attack the nearest party member for three rounds and then fly away.
2. Purple Worm: AC 6; MV 9"; HD 15; hp 54; #AT 2; D 2d12/1d4 + poison; AL N; SA Swallows victim. The ground beneath the party begins to shake, and suddenly, from under the sand, the purple worm emerges.
3. Giant Roc: AC 4; MV 3"/30"; HD 18; hp 84; #AT 2 or 1; D 3d6/3d6/ or 4d6; AL N. The roc's shadow, cast by the rising moon, sweeps over the party. The roc is hunting over the desert at night, in search of animals that use the darkness as cover. It will not attack the party unless the party attacks by it. It will, however, seize and carry off one of the party's draft animals, if there is one. Generate randomly which animal is attacked.
4. Krite: AC 5; MV 15"; HD 4 +2; hp 14; #AT 1; D Nil; SA poison 4d6; AL N. This small (12-18"), brown snake is very deadly. It hunts the desert at night, seeking small

rodents, birds, and spiders as its prey. When encountered, as soon as a large creature approaches, the snake will roll into a ball in an attempt to look like a rock. If it is picked up, it will wait until it has a chance to strike against exposed flesh. Then, it will strike and attempt to escape before retaliation. The krite will not attack a man-sized animal unless it is bothered or attacked first.

5. 2d12 Centipedes: AC 9; MV 15"; HD 1/4; hp 3; #AT 1; D Nil; SA poison; AL N. The small, desert creatures are roaming the sands in search of carrion or small animals that they can kill for food. They will attack the party at once and fight to the death, having little intelligence.
6. Huge Trap-Door Spider: AC 6; MV 18"; HD 2+2; hp 14; #AT 1; D 1d6; SA victim must save vs. poison; AL N. This spider builds its nests in the shifting sands of the desert. It can leap 3" to attack its victim or lie in wait for its victim to fall through the roof of its lair.
7. 2d6 Hyenas: AC 7; MV 12"; HD 3; hp 15; #AT 1; D 2d4; AL N. These animals are traveling across the desert in search of a new home. They have been on the march for many days and are in need of food. They will attack any party member or draft animal they find alone or in a small group (maximum of 3 creatures or party members). They will not approach a fire. They will howl in an attempt to stampede draft animals that are not well secured.
8. 1d6 Jackals: AC 7; MV 12"; HD 1/2; hp 1d4; #AT 1; D 1d2; AL N. The jackals of the desert are neither strong nor brave, but they will attack any single member of the party or single draft animal if either strays from the party during the night. Once encountered, they will stalk the party from the first encounter each night until daylight, being driven off only by hyenas.
9. 4d10 Ants: AC 8; MV 12"; HD 1/4; hp 1-2; #AT 1; D 1d4; SA 30% have poison sting for 1d4 additional damage; AL N. These fire ants are in search of food. They may appear (30% + INT chance) to the party member in the lead as a dark, moving stain against the pale sand before they are actually encountered. The party may attempt to avoid them.
10. 3d6 Beetles: AC 5; MV 6"; HD 4; hp 1d4+10; #AT 1; D 2d4; AL N. First discerned by the faint clicking sound of their mandibles, these desert beetles are in search of food. If the PCs do not take steps to

investigate, the clicking sound will approach as the beetles come nearer. If not discovered by an advance scout, there is a 30% chance that they will discover the party itself by surprise. If they do, they will sense that here is all the food they will ever need, and attack at once.

- 11-12. Spectral Minion: AC 2; MV 30"; HD 3; hp 29; #AT 0; D nil; AL LG. Ahead of the party will appear a figure, colorless, nearly transparent, and still as death. The apparition, which is dressed in robes, will raise his arm, pointing to the city of Phoenix. Then it will begin to walk toward Phoenix, moving fast enough to keep pace with a walking man or camel. If it is approached closer than 10 yards, it will speed up to maintain its distance. The spectral minion will lead the party away from all danger during the encounter and will stay with the party for 3d4 x 10 minutes, during which there will be no other encounters.

13+. Sinkhole. See The Sinkhole and the Slide (Lands of Carthage area 3) below.

1. Phoenix from Afar

From a relatively high dune within 20 miles of the city, a shining light will be seen in the desert wasteland. This is the conical roof of one of the city administrative buildings. When the sands swept over the area, the roofs were the only part of the city that was not buried. Now they stand like a beacon to lure the unwary to their deaths.

Phoenix lies in a bowl-shaped area surrounded by soft sand and rugged mountains. Because of the mountains, the winds seldom blow and the heat is extreme. Daytime temperatures reach 150 to 180 degrees, bringing new dangers to the already dangerous desert. Water consumption by travelers will double within 20 miles of Phoenix, and double again within 10 miles. Daytime travel will be perilous as travelers risk heatstroke, dehydration, and burns from the superheated sand. It will be clear to all that only the best-prepared party will be able to accomplish the trek.

The most reasonable alternative is to shed as much unnecessary gear as possible and to travel at night. Even then, however, the temperature will not fall below 100 degrees and the sand will be almost painful to walk upon.

Mounts will be very reluctant to enter the area during the day; on response rolls for the mounts, add +4 to the 1d12 roll when between 10 and 20 miles from Phoenix, and +6 when within 10 miles. Within a mile of the domed roof, mounts will not approach unless magically charmed at +4 to their saving throw. They will sense the change in the sand even before their riders.

2. Approach to Phoenix

As the city is approached, the toil becomes unbearable. The heat is nearly overpowering, and, with each step, the leg sinks into the soft sand to the mid-calf as though the sand were a bottomless quagmire. There is nothing to do but plod on, for if one stops, he begins to sink. The glittering dome of the building ahead is a beacon, but does it warn of treacherous ground nearby, or does it promise refuge?

Reasonable caution can make the journey less dangerous and fatiguing. Motionless people sink into the sand at the rate of one inch each round. The only way to remain on the top of the sand is to spread the weight over a wide area. Snow-shoe- or ski-like appendages on the feet will stop the sinking. A reed mat can be used for sitting or sleeping.

3. The Sinkhole and the Slide

This encounter can take place only if it is rolled as a random encounter when the party nears Phoenix. In fact, because of the modifiers, this encounter becomes a more of a likelihood the closer to the city the party gets. A party member chosen at random begins to sink into the sand, sinking faster and faster, as though into a sinkhole (see *Chapter 6: Desert of Desolation*, encounter area 6).

Party members may come to his aid, but if they approach within 10 feet, they also will begin to sink. If the party throws a rope, and a sinking PC catches it, it will take a combined strength of 16 + 1 for each 20 pounds carried to halt his plunge. He will disappear in 1d4 rounds.

Unlike normal sinkholes, this is not a death trap, but a way into the city ruins below. Any party members caught will be smothered in sand for a brief time, taking 1d6 damage points, and then break through into darkness. Relief will be brief, however, for the trapped PCs will begin to glissade down a glassy-smooth tunnel, gaining speed the while. After a careening ride through the darkness, as the tunnel swoops and falls to the ruins below, which gives another 1d6 damage points from abrasion, the trapped PCs will come to rest in a pile of sand deposited on the Streets of Phoenix (Phoenix Ruins area 1A-1D).

This encounter is likely to split the party. All will be re-united when they get closer to the dome, but the players will not know this. The Lost City of Phoenix map in the *Map Booklet* indicates four possible locations for the PCs to be dumped. This is to account for more than one sinkhole to be encountered randomly. Run any PCs who fall here separately, keeping track of the relative position of all parts of the party. It will be a test of party ingenuity to

rejoin all split-off groups, so be careful not to kill off the various groups through random encounters.

All torches will be snuffed out by the suffocating sand. In addition, any items held are likely to be dropped (30%) and temporarily lost. For further adventure in this area, continue with the map and descriptions for the Phoenix Ruins Encounter Areas.

4. The Fall to the Streets Below

As the party approaches the glittering domed roof of the administration building, a party member chosen at random begins to sink into the sand, sinking faster and faster. Party members that are within 20 feet or that come to his aid also begin to sink. No prior preparations are sufficient to prevent the sinking, and no actions taken by the party will halt it once it begins. The party is on its way into the Lost City of Phoenix.

Be careful in judging this fall. The object of the encounter is to get the party into the ruins below. Have the players make saving throws as appropriate, but ensure that all sink eventually, no matter how lucky the dice rolls. Magic spells, such as *feather fall* or *levitate* will slow down the fall, but make it apparent through description that the adventure lies below. Perhaps the PCs remaining above can see the ruins below momentarily before the magic acts to re-enclose the city.

The sinking party members will be dropped to the Streets of Phoenix (Phoenix Ruins area 1A-1D) below as a portion of the sand dome covering the city gives way. The adventurers will fall 60 feet onto the pavement, taking 1d8 damage points. In addition, the PCs must make a Dexterity check, adding the damage taken +2 as a penalty to the die roll. Those who fail to save will be unconscious for 1d6 hours or until dawn.

Phoenix Ruins Encounter Areas

For play in this area, use the three maps for The Lost City of Phoenix in the *Map Booklet*.

Phoenix Ruins Random Encounters

While in the city, the players may encounter some of the current residents. To determine if a random encounter takes place, roll 1d6 for every three turns the party is in the city. On a roll of 1, an encounter takes place. Roll 1d12 and consult the Phoenix Ruins Random Encounter Table below to determine what the encounter is.

Phoenix Ruins Random Encounter Table

1. Beholder: AC 0/2/7; MV 3"; HD see hp; sp

55; #AT 1; D 2d4; SA Magic; SD Anti-magic ray; MR Special; AL LE. The beholder recently arrived, searching for minions to serve the efreet Khalitharius. It has made any of the glassy tubes that the PCs may have discovered in The Sinkhole and the Slide (Lands of Carthage area 3). If the beholder is not encountered and destroyed before Aeraldoth is released, it will leave immediately and notify Khalitharius of the djinn's presence, and the first encounter between the efreet and the djinn will take place over Phoenix.

2. Rust Monster: AC 2; MV 18"; HD 5; hp 16; #AT 2; D Nil; SA corrodes metal; AL N. This monster has been trapped below without food (metal) for a year, hence its lowered hit points. It is ravenously hungry and will attack as soon as the party comes within range.

3. 3d12 Red Spiders: AC 8; MV 6"; HD 1/4; hp 1-2; #AT 1; D Nil; SA poison; AL N. The tiny red spiders are so small as to pass almost unnoticed until their presence is announced by a fierce itching that follows their bite. They are blood drinkers and are attracted to any warm-blooded animal. They crush easily, leaving a smear of blood to mark their passing.

4. 2d12 Desert Ticks: AC 5; MV 3"; HD 1/2; hp 1d6 + 2; #AT 1; D 1d4; SA Blood drain; AL N. Once encountered, the ticks will follow the party until it stops for rest. They will then infiltrate the party, attaching themselves to the sleeping party members. There is a 5% chance that the victim will contract a fatal disease.

5. 1d10 Fire Ants: AC 8; MV 12"; HD 1/4; hp 1-2; #AT 1; D 1d4; SA 30% have poison sting for 1d4 additional damage; AL N. These small ants live in the sands above the city but sometime become lost and fall to the lower level. They are always hungry, there being no way for them to escape, and so they will attack the party members at once.

6. 2d4 Carrion Beetles: AC 4; MV 12"; HD 1 + 2; hp 1d6 + 4; #AT 1; D 2d4; AL N. The fire beetles have made an extensive home in the sands surrounding Phoenix. They eat the carrion from the surrounding desert, but they are usually hungry. They will not attack unless the party becomes aggressive toward them.

7. Krite: AC 5; MV 15"; HD 4 + 2; hp 14; #AT 1; D Nil; SA poison 4d6; AL N. When approached, this small, deadly snake will curl into a ball. If picked up, it will wait for

a chance to strike exposed flesh, then attempt to escape before retaliation.

8-9. 1d4 Skeletons: AC 7; MV 12"; HD 1; hp 1d4 + 4; #AT 1; D 1d6; AL N. These are the remains of adventurers who cursed the gods that put them here and were in turn cursed to become wandering skeletons in Phoenix. There are only 13 of these monsters. Each skeleton may be destroyed only once although they may be encountered and evaded more than once. The skeletons may pass through walls and sand if driven away from the party by a cleric.

10-11. Cry of Aeraldoth. The air, usually oppressively hot, becomes suddenly cold, twisting and turning, and setting up tiny Dust Devils that rise 2 feet off the floor. The chill passes almost at once with the soft, deep-voiced cry of "Free me." This is the thought-voice of Aeraldoth, who has sensed the presence of the party and is calling to them.

12. Spectral Traveler. Ahead of the party will appear a figure as though it rose from the very ground. The apparition is dressed in the elegant court attire of a Pharaoh. He stands, staring at the party, his hands on his hips. As the party approaches, he will raise his arm and point to the center of the city and then begin to walk directly toward that goal, passing through walls if necessary. He will move fast enough to keep pace with a walking man, speeding up as necessary to remain 10 feet in front of the closest party member.

1. The Streets of Phoenix

As the party awakens from the fall, they will find themselves in the Lost City of Phoenix. Read the following description to them at this time.

On either side of this paved street stand buildings of white marble. Both ends of the street have been blocked with sand that rises out of sight above the buildings. Small mounds of sand lie in various places on the street, fed by trickles falling from above. Aside from the soft swoosh of the falling sand, there is no noise, and when that stops presently, there is no sound — nothing; absolute silence.

Adventure may continue in a normal fashion if the PCs end up in area 1A. Passage from one encounter area to another is easy to accomplish. The first PCs to enter the ruins.

From area 1B, the PCs will need to climb the house of Khalif Mubrek, making their way along the slippery roof to area 1A. The second group of PCs to enter the ruins will end up here. The buildings that flank 1B can be scaled,

but those routes turn out to be dead ends.

Area 1C will be entered by the third group of PCs to fall into the ruins. From area 1C, the PCs can spot only the corner of the Secret Maze of Kharan (area 8). They can clear this away to get to the roof of the maze, and thence to the street that runs between the Maze and house of Khalif Mubrek (areas 5-7). From this point, the play may continue north via the Maze, or south to the dead end of 1A via Khalif Mubrek's place. Climb along the roof of the Maze and then to roof of Chininsk Ambar's residence will lead the PCs to the dead end at 1D.

Area 1D will be entered by the fourth group of PCs to fall into the ruins. From area 1D, the PCs must climb the roof of Chininsk Ambar's residence and go south to the roof of the Maze of Kharan (area 8). Play can continue then from the street in front of the Maze, as detailed above for area 1C.

If more than four separate groups fall into the ruins, the DM must make up areas in which they will appear. These areas should involve climbing over roofs (or through buildings which the DM must design) and eventually hook up with the ruins described below.

2. Foyer of Khalif Mubrek

Pillars and a filigree of stone separate this area, which appears to be a foyer for the house beyond, from the street. The floor is a swirling mosaic of white and cream-colored tiles that form a convoluted pattern. The walls are dark brown, baked-enamel tiles. In the center of the opposite wall is a door-way large enough to allow one man to enter at a time. Above the door is a sentence engraved in runes that reform as you watch to read "My fun is your fun."

The area is empty. All the inscriptions in this area are enchanted to be readable by anyone, no matter what his native tongue.

3. Sitting Room of Khalif Mubrek

To pass through the door to the sitting room, each member of the party must stoop slightly to pass through the door. As he does so, a chocolate cream pie will strike him in the face, spattering topping and filling over the unlucky adventurer. No matter what he does to avoid the pie, it will materialize out of thin air to strike him. If he completely covers his face, the pie will be delayed until he has entered the room, whereupon it will materialize for its strike.

The sitting room is appointed with fine couches and chairs, embroidered in pastels and gold. The walls are frescoed in murals that depict a city with beautiful buildings descending to a large lake that is dotted with the triangular sails of the small boats that ply its surface. Within are two five-foot couches enlaid with gold. A small chair is heavily encrusted with seed pearls and enlaid with gold. The high, bronze back of a throne-like seat with large arms is inscribed with runes that reform to read, "Rule ye all who sit here."

Each of the couches is worth 150 gp; the gold inlay alone is worth 10 gp. The smaller chair is worth 180 gp; the seed pearls are worth 20 gp, and the inlay is worth another 20 gp. If any one sits in the bronze throne-like chair, it will collapse. The seat drops out and the arms fall inward. As the victim struggles to rise, the legs will spread outward and the back will hinge forward, squeezing the unwary into a most undignified position. No damage will result. When the victim is extricated, the chair will return to its original shape.

4. Dining Room of Khalif Mubrek

Through a wide, tall, bow-shaped arch is a dining room. This long room is covered by a 30-foot arched ceiling supported by ornately carved beams. Spaced at 10-foot-intervals down the center of the room hang ornate, brass, oil lamps, each one having 7 spouts into which wicks have been placed. The floor is totally covered with thick, wool rugs colored in fantastic designs. In the center of the room is a long, low table, just high enough to eat from if the diner is seated on the floor. Pillows surround it, indicating that it would seat perhaps 24 guests. On the right wall in the far corner is another bowed archway.

The overhead lamps will light as the first player enters. As each player thereafter enters the room, a gong will sound and a meal will appear on the table. The meals appear at random places around the table. The meal consists of steaming roast meat, fresh fruits, pita bread, three goblets of wine, and a decanter filled with wine.

In order to traverse the room, the PCs will have to remove shoes/boots/sandals or suffer attack by the wool rugs. If any PC has not removed his foot-wear, the threads of the rug will snag his toes, causing him to trip (must make a Dexterity check to avoid falling). At the same time, the rug will remove, gently but forcefully, the offending foot-wear. Even if the

player manages to save against the trip, he will have his shoes removed.

If any of the PCs sits at the table for the meal, the spirit of Khalif Mubrek will appear. He is a smiling, pudgy, little man, dressed in the finest silks and satins. His fingers are covered in an assortment of rings showing gold, pearls, emeralds, rubies, and diamonds. He will wave to the party and speak in pleasant sing-song, saying:

"Welcome my friends. I am Khalif Mubrak, and I hope you did not take offense at my little welcome. Now you are my guests at dinner. Please, let us toast your continued fortune while in this lovely city. In front of you are three goblets; one of gold and two of silver. All of them are full of fine beverage. Please raise your golden goblet and drink with me. Long life."

The golden goblets are actually dribble glasses. A thief will have one half of his normal chance to detect this trap by casual inspection; when asking the player to make this roll, do not tell him what it is for.

If a PC drinks along with the Khalif, most of the liquid will pour down his shirt front and into his lap. If the party finds this prank offensive, or if they do not drink, the Khalif and the meal will vanish. If they laugh at this harmless joke, they may continue their meal. The Khalif will vanish as the last mouthful is eaten and with him the setting for the meal, but each party member still seated will find one of the rings Khalif was wearing on the table in front of him. As each picks up his ring, he will hear in his mind the final toast: "Long Life." The rings are worth between 200 and 500 gp each.

5. Entry Hall of Khalif Mubrek

The small, entry-hall of the house is illuminated from the light streaming in through the door to the street. To the left is a door that leads to another room. Across the threshold of the door leading to the street is the body of a man.

The body lies on its left side, head toward the outside door. The left hand reaches for the door, the right clutches at its throat. The body has been desiccated by the heat. Any attempt to move the body or search it will cause it to crumble to mere dust. There are no bones left in the figure; it has become one of the skeletons in the Random Encounter Table. All the clothing will turn to dust. He has no weapons, and the coin purse has three lead coins.

6. Kitchen of Khalif Mubrek

Along the left wall of this large, lofty kitchen, are three, large ovens and a cooking surface with an iron grate across a hearth. The opposite wall is lined with cupboards, and the right wall has three water taps. On the opposite wall is a doorway over which are runes that reform themselves to state, "Go out this door."

There is nothing in the room except for the water taps which drip water, ever so slowly, into the basins below them. The cupboards have been stripped.

The three water taps are more practical jokes. The first tap operates normally, but when a man bends to drink from it or take water from it, the water will lessen until the flow stops; the flow will begin again as the adventurer withdraws. The water from the second tap will flow normally until a PC tries to drink or withdraw water from it. Then, the water will pour forth to spray the PC in the face. This water in the third tap can be drawn or drunk without difficulty, but it will turn the lips and tongue of the drinker black for 24 hours after each use.

7. The Hall of Khalif Mubrek

This long, narrow hall is designed to lead to the sleeping quarters of the house. In the center of the hall is an obelisk of black stone upon which is inscribed a raised hand, palm facing toward the kitchen door. The obelisk blocks the view of the opposite wall. Several bodies can be seen beyond the obelisk.

As the runes over the exit in area 6 warned, the adventurers should not enter this room, for danger lies within. If they should not venture beyond the black obelisk, they will have to combat an exact duplicate of themselves.

This room is a lock to keep those who have entered the sleeping quarters of the house in those rooms. The side of the obelisk opposite the kitchen door is a *mirror of opposition*. If any PC approaches, it will produce his duplicate as soon as his reflection may be seen. The duplicate will step from the *mirror* and fight to the death. It will be armed and armored exactly like the PC, but there will be no magic attached to any of the duplicate's equipment. It will have the same number of hp that the PC has at the time of the attack. The bodies seen beyond the obelisk are those of unwary adventurers who were killed by their duplicates; these bodies did not produce skeletons. One is of a dwarf with a pickaxe.

On the floor just in front of the *mirror of opposition*, there is a trap door. It leads to a cellar below. In the cellar is a rough-hewn tun-

nel that leads to the pit beneath the Death Trap of Chinisk Ambar (area 12); this tunnel was made by the dwarf with the pickaxe, who was unlucky enough to be killed by his duplicate, a classic case of tunneling from the frying pan into the fire.

8. The Secret Maze of Kharan

The door stands open to a darkened room beyond. Light supplied by torches and the glow from above has difficulty piercing the interior gloom. From the room comes the musty smell of stale air, as though from something long-dead. Above and around the door are inscribed runes, which reform themselves to read:

Step boldly all who enter here. 'Tis not the place for cowards.
Conquer selves and inner fear.
Who dares will be rewarded.

For play in this area, use Map 12-2 in the *Map Booklet*. The play of the maze is divided into two parts: the party must negotiate the Maze of Darkness to find the teleporter that will take them to the Maze of Light, where they must negotiate the Hall of Mirrors to find the exit.

8a. The Maze of Darkness

Just inside the door is a 4-foot-wide corridor that branches off to the right. The walls, floor, and ceiling are constructed of black stone, so dark and lusterless that they seem to absorb all light. The only sparks of color being the clothing and equipment.

The party should be allowed to grope through the maze, turning which ever way they want. Sooner or later they will reach the silver teleportation disk set into the floor of the maze. They will have to use this disk to enter the second portion of the maze. The disk is 3 feet 6 inches in diameter and nearly fills the entire corridor. It is possible to maneuver around the disk, but with only 3 inches to spare on either side, a Dexterity check will be required from all but thieves, who may use their *climb walls* chance if it is better.

Any person touching the disk, by stepping into it, by touching it accidentally, or by attempting to mark it for future reference, will be teleported. If a coin or other object is thrown onto the disk, it will remain there. If someone tries to pick up the coin, as soon as the connection is made with the coin, no matter how slight, he will be teleported. If, after a coin is thrown onto the disk a party member steps onto the disk, the party member will be teleported, leaving the coin untouched. That the party is to use the disk is found in the

inscription over the front door.

8b. The Maze of Light

The light in the room is blinding, with thousands of torches illuminating the space. The torches dance and move together alongside thousands of faces, also all the same.

This is a maze of mirrors made of highly polished, white marble. The stone will reflect clearly the light brought to the room as well as the faces and actions of those transported here. When judging this encounter, the DM should remember that anything that is done will be reflected infinitely. Thus, if a coin is placed on the floor, it will appear reflected in every direction.

By careful thought, the maze can be defeated. Unlike other mazes which may be solved by always turning in the same direction, this maze is made up of a series of free-standing surfaces. If the party can find an exterior wall, they will be able to solve the puzzle.

One of the best ways to solve the problem is to reduce the amount of light to a single source, and then hood this one as much as possible. The party can then link hands or rope them selves together, and begin to fumble through the maze. If a free-standing mirror is encountered, the front of the party will usually be able to circumnavigate it to see the last member of the party going round the corner.

9. Entry Corridor of Chinisk Ambar

A long, narrow corridor extends into the darkness to the left. Across the hall is an arched door, above which is a mosaic calligraphy. The door is of wood bound with iron with the latch on the left and the hinges behind the door to the right, as shown by the large, reinforcing straps riveted to the door on that side. The door pushes open to the right.

The corridor is blocked at the left end by rubble and sand, and so the door must be breached before the party can continue. The latch shows no sign of being trapped, but when lifted, it will not function. Everything about this door is the opposite of what would be expected from the description.

Depressing the latch, not lifting as expected, causes it to release the door catch. But instead of releasing a catch on the left side of the door, as expected, it actually releases a catch on the right. Furthermore, the door, instead of pushing open to the right as expected, pulls open to the left. Thus, by pushing against the door while lifting the latch (which is what would be the expected method of opening the door),

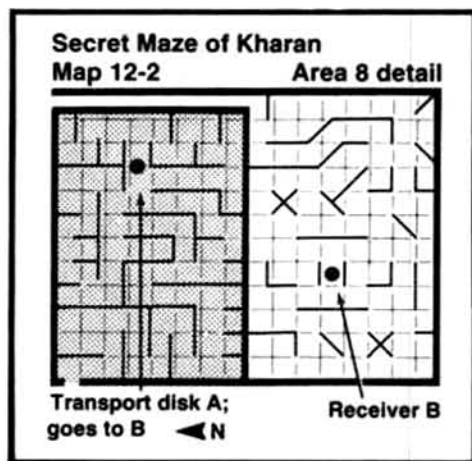

nothing will happen except to seat it more firmly against the frame and to secure the catch more fully.

The door can be opened by depressing the latch and pulling firmly. There is enough leverage from the placement of the latch to begin to open the door. Once started, it is an easy matter to pull the door open from the right side with the hand.

10. Library of Chininsk Ambar

The room is a shambles; smashed furniture, broken chests, and shards of pottery lie everywhere. From somewhere under the mound of refuse in the center of the floor, the odor of something long dead permeates the room. The walls, ceiling, and floor of the room are made of cut stone. There are no visible doors.

The party can uncover the bodies of four adventurers. They are desiccated and without bones. They, too, have become skeletons and are now a Random Encounter.

Against one wall, under a heap of refuse is a small, brass lamp, its surface heavily wrought with signs and symbols of ancient religions. It appears to have a value of about 20 sp, but when rubbed in the traditional manner, an aerial servant will appear. It is El-Tarifa, once major domo to Chininsk Ambar. When the city was abandoned, the master choose to remain to the last. El-Tarifa stayed with him, maintaining the household as he had done in the past, even after the old cleric's death.

The slain adventurers came upon the library and began to ransack the place. Accidentally, they released El Tarifa, whom they battled to their own deaths and to nearly the death of the old servant, hence his much-reduced hp. El Tarifa, too tired to clean up the damage done, retired to his home to recover slowly.

After surprising the party by his appearance, he will plead desperately for them to help

clean up the room. If they do, he will show them the small safety-catch that activates the wall that will allow their escape. He will also promise to go with them in his lamp and do one act of kindness for them as long as it is of a good nature. When that act is completed, he and his lamp will return to Phoenix to await the re-birth of the city.

The wall toward the left as the PCs enter (street side of the room), although it appears sound, is made of a very light material and is trapped to come crashing down into the room. When located (half normal chance to find secret doors), the triggering device may be tripped. Then, the wall will begin to tremble, and, with a mighty heave, it will come crashing down into the room, its blocks of stone bouncing everywhere. The blocks are actually made of a light material that will do no damage, even if they strike a person on the head. After passing into the next room, the wall may be easily reassembled to regain its original shape.

Aerial Servant: AC 3; MV 24"; HD 16; hp 8; #AT 1; D 8d4; SA surprise on 1-4; SD can be hit by magical weapons only; AL NG.

11. Sitting Room of Chininsk Ambar

This room is furnished in spartan, yet comfortable, chairs and stools. The right-hand wall is pierced by two doors, but the room is dominated by the huge carving of a skull in the opposite wall. The carving is as tall as the wall itself, and so deep that it reveals the room beyond through the eye sockets and nose hole. Above the carving, runes reform to read: "Death to all who enter here."

Through the carving of the skull can be seen an empty room, completely devoid of any markings save the brown stain on the opposite wall, just above the floor.

The room is of no value, and the furnishings are not worth saving. The room, however, is completely safe, regardless of the skull carving.

12. Death Trap of Chininsk Ambar

This room is empty save for the carving of a skull on the left-hand wall, through which may be seen the sitting room beyond. The stain on the right-hand wall is just above the floor.

The whole room is a hinged-floor trap that may be activated by anyone walking upon it. The runes over the skull in the sitting room warn of this trap. The stain is part of the trap: the bait, so to speak. When weight is put on the

floor near the right-hand wall, the entire floor will tip, dropping anyone in the room into a pit below. The floor will then snap shut.

A sand timer will render the floor safe and inoperable for 24 hours. Magic, of course, may be used to circumvent the latch, or the trapped PCs may escape through a tunnel dug by an industrious dwarf who became trapped here. The tunnel leads to a cellar that has a trap door opening into the Hall of Khalif Murbek (area 7). Raising the trap door will place the unlucky adventurer directly in front of the *mirror of opposition* there, though this will not be noticed until the PC looks behind the trap door. Retreating into the cellar, tunnel, or pit will not give any protection from the duplicate from the mirror, who will pursue and attack to the death.

13. Ballroom of Chininsk Ambar

As soon as any light enters this enormous room, long, hanging crystals that extend from the ceiling reflect it, giving full illumination. The roof reaches 50 feet above the highly polished floor, and the walls are heavily adorned with frescoes of dancing nymphs, satyrs, and legendary beasts. To the right is a dais raised 6 feet above the floor and topped with a stonework screen that extends to the ceiling. A small set of stairs to the left and right of the dais connects it to the main floor. Three doors open in the opposite wall.

The ballroom of Chininsk Ambar was famed as the place where any and all could dance. As the first party member enters the room, music will begin to emanate from behind the musicians' screen above the dais. As more and more party members enter the room, the music will get louder and more vibrant. When three or more PCs are on the floor, it will begin to rock and sway in time to the music.

The entire floor of the room is suspended on spring-loaded gimbals. Its motion will make it difficult to stand, getting progressively more difficult as the tempo of the music picks up. Anyone attempting to walk or run across the floor must make a Dexterity check three times to do so successfully. The first save is made normally, the second at a penalty of +3 to the die roll, and the third at a penalty of +6 to the die roll as the floor sways and tilts faster and faster. Anyone falling will take 1-2 damage points from the fall, and may make another Dexterity check with a penalty of +6 to rise again. Crawling is possible, but undignified. The best way to cross the room is by dancing. Anyone dancing his way across the floor, no matter how clumsy or how encumbered, may do so with no saving throws necessary. This is, after all, a ballroom!

14. Entryway of Chininsk Ambar

A long, narrow corridor extends into the darkness to the left. Across the hall is an arched door, above which is a mosaic calligraphy. The door is of wood bound with iron with the latch on the left and the hinges behind the door to the right, as shown by the large, reinforcing straps riveted to the door on that side. The door pushes open to the right.

Although this door looks like the one encountered earlier, there is nothing devious about it. It is not locked and opens easily.

15. Chandelle-Glissade

The first PC who steps through the door will find himself on an 18-inch-square platform at the top of a slide, which spirals counterclockwise downward. The next PC to step through the door will displace the first, sending him down the glissade, and so on.

The room is a long, gentle spiral that turns counter-clockwise as it falls. The walls join the floor in an easy curve and are as smooth as glass.

The easiest way to descend is to slide. Phoenix residents and visitors would descend on pillows or rugs, and the slide was oiled daily to eliminate abrasion. Party members who slide down will take 1d4 damage points from the abrasive sand and dust that has settled in the grooves of the glissade's construction. Any who try to walk down must make a Dexterity check or fall, taking 1d6 damage points from the fall in addition to the 1d4 points from abrasion as they descend willy-nilly. Those sliding down the glissade will gain speed as they move faster and faster, until they are deposited unceremoniously onto the street, the cushions that would break their fall long since gone.

Any who would climb up the glissade will face real difficulty. The climb is easy at first and then becomes steeper and steeper. The climber will lose his footing and slide to the bottom unless precautions are taken. At first he must climb on all fours, and then he will be reduced to crawling flat on his belly, pulling himself along with his palms pressed flat on the smooth surface. The surface is hard enough to resist iron spikes.

16. Baths of Garimsharr

An immense building of rose-colored stone faces the avenue and rises to the sand above. Mountains of sand and rubble sweep around the building from both sides, but the three main doors in the center are still open.

16a. East Gallery

Read the following when the building is entered:

Within, the archways open onto a long gallery 10 feet wide. It extends almost the entire length of the building and stands 10 feet off the main floor. Stairways down to the main floor terminate the gallery on either end, with domes filling the space to the end walls.

There is nothing of value to be found on the gallery.

16b. Main Floor

When the PCs descend to the main floor and provide illumination for the building, read the following description:

Three sets of pillars, 2 feet in diameter, support a vaulted roof that rises 70 feet from the floor. The base of each of these columns is a tub filled with soil and the shriveled remnants of trees.

A row of pillars, each one ornately carved to represent legendary beasts and equipped with four oil lamps, support the gallery just inside the main entry. A colonnade and gallery, identical to that on the east wall, runs along the west wall; sand has poured in the archways to the east, piling onto the gallery and spilling onto the main floor.

Set into the floor between the columns are four, large depressions, attesting to the building's use as a public bath. Around the pools are marble benches.

Four domed rooms, each about 20 feet wide, 10 feet deep, and 10 to 15 feet high, stand in the corners of the building, at the ends of the colonnade. Beside each is a stairway to the gallery above.

There is nothing of value to be found on the main floor, inside the colonnades, on the western gallery. In the center of the bathing pools, however, are the drains, each covered by a drain cap. These caps indicate that the drain itself is 2 feet in diameter, easily wide enough to fit a man.

As soon as the first cap is lifted, a wraith imprisoned below will surge out. The wraith is the spirit of Krinos Pandipolous, the manager of the baths during the last years of the city. He was so evil that when the city was abandoned, he was chained to the benches in the changing room, cursed by all the departing clerics, and left to die. He has haunted the ruins of the city, gathering as minions skeletons from fallen adventurers.

In the first round, the wraith will attack the PC lifting the drain cap. In the second round,



the wraith will withdraw, calling to his aid the skeletons that are in the changing rooms, if they have not yet been disarticulated. The third round, the wraith will join battle again. Any remaining skeletons will join the fray in the fifth round. The skeletons and wraith will defend this place to the last, retreating down the drain if turned by a cleric.

If the PCs do not investigate the drains, the wraith will appear from one just as they pass the pools for the last time. The object is to give the players the hint that the drains and sewer below are worth investigating.

Wraith: AC 4; MV 12"/24"; HD 5+3; hp 31; #AT 1; D 1d6; SA Energy drain; SD Silver or magic weapons needed to hit; AL LE.

16c. Changing Room

This small room is lined with benches, and there are hooks set into the walls for clothing. A large, ten-spouted oil lamp hangs in the center of the room suspended from the 15-foot domed ceiling.

The changing rooms may contain skeletons, created from the remains of dead adventurers who cursed the gods that put them here; they were, in turn cursed, to wander Phoenix for eternity, or until they are laid to rest. There are only 13 of these monsters in the ruins, turning up as a random wandering monster in any of the Encounter Areas 1-16. Each skeleton may be destroyed only once, and any encountered and destroyed as random encounters will not be encountered here. Any of the 13 skeletons that have not yet been destroyed will be in the changing rooms. To determine how many skeletons are in the changing rooms, first determine how many skeletons have already been destroyed. Then, for roll 1d6 for each of the four changing rooms, adding the number appearing in each room until the total of 13 is reached.

If the skeletons are not discovered and destroyed before the wraith is encountered, they will come to his aid, arriving to join battle in the 5th round after he appears. If they are discovered and turned while in the changing room, they will attempt to escape to the main floor, where they will open a drain cap and release the wraith.

Skeletons: AC 7; MV 12"; HD 1; hp 1d4+4; #AT 1; D 1d6; AL N. See description for numbers.

17. Sewer Tunnel

A 2-foot-diameter drainpipe leads down into darkness at least 20 feet below. An ancient smell of decay drifts upward from the sewer beneath.

Read the following when the PCs descend the drainpipe.

A 6-foot-wide tunnel, 10 feet tall from its flat bottom to its arched top, runs north and south below the drains. Its floor slants slightly down to the north, where the tunnel disappears around a bend to the right. The tunnel is filled with exceedingly fine spider webs and smells of decay.

The tunnel is empty except for the tiny red spiders who live there. The first PC through the tunnel will have to defeat the spiders or they will attack the other members of the party as they travel through. The spiders are so small as to pass almost unnoticed until their presence is announced by a fierce itching that follows their bite. They are blood-drinkers and are attracted to any warm blooded animal. They crush easily, leaving a smear of blood to mark their passing.

This is not meant to be a deadly encounter, but it may turn out to be dangerous if the PCs do not think. If the PCs do nothing about the webs, first determine how many spiders are in the tunnel, then roll 3d6 to see how many will attack the first PC to pass through their webs. If the adventurer just crawls through the infestation, he will crush 2d4 spiders; 1d4 of spiders will be able to crawl inside his clothing and attack him as though he were AC 10. The DM should keep track of how many have attacked and been killed.

The tunnel connects to the main sewer tunnel that runs north and south under the street. Though it is blocked to the south by sand from a cave-in, it is clear for a short way to the north, where there is a man-hole about 20 feet north of the connecting point. North of the manhole about 10 feet is a pile of sand nearly, but not quite, blocking the sewer.

4d6+10 Red Spiders: AC 8; MV 6"; HD 1/4; hp 1-2; #AT 1; D Nil; SA poison; AL N.

18. Statue of Set

Read this only if the party leaves the sewer via the manhole just north of the baths.

A circular roadway surrounds a pedestal on which is a 25-foot-tall statue of the god Set, carved out of black stone. He stands with his right hand pointing down the street toward the south. In his left hand, held against his waist band, he holds a carved stone bottle 4 feet tall and 1 foot in diameter.

Beneath this statue, rising up from the sewer below the street is a shaft into the pedestal of this statue. There, voluntarily imprisoned in a brass bottle that is identical to the bottle held by the statue, is Aeraldoth, the Djinn Vizier.

There are two ways that the party may find the bottle. They may destroy the statue and discover the secret place "beneath Set" as told in the legend. Or, they may continue past the manhole and find the shaft rising into the statue's pedestal. When the PCs gain the bottle they can see it is 4 feet tall, with a bulbous bottom 1 foot in diameter and a long neck. The stopper is engraved with the magical rune for air. Pulling the stopper has no effect, for to release the djinn the PCs must say the word of command *atmosphryeeno*. This is explained on the mark that Martek had caused to be placed on the palm of the wife of the sheik of the Oasis; the PCs can see this on the palm of the Princess Shadallah when they free her from Khalitharius in the Crypt of Badr Al-Mosak.

The bottle cannot be transported from Phoenix. When removed more than 100 feet from its hiding place, it will teleport magically back here. If the PCs have not yet freed the princess, they will not be able to release the djinn. They should be allowed to escape Phoenix, possibly by climbing clear via the baths (area 16) or the administrative building that stands behind the baths. Entrance to this building, which the DM must describe and map, may be gained by removing the sand that flows through the entrances on the west gallery. The dome of this building stands free of the sand. Once they know the secret, they may return (via the same way they left?), regain the bottle (perhaps more heavily protected by Khalitharius' minions), and free the djinn.

Either way, once the PCs pull the stopper from the bottle and speak the command word *atmosphryeetno*, read the following:

As the word leaves your lips, a blinding flash of blue lightning leaps from the container, followed by a peal of thunder. The statue of Set is pulverized into atoms, swirl-

ing away in a gust of wind. Sand and rocks from the dome above rain down into the street, and clouds of choking dust rise from the sand. The bottle, knocked violently to the ground, begins to spin, emitting a cloud of thick, icy-blue smoke. The smoke rises and coalesces to form a 30-foot-tall djinn, his arms folded and his eyes glaring.

Slowly the apparition begins to circle the base of the ruined statue. Faster and faster he moves, and the air around him begins to form into a tornado of dust. The wind swirls, tugging at clothing and equipment. Faster and faster the djinn moves until he is nothing but a blur of dust, sand, blue smoke, and a giant head. In one final movement, all who watch are swept up in the tornado. Equipment and loose clothing are torn off as each of you tumbles, alone and disoriented in the roaring maelstrom.

In one spasmodic burst of energy, the djinn breaks through the dome of sand that covers the city, whirling out into the light of the desert. In a cloud several miles high, he roars a challenge to Khalitharius, the Evil One, and then flies off to do combat.

The dying wind drops you gently to the soft sand, stripped of your weapons, loose clothing, and equipment. As the cloud disappears into the desert, the sky rains down the missing articles, the heavy ones first.

All around you, the desert sands stretch away to the horizon. But now, there is a great gaping hole exposing part of the city below, and through the sand protrude hundreds of roof-tops. The lost city of Phoenix, like the legendary bird, is beginning to emerge from its own ashes.



Chapter 13: Skysea / Medinat Muskawoon

Background

Medinat Muskawoon: Cursed City of Stone

The city of Medinat Muskawoon (City of Merchants) lay among the rolling hills bordering the fertile valley of the River Athis. Numerous small streams coursed through the rugged hillsides that surrounded the five smaller hills upon which the city lay, combining to form a lake called Me'at Halwa (Sweet Waters), around which much of the city was built. The lake emptied into the River Athis, to flow northwestward and eventually reach the sea.

A broad avenue of limestone, rising from the subterranean depths, cut through the valley from the north, terminating in the city's central square. It was this outcropping of rock, in some places a mile wide, in others as narrow as a hundred yards, that first brought the city its wealth. Rising from the surrounding alluvial soils of sandy loam, this outcropping formed a natural road-bed from the north that brought travelers to the shores of Me'at Halwa. From here, the journey south to Pazar and Phoenix was made over more traditional ground along the banks of the Athis.

The limestone roadbed made Me'at Halwa a natural location for a city. Travelers from the areas of The Goldenflow, Semkhrun, Zindalankh, Ustann, and Phannaskul made Medinat Muskawoon a warehouse for all the wealth and merchandise of the north. Here the produce, brought down in high-wheeled carts, was transferred to the smaller, two-wheeled carts, donkeys, and porters that would carry the goods to the great cities and the small towns of the Athis valley.

Over the centuries of prosperity, Medinat Muskawoon grew from a small cluster of mud-brick warehouses into a thriving, multi-cultured metropolis. Within its square mile, more languages were spoken than in any like area of the world. On the streets could be seen the somber hues of the Unther, the dazzling raiment of the Uttermost East, and the steel-clad warriors of the then-primitive Inner Sea Lands. Each one looked with amazement on the other, and all dwelt in peace and prosperity. Until the curse.

When Amun-Re was murdered, the life-giving Waters of Athis stopped flowing. Without this water to green the valley and raise the level of underground water, the small streams that added to Me'at Halwa were not enough to keep the lake full. Soon it withered and vanished. On its banks, Medinat Muskawoon remained for a while, watching its life-giving water slowly disappear.

With the loss of the River Athis, trade across the expanding desert became troublesome, then arduous, then impossible. The inhabitants of Medinat Muskawoon fled toward their

homelands. Those who left first carried their entire households. As the travelers evaporated, so did the means of escape. Those who had chosen to remain when all hope of resurrecting the city had passed were faced with the bleak prospect of dying of thirst among the abandoned buildings, or, forsaking all that they had held dear, buying passage on one of the increasingly infrequent caravans that still came to Medinat Muskawoon.

The price of passage became exorbitant. Men with a sharp eye for profit saw that the desperation and despair of Medinat Muskawoon were sources of fortune. Arriving at Medinat Muskawoon, they would auction the spaces available in the out-going transport. The desperate inhabitants would pay anything to escape, and the transporters were made wealthy by the desperation of the remaining population. As the number of rich remaining in the city dwindled, so did the number of money-hungry dealers willing to cross the bone-dry desert. The remaining population became frantic. When one of the caravans made its way into the city, rabid crowds would gather to bid for the remaining seats.

On the last occasion, the population was so mad to obtain transport, that a riot broke out in the square. People were trampled by the starving, wild-eyed mob. The caravaneers were torn limb-from-limb, and the animals killed where they stood. The crowd drank the blood of the fallen animals, and so for a little while the animals did serve as a salvation for the lucky survivors.

Soon, however, those who had survived the violence had reason to envy those who had perished; they, at least, had passed beyond starvation and thirst. No caravans came again to Medinat Muskawoon. The population, ravaged by heat, thirst, and starvation, unassisted by the gods whose temples they had defaced, perished. Medinat Muskawoon slept under a growing blanket of sand, its monuments slowly eaten by the scouring effect of wind-blasted dust that eroded all that men had worked so long to erect.

But treasure remained, at least in legend and rumor, and there were those hearty ones who saw the ruins of Medinat Muskawoon as a treasure hoard. For many years, an occasional party of treasure-hunters would venture into the desert to find the lost city, but few ever returned. Those who did return arrived at the edges of civilization babbling about ghosts who rose in the night and stalked the abandoned streets of the city. They told of seeing their comrades touched by those ghosts, and then shrivel to dust before their very eyes, all the water in their bodies drained away. They told of nameless and faceless evil, of a curse laid upon the city. They described the skeletal stone ruins that watched as death stalked the stone streets and the limestone causway. It was

from these unfortunates that Medinat Muskawoon got the name that has marked it ever since: the Cursed City of Stone.

The Creation of Skysea

It was 50 years since the last inhabitant walked the streets of Medinat Muskawoon. In that time, the Efrete Pasha Khalitharius had taken up residence there, drawing about him minions who would serve him, and using it as a base to terrorize the desert peoples far and wide. Thus it was to this place that the Archmage Martek tracked him and his army of undead called the Malatath.

The confrontation that followed is still told as a legend, the originator being one of the camel drivers from the caravan that brought Martek to the area. The legend is given below.

The caravan had made the crossing of the Plains of the Purple Dust from Zindalankh without incident. The limestone road was still there, rising above the shifting sands of the dead land around. The cluster of hills that had marked Medinat Muskawoon were easily found, and the caravan made ready to confront the efrete. Then strange events began to overtake the expedition.

Members of the expedition reported that at night they had visions of the city as it had been. At first, these tales were discounted as mere dreams, engendered by the legends and the history of the city. Those who told of the visions were scorned and told to keep silent. For a time this sufficed, but the reports began again, and this time they were from responsible members of the enterprise. Then, one morning, the first corpse was found.

The cadaver was so shriveled that at first it was thought to have been either one of the original residents, mummified by the dry heat, or that of some ancient traveler who had stumbled into the area, but subsequent search proved it to have been one of the night-guards. There were no marks of violence to be discovered, and there was no evidence of a struggle. It was apparent that every drop of fluid had been drained from the corpse. The skin was hard and dry, and when the body was moved it was stiff and brittle. The lips were pulled back to reveal the teeth in a macabre grimace, and the sightless eyes bulged from the shrunken face.

For the next two nights there was a recurrence of the event, said by Martek to be the work of The Malatath. Each morning would reveal another corpse, and a roll call would prove that a night-guard was missing. Panic, not the screaming kind, but the deep, stomach-churning, leg-weakening kind, gripped the expedition as Martek made his final preparations. At night the ranks of the survivors closed around his tent, staring fearfully into the menacing dark, unwilling to close their eyes.

One morning the camels, tethered outside the ring of guards, were found dead. The next morning half the water barrels were found to have sprung leaks and drained away into the sand; there was no moisture even in the bottoms. The surviving water was brought into Martek's tent. No one slept. At last, Martek was ready to face the efreit in single magical combat.

What happened next is best told in the words of that more-than-half crazed survivor:

As Martek began his chant at the stroke of the darkest hour of the night, figures began to appear beyond the light of our fires. At first we thought they were merely from our fevered imaginations, but they became clearer and clearer. Here were The Malatath, the murderers of our comrades. They swayed back and forth, their mouths open in wordless chants, their arms moving over their heads. Some carried weapons, but most were armed with their hands only, upon which their long fingernails were hideous to behold. Many were covered with what appeared to be blood, and there were some with horrible wounds that reflected the light of our fires. They stared at us and began to come closer until they were within the circle of light.

We drew our weapons and prepared to defend our patron, who would soon be too busy to defend against them. There was no place to which we could escape, so none of us sought to run. In the center of the circle, high on a dais we had erected for him, stood Martek, surrounded by fire of his own creation, for he knew that the only way to best the Evil One was with his own weapon, magical fire.

Martek chanted and wailed, his arms out-stretched toward the murky sky. There were no stars, and the sky was as satin-black as the shroud of a wealthy man. The more Martek chanted the higher the fire around him rose. The higher the fire, the closer came the uninvited apparitions.

As his incantation reached its climax, a gigantic figure appeared in the night sky above. He was clad in a glowing headdress, his arms covered with golden ornaments the like of which I have never seen before. Three times he circled our convocation. His eyes never left the figure of Martek. As he moved, the fires around the mage grew higher and higher. Finally, the figure of Martek was completely covered by his own fire. It was then that The Malatath attacked.

We had fallen back until we were shoulder to shoulder with almost no room to use our weapons. When the final rush came upon us we were at a disadvantage. I saw

the man on my right go down under the sweeping attack of a clawed arm, his body shriveling ere it touched the ground. He died silently. Others were not so quiet, and I heard screams I shall never forget.

Peshnar, my friend who stood to my left, and I stood back-to-back the better to defend each other. As we turned in this way, the circle was broken, and The Malatath poured through our shattered ranks. I looked quickly to my right, in the direction of the dais, but I could discern nothing. The wall of flames that had begun on its surface had enfolded the entire structure.

I remember little else. The fire grew and grew. I remember hearing the words, "Thou little man, thou mere mortal. Tamper not with those things beyond your ken. May the fire of the desert and the fire of the sun scorch you and yours for the next score years." The voice of Martek came clear and cold across the battleground, saying, "Fires that cleanse surround thee, Khalitharius, at my command. Fires of Ra, of Apollo, of Heimdal, snuff the burning hate. Fire of justice, which burns in the hearts of the true, quench thee, Khalitharius, NOW."

There was a burst of many-hued fire that engulfed us all. I was thrown clear, and when I awoke, I could see a sea of fire many mile broad, burning as if fueled by the sands of the desert itself.

The magical fire, kindled by Martek in his successful bout with Khalitharius, burned for twenty years, creating a huge sea of melted sand. After they died away, that sea hardened to glass and became known as Skysea. Now, only the intense heat reflected from its surface remains as testament to its fiery origin.

The Star of Melos-Pelar

The Star of Melos-Pelar is a fist-sized, clear amethyst of the deepest purple, the shape of an egg and faceted all around. It has the power to locate the Citadel of Martek.

In making preparations for the eventual return of Khalitharius and the ultimate plan to banish him forever from the Forgotten Realms, Martek chose the ruins of Medinat Muska-woon as the resting place of the final gem that would light the way to his tomb. Just as he had placed the other Star Gems in places where a band of heroes could find them and test their mettle doing it, he placed the Star of Melos-Pelar in the Cursed City's ruins.

He chose the Temple of Ra as its resting place and protected it with powerful guardians from that god's legend. Ra was chief among the Egyptian pantheon and believed to be the creator of the universe. His legend says that when, in his old age, he found that man was plotting against him, he invoked the eye of Hathor to

massacre mankind. Finally appeased, he decided to quit the earth. From then on, his travels by boat across the sky have governed the movements and life of man.

Martek caused the pylons that stand at the front gate to the temple to be guarded by Ra's eyes; just as any who plotted against Ra would be destroyed by the eyes, so will any adventurer seeking to get the Star of Martek be destroyed by the Eyes of Hathor carved on the pylons. Inside the court, Martek placed poisonous snakes; just as the snakes, who are Ra's enemies, swarm against all those who worship Ra, so will the snakes attack any who enter. Martek equipped the lotus-capped pillars that support the facade of the inner shrine to release a magical gas; just as the fragrance of the lotus blossom, from which Ra sprang at birth, brings forgetfulness, so will the gas released by the pillars cause those that pass through it to forget why they are there. The last barrier Martek erected is a bottomless void; Ra and Isis fled to a deep swamp to avoid the wrath of Set after that god had murdered Osiris, and this trap teleports any who fall into it there.

Martek then used his magical prowess to prevent further decay of several large buildings and temples throughout the ruined city. In each of these he placed keys to defeating the guardians of the Temple of Ra.

At the Shrine of Balder, he placed tokens that would charm the Eyes of Ra at the entrance to the temple. In the Temple of Prometheus, he enchanted the brazier there to give fire that would defeat the snakes in the temple's inner court. In the Temple of Horus, he placed magical gems in the eye-sockets of the statue to the god. He enchanted these to be given to one who would ask the god for his aid; the gems would enable their possessor to fly rapidly through the magical gas.

In several of the ruined public baths, he altered the golden drain caps to form parts of an interlinking bridge that could cross the void. Fourteen of these he created in all, representing the fourteen parts into which Set dismembered Osiris. Just as Isis was able to find only thirteen of these parts, Martek enchanted them so that when all fourteen of the bridge links were brought together, one would disappear.

Finally, Martek erected the obelisk and the three Oracle Stones that border Skysea. He enchanted the obelisk so that it would begin to emit clear musical tones when someone removed the Star Gem from the Temple of Ra. He laid enchantments giving the bearer of the Star Gem a beacon that would lead him to the Pillars that could call his citadel from its place in the sky.

Placing the Star of Melos-Pelar into an indentation in the base of the obelisk will cause the stone to glow. Thereafter, if the stone is held out, it will glow more or less brightly depending on the location of the Pillars of

Martek. When the gem is held directly between the holder and the Pillars, it will seem to flare into brilliant light, creating a beacon as foretold by the Oracle Stones.

Expected Play

Skysea

There are two ways that the PCs can cross Skysea to get to the Cursed City of Stone. The party can take one of the grounded cloudskates and use it to sail across Skysea to the city, or they can be captured by the glass pirates and carried there.

Cursed City of Stone

The search for the fifth Star Gem of Martek in the cursed ruins of Medinat Muskawoon will require intelligence, thought, and some daring. The party must first discover the location of the missing gem, and then remove the gem from its resting place. The legend inscribed around the base of the huge black obelisk should lead the party to the temple of Ra. Guardians have been placed there to forestall any common, causal adventurers from stealing the gem. The eyes on the piers outside the temple should be enough of a warning to cause the party to decipher the riddle on the obelisk.

In the buildings that remain, there are items that will help the party gain access to the temple's treasure. Martek, when he placed the Star Gem in the ruined city after his battle with Khalitharius, knew that many would attempt to remove it. He also knew that whosoever gained this end would have assumed great power. To assure that only those with great courage and a healthy streak of altruism attained that end, he placed the guardians on the temple of Ra. The other stones were guarded by their own warders. The mission of the party is to decipher the riddle and seize the stone.

The death of the city, the curses laid on it, and the subsequent use of major magics here have left the city a ruin. Due to the amount of magic expended here, the city has the tendency to absorb magic carried and used by the adventuring party. Thus, the DM can restrict the use of magic on the part of the party so that the adventure in the city becomes a test of thought rather than of brute force.

As the PCs explore the ruins of the city, they will find just enough of interest to whet their appetites for more exploration. The obelisk is the main reason for their being here, but they should have heard enough rumors about the treasure left in the city to inspire them to begin at least a cursory search. If they spend the night in the city, they will have a much more interesting time.

If you choose to use the Cursed City as a part of an on-going campaign, you may wish to plant clues to further adventures beyond the

one in which the players are now involved. The cosmopolitan nature of Medinat Muskawoon made it the center of trade for much of the civilized world. Trinkets from any society can be found here, and although they may not be important in this adventure, they could have great meaning for the party in the future. These trinkets are suggested in some of the treasure locations within the city as well as located by the notation "(Place optional treasure here)."

You should be careful not place too many trinkets before the party, or they may go in search of these rather than accomplish their primary mission of locating the fifth Star Gem of Martek. If this becomes a problem, a witnessed battle between Khalitharius and Aeraldoth should remind them of their goal.

A description is provided below for each of the 24 areas keyed on Map 13-2. Only those areas not in ruins will have any further detail. The party can use any of the standing buildings as a refuge for the night, providing that they deal with any inhabitants first. They may also remain hidden in one of the buildings when the glass pirates enter the city either looking for the party or on one of their normal visits. The glass pirates will come no farther than the paved area defined by the squares and esplanade unless they see the party. If they do, they will attempt to capture the party.

Temple of Ra

The Star Gem of Melos-Pelar sought by the party lies on an altar within the Temple of Ra (City Ruins area 17), where it was placed by Martek. It is heavily guarded by magic also laid down by Martek. The problems faced by the PCs can be overcome by solving the riddle on the Obelisk (City Ruins area 2) and gathering the magic mentioned there, magic that Martek placed in the surviving temples and public baths. Other ways may be found, but they are fraught with peril.

If the PCs arrive with the three magic items from the standing temples, they will have no trouble. The amber tears from the Temple of Balder (City Ruins area 20) will allow them to pass by the Eyes of Hathor (area 1). Torches lit from the brazier in the Temple of Prometheus (City Ruins area 10) will allow them to fend off the asps in the Courtyard (area 2). And the power of flight from the Temple of Horus (City Ruins area 9) will allow them to fly over any or all of the perilous areas. The golden draincaps from the public baths will allow them to cross the Deep Swamp (area 6).

It is very desirable to prohibit the PCs from using their own magic spells or devices in the solving of this puzzle. Its use will make the problems of the temple trivial and the search of the city unnecessary.

All of the guardians of this temple are magical, and it is intended that they should seem so

to the players. The snakes must be seen to be innumerable, and it might help establish the feeling of magic if they were to disappear upon death. If the DM wishes to diminish the danger, he can make the snakes be live and limit their number. In a similar way, the lotus fragrance is a magical gas, not a physical one. It is not intended to be circumvented by holding the breath or by breathing through a soaked cloth. The DM can diminish its danger by making it a physical gas, changing the saving throw to a save vs. poison and allowing physical means to counter it. Lastly, the void is not intended to be spanned by ordinary means, and any plank or similar object that could be carried in to help bridge the gap will not be supported by the magic; when any weight is placed upon it, the altar will begin to sink. The DM can diminish this danger by allowing the PCs to find a plank or similar object, as from a cloudskate or the wooden stakes along the esplanade; this could be carried into the temple and used to cross the void.

Skysea Encounter Areas

For play in this area, refer to Map 13-1 in the *Map Booklet*. Colored Map 6-3 provided for player use shows the surrounding geography.

Skysea Random Encounters

Check for random encounters once every six turns. A roll of 1 on 1d6 means that the characters encounter something. Roll 1d12 and use the encounter with that number from the table below.

Skysea Random Encounter Table

1. Purple Worm: AC 6; MV 9"; HD 15; hp 70; #AT 1 and 1; D 2d12/2d4 + poison; AL N; SA poison stinger in tail. Feeling the characters or the ship overhead, the worm will crash through the surface of Skysea and attack. The worm will appear right in the middle of the characters or next to their ship. Because the glass here is now broken up, the heat damage will not occur as long as the PCs are in the area. Treat the hole like another shoreline where there is no heat damage. Characters will take 1 point of damage per round for every 10 feet away they are from the hole.
- 2-3. 1d10 Skittercrabs: AC 3; MV 4"/(18)"; HD 4; #AT 2; D 1-6/1-6; AL N. These creatures skim the surface in their hard shells in search of soft food. They do not exist anywhere except on Skysea.
- 4-5. 2d10 Spectral Minions: AC 2; MV 9"; HD 3; #AT 1; D 1d6; AL NG. These appear as

wanderers walking across the glass sea. They are long-dead Raurindi who were caught half-way across Skysea when dawn came. On a quest for a new god to worship when death overtook them, they are cursed to stay here by the god they worshipped before. They will attack only if the party attempts to stop their trek.

- 6-8. 3d6 Glass Pirates: AC 2; MV 12"; HD 5; #AT 1; D 1d8; AL CE; SA hypnotic stare; SD immune to non-magical fire and heat. A dark cloudskate with a ragged sail will appear on the horizon, quickly closing with the PCs. Aboard are robed skeletons, which are the glass pirates manning the ship. When close enough, the pirates will leap from their ship. The only choice they will give the party is to surrender or to fight. The pirates will fight to the death. Even though they communicate telepathically, they do not reason.

They will take any captives aboard their cloudskate, thence to The Cursed Isle (area 5). There, they will skate around to the north side to The Narrows, and thence up to the Cursed City of Stone. Read the descriptive passages appropriate to this journey. The pirates will not go into the city, believing that powerful beings live in the obelisk in the city square. They will, however, tie their PC captives to stakes along the shore and leave them as sacrifices. Then the pirates will leave. They will return the next morning, and, if the PCs are still tied to the stakes, they will take the PCs out in their cloudskates and make them walk the plank.

9. Wanderer: AC 0; MV 12"/12+"; HD 10; #AT 1; D 1-10; AL CE; SA magical attacks. The form of a beautiful woman in white flowing robes appears on the sea of glass. She will treat the PCs kindly unless they attack her. If she is attacked, she will cause a *flame strike* to hit the attacker, and then she will leave. If she is treated kindly, she will point the way to Martek's tomb and tell the PCs that unless they carry the famed Star Gems there is no hope for them once they have entered Martek's tomb. She will say that one of the Star Gems lies on the island, which can be seen shimmering in the distance. With this she will leave.
10. Spectral Minion: AC 2; MV 9"; HD 3; hp 20; #AT 1; D 1d10; AL LE. This minion is a knight who has wandered the desert for centuries. It will attack the party without any concern for its own safety.
11. Dead Party of Adventurers. Lying face down on the surface of the glass sea, five

sets of scorched clothes and bones give silent testimony to the fate of those caught by daybreak. One of these poor souls fell face forward and by so doing, protected his pack with his body. An ancient, scorched, but readable, map of Skysea and Mediat Muskawoon can be found in the pack. The map should mark the location of the Oracle Shrines of Martek and the Pillars Of Martek.

12. Ghostship: AC 5; MV 0"/24+; HD 10; hp 60; #AT 4; D 1-6; AL CE. A huge cloudskate of intricate design can be seen on the horizon, motionless upon the glass. If the PCs approach and board it, the ship will attack them, using its beams, ropes and davits. It will chase the PCs, even if they flee in their own ship. It is up to the DM to make the ship's attacks interesting and believable. The ship's spirit can be exercised or destroyed by giving it 60 damage points. The ship will not burn because it was made to travel in the heat of Skysea.

1. Approach to Skysea

Ahead, the ground seems to drop away into a deep sky. To left and right, a shoreline of sand dunes is formed as the world abruptly ends, hanging in the desert sky ahead. Land's-end extends to the limits of sight in both directions.

Only upon close inspection is the true nature revealed. A huge sea, its surface glassy smooth, lies ahead, mirroring the dunes of the shore and the clouds above. No opposite shore may be seen through the shimmering haze... only the sky and the clouds below merging into those above in the distance.

As you get closer to the shoreline, the air becomes very dry and so hot that it is painful to breathe. At a great distance to the north there is a dark island, seemingly afloat in the sky.

2. Grounded Cloudskate

This Encounter Area is the same as Desert of Desolation area 22 on Map 6-1.

A strange metallic platform juts skyward, half-buried in the sands of the shoreline. A few feet away, a tall metal pole also pokes out of the sand. There is a crosspiece wrapped with bundles of woven bronze on the pole. The slanting platform has a pair of large gleaming blades mounted under it. There is a long thin blade hanging in the air on the side of the platform.

The buried object is a cloudskate, the skyship

of legend. It can be used to cross Skysea during the day or the night, as the woven bronze sail converts the Skysea heat into movement. The hull of the cloudskate absorbs the heat from the mirrored glass and converts its energy to a magical glowing force between the runners. This lifts the ship off the glass, so that the runners barely touch the surface. The runners and the rudder are diamond-studded to give purchase against the glass, much like an the edge of an ice-skate blade does on ice. In motion, the rudder cuts into the glass to steer the ship, overcoming the force exerted by the runners.

It will take 3d6 turns to dig out the grounded cloudskate. The PCs will have to identify it as some form of ship before they can use it. Anyone riding in a cloudskate during the day will feel very hot, almost scorching, but will not take any damage so long as he stays in the ship. Travel will be at one mile per hour during the night, two miles per hour at dawn or dusk, and four miles per hour during daylight.

3. Surface of Skysea

This Encounter Area corresponds to Desert of Desolation area 23 on Map 6-1.

The surface of this sea of glass is almost perfectly flat, worn down by the winds and sand. Though the top surface is scratched and scarred, the sea is brilliantly reflective, mirroring the sky above, and the air above its surface shimmers in the heat it emits.

The glass averages 10 feet deep and is very hard. It will not crack, but small random pieces can be chipped from its surface. Fire heats the glass but does not damage it. The bottom surface of the glass is mirror-smooth and very reflective. The air above the Skysea is heated by the reflected desert sun.

All movement on Skysea is at half the normal rate unless some way is found to decrease the slipperiness of the surface. Because of the scorching heat of the desert sun reflected by the glass, characters on Skysea half an hour after sunrise will take 1 damage point per round for every 10 feet they are from shore, up to a maximum of 10 damage points per round. For example, a character walking 30 feet from the shore will take 3 points of damage every round.

4. Hot Spot

While the characters are on Skysea, there is a 10% chance per round of stepping into a hot spot, a place where the sun's rays are particularly concentrated. Hot spots move randomly as the sun moves across the sky and clouds cast shadows. Hot spots stay in the same place for only three turns, and there is a 10% chance per turn that a hot spot will move onto any stationary character. Anyone in a hot spot will

take 2d20 extra points of damage per round they remain there. Characters may save vs. breath weapons for half damage.

5. Isle of the Cursed

This Encounter Area corresponds to Desert of Desolation area 24 on Map 6-1. For play in this area refer to the section below.

The Cursed Isle Encounter Areas

This Encounter Area corresponds to Desert of Desolation area 24 on Map 6-1 and to Skysea area 5 above. Refer to Map 13-1 for the location of the Encounter Areas described below.

The party can enter the Cursed City of Stone in one of three ways: (1) by cloudskate that grounds against one of the outlying hills and thence overland to the city, (2) by cloudskate up the extinct river valley into the basin formed by the lake, or (3) taken to the city by glass pirates. If they arrive at the edge of the hills that surround the city to the north, west, or east, read the first boxed description and continue the adventure until they can see the city. If they enter the city on cloudskates, either with or without the glass pirates, read the second boxed description, making appropriate modifications as necessary.

1. The Tortured Hills

Ahead, the tortured profiles of hills rise to the right and left. Though lower in total height than The Dustwall through which the party has passed before, they seem deformed travesties of those rugged peaks. They are twisted and battered. Chunks of stone, hundreds of feet broad, lie scattered as if cast by a giant hand. Some of the rock has the appearance of being crushed by that same hand, squeezing the essence forth as fountains and oozeings frozen now for all time. Shards of rock, as sharp and pointed as a dagger's blade, leap skyward to dizzying heights. The hues of the rocks, stripped as they are of any softening by soil or growth, range from the red of fresh gore, through the brown of dried blood, to the ashen hues of long-dead flesh. A sticky-sweet smell is brought on the wind that howls through the crags.

The party can either attempt to cross the hills toward the city or try to circumvent them by traveling along the shoreline. Unless they have come ashore very close to the limestone highway that approaches from the north, and turn toward it, the trek along the shore will be long and arduous.

After leaving the shore line, the hills rise steeply. Hand-over-hand climbing is necessary, and it would be safer for the party to rope themselves together. For each turn of movement, play-

ers must make a Dexterity check or fail. Modify the saving throw by +1 for every 40 lbs. of equipment carried. If the saving throw fails, roll 1d6 to determine the amount of damage. If the PCs are not roped together and a six is rolled for damage, reroll 1d6 for additional damage, explaining that the PC has bounced off rocks on the fall, hitting ledges and the like on the way down. Repeat the process, giving 1d6 additional damage for each six rolled until no more sixes result or the PC has 0 hp.

2. The Shore Line

Movement is difficult through the boulder-strewn shore line. Soft-ball size rocks, loose and treacherous, mean that maximum attention must be paid. For every turn of movement, players will have to make Dexterity checks or their characters take damage from slips and falls. Modify the saving throw by +1 for every 40 lbs. of equipment carried. If the saving throw fails, roll 1d6 for the amount of damage. If a 6 is rolled, tell the player that the character has slipped and fallen out of control, twisting his leg and careening against shards of rock and glass for an additional 1d6 damage points. Continue this process for every 6 rolled

on 1d6 until no more sixes are rolled or the PC is at 0 hp. It should not take the players very long before they decide to hike over the hills.

3. The Limestone Causeway

From the shore, this natural outcropping can be seen only on the island's northwest side. It is brilliant white, standing out very plainly against the dark rocks. Read the following only if the PCs leave the cloudskate and traverse the causeway.

A white outcropping leads southeast straight through the mountain peaks, which flank it to either side. Its level, flat surface has been polished smooth, and it is apparent that it has been used as a roadway. So white is the roadway that it hurts the eyes even to look at it, and the reflected light rebounds from the rocks on either side to form an impenetrable barrier of light as to what lies beyond.

By shielding their eyes, the players will be able to move along the highway toward the city. Movement along the highway is without penalty. The PCs will not be able to tell what is



more than 10 feet away due to the intense light. If they continue to shield their eyes, they will be unhurt. If they attempt to see what is beyond, roll 1d6 for damage. For each damage point given, roll 1d6 for the number of rounds the PC will be blinded by the light. Once the party is about 2 miles from the city, the reflected light will dissipate to reveal the obelisk in the city square.

4. The Narrows

This passage to the Cursed City of Stone can only be seen from Skysea on the north side of the island. There, the brilliant reflection of the glass will be a guiding arrow through the peaks on either side. Read the following only if this passage is taken by cloudskate. The shoreline of The Narrows is the same as the shoreline elsewhere on the island.

As the cloudskate speeds over the surface, circling the north side of the island, a brilliant needle of glass seems to trust into the dark stone hills. This needle heads straight south, an opening between the jagged rocks that rise abruptly from the shore. It is certainly wide enough to steer the cloudskate through.

5. The Cursed City

As soon as the players have reached a position from which they can see the obelisk in the center of the city, whether that is from The Blasted Hills (area 1), The Limestone Causeway (area 3), or The Narrows (area 4), read the boxed description below.

Centered in the basin in the surrounding hills, lies a lake of glass, a narrow neck passing between the hills to the northeast. Its shoreline is paved with white stone, which also marks two squares, one to the north and one to the south. Centered in the square to the north, outlined against the shattered hills, a grey, stone obelisk rises sharply. A white-paved road passes to the northwest, connecting to a causeway that cuts through the blasted hills like an ancient scar.

About the obelisk, extending from the shore to the edge of the hills, the ruins of buildings lie scattered and crushed. Immediately bordering the two squares and the paved esplanade along the shoreline, lie buildings monumental in size, their walls broken and fallen in, now mere crumbled piles of rotten brick and weathered stone. To the east lies the ruins of the massive hippodrome, its cheering multitudes now silenced by death. Other buildings are smaller, obviously temples and shops. A

few still retain their roofs and look as if they could provide shelter.

The structures of the city are of two types: those destroyed by time and wind, and those which seem unaffected by those scourging elements. It is almost as though they were meant to stand, waiting for the arrival of an important messenger.

For further play in this area, use the maps for the Cursed City of Stone found in the *Map Booklet*. The key to the encounter areas is given below.

Cursed City of Stone Encounter Areas

For play in this area refer to Map 13-2 in the *Map Booklet*. This area corresponds to Isle of the Cursed area 5 on Map 13-1 and to Desert of Desolation area 25 on Map 6-1.

Cursed City Random Encounters

The city is quite dead. There will be no random encounters in the city as it is explored during the day. The fact that there are no encounters should begin to make an impression on the players. Nothing is alive in the city; even the purple worms that are found throughout the area, including under Skysea, do not approach within half a mile of the shore of this place. The city is known to be cursed, and no animal, sentient or not, approaches.

After dark, exploration of the city probably will trigger a series of random encounters. For each three turns, roll 1d6. On a roll of 1 or 2, a random encounter takes place. If there is an encounter, roll 1d6 to determine whether the encounter is a vision or an event. For every hour after dark, add 1 to the die roll until midnight; after midnight, subtract 1 for every hour. On a roll of 1-5, the encounter will be a vision; a roll of 6 or higher indicates an event. Roll 1d6 and consult the appropriate Cursed City Random Encounter Table to determine the encounter that takes place.

Cursed City Random Vision Table

1. Priest. A tall, distinguished man approaches from the darkness. He is fully illuminated, and a temple of some kind can be seen in the darkness behind him. He will appear surprised that the party member is in front of him. He smiles, extending his hand in greeting. As he does so, his face will become emaciated, the cheeks hollow, the eyes feverish. As the priest's hand reaches that of the PC, the priest will collapse and vanish.

2. Passing caravan. The PCs will become aware that the street they are on has become a busy thoroughfare, down which a large caravan of camels is approaching. The camels are as heavily loaded as any ever seen. The bundles on the beasts' backs tower above the animals, bulging out on the sides till they seem to block the entire street. From 30 feet or more, the camels and their driver seem quite real. From about 100 feet, the caravan leader gesticulates frantically for the PCs to clear the path. As the vision comes closer, it begins to fade until it vanishes.

3. Business transaction. Appearing suddenly 30 feet ahead of the PCs are three businessmen. Each is dressed in different attire. The men are haggling over some invisible item, but although the discussion is animated they are friendly. The man facing the party member will notice him, notify his partners of the approach, and move toward the party. As he does so, the other members of the trio will fade into the surrounding darkness. He stumbles, and when he recovers and regains eye-contact with the PC, his face will be drawn, his cheeks and temples hollowed. He stumbles again, and this time he will fall. A claw-like hand extends from his garment, clutching at the PC before also melting into the darkness.

4. Thundering chariot. A cry pierces the darkness, and the PCs find themselves in a crowded street. The panic-stricken crowd is scattering in front of the party and pointing behind them. All the people are shouting, but the babble of voices in many languages make interpretation impossible. From behind come the rumble of wooden wheels on stone. Approaching from the rear at a full gallop is a four-horse team drawing a chariot. The team, harnessed four-abreast, fills the entire street; there is no escape. As the horses approach they begin to fade, and as the first one reaches the PC, they vanish in silence. This is the only vision for which there is sound.

5. Elephant. A huge, grey elephant appears out of the darkness. It is tethered to an iron post driven into the ground. The elephant will not acknowledge the presence of the PC, and if nothing is done, will fade into the darkness within a minute. If the PC approaches the elephant, the great animal will sink to its knees and then fall to his side. If further approach is attempted, the elephant will wither until nothing is left but the bones. Further approach, and the bones themselves will fade into the darkness.

6. **Lovers.** A pair of young people sit side-by-side in a small, ivy-covered alcove, engrossed in each other. If they are not approached, the vision will fade in a minute. If approached, the boy will look up and smile at the approaching PCs, but the girl will collapse against his shoulder. As this happens, the boy will raise his hand as if to restrain the PCs. If not approached closer, the vision will fade. If the PCs continue to approach, the boy will turn to the girl, holding her closely in her arms. Both will become skeletal as the approach continues, fading into the darkness before contact can be made.

Cursed City Random Event Table

1. **A Warning.** Materializing out of the darkness, a spectral form appears. The figure is cloaked, its feet disappearing into the darkness that seems to intensify around the figure. Slowly raising its head to reveal glowing eyes under the hood, it holds up a skeletal hand and speaks, "Only brave men need continue here. Beware all others in this place." The spectral shape fades from sight.
2. **Ghost Thief:** AC 8; MV 9"; HD 5; hp 24; #AT 1; D 1d6; SA age 10-40 years; SD magic or silver weapons needed to hit; AL CE. The ghost will appear behind the last party member in the affected group. It will attack with surprise; normal saving throws are applicable.
3. **1-3 Ghost Fighters:** AC 3; MV 12"; HD 7; #AT 1; D 1d8; SA age 10-40 years; SD magic or silver weapons needed to hit; AL LE. The fighters will appear in front of the party, blocking passage. They will attack immediately. Saving throws vs. fear are applicable only on the first encounter with these ghosts.
4. **Wight:** AC 5; MV 12"; HD 4+3; #AT 1; D 1-4; SA energy drain; SD silver or magical weapons to hit; AL LE. The wight appears from the direction of the closest unexplored ruin.
5. **Wraith:** AC 4; MV 12"/24"; HD 5+3; #AT 1; D 1d6 + energy drain; SD silver or magical weapons needed to hit; AL LE. The wraith will appear from the direction of the nearest unexplored ruin.
6. **The Last Caravan.** This encounter will take place only if the party is in the city square. It will occur only once on any one night. Reroll if otherwise.

A caravan is surrounded by a horde of screaming people. The caravaneers are

fighting desperately against the mob, but they are losing ground. A gigantic fighter, standing near the lead camel is fighting four other men and is holding them at bay. A spear, thrown by an unseen antagonist, strikes him in the shoulder; he turns toward the assault. Someone stabs with a sword, the blow striking the giant in the back. He stumbles and, before he can recover, is swept under by the mob. The last camel in line is down and thrashing out with his hooves as the mob swirls over him like the rising tide covering a reef.

If the party intervenes, they will become targets for attack by 6d6 of the ghostly mob. If the party remains on the sidelines, 1-3 of the mob will see them and attack. The party withdraws, they may watch the destruction of the last caravan to leave Medinat Muskawoon.

Ghostly Mob: AC 6; MV 9"; HD 4; hp 15; #AT 1; D 1d4; SA nil; SD silver or magic weapons to hit; AL LE.

1. Limestone Causeway

The causeway that leads northwest through the blasted and rugged hills surrounding the city ruins is made of white limestone. Its top is perfectly smooth and flat, a perfect roadway no narrower than 20 feet wide.

2. Riddle Obelisk

An obelisk stands tall in the center of the northern city square. Its base is 25 feet square, and its height is well over 100 feet. The slanting walls are polished and reflective, save at the base, wherein are etched inscriptions in the ancient alphabet. The inscription on the east and west sides is long, probably of several sentences. That on the north and south sides is but a few words, and beneath it is a fist-sized indentation.

The inscription on the east and west sides is the riddle that the players must solve if they are to obtain the Star of Melos-Pelar. It is reproduced as Inscription 13-A on the reverse of the DM's fold-up map, and is translated as follows:

Star is hidden from sunlight by the Sun.
Four tests must ye pass before it shines forth.
To hunt treasure ye must treasure hunt.
From the gods, their gifts seek.
Cleanliness is next to godliness.
When ye have a friend's tears, the fiery gift,
and the hawk's wings, carry ye the four-

teen golden links to bridge the swamp.
Only then can mortals hear the chimes
and then may the Star light the way.

The shorter inscription on the north and south walls is reproduced as Inscription 13-B on the reverse of the DM's fold-up map. It reads as follows:

In its appointed time shall man arise
from his ignorance and, reaching for the
stars, offer them in wisdom.

Once the Star of Melos-Pelar is obtained from the Temple of Ra, the obelisk will chime, continuing to do so until this occurs. If any other Star Gem is placed in the hole, the east-and-west-face inscriptions will begin to glow. If, after the Star of Melos-Pelar is found, another Star Gem is placed in the indentation, the chime will be somewhat muted, but will continue nevertheless. If the Star of Melos-Pelar is placed in the hollow place under the writing, read the boxed description below.

In a soft, though commandingly penetrating voice, the obelisk begins to speak aloud, saying:

"The Sphere of Power retrieve:
This then is destiny's decree.
Doom and death with no reprieve:
This is the ancient prophecy.
Go ye to his mighty tomb
Where sky meets shore and sky again,
There sound the note, dispel the gloom,
And bring the light to entrance gain."

The Star Gem that was placed in the hollow flares into sudden brilliance, lit from within. The voice continues:

"The gem before you takes the power
To light the way toward Martek's tower,
Where, if survive those here assembled,
All shall see their finest hour."

And the Star Gem, its light extinguished, falls onto the square.

From this point on, that gem will glow with soft white light when held in the hand. If the hand holding the gem is pointed in the direction of the Pillar of Martek (Map 6-1, area 25), it will flare up with a brilliant white light.

3 and 4. The Narrows and Glass Lake

Between the high, tortured hills to the northeast probes a glittering tongue of glass. To the very shores of this tongue the rugged rocky slopes press in. Straight as an arrow it runs to the sea of glass beyond.

The mile-long mirrored lake is nearly

half a mile wide at its southern end. It stretches from the pavement to the southwest to The Narrows in the northeast.

Braided marks parallel to the shore scar the otherwise smooth surface of The Narrows, connecting to similar swirls scratched in the smooth surface of the glass lake in the center of the city.

5. Wooden Stakes

Around the shoreline of the glass-surfaced lake in the city's center are numerous stakes driven into the sand. Some of the stakes are old and weathered; others are quite new.

6. The Squares and the Esplanade

Paved with large white stone blocks, perhaps the same stone as the white causeway to the northwest, a public square lies on the north side of the glass lake, a tall grey obelisk in its center. It is flanked by the ruins of two graceful, once-three-story buildings, apparently the largest in the city. Now the graceful arches connect only broken walls, the once gleaming domes fallen to rubble in the shifting sands.

South of the glass lake, and connected to the northern square by the paved esplanade, lies another square. The three large buildings flanking it are now piles of rotten brick and sand-blasted stone.

7. 8. Ruins

The ruined Government Building (area 7) of Medinat Muskawoon lies to the west and north of the square, and the Pasha's Palace (area 8) lies to the north and east. Between them runs the Limestone Causeway (area 1). Before them, and towering over the ruins, stands the obelisk.

9. Temple of Horus

Gleaming red-brown in the sunlight (dark grey if approached at night), can be seen the mighty pillars of a temple. The unadorned, 40-foot-tall pillars form a square around an open court in which can be seen the statue of a giant man seated in an immense stone chair. The pillars are topped by large capstones that span the gap between each of them.

The statue's head is in the form of a falcon's, and the crown he wears is double-tiered. The chair and the figure are cut from

a solid piece of red-brown stone, there being no joint where figure and chair meet. The falcon head and the crown, however, are of jet black stone. The eyes of the falcon are of gems that sparkle and glint in the light. The right eye is a brilliant, yellow citrine, whereas the left eye is a milky-white moonstone.

The statue is that of Horus, and this is a shrine to the man-falcon of legend. His followers were many and mighty, for the falcon was a common bird of the area. Worshipers admired the strength, stamina, cunning, and intelligence of the animal, and carried its symbol into battle as their standard. There were many among the worshipers who felt that Horus was the oldest god in their pantheon. So strong was their cult that if a falcon were seen to alight, a shrine (many quite small) would be built on that spot. Worshipers of Horus wished to acquire the attributes of the falcon, and legends say that a sufficient supplication and offering to the god would give a man the ability to fly.

A *detect magic* cast upon the statue will reveal that there is magic in this place. The magic is quite ancient and powerful, but it feels dormant. Martek enchanted the eyestones long ago so that they would give the power of flight to anyone who held the gems to the eyes.

It is possible to climb into the lap of the sitting man and reach the eyes of the statue. The sockets are worn around the gems and there is enough space between the stone and the gems to insert a dagger or small pick with which to pry them out. Nevertheless, no matter how much force is applied, the eyes will not come from the head of the statue.

If, however, a PC stands before the statue, addresses Horus by name, and tells him of the need for his aid in recovering the gem imprisoned in the temple of Ra, the statue will respond. The eyes will roll from their sockets, falling to the ground and shattering in front of the statue, regardless of any attempts made to stop them from doing so. Each gem will break into as many pieces as there are members of the party. In this way, each member can have one piece of each eye.

As the PCs hold the gem fragments, they will have a feeling of flight. In order to fly, they need only invoke the magic of Horus. The fragments will leap to the eyes of the PCs, and they will know instinctively that they may fly, but only once. As soon as the magic has been invoked any step that the PC makes will cause him to take flight. When he alights, the gem fragments will fall from his eyes, and he will be able to fly no more. Thus, those who use the magic here will not be able to use the magic to counter the lotus blossom gas in the Temple of Ra.

10. Temple of Prometheus

Brilliant white against the light, a columned temple stands amid the surrounding desolation. Twenty slim columns support a low, pitched roof 30 feet above a simple platform. The main floor is gained by climbing four deep steps on the north, south, and west sides. A 20-foot-wide central aisle runs east and west, the eastern end completely closed by a wall pierced in the center by a single, 12-inch-diameter window six feet above the floor. A simple iron brazier stands in the central aisle towards the rear of the building.

This is a shrine to the Titan Prometheus, who was allowed to become a member of the Olympian pantheon after he had successfully challenged Zeus. It was Prometheus who allowed man to have fire, and for this he was condemned to have his liver torn from his body every day, only to have it re-grow at night. For his beneficence toward mankind, Prometheus is honored as the father of all arts and science. There were several temples to Prometheus in the fertile valley of the River Athis, brought here by the travelers from other realms far removed from this sphere. Prometheus is seldom depicted in any of his temples. Instead, the altar and symbol of the titan usually takes the shape of a brazier from which springs an eternal fire.

This temple is due east of the Great Hall of the pasha. It faces west and slightly south, its back toward the rising sun. It stands this way in remembrance that each morning during his captivity, the griffon-vulture would return to devour his liver.

Though it is not lit by any flame that can be seen, the brazier does have an eternal flame associated with Prometheus. A magical flame may be kindled here that will help the PCs defeat the asps in the Temple of Ra. It will just take some work.

A careful examination of the window will reveal that a piece of glass of some kind was once attached to it, fragments of which still remain. Actually, it was a lens that caught the rays of the morning sun in such a way as to direct them onto the brazier. This concentrated light was used to kindle the fire placed there before morning. The party can use the same method. If they do not have a lens big enough to fill the opening, they can chip a piece of approximate size from the sea of glass near by. By placing the glass in the window, and putting flammable material in the brazier, the sun's rays will ignite the fire. From this fire can be lit torches that will not burn out as long as the PCs remain in Medinat Muskawoon. They alone will have the ability to drive away the asps in the Temple of Ra.

A second way to gain the fire of Prometheus

is to kindle a fire in the brazier by other normal or magical means. Torches ignited from this fire will burn normally; though they will have none of the magical properties of torches kindled using the sun's rays, they still may be used to drive the asps away.

11, 21, 22, 24. Ruined Temples

These were some of the temples to the gods of various pantheons, as shown in the table below. Nothing remains of these temples save the rubble, though a cleric or worshiper of the various religions could identify the god worshipped.

Area	Pantheon	God
11	Greek	Tyche, Goddess of Good Fortune
21	Celtic	Dunatis, God of Mountains And Peaks
22	Finnish	Untamo, God of Sleep And Dreams
24	Egyptian	Osiris, God of Nature And The Dead

12. Baths of Kordek

This angular building rises from the surrounding desolation. Its blunt, cross-like shape plan is obvious even from a distance, and the ceramic dome that tops the building forms a point of reference for the southeastern corner of the ruined city.

The building was obviously designed by an architect who sought permanence and ease of construction over beauty. The exterior is simple and rugged with no attempt to smooth the line of the building or to please the eye. The northwest and southeast sides are opened with broad, squat arches that speak of simplicity and strength with no hint of grace and beauty found in the other ruins.

These baths are the newest of the three baths remaining in the city. Built over a sulfurous spring that had gone unused for centuries, the Baths of Kordek became a popular recreational spot for the wealthy caravan owners who lived nearby. It was the only bath to allow women on the premises, although they were segregated, accounting for the mirror-image interior.

The building itself is split down the center by a dividing wall. In plan, each side of the building is a mirror image of the other so the description of one side will do as well for the other. Only one side is described, and the DM should alter the description as necessary for the other.

Four, broad steps lead upward from the surrounding land. The shallow arch through which they pass is as broad as it is tall and opens into a dimly lit hall beyond.

Within, the wide hall is covered by a coffered dome that has alternate coffers removed to provide light for the room below. The walls and dome are covered with a thin layer of yellow powder. The floor surrounding the central pool shows the remnants of the inlaid mosaic with which it was once covered.

A double step leads downward into the wide, semi-circular pool that dominates the entire room. The pool is shallow on the sides, becoming deeper toward the center. Openings in the central pillar at the bottom of the pool lead to a 12-foot-diameter pipe from beneath the ground. Drains to either side of this, and blocked off from it by solid walls, stand at the bottom of 5-foot-square grated openings. Slotted caps over these drains gleam of gold through a film of yellow powder.

The drain caps prevent items in the pool from being sucked down the drain and into the sewers of the city. They are each 18 inches long, 8 inches wide, and 1 inch thick. Of solid gold, coated by sulfur powder from the water, they are strangely shaped, with a Z-shaped tongue at each end. When held side by side, it will be apparent that the tongues of one fit the slots of the other, and that they can be thus linked together. They weigh about 35 pounds.

These are two of the links enchanted by Martek to form the 14-link bridge over the void in the Temple of Ra. Others will be found in the various public baths in the city. When all have been gathered, one will disappear, as in the legend of Isis.

13, 16, 19. Landmark Ruins

These are the ruins of the city's largest landmarks, aside from the Government Building and the Palace. Their use is detailed below, along with the style of architecture and the stone used in construction. The Baths and the Collegium, though in ruins, have encounters and are described further.

Area	Use	Style	Stone
13	Caravansarai	Arabic	Brick
16	Baths	Roman	Pink Granite
18	Collegium	Greek	Black Marble
19	Hippodrome	Roman	Sandstone

14. Palaestra

The grey-pink stone used in the construction of this large building glows in the light.

The building's east and west walls are 170 feet long. They are carved to form very attractive frescoes of young men involved in various games and gymnastic activities. The north and south walls are similarly carved, but each has two arched entrances. Even the dark arch-ways of the facade are inviting. The building is covered by a peaked, clay-tile roof, longer on the south end than on the north; that there must be an open court is apparent.

Within, the open, peristyle court is dominated by the open area and colonnade. On the north side are three enclosures. Wall paintings of various athletic events decorate the white marble facades. On the other three sides, small alcoves are set into the outside walls. Inside the open area is a large pool, now with sand, dust, and some of the clay tiles that once protected the roof. The surface of the sand is scalloped and littered with debris.

The Palaestra was a colonnaded area that provided space for general lounging, reading, and athletics. Centipedes now inhabit the pool debris, and they will attack if disturbed. The scalloped surface of the sand is an indication of their presence. These centipedes, larger than the normal giant centipedes, will attack as soon as the dust in which they live is disturbed. They will continue to attack until they are killed, their enemies are dead, or the intruders flee. Up to six may attack a single target simultaneously, biting with their mandibles and injecting a weak poison into the victim. The poison does 1d4 points of damage for three rounds after a successful attack. Victims who successfully save vs. poison at a bonus of -2 to the die roll take half damage.

It will take four men an hour to dig through the debris to find the drain and slotted drain caps located in the center of the three arms of the pool. The drain caps prevented items in the pool from being sucked down the drains and into the sewers of the city. They are each 18 inches long, 8 inches wide, and 1 inch thick. Of solid gold, lightly coated in places by lime from the water, they are strangely shaped, with a Z-shaped tongue at each end. When held side by side, it will be apparent that the tongues of one fit the slots of the other, and that they can be thus linked together. They weigh about 35 pounds.

These are three of the links enchanted by Martek to form the 14-link bridge over the void in the Temple of Ra. Others will be found in the various public baths in the city. When all have been gathered, one will disappear, as in the legend of Isis.

6d6 Centipedes: AC 9; MV 15"; HD 1; hp 6; #AT 1; D 1-2; SA poison; AL N.

15. Baths of Persepolis

A low, grey, stone building, surrounded by the ruins of the southern portion of the city, rises imperceptibly from the surrounding desolation. The low, red tile roof blends with the dull hills in the distance. A single door pierces the northeast wall.

Within, a wide, open hall is covered by an open roof slanting toward the outer walls. It is supported by 16 simple columns, forming a central court. Contrasting with the dull exterior of the building, the interior is paved and lined with gleaming white marble. The brilliance of the interior reflects the light that streams through the central opening relieving the gloom associated with so many buildings of this doomed city. In each of the far corners can be seen the depression of a pool, another almost filling the central court.

Shallow on the arms that extend into the hall, the outside pools grow deepest at the wall corners. The pools are made of the same white stone as the rest of the building and reflect the available light. The floors of the pools are filled with dust and sand, probably blown in by the wind.

The 40-foot-square central court contains a 20-foot-square pool almost completely filled with debris. Each of the three corners pointing toward the outer pools has an opening through which water must have come in the past.

The Baths of Persepolis was one of the first bathhouses built in the city, and reflects the simple architecture of the period. This building is the least presumptuous of the surviving buildings, and nestled among the ruins of the southern sector of the city could easily be missed in a casual examination of the city.

An examination of the pools will show the entry spout for the water in the corner toward the central court. The drain is in the opposite corner of the pool set into the corner of the wall. The central pool, which will take some time to clear, has its drain in the center.

Each drain has a slotted cap to prevent items in the pool from being sucked down the drain and into the sewers of the city. They are each 18 inches long, 8 inches wide, and 1 inch thick. Of solid gold, coated lightly by lime from the water, they are strangely shaped, with a Z-shaped tongue at each end. When held side by side, it will be apparent that the tongues of one fit the slots of the other, and that they can be thus linked together. They weigh about 35 pounds.

These are four of the links enchanted by Martek to form the 14-link bridge over the void in the Temple of Ra. Others will be found in the various public baths in the city. When all have been gathered, one will disappear, as in the legend of Isis.

16. Ruined Baths

Standing in ruins along the esplanade, lies a building that once was an enormous public bath. Fully five vaulted roofs held aloft by simple columns covered the many pools below. Now, all that remains is one, covering a large circular pool near the northern end, where four enormous pillars still hold up the roof. A body lies near the pool clutching a golden object in his hand.

The body is that of an adventurer who sought the 14 slotted golden drain caps Martek placed in the baths. He was caught by the three wraiths that inhabit the area. Before the PCs can investigate either the body or the treasure it holds, they will have to deal with the wraiths.

Once they have been disposed of, the body may be examined. The victim was cleaning the lime deposit from the slotted drain cap in his hands when he was struck and killed; in his backpack, along with tools of his thieving profession, is one already cleaned. At his side is a *dagger +1*; in his purse are 30 pp, 12 gp, and a gem worth 500 gp.

The pool bottom has been cleared of sand and debris, revealing two drains, minus the slotted drain caps that prevent items in the pool from being sucked down the drain and into the sewers of the city. The caps are each 18 inches long, 8 inches wide, and 1 inch thick. Of solid gold, they are strangely shaped, with a Z-shaped tongue at each end. When held side by side, it will be apparent that the tongues of one fit the slots of the other, and that they can be thus linked together. They weigh about 35 pounds.

These are two of the links enchanted by Martek to form the 14-link bridge over the void in the Temple of Ra. Others will be found in the various public baths in the city. When all have been gathered, one will disappear, as in the legend of Isis.

3 Wraiths: AC 4; MV 12"/24"; HD 5+3; hp 21,30,25; #AT 1; D 1d6; SA energy drain; SD magic or silver weapons needed to hit; AL LE.

17. Temple of Ra

For adventure in this area, use Map 13-3 and the Temple of Ra Encounter Area descriptions that follow this section.

18. Collegium Ruins

An imposing facade of black stone abuts the esplanade halfway between the two city squares. Its huge columns and archways stare out over the glass lake. A broad, central doorway is formed by a gigantic arch,

40 feet broad at the base and 60 feet tall at the apex. This black mouth gapes at any who would dare enter.

The back half of this building lies in ruins, only parts of the gilded domes remaining. High walls dominate the standing end, pierced by tall windows. A high vaulted roof partly covers the area, shrouding the ruins in gloom, and shafts of sunlight fall blaze like beacons.

At the base of an outside wall, slate has been attached, extending from the floor to as high as a man can reach. Light streams onto a spot before it, and a swirl of dust, the size of a man, dances in the light.

This is the ruins of the Collegium, once considered to be one of the finest schools in all of the Forgotten Realms. The time, effort, and treasure lavished upon it lie in ruins, and the scholars that once filled its rooms and halls now lie dead. The only inhabitant is a dust spectre, the spirit of one of the aged scholars that once lectured here. The players may choose to interact with the monster or by-pass the encounter completely.

Characters who stare at the swirling dust will be able to discern the form of a man in robes, his arm raised as if to make a point. Any who enter the ruins for a closer look must save vs. charm or become mesmerized by the lecture and fall into a deep sleep, remaining so until some unaffected party member drags them from the ruins. Those who pass their saving throw will be able to hear the pedagogue lecturing about the meter in poetry ascribed to an ancient language; it is very dull.

But the pedagogue can be interrupted. A party member who can hear him may ask one question concerning the city of Medinat Muska-woon, its history, or the current situation. Although testy about being interrupted, the pedagogue will answer to the best of his ability. If the same player asks a second question, the dust specter will become angry and proceed to revile the questioner.

The Dust Specter may be destroyed by attacking with blunt weapons (as he is dull, only dull weapons can damage him), by casting *dispel magic* at him, or by fanning the air about him. Weapon and magical attacks are done normally. Fanning the air will cause the dust to disperse and the apparition to vanish. If attacked, he will return the favor, each touch aging the victim 10 years.

Dust Specter: AC 0; MV 4"; HD 13; hp 15; #AT nil; D nil; SA Charm; SD blunt weapons needed to hit; AL LN.

20. Temple of Balder

The following boxed description describes this area from a point outside the outer ring on the

esplanade. Read the second boxed description when the PCs enter the temple.

Almost due east of the glass lake and touching the esplanade, stands a low, curving hill about 400 feet across. Beyond the mound, the tops of a number of stone objects can be seen. Three openings lead through the mound, which forms a ring 20 feet high. A space of 30 feet separates this ring from a second mound, which forms an inner ring also 20 feet high. A single opening leads through the inner ring, and that is aligned so that a passageway leads from the esplanade through both rings.

Just within the inner ring, flanking the entry path, are two immense grey stones that tower over the inner yard. These stones, which are 10 feet on a side and stand 40 feet tall, are part of a circle of smaller stones, the tops of which can be seen behind the mound. Aligned with the entry passage, a stone shrine can be seen through the entry stones.

The gigantic stones, grey and brooding, stand as sentinels on either side of the entry. To the right and left, 24 smaller stones, only half the size of the larger ones, curve away in a great circle. A ring of man-sized stones, about 50 in all, surround a shrine nearly at the center of this area. Behind the shrine to the west, an even smaller circle of stones may be seen.

The shrine is a circular slab of multi-hued stone raised two feet above the level of the ground. It is backed by a semicircular wall of similar stone that rises 15 feet above the floor. The wall is carved in a twisted lattice work that appears to have no end or beginning. Centered and protected by the arms of the semi-circle stands a black marble column, 2 feet in diameter and 10 feet tall; its surface has been carved into a fabric design with many twisted and woven threads.

Behind the raised shrine stand 13 grey, weathered stones, 5 feet wide, 3 feet thick, and 15 feet tall. They form an irregular circle around a stone tablet that rises 5 feet above the ground. The tablet is of black rock, smoothed and polished to a high shine.

Balder was the most popular of all the Norse Pantheon. The other gods were charmed by his good looks and easy personality, and he was a sought-after companion on all of their adventures. But Balder was troubled by dreams of his own death. When he confided those fears to Odin's wife, Frigg, she was so worried that harm might befall Balder that she made each item on earth swear that it would not injure

him. Once this oath had been accepted, the other gods would amuse themselves by hurling various objects at Balder. Angered by the attention paid to Balder, the malicious Loki went in disguise to Frigg and asked her about the oath. She finally confessed that all the plants, animals, stones, and metals of the Earth had taken the oath save one, the lowly mistletoe. Loki fashioned a wand of mistletoe, and giving it to the blind god Hod, directed him to hurl it in the direction of Balder. Hod did, and the wand struck and killed Balder.

This temple is dedicated to Balder and those who are the charming friend to all. To protect Balder from those who mean him harm, a shrine to the Norns, the Fates, stands before the circle of stones that are dedicated to Balder himself.

The Norns, also called the Fates, hold the threads of life and destiny. They know the fate of each mortal, and they stand here to protect the fate of the beloved Balder whose temple lies beyond. If a PC stands within the semi-circular wall, facing the wall and with his back to the column, there is a chance that the Norns will commune with him. There is a 2% chance for each point of INT possessed by the PC. Fighters add STR to that percentage. For those who pray to a member of the Norse pantheon, the chance of communication is doubled.

If communication takes place, the Norns, appearing as ancient women, completely hooded, will appear in front of the PC, turning to address him. They will ask him three questions:

"What is your family?"
"What do you seek in this city?"
"What do you wish from us?"

The questions should be answered quickly, truthfully, and without consultation with the other members of the party. Each player may make contact with the Norns but once.

To the first question, the character is expected to answer "I am (his name) of the house of (family name) of the land of (country name)." Should this not occur, the Norns will prompt for such an answer. They know the future, and the past, and thus will detect and revile any falsehood, terminating the interview at once.

To the second question, the character is expected to state that he seeks the gem. The third question should be in the form of a request for information, which is all the Norns may provide. If information about the mission is asked, the answer should be as short and truthful as the DM can make it.

The circle of stones consecrated to Balder may give off a strong sense that it is warded magically, which it is. Those passing between the stones into the center of the circle should make a save vs. charm to feel that magic when they break through the circle. Those failing

their roll will not feel it. Spell casters and clerics of the Norse pantheon will feel it automatically.

The ward is designed to keep wooden objects, especially mistletoe, away from the shrine. As the character passes through the circle, those who failed the roll will cast away any wooden implement they have, letting it fall to the ground outside the circle. No damage will be done to the items, and they may be retrieved when the character passes outside the circle.

Once all the party members who are willing to pass the circle of stones are within, those inside will see a handsome man wearing a simple tunic, trousers, and boots seated on the black stone tablet. He will stand, face the assembled party, and address them, saying:

"Behold the unlucky Balder, friend to all he knows. Those of you who would weep for him, hold forth your hand."

Those party members who hold out their hands (a slow five-count by the DM should be long enough for them to decide) will find an amber tear-drop deposited in their palms by the figure just before he vanishes. The amber tear-drop is a charm that will allow the holder to safely pass the Eye of Hathor that guards the entrance to the Temple of Ra.

23. Baths of Drusus

This building, 200 feet long and 120 feet wide, is made of greenish stone. The north-east end is covered by a vaulted roof supported 60 feet from the floor by immense stone columns. The remainder of the building is open. Between the pair of columns on the northwest and southeast walls are windows that begin 20 feet from the floor and rise to the top of the arch 40 feet away. Two archways open in the center of the northeast wall, and four open in the southwest wall.

The roofed northeastern area is split into two parts, a windowed wall spanning the pillars between them. In the approximate center of the 100-foot by 60-foot room is a 30-foot by 20-foot pool of polished white stone. Dust has filtered in through the open window and door, lightly covering the floor and the pool bottom, which slopes toward the center.

A long pool fills most of the southwestern open area, which likely was once paved with grass. The far ends are quite shallow, and the floor slopes down gently toward the center portion, which is filled with dust, sand, and debris. The walls and exposed bottom of the pool are made of highly polished white stones set into mortar.

A pair of wraiths inhabit the roofed area, hiding in the shadows at the top of the vault. If encountered in the daytime, they will be in the northernmost room. If encountered at night, they may be anywhere in the bath. They will attack together, as though comrades-at-arms, which they were in life.

A search of the central portion of each pool will quickly reveal the drains and slotted drain caps. The drain caps prevent items in the pool from being sucked down the drain and into the sewers of the city. They are each 18 inches long, 8 inches wide, and 1 inch thick, of solid gold, coated lightly with lime from the water. They are strangely shaped, with a Z-shaped tongue at each end. When held side by side, it will be apparent that the tongues of one fit the slots of the other, and that they can be thus linked together. They weigh about 35 pounds.

These are four of the links enchanted by Martek to form the 14-link bridge over the void in the Temple of Ra. Others will be found in the various public baths in the city. When all have been gathered, one will disappear, as in the legend of Isis.

2 Wraiths: AC 4; MV 12"/24"; HD 5+3; hp 21,30; #AT 1; D 1d6; SA energy drain; SD magic or silver weapons needed to hit; AL LE.

Temple of Ra Encounter Areas

For play in this area, refer to Map 13-3 in the *Map Booklet*. This Encounter Area corresponds to Cursed City of Stone area 17 on Map 13-2.

Ra was chief among the Egyptian pantheon and believed to be the creator of the universe. When, in his old age, he found that man was plotting against him, he invoked the eye of Hathor to massacre mankind. Finally appeased, he decided to quit the earth. From then on his travels by boat across the sky have governed the movements and life of man. This temple to Ra contains many of the aspects of his legend.

1. Eyes of Hathor

Two great pylons of red stone stand out amidst the ruins that surround them. On each of the stone pylons that forms the gate-way to this temple are inscribed gigantic human eyes that stare outward. Unlike any other building or ruin in this cursed city, this temple has a band of clear ground around it as though nothing can approach it.

As the opening between the pylons is inspected, the eyes seem to look within the soul, searching for reason to be destructive. Within the gate can be seen a wall topped with pillars and a room beyond.

As the party approaches the temple, they will have to deal with the Eyes of Hathor, enchanted by Martek to repel any who seek the Star Gem he left inside. The Eyes can read minds, and will know if those who approach know the gem is inside and desire to get it. If the PCs do not yet know that the temple holds the gem, the Eyes will know this too.

This mind probing is not at all subtle, and was not meant to be. Be sure that the players know it is occurring, though just what the Eyes search for should not be stated directly. If the PCs do not know the Star Gem is inside, the Eyes will revert immediately to carvings, any threat they may have inspired gone. If the PCs do believe that the Star Gem is inside because they have figured out the Obelisk's riddle, then there is very real danger, and the way the Eyes continue to peer at the approaching party should give the players warning of this danger.

When a member of the party reaches 60 feet from the pylons, the Eyes will begin to glow. Each party member must save vs. charm or become transfixed and motionless. For each 10 feet the PC moves toward the Eyes, the save must be rerolled, decreasing the chance to save by one for each subsequent roll. Once transfixed, the PC may not move. If there is no one who can reach him to drag him beyond the 60-foot mark, he will eventually die.

The Eyes of Hathor can be defeated in a number of ways. The party members can approach the gate-way backward. There is a chance that they will stumble (each makes a Dexterity check) and see the Eyes, but they should be successful in this approach. They could attack the eyes with missiles and magic from outside the 60-foot range. Eventually the eyes will be destroyed by this kind of attack. The party also may scale the walls behind the eyes. If they do this, they will have to deal with the snakes from the Courtyard (area 2) as soon as the first one touches the roof of the colonnade. The power of flight from the Temple of Horus (City Ruins area 9) will carry a PC over the wall out of sight of the Eyes.

The best way is to seek to charm the eyes by using the tokens given at the Temple of Balder(20). If the amber tears are displayed to the Eyes, they will glaze over and allow the PC and one other holding his free hand to pass.

Eyes of Hathor: AC 0; MV Nil; HD 10+10; hp 70; #AT Nil; D Special; SA magic charm and damage; AL LN.

2. Courtyard

A ten-foot wide colonnade supported by pillars surrounds the courtyard of the temple. Each pillar is topped by a blossom with many petals. The sand within the court is obviously wind-blown, for twisting and

curling tracks upon it are probably due to the ceaselessly shifting wind.

The far wall of the court is topped by columns much larger than those supporting the colonnade. In its center, a wide portico opens into a darkened room beyond. The columns hold up the temple roof.

The closed blossoms at the top of the pillars are the lotus blossoms, which legends say have a fragrance that brings forgetfulness and eventually death. Though this is not important in the play of this area, the DM should determine if any PC knows this legend, for it will become important as soon as this area is crossed.

To cross this court, the PCs will have to deal with the poisonous asps who live here. As soon as the first PC touches the roof of the colonnade or sets foot in the courtyard, a host of snakes begin to fall from the pillars that surround the court.

The snakes will first move to block entry to the Lotus Gate (area 3) and then move to attack the party. A maximum of three snakes may attack any party member at any one time. Although their bite is not dangerous, their poison is quite deadly; a normal save vs. poison is applicable. The snakes will continue to attack until there are no living members of the party in the Inner Court. There are more snakes than the party members can kill, and they keep emerging from the pillars for as long as any living member of the party remains in the court. The snakes disappear on death, and once there are no living PCs in the court, all the snakes will disappear at once.

Ordinary magic will not work here, but the power of flight obtained from the Temple of Horus (City Ruins area 9) will. Otherwise, in order to pass the snakes, the party can take its chances in fighting them, moving across the courtyard or the colonnade as quickly as possible. A better way is to carry torches lighted at the brazier found in the Temple of Prometheus (City Ruins area 10). These torches, whether ignited normally or by the magical means, are enough to keep the asps at bay when waved in their general direction.

Asps: AC 5; MV 12"; HD 4+2; hp 17; #AT 1; D 1-3; SA poison; AL N.

3. Lotus Gate

The lintel of this gate-way is of the same highly polished green stone as the pillars. It contrasts with the pink stone of the 10-foot-high wall and the black stone of the realistic carved flower blossoms that crown each 15-foot pillar. Beyond the portal lies the darkness of the temple interior.

The snakes will not attack any PC standing beneath the Lotus Gate. From this position, the party may inspect the interior of the Hall. A PC using the power of flight from the Temple of Horus (City Ruins area 9) may pass through this gate and circle the area beyond; alternatively, he may choose to alight here with no difficulty.

4. Entry Hall

The broad expanse of the entry hall is cool and dark compared to the blazing light of the inner court. As the eyes become accustomed to the darkness, it is possible to see that the room is 60 feet wide and 30 feet deep, with a 10-foot-wide portal in the center of the far wall. It is just possible to make out the faint odor of a heavy floral perfume.

As soon as the first PC sets foot on the floor of the Entry Hall, the lotus blossoms atop the columns will open and release their perfume. True to legend, this magical gas will cause the PCs to forget why they are in this place. Those in the room must save vs. charm or forget they are adults, and begin to play like children. A new save must be made each round, with PCs already charmed making the roll at a penalty of -1. Any who fail begin or continue to play.

Charmed PCs will play in the Entry Hall, romping at hide-and-seek, tag, fox-and-geese, red rover, and so forth. An unaffected PC may break the charm if he slaps an affected PC very hard (1-2 damage points) in the face.

There is a 5% cumulative chance per round of an affected PC leaving the Hall for the sunlight of the Courtyard. If play begins in the Courtyard, the PC will encounter the snakes there. The PC will continue to play there until he comes out of the spell, falls dead, or is removed forcibly. He will not feel any snake bites while charmed, though saves vs. poison may be made normally.

Ordinary magic cannot work here, and so there are only two ways to defeat this magical trap. Though a thief can climb the pillars and move across the room by himself, the party cannot follow. Even this is impossible once the trap has been sprung.

Once the magical gas has been released, the party can move across the hall very quickly, hoping to make their saving throws and gain the Inner Gate (area 5). There, just as the snakes could not attack beneath the Lotus Gate, the magical gas has no effect and the charm will break.

A safer way is to gain the power of flight from the Temple of Horus (City Ruins area 9). Holding the gemstones, the PC can call upon Horus to give him flight. The gemstones will fly up to his eyes of their own accord, lodging there but not impeding sight. His next step will

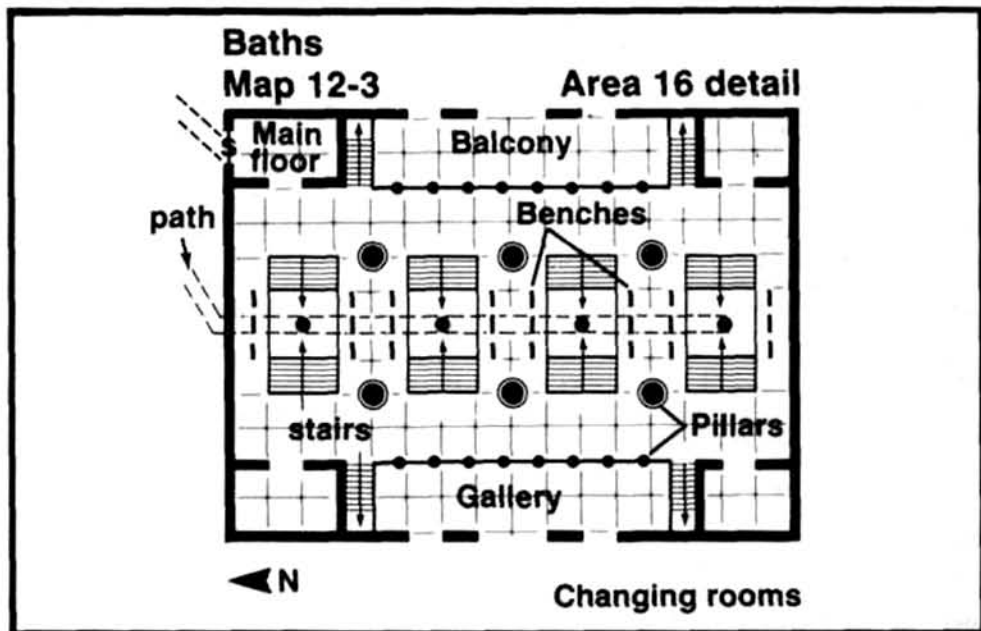

be in the air, flying until he decides to alight. He may fly anywhere in the temple, including through the Inner Gate (area 5) into the Deep Swamp (area 6) beyond. He may alight at the Inner Gate if he chooses.

5. Inner Gate

The marble that lines this 10-foot-wide by 20-foot-high door is coal black. Fully 5 feet thick, the wall it passes through joins imperceptibly with the darkness beyond.

While in the opening, neither in the Entry Hall nor in the inner room, the PCs are safe. The magical gas has no effect here, and the floor is solid. It is a place of refuge. A PC using the power of flight from the Temple of Horus may alight here with no danger of falling into the Deep Swamp (area 6).

6. Deep Swamp

The floor, solid and comforting beneath the inner gate, has become a bottomless void whose darkness swirls and undulates, coalesces and dissolves. A smell of decay and death, as from an ancient swamp, fills the chamber. Across the void can be seen the Sanctuary, wherein rests a fist-sized purple gem, glowing in the darkness.

In this area, Martek opened a gate to the Deep Swamp wherein Isis and Ra escaped to avoid the wrath of Set. Reaching into the darkness below will reveal no bottom. Throwing an object into the darkness will produce no sound. A PC who falls into this area will be

lost irrevocably.

No magic, save for that which Martek has provided, will work here. Torches from the Temple of Prometheus (City Ruins area 10) can illuminate the area. The power of flight from the Temple of Horus (City Ruins area 9) also will work here, but as it will not allow the PC to hover, a PC who flies into the area must alight on the Altar (area 7) or return back to the Inner Gate. Physical ways may be found to cross the 21-foot span between the Inner Gate and the Altar, but these would require saving throws, and any failure would result in irrevocable loss of the character.

To bridge the void, the party must use the golden drain caps from the pools in the city's public baths. These were altered by Martek to fit together into an interlinked bridge 8 inches wide and 21 feet long if all 14 links are used. As only 13 links can be together, the fourteenth disappearing, the bridge will be incomplete. Nevertheless, the bridge will span the gap... almost.

If the PCs link the pieces together (the order does not matter), they will be able to push the bridge out over the void. The bridge will not fall into the void, it being suspended by magic. Once the bridge is in place, a party member will be able to cross the bridge (carefully) and almost reach the Altar. The bridge is steady, but it is, after all, only 8 inches wide, and so a Dexterity check will be required. Apply modifiers to this save if the PC making the attempt is wearing armor or a hooded backpack, or carrying an awkward weapon. The idea is to give the player a moment or two of heart-clutching fear, and not to use this as an excuse to waste characters.

7. Altar of Ra

Floating in the void that surrounds it is the white marble altar upon which lies a huge gem, sparkling with inner light. The altar is 8 feet long, 2 feet wide, 4 feet deep. It has no visible support.

About the size of a clenched fist, the gem is a deep purple stone covered with tiny facets to form an irregular ball. Light pulses from within it, casting purple glimmers now and again.

The gem is the Star of Melos-Pelar, the fifth Star Gem of Martek, placed here by Martek himself. It is the treasure that brought the PCs into Medinat Muskawoon in the first place, and it was to protect this gem that the temple's guardians were created. Without this gem the PCs cannot gain entrance into the tomb of

Martek.

The bridge of gold that spans the void does not quite reach the altar and the gem. A player character who has reached the end of the altar can easily reach the stone cenotaph, even though he cannot reach the gem itself. All he need do is step off the bridge and climb onto the altar, from which safety he may grasp the stone. This will require a Dexterity check made at -2 for any character but a thief, who may use his *climb walls* chance if it is better.

If the PC lunges for the stone, there is a chance he will lose his footing before he grasps it. He must make a Dexterity check or begin to plummet into the void. A second Dexterity check will allow him one last chance to grasp the stone before falling into the abyss. Success in either of these saving throws means that the PC has grasped the stone.

A character choosing to use the power of flight from the Temple of Horus may fly over

the Deep Swamp and alight on the altar. This is *not* a safe refuge as were the Lotus Gate (area 3) and the Inner Gate (area 5). Unless the PC is used to flying in the DM's estimation, a Dexterity check will be required. Failure will mean that the PC has stumbled. A second, final Dexterity check will allow the PC to recover while still on the altar and avoiding the gem.

As soon as the stone is in the hands of a PC, all of Martek's guardians become inactive. The floor in the inner chamber becomes solid, and so a PC falling while holding the stone will strike the floor rather than fall to his death. Simultaneously, the Obelisk (City Ruins area 2) will begin to chime, and the PCs can hear it. It will continue to chime until they return to the obelisk and place the Star of Melos-Pelar in the indentation below the inscription on either the north or south walls.

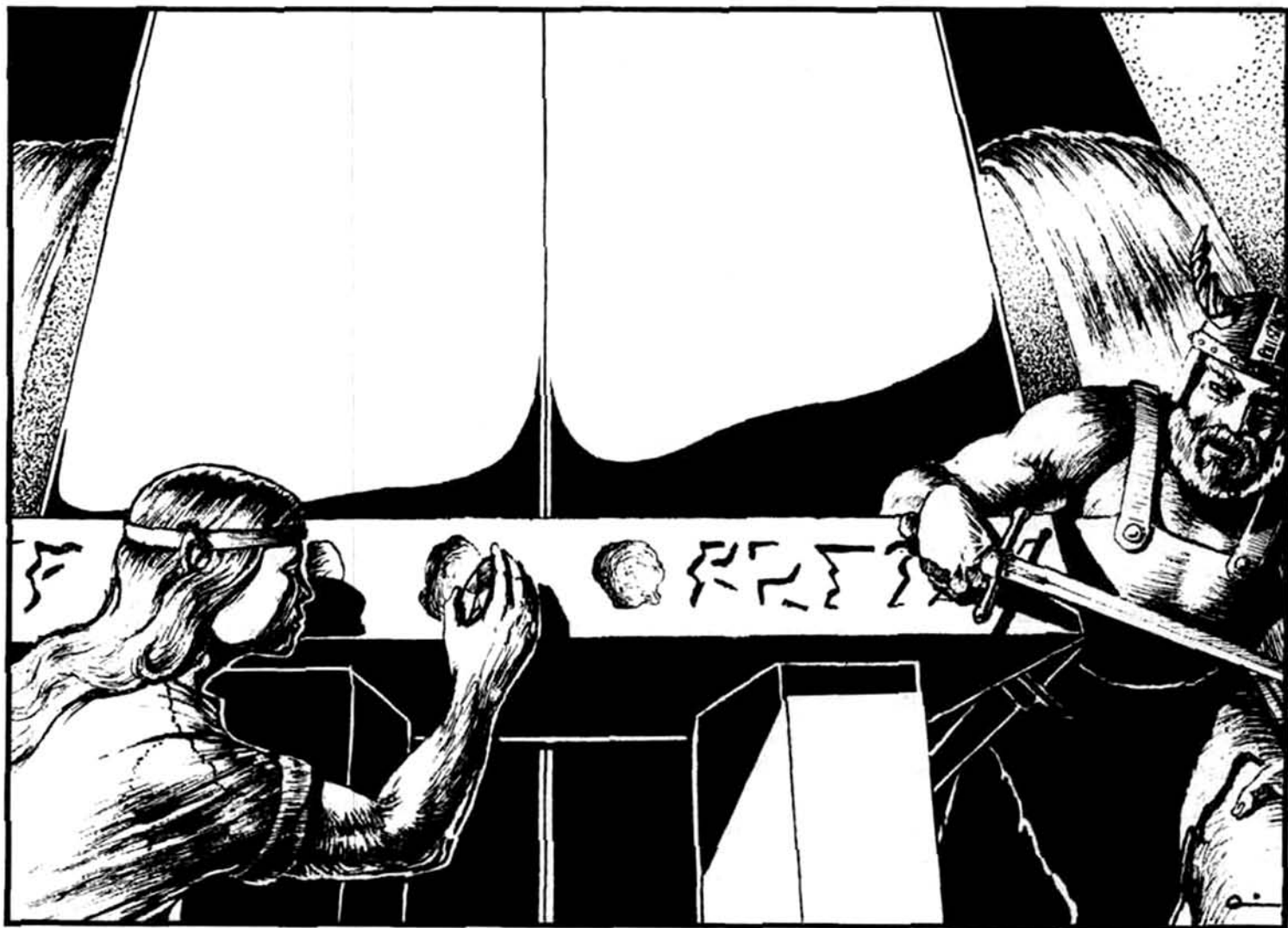

Chapter 14: Citadel of Martek

Background

Citadel of Martek

The Citadel of Martek has been hidden in the open for 1000 years, ever since Martek sealed himself away. It may be called down by striking the Pillars of Martek, which act like a gigantic tuning fork. They will emit a ringing note that will summon the Citadel. This has happened many times in the past millennium.

Between the pillars is a one-way teleport disk that leads to the Garden of the Cursed before the Grand Hall of the Crystal Prism. Without three Star Gems to open the doors to the Grand Hall, people who teleport into the Garden are trapped. There are two communities of trapped people there now, and four NPCs who have recently arrived.

Inside the Grand Hall of the Crystal Prism, protected by a fierce iron phoenix, is an elevator that descends into the Cathedral where a miniature crystal model of the Citadel stands. Martek had created this model as the teleport device into his Inner Sanctum, providing tests there from time to time while he lived to insure that his uninvited guests were at least worthy of his time. There are six minarets which must be placed in sockets within the model before teleportation to his Inner Sanctum is possible.

At the time of his final retreat, there were only two tests that had not been completed: the Black Abyss, in which distance, time, and magic all become distorted; and the Mobius Tower, in which a Guardian of time was taking a short vacation. Martek, weary from all of the magical preparations needs to prepare for his eventual resurrection, only added one more, the Desert and Crypt of Al-Alisk. Now, these three tests must be completed and the minarets retrieved before the Citadel model will teleport anyone into Martek's Inner Sanctum.

Martek's bones lie in state in his Inner Sanctum. His apartment has become his tomb. If the five Star Gems he hid are brought to this place, he can be returned to life. He will then act to banish the evil efreeth Khalitharius forever, and handsomely reward the heroes who completed his quest.

Garden of the Cursed

Through the centuries after Martek built this tomb, many people managed to get this far into the tomb. Without the Star Gems, they were trapped here in the garden. Most of the people living here have been in the garden all their lives and do not really believe that an outside world exists. Although they do not know everything, they do know a lot of useful information about Martek's tomb.

There are two groups of people in the Garden, guilders and the palan-teen. Guilders are the descendants of thieves who have become trapped here, and the palan-teen (called maddogs by the guilders) are the descendants of

paladins and good warriors who became trapped. There are not many of either group, and so inbreeding has made them of low intelligence.

Guilders

Because they are all thieves and have always been thieves, the average guilder has thieving abilities of a 12th level thief. Over the centuries, theft has evolved into a religion for the guilders. Now, they worship the "Master-guild" who they believe lives just past the doors to Grandal, the Grand Hall of the Crystal Prism.

This is the guilders' version of their history:

At the beginning of time, there were two peoples, the guilders and the maddogs. The maddogs were terrible and powerful in battle, slaying the holy guilders and preventing them from performing their sacred stealies. One day, the Master-guild told his people that they must travel to the world of Mar-Tik and work to be worthy of entering the Grandal. So now we live in the world of Mar-Tik at the very gates of Grandal. When the time comes, the gates shall be opened and we will fulfill our destiny. The greatest stealie of all eternity shall be completed, and the guilders will be admitted into the grace of the Master-guild.

It is easy to see that some of the words the guilders use have been corrupted from their real meaning. The name *guilder* comes from the word *guild*, as in *thieves' guild*. (The world of Mar-Tik comes from the name *Martek*. The *Masterguilder* was once the *guildmaster*. *Grandal* is a corruption of *grand hall*. A *stealie* is an act of theft. A *maddog* is one of the good warriors who call themselves the *Palan-teen*, from the word *paladin*.)

The guilders believe that Grandal is heaven, and when the doors are opened using the sacred names for the three great stars, they will be admitted into the presence of their god. The world to them is no larger than the Garden they are in, and they do not believe the outside world exists, becoming upset and confused by talk of places beyond the Garden.

Theft is considered to be a sacred act which will impress the Masterguilder and insure a guilder a place in Grandal. The more valuable the stolen item, and the more danger involved in the theft, the greater the glory resulting from the stealie. Guilders are not troubled by theft among themselves because they believe they will stealie their lost goods back anyway.

Less than one week before the PCs arrive, the wizard Trifakas and the thieves Pawnis and Sardok appeared. Before that time Villagemaster Bandik was master of the guilders. After he

arrived, Trifakas, through his intelligence and his magic tricks, convinced the guilders that he was an emissary from Grandal, and that Pawnis and Sardok are his assistants. Now Bandik and the other guilders are intensely loyal to the three charlatans, almost revering them. The guilders will remain loyal and blindly obedient until they are convinced that their new leaders have broken one of the sacred guild laws.

Palan-Teen (Maddogs)

Most of the original palan-teen came to Martek's tomb hoping to bring about the fulfillment of Martek's prophecies before their time. By doing so, these good warriors and paladins hoped to save many people. Now, they move with deer-like speed and grace, fighting as 10th level fighters. The guilder name for the palan-teen is maddogs; the palan-teen use many of the same words as the guilders.

This is the palan-teen version of their history:

When evil was brought into Mar-Tik, the great palan-teen Sedarik brought the palan-teen into the world above. The guilders' evil stealies of the glories of Grandal were then stopped by the palan-teen. We must always watch the guilders to stop their stealies. Someday the doors of Grandal will open and the guilders will flee from the glory of Grandal. The good will be released from Grandal and pour forth across the vast universe.

The paladin Percivilis the Pure arrived in the Garden three weeks ago. Of greater intelligence than most of the palan-teen leaders, and of good lawful alignment, he has assumed leadership of the palan-teen, who recognize him as being better than they are. His high charisma make him a good leader and spokesman for them, though there are several other leaders from before he arrived.

Black Abyss

The Black Abyss lies just beyond the Guardians of Time and Space, a gash that bridges the Prime Material Plane and the 666 layers of the Abyss. Distance, time, and magic all are affected, becoming distorted one after another. The farther one goes in the Black Abyss, the faster the Prime Material Plane breaks down, until it spirals into total confusion.

The only way to get to this place is via the Crystal Prism, and the only way to return from this place is to grasp the miniature crystal minaret.

Mobius Tower

This tower exists on its own unknown, closed plane. It has four levels connected together in a

magical loop that has neither a beginning nor an end. One of the stairways (area 7) connects all four levels. It is continuous in either direction, passing all four levels in order one after the other in both directions. The cycle is endless, like a Mobius Strip, and on this stairway it is possible to get from one level to any other by either climbing or descending. The other three stairways in the Tower connect only two levels each.

The 10-foot-thick walls that surround any level also are connected magically. The "outside" of a level's "north" wall is the "inside" of that level's "south" wall, and vice versa. A level's "east" and "west" walls are connected in a similar way.

One of the Guardians of time has made the Mobius Tower his home for a while, just as an amusement. Because of this, the Tower is time-trapped, and most of the people and things within it are in a different time-frame, and moving very slowly with respect to the PCs. A thousand years could pass before the PCs could see any of the people or things in the Tower move. These objects will seem to the PCs to be "frozen" in both time and space.

Desert and Crypt of Al-Alisk

This wilderness area has been the resting place of the Al-Alisk clan since the days of the pharaohs. The crypt was built in a cave in the hills of the Desert of Desolation. Within the crypt lies the beautiful Princess Sithal Al-Husn, daughter of the Sultan of Pazar. On the night of her wedding to Athas Al-Din in the city of Akhir, she was stolen by Habrauk Al-Nirin of the Al-Alisk clan, a man totally smitten by her beauty. To keep her beauty forever, her captor froze her in a magical crystal box in the most secret place within the crypt. Her spirit remains trapped there, even though she died thousands of years ago.

The deed did not go unpunished, for it started a blood feud that raged for 5 generations before the dying desert and the killing finally ended the blood-lines of both the Al-Alisk clan and those of Pazar and Akhir as well. Now, the battle is waged nightly as the spirit of her intended husband leads a host of spirit warriors, all those who died fighting the Al-Alisk legions, to battle. Nightly they are met by the spectral forces of the Al-Alisk clan, who now guard the crypt. This is doomed to be repeated until the spirit of the princess is freed. When the princess is freed, she will rejoin her beloved, and the nightly spirit battle will occur no more.

Martek caused the Crypt of Al-Alisk and the surrounding desert to be teleported into a sub-dimensional bubble. It forms yet another test that must be passed by those who would enter his Inner Sanctum.

The only way for the PCs to get to this area is to be teleported here from the Exit To Other

Worlds (Crystal Prism area 5d). This area, known as the Desert of Al-Alisk, exists in an unknown subdimensional bubble. Within this wilderness is the Crypt of Al-Alisk. The only way out of this area is to touch the Crystal Obelisk (Desert of Al-Alisk area 1) with the miniature crystal minaret.

Inner Sanctum of Martek

This was Martek's apartment and stronghold. Now it is his final resting place. Martek has laid an enchantment on all of the items within his Inner Sanctum, so that they may not be removed unless he gives permission.

Through the centuries, a legend has grown up concerning the Sphere of Martek, a magical device reputed to have wondrous power. It is through this device that Martek is said to have imprisoned the efreet Khalitharius in the first place. Actually, there is no such device, nor was there ever. Martek's Sphere of Power is, in reality, his magical knowledge and wisdom, gained through a lifetime of study. The only way for the Sphere of Power to be released is to bring Martek back to life.

The Star Gems have this power. When brought back to life, Martek will reward the diligence and courage of those who braved the dangers and bested the obstacles to bring him back to life. It was only to discourage people from bringing him back for inconsequential reasons that he set the obstacles in the first place. He will then proceed to banish Khalitharius forever.

The Inner Sanctum is in a subspace bubble on an unknown, closed plane. The only way it may be reached is by replacing any missing minarets from the Citadel of Martek model, found within the Crystal Prism.

Expected Play

PC Teleport Spells

The *teleport* spells of the PCs will not teleport them away from any of the areas in the Citadel of Martek. Once they have gone to an area, they cannot return. This effect takes place at the time that they are teleported to the Garden of the Cursed. If a PC attempts to *teleport* out of one of the Citadel areas, the spell will not function. It is not removed from the list of spells that can be cast, and if it was cast from a charged item, no charge was expended.

The *teleport* spells will teleport things from one place to another *within* an area, however, and the spells can be used to move things about. In fact, such spells are one of the two ways of moving anything in the Mobius Tower.

Competition from NPCs

Part of the excitement of play for the rest of the adventure will be to have the NPCs Trifakas, Pawnis, Sardok, and Percivilis described

below compete with the party. The party will first meet these NPCs in the Garden of the Cursed, and they may encounter them again and again on their way to Martek's tomb.

Trifakas, a human wizard, was the leader of a small band of thieves that he assembled to break into the fabled Citadel of Martek and secure the Sphere of Power for himself. After getting to the Garden of the Cursed he had only two of his band remaining, the drow elf Pawnis and the human Sardok. Trifakas discovered soon that without the Star Gems, he was trapped. He quickly learned of the guilders' peculiar religion, and, with the help of his magic, he set himself up as emissary of that religion, sent to prepare the guilders to enter their heaven. Now the guilders serve him with devotion, and honor his companions.

Percivilis, on the other hand, is far more open about his intentions. He is on a holy quest to save the desert from the ravages of a terrible efreet, even though it was never his destiny to do so. He entered the tomb three weeks before the PCs and discovered he was trapped. He awaits a party of adventurers who can open the doors to the Grand Hall, and allow him to complete his quest.

The object for both the PCs and these NPCs is to gain entrance to Martek's Inner Sanctum, and here lies the root of the competition between them. The first step is to enter the Grand Hall of the Crystal Prism with as many Star Gems as possible. Trifakas will try to get the Star Gems from the party for his own use. Percivilis will try to get the party to use the gems so he can proceed.

Because Trifakas is not interested in working with the party unless absolutely necessary, he will use guile and subterfuge to gain his ends. When he first hears that the party has arrived, he will be very interested in learning as much about them as he can, though he will take great pains to conceal this from the PCs. He will try to find out, using the skills of Pawnis and Sardok if necessary, if the PCs have the Star Gems. If he finds that they do, he will try to persuade them to use the gems under his supervision. Failing that, he will order the head of the guilders to have the gems stolen from the PCs and brought to him. If all else fails, he will ask to join the party with his friends, promising to be of use.

As soon as Percivilis hears of the party, he will attempt to meet them. He will lay out for them his quest and his need for help. He will listen patiently to the PCs and their tall tales, but unless they are particularly convincing, and thoroughly repentant should they let slip that it was *they* who released the efreet, he will not seem particularly willing to act in their service. It is possible that he would aid the party for a time, but it will be clear to the PCs that he distrusts their motives unless they have convinced him those motives are no less pure than

his own.

Once inside the Grand Hall, the PCs and NPCs will compete for the three miniature crystal minarets needed to complete the Citadel model in the Cathedral (area 4). Completing this model will allow them entry into the Martek's Inner Sanctum.

If you intend to add this complication, you must decide how the NPCs will behave. There are two ways of doing this. One way would be to have the NPCs precede the PCs wherever they go. This will add a great deal of excitement in the short run, as the PCs spot the NPCs ahead, but with careful planning on the part of the party, it could end abruptly if the PCs can manage to kill off or otherwise incapacitate the NPCs. It is not likely, unless you only use the NPCs as a plot device, that they will make it all the way to Martek's tomb, and so the excitement this mode generates is probably short-lived.

A second way, requiring perhaps a bit more work on your part, would be to plot out what the NPCs will do *before* you learn what the PCs intend. If you make up a time-line of NPC play, perhaps by actually playing out the NPC searches through the Citadel, then you will have a guide as to what takes place when the party does its own searches. The PCs could come upon the NPCs while they were hard at work, or vice versa. The NPCs could even solve part of the puzzle before the party, gaining whatever treasure is to be had. In either case, you should take care to play the NPCs in a reasonable way. The most important thing to the NPCs is their survival. The next most important thing will be to get to Martek's tomb. They should not be run in self-destruct mode, either by throwing them to the party like cannon fodder or to the monsters either. If you assume that the NPCs are at least as intelligent as the party, the end result will be more exciting, and more dangerous for the PCs.

It is not likely that the evil NPCs would split up, there being more safety in numbers, but it may be that one would scout ahead. Neither is it likely that the evil NPCs would fight amongst themselves, ignoring their ultimate safety. It is also unlikely that Percivilis would team up with the other three NPCs. Yet, you could use any of these paths of action if it will help make play more interesting.

The object here is to have fun yourself and to provide excitement and fun for your players. Only you know your group and how they will behave. If they have a hard time solving puzzles without any outside interference, keep the NPC activity low-key or dispense with it altogether. If they start to trash the dungeons too quickly, heighten the intensity of the NPC interaction. Use the NPCs to give the party some interesting choices, such as rescuing the NPCs from a wandering monster attack. Whatever occurs, the NPCs should not get to

the Inner Sanctum of Martek very far ahead of the party.

Trifakas (human wizard): AC 4; MV 12"; MU 12; hp 30; #AT 1; D 1d4; AL LE; SA and SD spell abilities; S 7; I 18; W 9; Dex 17; Con 12; Ch 15. He can cast the following spells once per day: *charm person, comprehend languages, jump, write; darkness 15-foot radius, forget, web, wizard lock; fireball, haste, lightning bolt, slow; fumble, polymorph other, polymorph self; feeblemind, magic jar, passwall, teleport; legend lore.*

Trifakas will behave in a gracious and priestly manner toward the PCs. He will be polite and helpful, all the while scheming and probing the PCs for their knowledge about the area and the location of the Star Gems. In his first conversation with the PCs, he will want to know whether they have any large gemstones, telling them that gems might be useful in activating the teleport platform where they arrived (Dais of Reception, area 4). He will also tell them that, to his knowledge, that is the only way out of the Garden. Trifakas knows that the teleport platform will not operate in reverse, but he does not want the PCs to experiment at the doors of the Grand Hall (area 6).

He knows that the names of the Star Gems must be used with the stones to open the doors to the Grand Hall. He has tried the words without the stones, but nothing happened. If really pressed, he will tell the PCs that the names of the gems that open the doors are "Pelar, Sellar, Kellar" and that they must be spoken in that order. This is a lie, of course, to make sure that the party does not get into the Grand Hall before he does. He also knows that the names of the Star Gems are sacred to the guilders, who will attack anyone speaking those words. He will not tell the names of the stones to anyone because, once he has the Star Gems, that is his only way out of the Garden of the Cursed.

Pawnis (drow elf fighter/thief): AC 5; MV 12"; F2/T8; hp 42; #AT 1; D 1d6; AL CE; SA magical abilities; SD +2 on all saves; MR 70%; S 12; I 13; W 10; Dex 16; Con 10; Ch 13. Pawnis is armed with a short sword and a dagger, both of which lost their drow magic in the desert; he has two darts coated with drow sleep poison (save vs. poison at -4 or sleep for 1d10+2 rounds) that he managed to keep well buried. He also wears chainmail armor and his outer wear, carefully sealed against the rays of the sun, still act like a *cloak of elvenkind* and *boots of elvenkind*. Pawnis has 12" infravision and



can use the following spells once per day: *dancing lights, darkness, faerie fire, detect magic, know alignment, levitate.*

Pawnis believes (incorrectly) that the key to the great doors has something to do with the Mound of the Lawgivers as well as with the three great stars from the guilders legends. He does not know what the Star Gems are or do, and Trifakas has not told him; nevertheless, he suspects Trifakas is withholding something, though he hides this suspicion. Pawnis knows that the Mound of the Lawgivers is a place of death and that very few will tread on its slopes. He is smart enough to see that his best shot at leaving the Garden of the Cursed is with Trifakas and Sardok.

Sardok (human thief): AC 4; MV 12"; T 10; hp 38; #AT 1; D 1d6+2; AL CE; S 14; I 16; W 10; Dex 15; Con 17; Ch 12.

Sardok, though cunning, cruel, and usually rude, is more loyal to Trifakas than is Pawnis. He trusts Trifakas more, and he truly believes that the wizard will get him out of here. He is willing to continue his deception of the guilders until that day.

Percivilis (human paladin): AC 4; MV 12"; P 6; hp 43; #AT 1; D 1d8; AL LG; S 17; I 16; W 13; Dex 15; Con 12; Ch 18.

Percivilis wears *chain mail +1* and uses a longsword. He has joined the palan-teen in the Garden of the Cursed because they seem like him. He knows the basic history of the peoples of the Garden, and how they came to be there. He also knows that Trifakas and his assistants are recent arrivals and nothing more than two thieves and a greedy wizard in search of power, fortune, and fame. Believing as he does that if you haven't anything nice to say that



you should say nothing at all, he will not speak ill of them.

Additional Play Areas

After the PCs travel through the Garden of the Cursed and the Grand Hall of the Crystal Prism, they will arrive at the Cathedral. There they will discover a crystal miniature of the Citadel of Martek with 3 minarets in place and 3 missing. Each of the missing minarets must be retrieved before the PCs can gain entrance to the Inner Sanctum of Martek and his tomb.

If you desire, this number can be increased. All you need to do to use one of your favorite designs is to hide the miniature crystal minaret somewhere in the design, remove that minaret from the model in the Cathedral, and light the appropriate hallway. You will need to describe the minaret's location when the PCs examine the appropriate Crystal Ball. In this way, play in the Citadel can be extended.

Furthermore, in the Desert of Al-Alisk, there are the ruins of Akhir, the once-great desert city from which the ghostly Lancers of Death make their nightly ride to meet the spirit guards of the Crypt of Al-Alisk. These ruins can be detailed to add yet another adventure area.

If you take advantage of these points of expansion, be sure that the designs you use allow the PCs to have the same chance of succeeding in their quest as they would have had without the designs. Balance beneficial things with the dangers.

Garden of the Cursed

The garden is just over 1 mile wide. The walls and ceiling of the garden absorb all magic that is used against them. Also, they cannot be damaged by normal attacks. The dome over the garden glows and darkens like daylight and nighttime.

The palan-teen and the guilders do not trust each other. If the PCs are friendly, they will be



treated kindly by both groups, but not trusted.

Once given the order to do so by Trifakas, Bandik will do whatever he has to to get the Gems. If he gets the Star Gems, Bandik will give them to Trifakas.

If Trifakas gets the gems, he will use them to open the doors of the Grand Hall (area 6). He will go down the hall with Pawnis and Sardok, take the Path of Protection, and descend into the Cathedral on the crystal disk.

As soon as they find out that the doors are open, all of the guilders and palan-teen will also go down the hall, believing that Grandal



(heaven) has been opened for them. When the guilders and palan-teen get to the Grand Hall (area 3) and see the flames and encounter the iron phoenix, they will flee in terror back to the Garden, leaving some of their dead behind.

If Trifakas gets the Star Gems, the PCs must be sure to get them back, for without all five, they will not be able to resurrect Martek. If the players have forgotten this important bit of information, or have become confused

because only three gems are required for entrance to the Grand Hall of the Crystal Prism, you will have to decide if you want to intervene or allow the story to play to no definite conclusion. It may be advisable to allow an Intelligence check to let the characters "remember" this key fact instead of have the work of nearly the whole campaign be lost because this is forgotten. Besides, Trifakas having some of the Star Gems will make chasing him through the Crystal Prism and the three test areas more exciting.

Crystal Prism

Once the crystal elevator has risen into the shaft, there is no way out of this area except by finding all of the missing miniature crystal minarets and replacing them in the model. The crystal elevator will remain down only if at least 40 lbs. is kept upon it.

Black Abyss

In each new area of the Black Abyss, a basic law of the universe changes. The PCs will experience more changes as they venture farther and farther into the Abyss. Each new change is added to the changes that came before it. First, distance changes, then time, then magic, and finally there is a total breakdown. Each change is explained in the area where it first takes place.

The DM must prepare for play in this area, because of the special judging required here. As the characters go through the Black Abyss, the distances between them will change; time will move them faster and slower and magic will go haywire. The changes will affect wandering monsters and NPCs just like they do the PCs. Thus, judging combat and even simple movement can become very difficult.

The information given in the next three sections describes how to judge the distortion affects. Play in the Black Abyss should not proceed until the DM has studied the information here carefully. The tables presented in the text are reproduced in the Encounter Area descriptions for ease of play.

Judging Distance Distortion

After the laws of distance begin to be distorted, the distances between figures likely will vary from turn to turn, affecting PCs, NPCs, and monsters alike. This distance distortion only affects how far figures are apart, and not the relative position of the figures. The distance distortion does *not* affect movement rate (MV), the range of missiles, the area of effect and range of spells, or the size of things. It *only* affects the distance between objects on the ground or in the air.

This means that, if two characters are in adjoining hexes each of which which used to be 120 feet across, they will continue to be in adjoining hexes each of which could be as little

as 12 feet across (they are nearly on top of each other) or as much as 1200 feet across (they are really far apart now). The range of the short-bow of one character and the *sleep* spell of the other does not change, nor does the area of effect of the *sleep* spell. The figures and all they possess remain the same size. Terrain features change in size, however, and so what is a 12-foot gap in one turn might be a 120-foot gap the next.

To determine what effect the distance distortion has, roll 1d8 and consult the Distance Distortion Table. That table will give the amount of distortion, if any, for every hex in the Black Abyss during the next game turn (10 rounds). The distortion may magnify distance by ten times as much or decrease it to one-tenth as much; it may even keep the distance the same.

Distance Distortion Table

Die Roll	Distance Change	New Map Hex Size
1	Everything is 10 times closer	1/10 old
2	Everything is 4 times closer	1/4 old
3	Everything is 2 times closer	1/2 old
4	No change	Same
5	No change	Same
6	Everything is 2 times farther	2x old
7	Everything is 4 times farther	4x old
8	Everything is 10 times farther	10x old

First calculate the size of the map hex. At the start of play in the Black Abyss, the map scale is 1 hex = 120 feet (12") wide. From the table, determine how to modify this scale. If the new hex-size is to be 1/10 the old, then the size of the hex is 12 feet wide; if it is to be 4x the old, the size of the hex will be 480 feet wide. No hex may be smaller than 12 feet wide, and none may be larger than 1200 feet wide; reroll if necessary so that this is true.

Now, using the rate of 1" of movement equals 10 feet, determine how many inches the PCs must move to cross a hex. Compare this to their actual MV, and you will be able to see how many hexes they can cross in that turn. At the end of the turn, roll again.

If the PCs have a random encounter, it may be necessary to determine the actual location of everyone. First, help the PCs indicate their marching order, including how far they are apart. Remember 10 feet = 1", and if they were in separate hexes before a distance distortion some PCs could be out of range of the encounter for several rounds. Next, determine the position of the monster(s). Probably they should be no closer than the next hex, and so it might be some time before melee is joined, particularly if the hexes are very wide.

Round by round, keeping careful track of the number since the last distortion roll, have the PCs indicate movement. For each round, determine how far the monsters can travel.

Resolve missile fire and magic using the normal ranges; these are not altered by the distance distortion. Resolve melee as usual.

When it comes time to make a new distortion roll, recalculate the hex size, then determine actually how far the PCs, NPCs, and monsters are apart. Monsters once out of range could be in range now, and vice versa. PCs and/or monsters could collide. Figures engaged in combat might no longer be in range. Saving throws might be required.

There are four special rules that apply, as listed below.

1. If two figures are grappling when the distance distortion takes place, they each must make a Dexterity check or be thrown to the ground and separated by 1d10 feet; calculate this first in feet, and then in inches of movement.
2. Assume that figures in melee are separated by $3/10$ ". Calculate the new distance between them after the distance distortion, and they may be out of melee.
3. Figures that collide because of distance distortion (separated by $2/10$ " or less) must make Dexterity checks or be knocked to the ground.
4. Characters may rope themselves together to keep the distance between them from becoming longer than the rope will allow. Whenever the distance between roped characters is *greater* than the length of rope between them, each must make a Dexterity check or fall to the ground as their feet are moved but their middles stay the same distance apart. After the distortion, whether they fall or not, they will only the length of the rope apart. If the distance diminishes, the rope will hang slack.

For example, Saya, a magic-user and Kamu, a fighter, enter this area for the first time. At first, each hex is 120 feet across. Saya and Kamu are standing 4" apart. At the beginning of the next turn, the DM rolls a 7 on the Distance Distortion Table above. The DM first figures out the new hex size. The table says that it is 4x the old, which makes it 480 feet wide. Because this new hex size is less than 1,200 feet and greater than 12 feet, it is okay to use this change. Next, the table says that the distances become 4x greater. Suddenly, Kamu and Saya are 16" apart instead of 4".

If the DM had rolled a 1 instead, the size of the hex would have become 12 feet wide. Kamu and Saya would have been 10 times closer, and so they would have ended up shoulder to shoulder after the distortion decreased the 4" they were apart to only $4/10$ ". Any closer, and they might have collided.

Judging Time-Frame Distortion

Within much of the Black Abyss, the laws of time also change. Distance in the area is still distorted, but now each individual PC, NPC, and monster may be moving slower or faster than usual, to the time distortion effects here.

Keep running the distance changes as explained above. In addition, at the beginning of every turn, roll 1d6 and consult the Time Distortion Table. This will give the relative time speed of the individual figure in question, as well as the modifiers to use when figuring number and success of attacks and movement.

Time Distortion Table

Die Roll	Time Frame	To Hit Modifier	#AT Modifier	MV Modifier
1	very slow	-2	/4	/4
2	slow	-1	/2	/2
3	normal	none	none	none
4	normal	none	none	none
5	fast	+1	x2	x2
6	very fast	+2	x4	x4

Characters and monsters with fast time-frame can move faster than those with slower time-frames. Each character will always think that he is moving normally and that the people around him are changing speed. When a character is in a slow time-frame, the people around him will seem to be moving unbelievably fast. When a character is in a fast time-frame, everyone around him will seem to be moving in slow motion.

Each character and monster's ability to move and fight will be changed by the modifiers for his roll on the table above. For example, a fighter in a "very fast" time-frame will move 4x faster than normal, and so his MV is four times as great; if he has an MV of 12", his new MV will be 48". He also will have a to hit modifier of +2 because he moves so fast; when rolling to see if an attack was successful, add 2 to the die roll. He will get 4 times as many attacks, as well. This means that, if he were able to attack 3 times every 2 rounds, he could attack an unbelievable 6 times each round.

For magic users who cast spells, the to hit modifier will affect the saving throw on automatic hit attacks. If an MU rolls a 1 on the Time Distortion Table, he will not only have 1/4 his normal attacks (probably only one spell every 4 rounds), but the monsters he attacks magically will add 2 to their saving throw because it takes him so long to cast his spells.

Judging Magic Distortion

Even farther into the Black Abyss, the laws of magic also change. Spells may function in strange ways, or they may not function at all; spells intended to be cast may have effects that

are totally different; magical items do not always work. Whenever a spell is cast, roll 1d10 and consult the Spell Distortion Table to give the distortion effect.

Spell Distortion Table

- 1-2 Random spell of same level cast
- 3 Random spell of next lower level cast
- 4 Random spell of next higher level cast
- 5 Random spell of random level cast
- 6 Spell fails to work
- 7 Intended spell backfires against caster
- 8-10 Intended spell cast normally

These effects are explained in the paragraphs below. When a PC tries to cast a spell and a different spell goes off instead, do not tell the player which spell was really cast. Just describe the spell's visual effects and any effect it has on the target. Such miscast spells are a combination of two spells, mingled by the magic distortion. The range, number or area affected, and duration of the spell actually cast are those of the spell intended. The target's saving throw, however, is for the spell actually cast.

- 1-2. In the *Players Handbook*, find the list of spells of the same level as the spellcaster tried to cast. Roll randomly on that list to find the spell that is really cast.
3. In the *Players Handbook*, find the list with spells one level lower than the one the spellcaster tried to cast. Roll randomly on that list to find the spell that is really cast.
4. In the *Players Handbook*, find the list with spells one level higher than the one the spellcaster tried to cast. Roll randomly on that list to find the spell that is really cast.
5. First determine the level of the spell actually cast. For Cleric and Druid spells, roll 1d8, rerolling if the result is 8. For magic-user spells, roll 1d10, rerolling if the result is 10. The number that is rolled is the level of the spell that is really cast. Because of the magic distortion, the spells may be of a higher level than the caster could normally use.

In the *Players Handbook*, find the list of spells of the type and level just determined. Roll randomly on that list to find the spell that is really cast.

6. The spell goes off, removing it from the list of spells that the spellcaster can cast, but it does not work at all. Do not tell this to the player, instead just say that there are no visual effects.
7. The intended spell turns on the spellcaster. All effects are normal and usually saving throws apply.

8-10. The spell is cast normally. Even here, just describe the effects.

Do not use the table for magical items used, including magical weapons and armor. Single-purpose magical items have a 50% chance of working every time they are used. This means that such items as a *sword +1*, a *shield +2*, and a *wand of fireballs* will work 50% of the time as they are intended; the other 50% of the time they do not function magically, though a magical sword is still a sword and a shield is still a shield, etc.

Multi-purpose items will *always* behave magically. Half the time they will behave as expected. The other 50% of the time they will use one of the other magical properties chosen at random. Thus, a *sword +1* that also flies or detects invisible objects, will be +1 in combat only 50% of the time. The rest of the time it will randomly cause the user to *fly* for one round or attempt to *detect invisible* for the round.

Getting the Party Out

The close of play in this area is particularly difficult if the PCs do not act together. When the crystal minaret is discovered and grasped, there will be only 10 rounds in which all PCs must leave the area by falling, or jumping into, the whirling storm over the Black Abyss. The characters nearby when the minaret is grasped will have no problem, though they will apparently be in danger as the island they stand on explodes into small fragments and they are flung into the storm. What the players will not know, and may not discover, is that the PCs that are not in *apparent* danger are the ones that may never return.

This problem should be thought out very carefully by the DM before play, so that he may judge it according to the nature of the players he games with. If the players cannot handle such an outcome, the DM must find some way to give hints as to the way the PCs must behave.

Mobius Tower

The only way the characters can get out of the Mobius Tower is by inverting the hourglass behind the shimmering curtain in the Tower of Time (Level 4, area 26).

The PCs may try to make their way through an "outer" wall to escape the tower. This is not possible, for if the PCs punch through one of the 10-foot-thick walls, a hole will appear in the wall on the opposite side of that level. For example, a character burrowing through the "northwest" wall in the Tower of Time (Level 4, area 26) will get a glimpse of their backs as a hole appears through the "southeast" wall of that same room. If the PCs use a *passwall* spell to leave the "west" wall of the Buffet (Level 1, area 9), they will

appear through the "east" wall of the Sheik's Apartment (Level 1, area 5).

The PCs may run into some of the NPCs who were able to make it into the Citadel, but were unable to get beyond the Garden of the Cursed before the PCs came with the Star Gems. Depending on how the DM chooses to play this, any or all of these NPCs may be in or may enter the Tower while the PCs search it. The movements of these NPCs may be randomly determined, or the DM may decide to make things a bit more interesting for the players by having the NPCs venture just ahead of the PCs, wherever they go, unless the PCs take pains to stop them from doing so. In either case, the DM should keep track of Trifakas, Pawnis, or Sardok if they are in this area while the PCs are here.

Time-trapped people and things cannot be moved or damaged unless their time-frame is changed to the PCs' time-frame. There are only two ways of doing that:

1. *Teleport* the object into the Tower of Time (Level 4, area 26). Anything so brought into this room will shift to the time-frame of the PCs and remain there from then on, being released from the time-trap.
2. Change the object's time-frame with the *Medallion of Time* found in the Audience Chamber (Level 3, area 25). As this hangs about the neck of the Guardian of Time there, and as he will not give this up without a fight, this could be interesting, indeed.

Crypt of Al-Alisk

The PCs must make their way through the Desert of Al-Alisk to the Crypt of Al-Alisk. Then, they must retrieve the miniature crystal minaret from feet of the princess in the Revolving Tomb. To leave this subdimensional bubble, the PCs must touch the miniature crystal minaret to the Crystal Prism located in the center of the desert area.

Inner Sanctum of Martek

There is not expected to be any combat here, merely the solving of the final puzzle and the raising of Martek. Clues to the expected behavior may be found in case the players do not see what to do at first.

In the Vault of Martek, wherein Martek's bones lie in state, there are sockets for all five Star Gems. When these are replaced in the sockets, they will activate the magic Martek left for his resurrection. This is the culmination of the campaign, and the only thing that remains is the wrap-up.

Martek will be thankful and generous, allowing the PCs to take three items of treasure. Then he will send them wherever they want to go, allowing them to watch his banish-

ment of Khalitharius before they go.

The only way out of the Inner Sanctum is through the Transdimensional Door (area 5). Unless Martek says that an item found in his Inner Sanctum can be removed, it cannot be; the Star Gems, though they were brought here by the party, are similarly enchanted.

Pillar of Martek Encounter Areas

Use Map 14-1 from the *Map Booklet* for play in this area. This corresponds to Desert of Desolation area 26 on Map 6-1.

1. Upper Monument

Three 30-foot-tall crystal spires tower above a 10-foot-wide hexagonal base of polished black stone. The spires, which show no marks from time and weather, stand at the points of the hexagon, one to the north, one to the east, and one to the west. Inscriptions in the ancient alphabet have been carved into the spires. Two forked prongs spread from the top of each crystal like the wings of a mighty Phoenix. In the center of platform, there is a circle of grey.

The hexagon is unscratched and highly polished. The inlaid marble circle is so flawlessly done that there is no seam between the grey marble circle and the black marble hexagon. The crystal spires cannot be damaged by anything except the most drastic magical means. There is a secret door in the north side of the north spire.

The inscriptions on the crystal spires are reproduced as Inscriptions 14A-14C on the reverse of the DM's fold up map. They may be translated as follows:

(North Spire Inscription, number 14A)
My name is Martek and rising here before you is the tomb of my body. From here shall my Sphere of Power be called forth in the appointed day from beyond death and bring salvation to the desert peoples.

(East Spire Inscription, number 14B)
The mighty crystal spires rise around the entrance to my tomb. The bearers of the gems of stars must carry them to me and thereby gain their prize.

(West Spire Inscription, number 14C)
Only once each day, when the crystals sound, will the way be made clear. You have but to knock to enter.

The crystals will ring with a light tone if they

are struck gently. Whenever one of the crystal spires is struck by any character's full force with any item, however, the crystal will sound a vibrating tone, like a tuning fork. The sound will seem to die out for a moment, then start to build again, only louder and from all three crystals. Read the following boxed description to the players when this happens.

As the ringing tone of the crystals gets louder and louder, the air starts to shimmer around you. Suddenly, overhead, the sky ripples in waves of clear light and then opens up, revealing an immense crystal citadel floating 500 feet in the air. The structure, which is perhaps six miles wide at the base, has six elegant minaret towers. It appears that the legendary tomb of Martek was here, in the open, all these centuries.

A pillar of light suddenly comes down from the building and covers the grey marble part of the platform.

The large crystal building that appears is Martek's tomb. Martek's tomb will remain visible and the pillar of light active for 1 turn after the summoning tone. After that, the light will rise back into the tomb and the tomb will disappear. Because the tomb is usually in an alternate plane, it will remain hidden until it is brought down by the crystals. Martek's tomb will only appear once per day.

Characters who are standing under, or enter into the pillar of light will rise into it. They will be blinded for a moment as they are teleported to the Dais of Reception in the Garden of the Cursed (Garden Area 4).

2. Entry Chamber

A dry, dusty staircase descends to an archway about 20 feet below the platform. There is a 30-foot-wide by 40-foot-long room on the other side of the archway. In the center of the far wall, a golden door stands shut, an altar 10 feet in front of it. A golden disk is inlaid in the top of the altar.

There are secret doors at the north ends of both the east and west side walls. When the disk is pressed, the golden door will start to rise and a large stone door will start to lower over the archway exit to the stairs. As soon as the golden door has lifted 6 inches, a wall of lightning from floor-to-ceiling and wall-to-wall will appear in front of the south wall. The lightning will move north, through the room, giving 12d6 damage points. Save vs. spells for half damage. The wall of lightning will stop when it gets to the north wall. After one turn, the archway will open and the south door will shut.

The opening of the golden door, the closing of the stone door, and the wall of lightning

moving across the whole room will take one round. An immediate reaction on the part of a PC will allow a Dexterity check to see if that PC dove through the archway before the stone door fell. The same thing will happen every time the disk is pressed.

3. Tomb Room

This room is roughly 30 feet square. There is a sarcophagus, an ornate stone coffin, in the center of the room. Everything is covered with cobwebs and a thick layer of dust.

There are two secret doors, one on the north end of each side wall. The sarcophagus is empty and there is nothing else in the room.

4. Corridor

This 50-foot-long corridor has an arched ceiling 10 feet overhead. It doesn't look as though anyone has been here for centuries.

There is a secret door at each end of the inner wall. There is a secret door in the middle of the outer wall that sets off a trap, releasing a spear. The spear flies straight across the hall, striking anyone who happens to be in the way. The spear needs a 10 to hit AC 0 and does 1d6 damage points if it hits. Characters in front of the door who make a Dexterity check take only half damage.

Garden of the Cursed Encounter Areas

For play in this area, refer to Map 14-2 found in the *Map Booklet*.

Garden of the Cursed Random Encounters

Check for random encounters once every 3 turns. Roll 1d6, and on a roll of 1, roll 1d12 and consult the Garden Random Encounter Table below to determine the encounter that takes place.

Garden Random Encounter Table

- 2d4 Palan-teen: AC 8; MV 15"; HD 4; #AT 2; D 1d8; AL LG with Chaotic tendencies.
- 1d6 Guilders: AC 7; MV 9"; HD 3; #AT 1; D 1d4; AL CE.
- 1d8 Giant Tarantulas: AC 6; MV 18"; HD 2+2; #AT 1; D 1d4 + paralysis poison; AL N.

4. 1d4 Giant Scorpions: AC 3; MV 15"; HD 5+5; #AT 3; D 1d10/1d10 /1d4 + poison; AL N; SA poison stinger.
5. 1d4 Grenade Palms: AC 10; MV 0"; HD 10; #AT 1d8; D 1d8; AL N. These are trees that have fruit that look like pineapples. These trees are usually about 33 feet tall. If anyone walks within 5 feet of the trunk of a grenade palm, there is a 20% chance that the vibration of his movements will make a fruit fall from the tree. There is a 95% chance that the grenade fruit will explode when it hits the ground, doing 2d8 points of damage to anyone within 10 feet of the explosion. If the fruit is caught, the chance of explosion is only 40%. The grenade fruit may be picked and carried, to be used later, but there is always a 10% chance that the fruit will explode whenever the character carrying them falls or otherwise bumps the fruit accidentally. The fruit has evolved exploding as a way of scattering its own seeds far enough away from itself to insure enough distance between the trees. Grenade palms do not work or grow outside of Martek's tomb, except in the Dome of Flight in Pharaoh Amun-Re's tomb.
6. 2d6 Guilders: AC 7; MV 9"; HD 3; #AT 3; D 1d4; AL CE.
7. 1d8 Palan-teen: AC 8; MV 15"; HD 4; #AT 2; D 1d8; AL LG with chaotic tendencies.
8. Trifakas (human wizard): AC 4; MV 12"; MU 10; hp 30; #AT 1; D 1d4; AL LE; SA and SD spell abilities.
9. Pawnis (drow elf fighter/thief): AC 5; MV 12"; F2/T8; hp 42; #AT 1; D 1d6; AL CE; SA magical abilities; SD +2 on all saves; MR 70%.
10. Sardok (human thief): AC 4; MV 12"; T 10; hp 38; #AT 1; D 1d6+2; AL CE.
11. Villagemaster Bandik (guilder thief): AC 6; MV 12"; F3/T12; hp 20; #AT 3; D 1d4/1d4/1d4; AL CE with N tendencies; 12th level thief abilities.
12. Percivilis (human paladin): AC 4; MV 12"; P 6; hp 43; #AT 1; D 1d8; AL LG.

1. Garden

In this clearing of soft ferns and small trees, the lush greenery is blown gently by cool breezes. Beside the trails and along the edge of the clearing, bushes of ruby-red berries and trees of sweet ripe fruit give way to thick jungle. The sky is covered by a gigantic dome of glowing light.

There is no movement restriction here. The fruit may be eaten to provide nourishment.

The ruby-red berries can be eaten to restore damage; they will heal 1-6 points once each day. The berries go bad three days after they are picked. The berries have no powers and their bushes will not grow outside of Martek's tomb.

2. Jungle

Thick, wet jungle blocks the way. Huge trees with large roots darken the area and provide cover. Vines drape from the branches overhead and creep over the spongy moss that covers the ground. Tall plants grow to man-height, their thorny stems an effective barrier.

All movement is at $\frac{1}{4}$ normal for everyone except elves. Maximum sighting distance in this area is 20 feet.

3. Waters of the Garden

Before reading the boxed description, tell the players if this is a river or a lake.

The water is cool and refreshing, very clear, and clean. Small fish can be seen swimming in it. The bottom is sandy in some places and rocky in others. Various plants grow on the bottom.

The water is good to drink. The fish are good to eat and large ones can be caught in the lakes. The plants are not harmful, but they taste bad.

4. Dais of Reception

On this hexagonal platform, nearly 600 feet wide, six white marble pillars rise high overhead toward an opalescent dome. Hanging from the pillars, a gigantic gong gives forth a loud BONG, echoing across the area. Across the clearing in front of this area, jungle growth blocks the sight, but the domed ceiling continues as far as you can see. Two hundred feet of stairs lead up to this platform from the ground. Beside them, rivers empty into the wall.

The gong will only sound when someone is teleported up into the tomb. Within 1d6 rounds after the PCs appear, 20 guilders will arrive cheering, and 1d6 rounds after that, Pawnis will arrive. When he does, the guilder villagers will bow down before him. Pawnis will welcome the PCs with open arms. He appears to be more robust and healthy than the villagers. In a most friendly way, he will want to know all about the party and their quest. He will direct the villagers to take the PCs to a great feast and rest.

Anything that goes into the water openings on either side of the platform will be teleported to the top of the waterfall at Grandal (area 6).

20 Guilders: AC 7; MV 9"; HD 3; #AT 1; D 1d4; AL CE (N); 12th level thief abilities.

5. Guilder Village

The guilder village lies quietly near a calm lake, which is about 200 feet wide and 500 feet long. Among the wooden huts with woven mat roofs, the villagers go quietly about their business. On the north side of the lake, there are 15 heavy bamboo cages, all are empty.

There are a total of 88 guilders in the Garden. At least 20 of them will be in the village at all times.

If the PCs have accepted Pawnis' invitation, they will be brought here as soon as they arrive. At this time, the guilders will prepare a feast of tarantula meat and squashes for the PCs and invite them to eat. After 1d10 rounds, Villagemaster Bandik will arrive, having been instructed by Trifakas to find out if the PCs have the Star Gems. Remember that if the Star of Melos-Pelar is glowing, it will be very hard to hide.

Given that the guilder religion involves theft, there is a likelihood that one of the guilders will attempt to steal from the party. If a guildler is caught at this, Pawnis or Bandik will explain the guildler religion to the PCs. If the Star Gems are displayed openly, or if the names of the Star Gems are spoken aloud, the villagers will immediately attempt to capture the PCs for later stoning.

If the guilders get into a fight with the PCs, or have to capture them to steal the gems, they will put the PCs in the cages, one prisoner to each cage. The cages are used to hold prisoners and carry them to the Mound of the Lawgivers (area 10), where they would be stoned to death. These cages can be broken with a successful *bend bars/lift gates* roll at +20%.

20-88 Guilders: AC 7; MV 9"; HD 3; #AT 1; D 1d4; AL CE (N); 12th level thief abilities.

Villagemaster Bandik (guildler thief): AC 6; MV 12"; F3/T12; hp 20; #AT 3; D 1d4/1d4/1d4; AL CE with N tendencies; 12th level thief abilities. Bandik was the master of the guilders until he was convinced that Trifakas was an emissary from Grandal. Now, Bandik is loyal to Trifakas and will obey him without question until such time as he believes that Trifakas has gone against the guilders' sacred laws.

6. Grandal

Majestic twin doors of shining silver tower 100 feet to an archway. They are each 30 feet wide and have no markings, handles, or hinges. From 10-foot-wide openings on either side of the doors, 75-foot waterfalls cascade down into pools from which flow rivers.

In front of the doors, there is a platform made of a strange polished blue-grey stone. A small altar stands on the platform, 50 feet in front of the doors. It has three oddly shaped holes carved into the side facing the doors.

This is the Grand Hall (the name Grandal is a corruption of this) of the Crystal Prism. It is through these doors that the PCs must go to reach Martek's tomb. This fact is known by Trifakas, Pawnis, and Percivilis. The doors cannot be opened by any physical or magical means except by using the Star Gems as directed on the Ancient Obelisk (area 9). The guilders believe that they must go through these doors to meet with the Masterguild, their god. The palan-teen believe that when these doors are opened, the guilders will be demolished by the good that flows out.

If the PCs put three of the Star Gems in the holes on the altar and speak their names in order, followed by the word "Re," the 1,001 doors of the Grand Hall beyond will all open by themselves. If the words are spoken out of order while the gems are in place, a *flame strike* will smash down from above onto the speaker.

The waterfalls are fed by water *teleported* from the Dais of Reception (area 4).

7. Trifakas' Camp

In a small clearing in the trees, there is a small, well built, log hut.

This hut belongs to Trifakas. He and Sardok live here.

8. Camp of the Palan-teen

Near the center of a large clearing stands a fort roughly 50 feet square. Its log walls are 10 feet tall and sharpened on the top; there is only one door. Smoke can be seen rising out of the compound inside the walls. The underbrush has all been carefully cleared away outside the walls for about 50 feet.

This is the camp of the palan-teen. There are a total of 52 palan-teen in the Garden, 20 of whom will always be present here. They always have a lookout posted on each corner of the walls. When the lookouts see the PCs, they will call out to them to halt and identify

themselves. When the palan-teen realize that the PCs aren't guilders, Percivilis and two palan-teen will come out to meet them and escort them into the fort. When the PCs enter the fort, read them the following boxed description.

The ground inside the fort is hard-packed dirt. There are several wooden huts with woven-mat roofs in the compound. There is a thin ledge that runs around the inside of the wall with ladders in each corner. Four men stand guard-duty, one in each corner.

20-52 Palan-teen: AC 8; MV 15"; HD 4; #AT 2; D 1d6; AL LG (C).

9. Obelisk of the Ancients

Buried under tall grasses and brush, an ancient obelisk is hidden. The writings on its sides are worn down by time, but they are still legible. The inscriptions are written in the ancient alphabet.

The inscription is a set of instructions to opening the doors of the Grand Hall (area 6). Reproduced as Inscription 14-D on the reverse of the DM's fold-up map, it reads:

The day shall come when men of valour enter this garden and bring with them the great Star Stones. This has been foretold by Martek in the Times of Light. They will place three stones in the altar and recite their names. By finally uttering Re shall the 1,001 doors be opened before them. Then will the test of their courage begin.

10. Mound of the Lawgivers

A hill, completely covered with small stones, rises from the grasses. There are crushed bones mixed in with the stones in the center of the hill.

This is a stoning hill where both the palan-teen and guilders stone their prisoners and enemies. Should the PCs ever be on the receiving end of one of these ceremonies, you should know that each stone strikes for 1d4-1 damage points of damage. There is an endless supply of stones.

Grand Hall of the Crystal Prism Encounter Areas

For play in this area use Maps 14-3 and 14-4 in the *Map Booklet*.

Crystal Prism Random Encounters

There are no random encounters in this area, though there may be encounters with NPCs. The DM must determine if and when the PCs meet Trifakas, Pawnis, and Sardok in this area. This means that if those NPCs are still alive, the DM must keep careful track of where they are.

1. One Thousand One Doors

At the sides of this hall made of glassteel, a blue fire burns fiercely. The hall is 30 feet wide and 100 feet tall. Every fifteen feet, a glassteel wall blocks the hall. There is an open door in the center of each wall.

This hall is 3 miles long and has 1,001 doors. Each door will be shut and *wizard locked* at 15th level unless the altar in the Garden of the Cursed (Grandal, area 6) has been properly activated. When it is, all the doors open by themselves. There are no exits except straight north and straight south. The glassteel cannot be damaged by magical or normal attacks.

The firepits to either side seem to be endless; they are 100 feet deep. Any character who falls into a firepit will take 2d10 points of burn damage per round, though the flames burn without heat.

2. Final Doors

The hallway ends at closed golden double doors 30 feet wide by 100 feet tall. The gold doors have ornately carved glowing runes cut into them. Ten-foot-wide arched corridors lead off to the east and west.

If the villagers from the Garden of the Cursed got here before the PCs, several of them will be lying dead, their bodies smoldering and badly burned.

The runes magically change to the easiest language for each reader, saying:

My monument to Phoenix
Good friend and true
Stands watch over the way
To the gate of my tomb.

Walk that path straight and narrow
Do not waver or falter
And you chance will given
To come to my altar.

The central doors and the doors at the ends of the side passages open easily into the Grand Hall (area 3). Only the central doors lead to the Path of Passage, which is safe from attacks by the iron phoenix.

3. Grand Hall

Light and flame fill the octagonal room ahead. Polished black glassteel reflects the flames into a seeming eternity. Jets of fire soar 100 feet above you into the domed ceiling from four deep pits. There are golden double doors in the center of the opposite wall, 110 feet away, with two single golden at either end of the wall. There are similar door arrangements on each of the side walls. The short, diagonal walls have no doors.

The pits are shaped to form a platform in front of each set of doors. Pathways lead from each of these to the center of the room, where there is a 30-foot-diameter platform with a 10-foot-diameter, blue crystal disk in its center. A pathway next to the walls connects the outer platforms.

Hanging from the ceiling is a black frame that sits like a tent over the central platform. A stately iron phoenix sits on the frame.

The iron phoenix will activate as soon as any creature enters 10 feet into the Grand Hall. First the phoenix will fly toward the PCs. Next, while within range, it will alternate its sonic screeches with its *flame strikes*. Once these attacks are exhausted, it will attack with its talons while swooping down at the PC; it can swoop every other round. If necessary, the iron phoenix will land and use its beak, though that is clearly the last resort. If it is killed, it will wobble to the fireplace and fall in, resurrecting within 24 hours.

The Path of Passage is the 10-foot-wide path that runs from the central southern doors straight to the central platform. The Path of Passage includes the small disk, but not the whole central platform. The iron phoenix will always miss, with both physical and magical attacks, any character on the Path of Passage; sonic screeches will be delivered from beyond the 60-foot range, and *flame strikes* will strike to either side.

Characters on the Path of Passage cannot accidentally fall into the flaming pits. Characters who fall into the pits will take 2d10 points of burn damage every round they are in the pit. The pits are 100 feet deep. Remember that the fire in the pit will burn through ropes.

Any weight over 40 lbs. (400 gp) that is placed on the blue crystal disk will cause it to lower slowly down a shaft into the floor. It will descend 100 feet through a dark, smooth shaft 10 feet in diameter, emerging in the Cathedral (area 4). When there is less than 40 lbs. on the disk, it will slowly rise back up the shaft.

Iron Phoenix: AC 3; MV 12"/24"; HD 10; hp 80; #AT 2 or 1; D 2d6/2d6 (claw attacks while airborne) or 1d12 (beak attack on

ground); AL N; SA screech gives 2d20 sonic damage three times per day within 60 feet (save vs. spells for half damage), *flame strike* 3 times per day; SD regenerates 5 hp per round, resurrects within 24 hours.

4. Cathedral

Use the Map 14-4 for play in this area.

The walls of the shaft open up as the disk drops through the ceiling of an amazingly large room. This is a cathedral of crystal, brilliantly lit from within. The room is an enormous hexagon, 420 feet from side to side. The disk continues to drop from the dizzy height of 1,200 feet, finally coming to rest gently on the floor about 90 feet from the southern corner of the room.

In the center of the room, there is a platform of white stone. Stairs lead up to it from all sides. There are crystals on top of the platform, but they are too far away to see clearly.

An arched hall, 60 feet wide and 200 feet tall opens to the south; it is dark. There are five other hallways, each at one of the other corners of this hexagonal room. The passageways to the north, northwest, and southeast are brightly lit and the others are dark.

A crystal miniature of the Citadel of Martek sits on top of the platform. It looks just like what the PCs saw when they struck the Pillars of Martek, except that three of the miniature minarets are missing. The six corners of the model face the six hallways in the cathedral. The missing minarets are from the corners that face the lit hallways. The remaining minarets, which cannot be removed, face the darkened corridors.

When one of the missing minarets is put into place, the hallway that it faces will become dark. When all of the crystal minarets are in place, everyone in this room will be lifted off the floor, reduced in size, pulled into the model, which will teleport them to the Entry Hall (Inner Sanctum area 1).

The runes on the platform rearrange to the language most convenient for the individual PC. They say:

Six paths to glory,
Six paths to doom.
Six paths to minarets
The keys to my tomb.

Replace the six minarets
From the places now hidden
And you may then enter.
To my tomb you'll be bidden.

Be valiant and faithful
There is always a way

And if you survive it
You'll have glory this day.

5. Crystal Balls

Whenever a PC enters areas 5a-5f, read the boxed description below. Areas 5c, 5e, and 5f are dark; the other areas are well lighted.

In the center of this area, a crystal ball sits on a dais of white polished stone.

Each crystal ball shows where one of the crystal minarets is. The crystal balls cannot be removed. The crystal balls in areas 5c, 5e, and 5f are dark and cloudy; the others are lighted. When a lighted crystal ball is inspected, read the boxed description below appropriate to the specific area.

5a. A platform of giant crystals floats in the center of a whirlpool of red storm clouds that sinks into the depths below. The island and the air above it glow with a soft, white light. In the center of the island, a miniature crystal minaret stands on top of a crystal base.

5b. Within a dimly lit room 40 feet square, a crystal minaret rests on a red satin pillow. The torches on the walls give off the light, but they do not flicker. Four doors lead out of the room; two of these are open.

5d. A young woman kneels inside a crystal cylinder, her face turned upward, a tear half-way down her cheek. Her lovely oval face is set off by dark, almond eyes and by silken hair that sweeps to her waist. At her knee sits a brass ball of curious and intricate workmanship, and, half hidden by the folds of her gown, a crystal minaret lies beside her. She is absolutely motionless.

6. Exit to Other Worlds

In the center of this room, which is 180 feet across, stands a 30-foot-diameter disk raised two feet off the floor.

This area is identical to the Return from Other Worlds (area 6) in appearance. The disk is a teleporter to one of the places where the miniature crystal minarets are hidden. Areas 6c, 6e, and 6f are dark, and the disks there do not work; the minarets in these places already have been found. Areas 6a, 6b, and 6d are well-lighted and the disks there will teleport anyone stepping onto them to the following places:

Teleport	Area Teleported To
6a	Black Abyss, area 1a
6b	Mobius Tower, area 1
6d	Desert of Al-Alisk, area 1

7. Return from Other Worlds

In the center of this room, which is 180 feet across, stands a 30-foot-diameter disk raised two feet off the floor.

This area is identical in appearance to Exit to Other Worlds (area 6). The disk here is the receiving end of a teleport to bring the characters and the crystal minaret back. Areas 7c, 7e, and 7f are dark because the crystal minarets are already in place in the model in area 4. Areas 7a, 7b, and 7d will become dark when the characters retrieve the minarets from their hiding places and place them in the Citadel model.

Black Abyss Encounter Areas

For play in this area, use Map 14-5 from the *Map Booklet*. Judging play in this area is more difficult than normal. Movement, magic, and melee all are different than usual. Important information on how to play in this area is given in the section on Expected Play. *Play should not begin in this area until the DM has carefully read the material there.*

Black Abyss Random Encounters

Check for random encounters once every three turns. A roll of 1 on 1d6 means that the PCs encounter something. When an encounter takes place, roll 1d12 and use the encounter with that number from the Black Abyss Random Encounter Table below.

All monsters are affected by the same changes in the Black Abyss that the characters are, and so their movement rate may be much faster or slower than that of any individual PC. The total number of monsters is kept small so that the distortion effects may be determined for each individual monster.

The wandering monsters should appear or first be seen 1d6 x 10 feet from the nearest PC. Measure the distance according to whatever distance scale is being used when the monsters appear.

Black Abyss Random Encounter Table

- 1 Xorn: AC -2; MV 9"; HD 7+7; #AT 4; D 1-3(x3)/6d4; AL N; SA surprise on a 1-5.
- 1-3 Umler Hulks: AC 2; MV 6"; HD 8+8; #AT 3; D 3d4/3d4/1d6+1d6+1d5; AL CE.
- 1d6 Troglydites: AC 5; MV 12"; HD 2; #AT

1; D 1d6; AL CE; SA revulsion odor.

4. 1d6 Spectral Minions: AC 2; MV 30"; HD 3; #AT 3; D 1d6; AL CE.
5. 1-3 Otyughs: AC 3; MV 6"; HD 7; #AT 3; D 1d8/1d8/1d4+1; AL N; SA disease.
6. 1 Neo-Otyugh: AC 0; MV 6"; HD 11; #AT 3; D 2d6/2d6/1-3; AL N; SA disease; SD never surprised.
7. 1-3 Doppelgangers: AC 5; MV 9"; HD 4; #AT 1; D 1d12; AL N; SA surprise on 1-4; shape change.
8. 1d6 Spectral Minions: AC 2; MV 30"; HD 3; #AT 1; D 1d6; AL CE.
9. 1-3 Adventurers: AC 3; MV 12"; HD 7; #AT 1; D 1d8+2; AL NG.
10. 1 Djinni: AC 4; MV 9"/24"; HD 73; hp 43; #AT 1; D 2d8; AL CG.
11. 1 Efreeti: AC 2; MV 9"/24"; HD 10; hp 52; #AT 1; D 3d8; AL N with NE tendencies; SA and SD spell abilities.
12. 1 Hero: AC 0; MV 12"; HD 10; hp 61; #AT 2; D 1d8+2; AL LG.

1a. South Wall

You appear at the back of a huge cavern built of polished white stone. The top of the cavern is at a fantastic height. The walls, stretching into the distance, are lined with spots of brilliant white light. Trees and shrubbery grow in this green, garden-like area. Well-trimmed bushes line several neat paths down the hall. Behind you, two large carved stone figures stand at the back wall of the hall. One is labeled *Time* and the other is labeled *Space*. Between them, there is a large obelisk with writings carved into it. Up ahead, the ceiling ends and you can see glowing red light through it.

The writing on the obelisk reforms to read:

Beyond the knowledge of mortal man
Guardians of the worlds stand guard
They look toward the crystal minaret
And watch that path so hard.

Beyond the end of space and time
Beyond all magic's sphere
Where all the world breaks down
And chaos does appear.

'Tis there the crystal minaret
Awaits that valiant day
When men shall walk paths of oblivion
And take that key so far away.

As the PCs move down the hall, they should notice that the glowing lights on the walls are getting dimmer. The lush trees and shrubbery will start to appear withered.

1b. Midhall

The vast ceiling, high overhead, suddenly ends in a jagged edge of broken stone. Thousands of red clouds roll rapidly through the sky, bathing the entire area in flickering ruby-colored light, and the wall lights give off only a dim glow. The trees are limp, and the shrubbery is a sickly yellow color. Jagged rocks litter the path ahead.

1c. Farhall

The walls of the cavern suddenly end in jagged raw edges. Before you is a vast expanse of rock. The red clouds swirl over the cavern. The trees stand stark and dead, stripped of their leaves. The bushes seem to reach out with their bare branches. More jagged-edged rocks block the path ahead.

2. Land's End

The trees and bushes end here, and nothing grows from here to the limit of sight in the distance. In places, the ground ends in a cliff that drops straight down, out of sight into more swirling clouds. Farther ahead, the winds carry the red clouds into a glowing storm of spinning clouds and rain, thunder and lightning. A wide path of rock winds between the cliffs and clouds, rounds the whirling stormcloud and goes out of sight.

In this area, the winds blow at MV 9". Characters who fall from the solid rock into the swirling clouds will be swept toward area Chaos (area 8) at MV 30".

3. Distance Distortion

The edge of this large area of stone drops off in the distance into the whirling clouds. The entire area is surrounded by a spinning tunnel of red clouds.

Here, the winds blow at MV 18". The laws of distance are changed from this point on, affecting PCs, NPCs, and monsters alike. Though the actual distance between figures is likely to change from turn to turn, the relative position of the figures does not change. This distance does *not* affect movement rate (MV), the range of missiles, the area of effect and range of

spells, or the size of things. It *only* affects the distance between objects on the ground or in the air. The distortion is due to the breakdown of the laws of the universe in the Black Abyss.

Detailed information on how to referee this distortion is given in the section on Expected Play. Only the Distance Distortion Table and quick reference notes are reproduced here for ease of play.

To determine what effect the distance distortion has, roll 1d8 and consult the Distance Distortion Table below. That table will give the amount of distortion, if any, for every hex in the Black Abyss during the next game turn (10 rounds).

Distance Distortion Table

Die Roll	Distance Change	New Map Hex Size
1-2	Everything is 10 times closer	1/10 old
3	Everything is 2 times closer	1/2 old
4	No change	Same
5	No change	Same
6	Everything is 2 times farther	2x old
7	Everything is 4 times farther	4x old
8	Everything is 10 times farther	10x old

First calculate the size of the map hex; before the first turn in this area, this will be 120 feet (12" wide). If the new hex-size is more than 1200 feet or less than 12 feet across, re-roll. Next, if necessary, calculate the distances between PCs, NPCs, and monsters; usually this will not be necessary.

It is important for you to keep track of the number of rounds that have been played since the last roll, so that the next roll will take place when scheduled *even in the midst of combat!* Distance distortion rolls will be needed every turn until the PCs get to the Island of Crystal (area 7).

4. Time-frame Distortion

As the swirling clouds move closer and farther away with the distance changes, you sense another, even stranger change. At first you think that the roaring winds and the strange lights from the clouds might be confusing you. But as things around you and time itself speed up and slow down, you know that the change is real.

From this point on in the Abyss, the laws of time also change. Distance in the area is still distorted, but now each individual PC, NPC, and monster may be moving slower or faster than usual, due to the time distortion effects here. This will affect movement rate (MV), ability to hit, and number of attacks.

Detailed information on how to referee this distortion is given in the section on Expected Play. Only the Time Distortion Table and quick reference notes are reproduced here for ease of play.

Keep running the distance changes as explained above. In addition, at the beginning of every turn, roll 1d6 and consult the Time Distortion Table below. This will give the relative time speed of the individual figure in question for the next turn (10 rounds), regardless what his relative speed was in the last turn. It will also give the modifiers to use when figuring number and success of attacks and movement.

Time-Frame Distortion Table

Die	Time	To Hit	#AT	MV
1	very slow	-2	/4	/4
2	slow	-1	/2	/2
3	normal	none	none	none
4	normal	none	none	none
5	fast	+1	x2	x2
6	very fast	+2	x4	x4

After the PCs have their first new time-frames, read this boxed description to the players with slower PCs. Remember, each character will think that he is the one moving unnaturally fast or slow.

Everything around you is moving unbelievably fast. The wind shrieks past you. The clouds are swirling in a blur. Other members of your party are moving so quickly that you can't keep up with them. Their voices sound high-pitched. They talk so fast that you can barely understand them.

After the PCs have their first new time-frames, read this boxed description to the players with faster PCs.

Suddenly some of the characters in this area begin to move in slow motion. You can move much faster than they can. You can barely understand them because they speak so slowly and their voices are a low rumble. The wind dies down and even the whirling clouds of the Abyss seem slower.

All characters moving out of this area toward the entrance will go back to a normal time-frame no matter what their time-frame was before leaving this area.

5. Magic Distortion

Suddenly there is a tingling feeling in the air. You can feel the hairs on the back of your neck rising. You shiver, even though you don't feel cold. The clouds glow brighter overhead, still casting their ruby-colored light around you. It is hard to tell with the roaring winds, but now the air itself seems to have a slight shimmer. More and more, the winds pull toward the cliffs.

The wind still blows at MV 18". From this point

on in the Black Abyss, the laws of magic also change. Spells may function in strange ways, or they may not function at all; spells intended to be cast may have effects that are totally different; magical items do not always work.

Detailed information on how to referee this distortion is given in the section on Expected Play. Only the Spell Distortion Table and quick reference notes are reproduced here for ease of play.

Keep running the time and distance changes as explained above. In addition, whenever a spell is cast, roll 1d10 and consult the Spell Distortion Table below. This will give the distortion effect. When a PC tries to cast a spell and a different spell goes off instead, do not tell the player which spell was really cast. Just describe the spell's visual effects and effects on the target.

Die Roll Effect

1-2	Random spell of same level cast
3	Random spell of next lower level cast
4	Random spell of random level cast
5	Random spell of random level cast
6	Spell does not function
7	Intended spell backfires against caster
8-10	Intended spell cast normally

Range, number and area affected, and duration are for the spell intended. Saving throw is for the spell actually cast.

Do not use the table for magical items used, including magical weapons and armor. Single-purpose magical items have a 50% chance of working every time they are used; the other 50% of the time they do not function magically, though a magical sword is still a sword and a shield is still a shield, etc.

Multi-purpose items will *always* behave magically. Half the time they will behave as expected. The other 50% of the time they will use one of the other magical properties chosen at random.

6. Breakdown

Before you, the solid ground gives way. Huge chands of rock break away from the edge and float off toward the center of the swirling storm. But the area is not losing its ground, because as soon as the rocks fall, new rocks form to take their place. There is a feeling of decay and rebirth at the same time here. You can barely hear over the howling wind and thunder of the storm. The glowing clouds become a huge whirlpool of red lightning and winds that spins down into blackness. Far in the distance, there is an island floating in the middle of the storm. It does not seem to be affected at all by the storm.

Keep running the distance, time and magic changes as explained above; there are no new

changes here. If the PCs watch the rocks that break away and fly into the storm, they will notice that all of the large pieces bump against the island before hurtling down into the whirlpool of the Black Abyss. Each large rock can safely carry one person to the island. Find the distance to the island using the current hex size.

7. Island of Crystal

This platform of giant crystals, flats in the center of the storm. All around the island, the whirlpool spins faster and faster before racing down into the chasm of the Black Abyss, but the air here is calm. The island and the air above it glow with a soft white light. In the center of the island, a miniature crystal minaret stands on top of a crystal base.

The moment each character steps onto the crystal island, the effects of the distance, time and magic changes stop for that character. The island is roughly triangular, about 100 feet on a side.

The crystal minaret is the treasure the PCs seek. Removing it from the base will cause the island to break apart, however, and it and everyone on it will plunge into the whirlpool storm surrounding the island. As they fall, the distance, time, and magic changes will start again. But the problem is not for the falling characters, but for those who remain behind, for the crystal minaret will transform the storm into a *teleport* of limited duration, as discussed in the description for Chaos (area 8).

Read the following boxed description when a character removes the crystal minaret. Do not mention the *teleport*.

As you pull the crystal minaret from its base, a horrible, loud rumble shakes the area. Putting the crystal back in its base does no good. The sound gets louder. The soft white light of the island starts to pulse and turns red. The winds of the storm move in to cover the island. The spinning clouds make it almost impossible to see. The crystals sizzle as red lightning strikes them. Suddenly, in a flash of light and a shower of flying crystals, the entire island explodes! Those on it fall into the whirlpool storm of the Abyss and disappear.

8. Chaos

As you fall at a terrifying speed, the wind blasts you in gusts. The glowing clouds all around feel damp and clammy. Ruby-colored lightning streaks past, barely missing you. You're being tumbled head-over-

heels into the center of the storm, still falling. The whirling clouds spin into a single hole of nothingness. There is no light, no dark, no time or space. The spiral storm spins toward the planes of the Abyss ahead. You feel yourself being pulled further into the Abyss, to be trapped forever.

Anyone falling into this storm before the removing of the crystal minaret destroys the Island of Crystal (area 7) will fall into the 666 planes of the Abyss.

After the crystal minaret has been removed, however, the storm will *teleport* the characters, their gear, and the crystal minaret back to the Return from Other Worlds (Crystal Prism area 7a). This *teleport* will last for 10 rounds only, and then any character that remains behind will be trapped here forever. During this 10 rounds, however, any character remaining who jumps or falls into the storm will be *teleported* back as well.

The problem is one for the players to figure out. There is no way to see the *teleport* spell work, for the visibility is so poor. Other spells may allow them to gain the knowledge that they should jump, but with the various distortions, this may be a matter of luck.

Mobius Tower Encounter Areas

Use Map 14-6 from the *Map Booklet* for play in this area. The sections on Background and Expected Play give information that will be useful in refereeing play here.

Mobius Tower Random Encounters

There are no random encounters in the Mobius Tower, though there are planned encounters in many areas.

1. Arrival

You find yourself standing in a 40-foot square room, dimly lit by torches on the walls. There is a stillness in the room; there is no sound or motion here. With a start, you notice that the dim flames in the torches do not flicker.

You are standing on a raised circular platform 20 feet across. To the south, a glittering object sits on a pillow. Four doorways lead out of the room, one near each corner of the room. The northeast door is open 2 feet. The southwest door is wide open, and the other two doors are closed.

None of the doors will move at all since they are time-trapped. The doors cannot be dam-

aged. The torch flames are hard and cold.

The glittering object is the crystal minaret that the PCs need. Finding it was easy. The crystal minaret and the pillow on which it rests, however, will not move through any physical means nor any magical means save a *teleport* spell to the Tower of Time (Level 4, area 26).

2. Apartment of the Firstwife

A large oval bed strewn with pillows is in the center of this 30-foot-square room. The figure of a woman dressed in royal robes sits on the edge of the bed, unmoving. She is inspecting a curved dagger blade. An ornate door stands open in the center of the west wall, and a curtain of beads blocks an archway in the east wall.

The woman looks elven, but evil and cunning, judging by the expression on her face. There is some sort of liquid frozen onto the blade of the dagger. The bead curtain cannot be moved; behind it are many fine clothes. The west door leads to a spiral staircase going up to area 20 of Level 2.

This woman was part of a plot against her husband, the sheik of this tower. She was imprisoned in this room for her plotting. Her spirit has become a groaning spirit that lives in this room.

The spirit will appear 1d6 rounds after the PCs enter and then speak in a moaning voice, saying: "For uncounted time have I sorrowed in these halls and now you, the living, come to torment me. Why do you curse me for my very thoughts?" She will attack immediately, using her keening wail 2d4 rounds after the start of melee. The keening wail will cause all within the room to save vs. death magic or die immediately.

Groaning Spirit: AC 0; MV 15"; HD 7; hp 22; #AT 1; D 1d8; AL CE; SA keening wail.

3. Closet

Behind the immovable bead curtain are many fine clothes within this 10-foot-square closet.

Even if the PCs can get through the bead curtain, which cannot be damaged or broken, everything here is time-trapped and will not move.

4. Guard Room

This small 20-foot-square room has two arched doorways, one in the south wall and one in the east wall. Four large, muscular figures stand at attention along the west wall, apparently guards. Their faces are masked by turbans, and they wear robes. They have large scimitars at their sides.

The eastern doorway leads to a spiral staircase that goes down or up to area 26 of Level 4.

5. Sheik's Apartment

A heavily hooded figure with a bow stands in the partly-opened south door of this room. In the room before him, rich drapes hang like iron over a comfortable looking, but rock-hard bed. Lying peacefully asleep on the bed is a handsome man of the desert. Suspended in the air just a few inches from the sleeping figure, an arrow is trapped in its flight straight toward the sleeper's heart.

Everything in this room is time-trapped. There is just enough space between the assassin and the doorway for the PCs to squeeze through. The arrow cannot be moved or broken, though something owned by the PCs may be placed in front of the arrow's path to deflect it.

6. Cloak Room

The walls of this 20-foot-square room are lined with pegs on which handsome robes hang. A tall man in rich white robes stands against one wall of the passage-way leading off to the east. Half-hidden by the open curtains at the passage opening, he faces the archway in the west wall. An archway in the south wall leads to a spiral staircase leading up and down.

The white-robed figure appears to be the skeletal remains of a human. It is a cryptknight, who, while helping to assassinate the Sheik, was killed at the exact moment the Tower became time-trapped. It will attack the first party member to enter the room in front of him or the corridor behind him. He holds a wicked-looking dagger in his hands, which can be seen from the doorway from the Sheik's Apartment (area 5) though it is concealed and cannot be seen from the doorway to area 8. The south archway leads to the Longstair (area 7).

Cryptknight: AC 0; MV 12"; HD 9; hp 50; #AT 1; Dmg 1d4; AL LE; SA emanates continual fear.

7. Longstair

This ornate spiral staircase leads both up and down. Visibility is limited to about 5 feet up and down because of the curve of the walls.

This staircase connects all of the levels of the Mobius Tower. It is in a magic loop, going up and down past the same levels forever. Thus, if one climbs this staircase from Level 1, the next level to be encountered would be Level 2, then

Level 3, Level 4, and finally Level 1 again. In a similar way, descending from Level 1 brings Level 4, then Level 3, Level 2, and finally Level 1 again.

8. Feasthall

A long, low table fills the center of the room. Pillows are strewn all about, most of them at the western end of the table. A servant stoops over the table pouring a red liquid into a goblet on the table. The liquid is frozen in mid-air, half-way to the goblet. There is a doorway with its curtains pulled back in the east wall. A partly open door leads out through the north wall, and an archway in the west wall opens onto a hall going north.

9. Buffet

Tables line the east and west walls of this 20-foot by 30-foot-wide room. Open archways lead from the centers of the north and south walls. The motionless figure of a servant girl stands in an eternal blush. Her hand is trapped in a slap across the face of a surprised fat man dressed in rich robes and a turban.

10. Kitchen

This is a kitchen. Lush and wonderful foods of every kind you can imagine lay on the counters. But all the food is rock-hard, tasteless and odorless. Archways lead from the north and south walls. There is a closed door in the east wall.

11. Pantry

Rough shelves line the west wall of this 20-foot-square room. Meat hooks with quartered beasts hang from the ceiling. The meat looks appetizing, but it is stone-hard. Two cooks kneel motionlessly with their ears pressed against a closed door on the east wall. They seem to be trying to hear some sound through the door. There is an open archway in the south wall.

There is a 1-inch open space under the door in the east wall. From underneath can be heard the tinny sound of glass against stone.

12. Bottleroom

This 10-foot-wide room is 20 feet long. It appears to be empty except for one thing. A small glittering bottle on the floor rocks rhythmically.

A djinn was imprisoned in the bottle ages ago, brought here by some hapless adventurer. Though the adventurer is long gone, the djinn remains, but will not be encountered until the bottle's stopper is pulled. Neither the djinn nor the bottle are time-trapped.

The DM can allow the PCs the use of this djinn without concern particularly if they have not yet encountered the efreet in the Lost Hall (Level 2, area 16). If the djinn is not imprisoned when the efreet there is discovered, and the DM can attempt to play the djinn in such a way that this occurs, the djinn will battle the efreet in a miniature of the battle that rages between Khalitharius and Aeraldoth.

Djinn: AC 4; MV 9"/24"; HD 7+3; hp 22; #AT 1; D 2d8; AL CG; SA and SD magical abilities.

13. Procession

This very ornate room has many carved pillars of beautiful design and workmanship lining the walls. The room is octagonal in shape and 40 feet from side to side. It is dimly lit by unmoving torch flames on the walls. A grand staircase, 20 feet wide, leads up to a platform on the east wall. Archways lead from the north and south walls. A curtain covers a 20-foot-wide opening in the west wall. Several turbaned men stand on the stairs convulsed in motionless laughter.

14. Skeleton

Several dark-faced men and oval-eyed women wearing gay and bright clothing stand in this room. They look as though they are laughing, but there is no sound or movement. A small figure in drab clothing squats in the northwest corner of the room.

The small figure in the corner is a skeleton in ancient and rotted clothing. The skeleton is armored and has a backpack under his rotting robes. In the backpack, there are 400 pp and 3 gems worth 500 gp each.

15. Room of State

This dark room is octagonal in shape and 30 feet across. Open doors lead from the east and west walls. An open sarcophagus lies in the center of the room.

A mummy, which cannot be seen from either door, will leap from the sarcophagus as soon as the room is entered.

Mummy: AC 3; MV 6"; HD 6 + 3; hp 23; #AT 1; D 1-12; AL LE; SA fear attacks.

16. Lost Hall

Using the map, describe this hall to the players. The efreet who stands guard in the centermost section of the Hall is not time-trapped and will attack at his first chance. He guards a *staff of teleportation* that hangs on the wall.

The staff has five charges and will only teleport single items of less than 200 gp weight. It is used for moving small items conveniently. The staff's user must picture in his mind where he wants the object to go and then touch the tip of the staff to the object. Remember that nothing can be teleported out of the Mobius Tower except via the Tower of Time (Level 4, area 26).

If the djinn from the Bottleroom (area 12) is in service to the efreet, it will do the combat honors, as given in the description for that Encounter Area. If the bottle containing the djinn is in the possession of a PC, that PC will be attacked first, as the efreet attempts to take the bottle. The efreet will *not* fight to the death. Instead, it will escape when down to 8 hp, and lie in wait for the PCs elsewhere.

Efreet: AC 2; MV 9" / 24"; HD 10; hp 32; #AT 1; D 3d8; AL N (LE); SA magical attacks.

17. Harem

This 30-foot-diameter room is dimly lit by motionless flames from torches on the walls. Unmoveable curtains hang from the ceiling. There are pillows and couches strewn about the room. Beautiful women lie still as stone in poses of relaxed laughter. An arched exit to the north is open with tied-back curtains. A doorway to the west is closed.

18. Harem Guard

Two huge figures stand in this 20-foot-square room. Their faces are wrapped in cloth, their eyes almost hidden in the shadows beneath their helmets and turbans. They stand ready, swords in their gloved hands. Archways are open in the north and south walls. A wooden door in the west wall is partly open. A door in the east wall is closed.

19. Guardroom

This 30-foot-long hallway is 20 feet wide. Three 10-foot-wide cells open from each side, in front of which 6 huge figures, their faces shrouded by robes, stand at attention.

The figure of another huge man lies on the floor, his robes draped loosely over his body. An open door hangs motionless in the east wall. An open archway leads from the west end of the hall. The room contains a noticeable stench.

The figure on the floor, from which the stench rises, is the skeletal remains of the long-dead Captain of the guard. Characters that touch his clothing will notice that it is moveable. Moving his robes will bring the Captain's ghost rising from the skeletal body. It will only attack if the party attacks it immediately. Otherwise, it will speak one round after appearing.

If given the chance, the ghost will explain that he was Al-Dolak, the once-great Captain of the guard. He was involved in the assassination plot against the Sheik, but had only a coward's role to play. He assembled the guards for inspection just as the assassins were attacking the Sheik. Now he must stay here, looking upon their noble faces.

Ghost: AC 0/8; MV 9"; HD 10; hp 30; #AT 1; D 1d4 + 10 years aging; AL LE; save vs. spells else damage and flee in panic.

20. Treasury

This room is 30 feet wide and 40 feet long. There are open archways in the center of the north and south walls. A curtain blocks a 20-foot-wide hole in the east wall. There is a 10-foot-wide iron door in the center of the west wall. Three guards, with their swords drawn, stand on each side of the room. Two other guards are frozen in mid-stride as they race for the north doorway. Three strange figures stand with swords drawn to block the running guards' way.

The three strange figures are cryptknights, who will come to life and attack the party after they enter the room. The iron door is open 1/8 of an inch. Through that crack a 20-foot-wide by 10-foot-deep empty room can be seen.

3 Cryptknights: AC 2; MV 12"; HD 8; hp 31,29,26; #AT 1; D 1-6; AL LE; SA emanate continual fear.

21. Orchestra

Across from the open archway leading into this room there is another open archway 20 feet away. The room is 50 feet wide. To the east, there are several figures sitting motionless, time-trapped while they played their ancient instruments. Stairs, the width of the room, go up to the west wall, like bleachers.

22. Northern Hall

This grand hall is stopped in timeless grandeur. Men dressed in bright robes of various colors sit about the room on pillows in attitudes of talk and laughter, though there is no sound. In the center of the room, 20 dancing girls, clothed in bright robes with veils over their faces, hang in timeless spins.

23. Southern Hall

This grand hall is stopped in timeless grandeur. Men dressed in bright robes of various colors sit about the room on pillows in attitudes of talk and laughter, though there is no sound. In the center of the room, 20 dancing girls, clothed in bright robes with veils over their faces, hang in timeless spins. The unmoving figure of a man dances with one of the girls.

The dancing figure is an adventurer who died here long ago. If touched, his robes will fall away, his skeleton crumbling slowly with it. Hidden in the folds of his robes is a map that leads to the pillar in the Tower of Time (Level 4, area 26). On the map is a note saying "The way back".

24. Preparation

This 20-foot-square room is brightly lit by torches on the wall that flicker and flail in the air. A pair of bronze doors stands closed before you.

Neither the doors nor the torches are time-trapped. Thus, the doors will swing open if the characters push them.

25. Audience Chamber

This ancient throneroom is lit by the flickering light of fiercely burning torches stuck into the walls and the 12 thick pillars that support the roof. A lone figure shifts its weight upon the throne at the far side of the hall, 50 feet away. About his neck, the figure wears a large medallion of intricate design.

The figure is one of the Guardians of Time, who is living here in the Mobius Tower for a short while as an amusement. (Who knows what a "short while" might be for a guardian of Time?) He will give this clue for getting out of the Tower to the PCs:

Up continues ever up
And down continues down.

The tower built by Mobius
Is one eternal round.

But if you wish to leave this place
Of endless cheer and woe
Think of the times before you came
And thither you must go.

He is wearing the *Medallion of Time*, which he will not give up without a fight. This medallion works in a power field that is generated by the pillar of light in the Tower of Time (Level 4, area 26), and so it has no magical value outside the Mobius Tower. Inside the tower, however, this medallion gives the person who wears it the power to change the time-frame of anything within the tower to his own time-frame. This means that the person wearing the medallion can release anything that is time-trapped, even people.

The medallion can only release one thing at a time, and will only work three times each week. Anything that is released by the medallion will stay released forever. Outside the Tower, the medallion is worth 5,000 gp; to those inside the tower, it can be priceless.

Guardian of Time: AC -2; MV 12"; HD 12; hp 66; #AT 1; D 1d12; AL LN.

26. Tower of Time

This vast room is lit by globes of bright light that hang from the 100-foot-high arched ceiling. This room is an octagon 80 feet across with curtained archways on alternating walls.

In the center of the room and rising to the ceiling stands a 20-foot-square pillar of crystal, glittering light flashing up and down its four sides. The pillar stands on a large and ornate base 15 feet tall. Within the base are two 10-foot-tall archways, one on the north side and one on the south. Each is blocked by a shimmering curtain.

A tapestry hangs on the northeast wall. It is a picture of the central chamber in the crystal prism, complete with the model of the Citadel of Martek.

Nothing in this room is time trapped, and anything transported here will be brought to the time-frame of the PCs.

There is an alcove behind the shimmering curtain in the north archway in the base. Within, a 3-inch-wide hole in the roof streams light down to a similar hole in the floor. The glittering light looks like and behaves like a liquid. It will spray about and splash if it is touched or disturbed, but it cannot be felt.

It is the power source for the *Medallion of Time* about the neck of the Guardian of Time in the Audience Chamber (Level 3, area 25). It is also the power source for the time-trap that

permeates the Mobius Tower. If either hole is completely plugged, and no light leaks out at all, everyone and everything in the Mobius Tower will suddenly come to life. The tower will stay in the PCs' time-frame for as long as the hole is plugged. Pressure will build up behind the plugged hole, however, forcing out any plug within 2d6 rounds. The moment the light starts to flow again, the tower will become time-trapped again. Anything that disturbs the flow of light from the ceiling of the alcove to the floor will cause time to pass everywhere in the Tower. The arrow poised at the heart of the Sheik will fly forward, and so forth.

Behind the shimmering curtain in the archway on the base's south side is a 5-foot-square alcove. Within a 2-foot-square hole in the back wall of this alcove is an hourglass on a frame. The hourglass can be turned over, but it cannot be taken from the hole.

When the hourglass is turned over, time will start going backwards irreversibly for the PC. They will suddenly feel swept off their feet. For the next few minutes, they will see everything that happened to them while they were in the Tower happening again, except backwards, like a sped-up movie in reverse. Comrades that died in the Tower will spring back to life and join the party. This will continue until they see the moment they first arrived in the Tower. Then, they will be teleported back to the Return from Other Worlds (Crystal Prism area 7b). Everything that is in the Tower of Time when the hourglass is flipped over will also be teleported with the PCs, though nothing that was once time-trapped will be. Characters who are brought back to life will have the same hit points and powers they had just before they were killed.

27. Blank

This 20-foot-square room is dust-covered and appears empty. There is a door in the north wall.

The room is empty.

28. Tome of Time

In the center of this 20-foot-square room is a wooden stand, atop which lies a large book.

The book is the *Tome of Time*, which may be handled by PCs of any alignment or character class. Its cover is made of platinum plates. It contains the following spells: *haste*, *slow*, *dimension door*, *distance distortion*, *passwall*, *teleport*, *disintegrate*, *limited wish*, *permanent*, *temporal stasis*, *time stop*. It is worth 20,000 gp.

Desert of Al-Alisk Encounter Areas

For play in this area, use Map 14-7 from the *Map Booklet*. The sections on Background and Expected Play give other information helpful to play here.

Desert of Al-Alisk Random Encounters

There are no random encounters in this area. Refer to Lancers of Death (area 3) for the encounters that occur there nightly.

1. Crystal Obelisk

Read the following when the PCs arrive at this place, either for the first time or because they have been teleported here by going off the map.

Suddenly you find yourselves standing beside a crystal obelisk 10 feet tall. The runes on its sides reform themselves to read "Touch me to the crystal minaret, and I will bear you home." There is a stillness here, unusual even for the desert. Not even a puff of wind stirs the air.

Read the following immediately if this is the first time the PCs have been to the Crystal Obelisk. This description, or one like it, should be given to the players when the PCs ask what they see from any map location where there is no other description.

Stretching to the limits of sight, the sand dunes of the desert roll into the distance, baked by the blazing sun. Not a single stone shows through the glittering grains, nor does a single insect scurry across its surface. In every direction, the burning silence of the sand-sea is oppressive and forbidding. The sun beats down like a golden hammer on this parched land, the crescent shapes of the dunes marching into infinity in all directions. Such landmarks as might be visible are hidden behind the shimmering desert air.

2. Edge of the World

This area appears like any other part of the desert. Whenever the PCs move off the Desert map (Map 14-7) into this area, however, they will be instantly teleported to the Crystal Obelisk (area 1). Read the boxed description for the obelisk at that time.

3. Lancers of Death

The shaded area on the map is just like any other area, except that, at midnight the PCs can be witness to one of the special encounters

described below.

On the first night that the PCs spend in the area, one of them will see and hear a spirit. Randomly select a PC that is awake just before midnight. If the PC is of good or neutral alignment, use the first boxed description below. If that PC is of evil alignment, use the second boxed description below.

Vision for good or neutral PC.

The starlight in the clear night sky seems to change into a beautiful oval face with large, soulful eyes. A voice sings in the wind calling your name and pleading for help. She says:

I am Sithal Al-Husn, a daughter of the Pazar dynasty. I beg you to listen to the pleading of my case. My father, the Sultan, did marry me to the man of my love, Atas Al-Din. I was to be presented to him one great and beautiful night.

On my wedding night, from the shadows of the street, I was stolen by a man whose heart had been smitten by my looks. I had no feelings of warmth for him. He carried me away into the desert. I now await the coming of my father's lancers with my love, Athis Al-Din, at their head. But my captor is strong. Please free me from my imprisonment.

The vision fades, and her face dissolves back into the stars.

Vision for evil PC.

The starlight of the clear night sky fades into darkness. A man's red and terrible face appears, saying:

I warn thee and all with thee. Get thee hence from this land. The battle to come is between me and Athis Al-Din and none of thy concern. If thou values thy life, get thee hence.

The face disappears into the night sky, and the starlight returns.

Every night after the first that the PCs spend in the area, they will see the Lancers of Death riding in an unending stream 500 feet above the ground. These appear to be thousands of armed warriors in desert garb, mounted on stallions whose hoofbeats sound like the roll of distant thunder through the night. The first appears at midnight, and the stream continues uninterrupted until 3 am. They completely ignore the party as they stream toward the

entrance to the Crypt of Al-Alisk (area 5). They are easily followed.

4. Death Watch

As you approach this area you get an uneasy feeling. From the top of a dune, you see slight movement ahead, like something blowing in the wind. But the air is still. Looking carefully, you see the movement again. The robes of a line of almost invisible creatures rustle in a wind you don't feel. The line of guards stretches over the sands for as far as you can see. There must be thousands of them.

The guards are spectral minions of Al-Alisk, who guard the Crypt (area 5); all are armed with swords. The PCs must destroy at least 20 of them to break through their lines. Between midnight and 3am, all of these guards will fly up into the air and battle the Lancers of Death (see area 3 above). At that time the PCs can pass through this area unmolested.

Spectral Minions: AC 2; MV 16"; HD 6; hp 6d6; #AT 1; D 1d8; AL NE.

5. Crypt of Al-Alisk

In this hilly area, low rock outcroppings show weathered carvings, obviously made centuries ago. These carvings have been almost worn away by the sands and winds of the desert. A flight of stairs, cut from the standing rock, leads up to a large cave, in the mouth of which stand pillars.

For further play in this area, use Map 14-8 from the *Map Booklet* and the descriptions found in the *Crypt of Al-Alisk Encounter Areas* below.

6. Ruins of Akhir

The desert sands stand still over the broken remains of a once-great city of the desert. Most of the buildings are buried or have crumbled away.

The DM can expand this adventure by designing this city and letting the PCs explore it. For the players' sakes, it should not detract too much from the play of this adventure. Remember not to do anything that will make it more difficult for the PCs to finish their quest. Still, don't make it too easy or the players will not take it seriously. They (the players) should have the wisdom not to become sidetracked from their mission, even if their PCs do not.

Crypt of Al-Alisk Encounter Areas

For play in this area, refer to Map 14-8 in the *Map Booklet*. This Encounter Area corresponds to Desert of Al-Alisk area 5 on Map 14-7. The sections on Background and on Expected Play have further information that is useful in judging play here.

Crypt of Al-Alisk Random Encounters

Every three turns roll 1d6 to determine if a random encounter takes place. On a roll of 1 or 2, one does. Roll 1d4 and consult the table below to determine the nature of the encounter.

Crypt of Al-Alisk Random Encounter Table

- 1d4 + 4 Spectral Minions: AC 2; MV 30"; HD 3; #AT 1; D 1d8 or Nil, see note; AL NE. There is a 20% chance that these will be unarmed; armed minions will have swords.
- 1d10 Spectral Minions: AC 2; MV 30"; HD 3; #AT 1; D 1d6 or Nil, see note; AL NE. There is a 20% chance that these will be unarmed; armed minions will have short swords.
- 1d6 + 2 Wights: AC 5; MV 12"; HD 4 + 3; #AT 1; D 1d4 + energy drain; AL LE; SA hit drains 1 level; SD +1 weapons or better needed to hit.
- 2d4 Wraiths: AC 4; MV 12"/24"; HD 5 + 3; #AT 1; D 1d6 + energy drain; AL LE; SA hit drains 1 level; SD +1 weapons or better needed to hit.

1. Entry Cave

Within this vast cavern, carved stone pillars extend to the ceiling, looking as though they have been fitted in place. The back of the cave is walled off with fitted masonry stone, and double doors of stained metal open into its center.

When the doors are opened, the skeleton of a long-dead adventurer will fall out as if it had been leaning against the door from the inside. There are marks on the inside of the door from his attempts to claw his way out.

2. Catacombs

There is a musty smell in this area. A 10-foot-wide hallway runs between large catacomb vaults that rise 30 feet to a flat ceiling. Four vaults stand on each side of the hallway, with 10-foot-wide spaces in between. There is an uneasy feeling about this chamber.

There is a 10% cumulative chance per round that the PCs will hear a low, almost silent, moaning, like the wind crying. It comes from 5 spectral minions who live here. As soon as they are heard, the spectral minions will appear as vague, wistful spirits, flying about and between characters, and soaring about the room as they moan. These monsters have no weapons, and so they cannot do any physical damage. But their moaning has an unnerving effect, causing fear unless a save vs. spells is successful. Characters who fail their saving throw must exit the crypt in panic, running away blindly for 3 rounds. If they return, they must make another save at a penalty of -4 to the roll.

As soon as the party reaches the middle of the hallway, between the second and third pairs of vaults, read the following.

From the far vault on the left-hand side appears an insubstantial figure wearing ancient robes of royal design. It points a finger at you and speaks in a hollow but thunderous voice, saying:

Get thee hence from mine own dominion. None shall look upon her grace and beauty save me alone.

This is the spectre of Habrauk Al-Nirin, who stole the princess and locked her up here. It will attack as soon as its speech is ended.

Spectre: AC2; MV 15"/30"; HD 7+3; hp 45; #AT 1; D 1d8 + energy drain; AL LE; SA hit drains 2 levels.

3. Hall of Mourning

Within this 30-foot-square room, bronze double doors stand in the center of the opposite wall. In the center of the room, there is an altar with a black cloth over its top.

4. Entry Room

Two bronze doors lead out of this 20-foot-square room. Cobwebs hang from the corners near the ceilings.

5. Spirits Room

Within this 30-foot-square room, bronze double doors stand in the center of the opposite wall. In the center of the room, there is an altar with a black cloth over its top.

Identical in appearance to the Hall of Mourning,

this area is to confuse tomb robbers. The doors on the far wall are false. Within the room is a groaning spirit.

Groaning Spirit: AC 0; MV 15"; HD 7; hp 27; #AT 1; D 1d8; AL CE; SA wail causes death unless save vs. death magic is made.

6. False Entry

Two bronze doors lead from this 20-foot-square room. Cobwebs hang from the corners near the ceiling, and statues stand near the far doors.

The statues are really adventurers turned to stone by the cockatrices in the next room.

7. Cockpit

Within this 30-foot-square room, bronze double doors stand in the center of the opposite wall. In the center of the room, there is an altar with a black cloth over its top. Five small birds strut about the room.

The "birds" are cockatrices, who will attack from the center of the room as soon as anyone opens the door. The far doors are false. Except for the cockatrices, this room is identical in appearance to the Hall of Mourning (area 3).

5 Cockatrices: AC 6; MV 6"/18"; HD 5; hp 23,21,19,19,17; #AT 1; D 1-3; AL N; SA Petrification.

8. False Mourning

Within this 30-foot-square room, bronze double doors stand in the center of the opposite wall. In the center of the room, there is an altar with a black cloth over its top. The bones of a minotaur and those of a human in chain lie in the center of the room, locked in what must have been combat to the death.

9a-9d. Revolving Tomb

Through a 20-foot-long section of corridor you see a brilliantly lit room behind a crystal column centered at the corridor's end. The column blocks any view of the room beyond.

To get to the Crystal Tomb (area 11), the PCs must pass through invisible teleports. The PCs can see through these teleports, but they cannot hear through them. Anyone entering the tomb through one of the four areas 9a-9d will exit through the areas 10a-10d, thinking they have walked down a straight 20-foot corridor.

In reality, they have been teleported as shown by the table below. These teleports, combined with the identical appearance of the surrounding rooms, with their monsters and false doors, were built to confuse tomb-raiders.

Tomb Entry Teleport Table

Enter	Leave
9a	10c
9b	10d
9c	10a
9d	10b

10a-10d. Tomb Exit

Through a 20-foot-long corridor, a crossing passageway can be seen. Double doors stand at the end of the corridor, directly across the passageway.

Exit from the tomb does not activate the teleports, and the corridors act just like normal corridors. Thus someone exiting from 10a will come out at 9a, just as shown on the map.

11. Crystal Tomb

In the center of this 30-foot-diameter room, rising to the domed ceiling 20 feet overhead, four crystal pillars stand around a crystal cylinder 10 feet in diameter. Behind the pillars, four arched corridors lead out to a corridor beyond.

Within the cylinder, a young woman kneels, her pleading face turned upward, a tear half-way down her cheek. Her lovely oval face is set off by her large dark eyes and her long, slender neck. Silken hair sweeps down to the waist of her wedding veils.

At her knee sits a brass ball of curious and intricate workmanship. About her neck hangs a delicate necklace of gems. A small crystal minaret on the pillow on which she kneels is almost concealed by the veils about her.

The only way to release the princess is to shatter the crystal pillars, for the cylinder in which she kneels is unbreakable any other way. When all four surrounding pillars are broken, the crystal cylinder will shatter of its own accord. Each pillar will withstand 20 damage points before breaking. If the PCs release the princess, read the following description.

As the crystal shards cascade to the floor, the figure of the princess within crumbles to dust with a sighing sound. A heartbeat passes. Overhead, the air glows blue and forms the soft lines of a beautiful face with dark, almond eyes. It is the princess. Her

mouth does not move, but her voice, like the rustle of an evening breeze, says before her face fades once again:

Thou hast freed me. Now I shall rise to meet my beloved, and we shall live in the worlds to come, with love and peace. Take what thou wouldst. All my worldly goods do I offer to thee.

The brass ball is a *liahona*, an intelligent compass that will react for Lawfully Good aligned characters only. It uses limited telepathic abilities to give the direction of north to its user. It also works as a *locate object* spell once per day, and will answer one yes or no question once per week. It is worth 10,000 gp.

The diamond necklace is worth 3,000 gp. The crystal minaret is what the PCs seek; it is part of the model in the Crystal Prism.

Once freed, Princess Sithal will join her beloved, Athas-Al-Din, in Heaven Westward, and the Lancers of Death will not appear again.

Inner Sanctum of Martek Encounter Areas

Inner Sanctum Random Encounters

Martek's Inner Sanctum is watched over by the Guardians of Nephthys, an army of protectors set here for this purpose only. Roll 1d6 for random encounters once every three turns. On a roll of 1 or 2, roll 1d12 and consult the Inner Sanctum of Martek Random Encounter Table below to determine what the encounter is.

If the PCs are openly displaying any of the Star Gems, none of the Guardians will attack, being content to watch the PCs suspiciously. If the PCs attack the Guardians, the monsters will retaliate.

Inner Sanctum of Martek Random Encounter Table

- 1-2. 2d8 Spectral Minions: AC 2; MV 30"; HD 3; #AT 1; D 2d10; AL LN.
- 3-4. 1d6 Cryptknights: AC 0; MV 12"; HD 9; #AT 1; D 1d12; AL LE; SA emanate continuous fear; SD +1 or better weapons needed to hit.
5. 1-3 Sphinx: AC -2; MV 18"/30"; HD 12; #AT 2; D 2d6/2d6; AL CG; SA 3 roar attacks per day, first as *fear* spell, second deafens, and third drains strength.
6. 2d12 Poisonous Snakes: AC 5; MV 15"; HD

4 +2; #AT 1; D 1-3; AL N; SA save vs. poison or die.

7. 2d8 Giant Tarantulas: AC 6; MV 18"; HD 2 +2; #AT 1; D 1d4; AL N; SA save vs. poison or be paralyzed.
8. 2d6 Giant Scorpions: AC 3; MV 15"; HD 5 +5; #AT 3; D 1d10/1d10/1d4; AL N; SA save vs. poison or die.
9. 3d6 Mummies: AC 3; MV 6"; HD 6 +3; #AT 1; D 1d12; AL LE; SA save vs. spells or else fear; touch causes disease.
10. 1d6 Necrophidius: AC 2; MV 9"; HD 2; #AT 1; D 1d8; AL CE; SA save vs. spell or else hypnotized paralysis.
11. 1d4 Cockatrices: AC 6; MV 6"/18"; HD 5; #AT 1; D 1d4; AL N; SA touch turns to stone.
12. 1d8 Ghosts: AC 0/8; MV 9"; HD 10; #AT 1; D special; AL LE; SA touch ages 10-40 years; ethereal, magical attacks.

1. Entry Hall

Three flights of broad steps climb this great and majestic hall, rising to a pair of huge golden doors beautifully carved with delicate care. Clear water dances from a fountain on the first landing. The cool waters give a freshness to the air. Open corridors lead off to either side on the second landing. One of the golden doors hangs slightly open.

The fountain waters act like a *potion of extra healing*, restoring 3d8 +3 hit points to any character who drinks it. The waters will give this effect only once per day for each character, and they may not be removed from Martek's Inner Sanctum without Martek's permission.

2. Vault of Martek

In the middle of a vast dark area, a single pillar of light shines down from an immense dome overhead. The shaft strikes the top of a round platform, 20 feet above the floor. Stairs rise up the sides of the platform to the skeleton of a man, bathed in the brilliant light. The bones are laid out so that the feet point toward the east and the skull to the west. On the skull is a metal headpiece that reflects the light into three beams, each of which strikes a great statue. The room is hushed.

Once the eyes have adjusted to the gloom, it is possible to see that the room is circular, 160 feet across. The domed ceiling

is 100 feet above the floor. Four sets of golden doors lead from the room to the four points of the compass. A small, dark figure is hunched against the north set of doors.

Each of the statues stands 30 feet tall and appears to be of a giant djinn wearing a high turban and holding a giant scimitar before him. There is a hole in the front of each turban, as if it were the setting for a very large gemstone.

The bones are those of Martek, which are guarded by four cryptknights. The cryptknights will not attack if the PCs are openly displaying any of the Star Gems. All the doors are unlocked.

4 Cryptknights: AC 0; MV 12"; HD 9; hp 50,24,39,38; #AT 1; D 1d6; AL LE; SA continuous fear; SD +1 weapon or better needed to hit.

The hunched figure at the north door is dead. If Trifakas, Sardok, or Pawnis got here before the PCs, it is he; otherwise it is a slave. The unfortunate died of a heart attack upon gazing at the treasure behind the doors.

Three of the Star Gems are meant to be placed in the turbans of the statues. The other two will fit in sockets in the east and west sides of the platform's top step, one at the head of Martek's skeleton and one at the foot. When the five Star Gems are placed in the sockets (the order does not matter), Martek will come back to life. In this case, read the following description.

As the fifth and last Star Gem is placed, a dull throbbing starts to build. Suddenly, with the sizzling sound of lightning, the pillar of light splits into three beams from the ceiling. Each beam shines on one of the Star Gems in the statues' turbans. These reflect the light to the other statues, forming a pyramid of light about the platform, which pulsates to the rhythm of the throbbing sound.

A crack like thunder fills the room, and two more beams of light shoot down from the ceiling, striking the Star Gems at the skeleton's head and foot. These bathe the bones in reflected beams, playing over them with ever-increasing speed. The throbbing increases to ear-deafening pounding, and a keening moan of rushing wind begins to build sending shivers down the spine.

The ancient bones stir, and then, in a brilliant flash from the gems at its head and feet, the skeleton rises and spins into a blur. When the spinning stops, a live man stands upon the platform. Though dressed simply and now crownless, his gentle face and welcoming gestures tell you that he is Martek, returned from the dead.

Martek will thank the PCs, wondering what took them so long. He will state that he has some moments before he turns to the problem of Khalitharius, who he will banish forever from this place. If asked, he will tell the PCs that his Sphere of Power is his knowledge and wisdom, and that the centuries must have shrouded this in legend.

Martek will give the party a tour through his Inner Sanctum, showing them the libraries (areas 3 and 4) and his treasury (area 6). He will offer each PC three items from his libraries and treasury in thanks for their courage and determination, allowing the PCs to choose from the magical items that are there or from his treasure, including the Star Gems.

When all have made their choices, he will say that the time has come when they must depart and he must finish his task. He will take them to either Transdimensional Door (area 5) and activate it for them. Only after they have left will he leave himself.

When the PCs have stepped into the door, the following may be used to conclude the campaign.

A brilliant flash surrounds you as you step into the wall. Blindingly white light softens to a blue color. You are in a bubble of soft glass, turning slowly. Nearby, you see the other members of your party, in their own bubbles, also floating through a blue mist. Martek's strong and powerful voice speaks into your mind:

Behold the prophecy fulfilled. Look upon the fruit of your courage and determination.

The blue mists start to change into sky. The vast Desert of Desolation stretches out, 1000 feet below you. Your sphere flies quickly toward huge billowing clouds on the horizon. After only a breath, you are in those clouds, safe within your floating sphere.

The clouds suddenly part. You are floating above the center of a raging battle storm. Aeraldoth, the Djinn Vizier, stands like a giant on the desert sands. His upstretched arms command a gale of wind and ice. Not far from the djinn, the evil Efrete Pasha Khalitharius calls down wave after wave of flame and lightning.

A small figure appears suddenly between the efrete and the djinn. It is Martek. Robes flowing in the wind, Martek taps his staff upon the ground three times. Three thunderclaps, like voices of doom, ring across the desert. The wind and flames stop. The efrete looks down at Martek in surprise and fear. Martek speaks, saying:

Khalitharius I call they by the power

in thy name This day of thy doom was prophesied. So shall it be.

The voice of the efrete rumbles like distant thunder, replying:

Martek! Are you here now or is this but another of my fears come to me in a dream? Leave me to my vengeance!

Martek answers calmly, saying:

Nay, efrete, no mere bottle for thee this time. Thou hast wasted thy powers upon the desert and this good djinn. Thou hast nothing left to fight my command!

The efrete raises his arms in anger and fear. His horrible screech pierces the clouds. Martek, too, raises his arms. As Martek speaks again, the fiery efrete bursts into a million streaks of flame, darting madly through the wind. A horrendous crash of wind and thunder throws desert sands about your bubble, blocking your vision. Your bubble is moving again, and the desert sky is changing into the soft blue mists once more. Martek's voice comes to you again:

The desert is returned to its people; the efrete is no more. One final gift I give to you, though you may not feel it a true one. Those people whom you have met on this quest will remember thee no more, and you are free to travel the face of this world as you want, making thy way with no prior prejudice. All to whom you tell this tale will believe it to be but a fable. Only you shall know the truth of what you have seen. There are other prophecies to be fulfilled. Farewell, my friends.

The blue mists flash into white, blinding you for a moment. Then the sphere of glass is gone. You have arrived in the place pictured on the wall in Martek's Inner Sanctum.

3. Tomes of Martek

In this open area, 30 feet by 60 feet in size, the walls are lined with shelves. On the shelves are books, tomes, and ledgers. On a table in the center of this area, a book lies open.

The book on the table is titled *Martek, By Martek*. The writing on the open page reads:

All my life have I spent in the acquisition of knowledge and the refinement of my wisdom. This wisdom and intelli-

gence is not all-powerful, nor does it extend to the ends of the universe. It is but a sampling of all that is to be had. Such is the realm of my wisdom, the sphere of my power. Those that follow must recall me to fulfill their quest. To this end were the Star Gems hidden.

The PCs may search the shelves for books that interest them, though none may be removed from the library without Martek's permission. For every turn they search without Martek's aid, roll 1d10. On a roll of 10, a magical book has been found; on all other rolls, they find only non-magical books. Use the tables below as a guide to the books that are available.

Magical Books Table

Roll	Title
1	<i>Book of Infinite Spells</i>
2	<i>Libram of Gainful Conjuraton</i>
3	<i>Tome of Clear Thought</i>
4	<i>Tome of Understanding</i>

Non-Magical Books Table

Roll	Title
1	Orc Stew and Its Uses in Lubrication
2	Gone with the Air Elemental
3	Paradise Displaced
4	A Thousand Nights and a Night
5	201. A Sea Odyssey
6	Farewell To Limbs, A Pictoral Vorpel Glossary
7	Moby Dragon
8	Better Caves and Dungeons Cookbook
9	Snow Dwarf and the Seven Wights
10	Humantales for Young Fairies

4. Scroll Room

This vast room contains racks that are filled with thousands of scrolls.

The PCs may search the shelves for scrolls that interest them, though none may be removed from the library without Martek's permission. For every turn they search without Martek's aid, roll 1d10. On a roll of 10, a magical scroll has been found; on all other rolls, they find only non-magical scrolls. Use the tables below as a guide to the scrolls that are available.

Magical Scrolls Table

Roll	Title
1	<i>Scroll of Polymorph</i>
2	<i>Scroll of Seven Spells</i>
3	<i>Scroll of Protection From Undead</i>
4	<i>Scroll of Protection From Petrification</i>
5	<i>Scroll of Four Spells</i>
6	<i>Scroll of Five Spells</i>

Non-Magical Scrolls Table

Roll	Contents
1	List of birthdays
2	A poster: Visit Beautiful Cormyr
3	A shopping list
4	An award: Wizard of the Year
5	A painting of a dancing girl
6	A poster: Martek for Shah

5. Transdimensional Door

Strange writings are carved in all but two of the walls in this octagonal room. On the two walls without carvings, one is an arched exit and the other is very smooth and white.

The smooth white wall is an interdimensional teleport. It will not work until the first four words are spoken from the inscriptions on the walls to either side. These runes, which reform themselves to be easily read, say:

Turnin-minlink-giraf-jek, words of power here we speak.

When these words are spoken, the smooth wall will show a picture of whatever place the per-

son speaking the words is thinking of. Each time the four words are spoken, the wall will reset to a new place if the person activating the teleport is not thinking of anywhere in particular. If more than one person activates the door at the same time, and they have different destinations, the picture will switch back and forth between them.

If anyone steps into the picture on the wall, he will suddenly appear there. Note that this could have unpleasant effects, as if the person were thinking of the inside of a metal vase, for example.

The teleport is one-way only. Only if Martek gives permission may anything be removed from the Inner Sanctum through the teleport. If the PCs activate the teleport without releasing Martek, the Star Gems they have collected will remain here. Martek used this method to imprison Khalitharius long ago. If he has been brought back to life, Martek will activate the door for the PCs. You may wish to use the optional ending provided in the description for Vault of Martek (area 2).

On each of the other walls are written the following phrases, the first two to the left of the entry door, and the second two to the right. They are clues to the party on what to do here, in case they are not able to figure it out. The

runes reform to the language preferred by the reader.

You are not lost with the gems of stars.
Bid his return from very far.

Replace the gems that once were hid
And light shall form life's pyramid.

6. Treasury

The doors open into a magnificent treasure room filled with wondrous things. The back wall, 50 feet away, is draped with fine cloth emblazoned with a heraldic crest. The room is 40 feet wide and the ceiling is 60 feet above. Treasures and coins spill from fine wooden chests and delicate pottery.

The following treasure items are neatly arrayed in this room: 9300 cp; 6400 ep; 17,100 sp; 12,400 gp; 2250 pp; and 20 100-gp gems. Of magical treasure, there may be found the following: *wand of fireballs*; *potion of clairaudience*; *sword of 9 lives stealing* +2; *crystal ball*; *shield* +5; *scale mail* +1; *morning star* +1; *sword of dancing*; *ring of protection* +3.

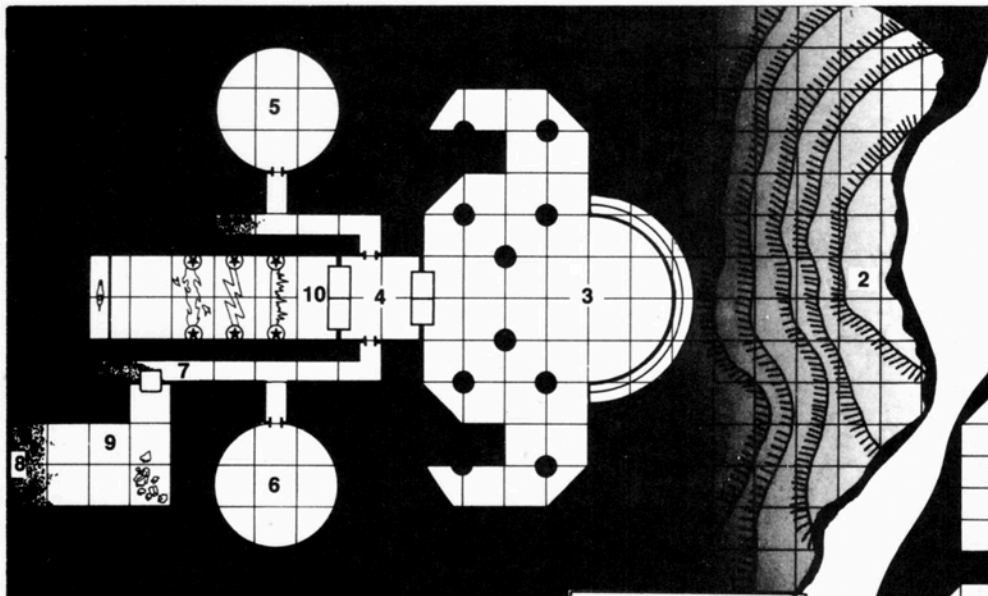

SUNKEN CITY OF PAZAR

MAP 7-1

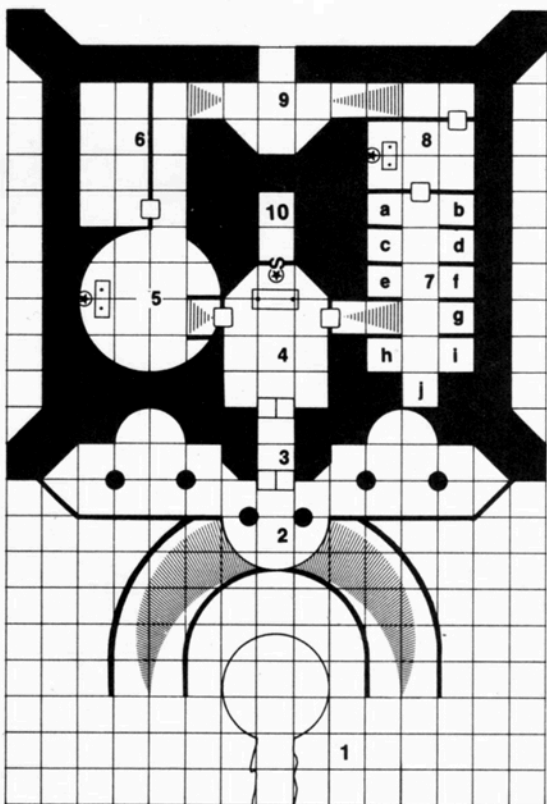

MAP 8-1 TEMPLE OF AMUN-RE

KEY

- DOOR
- CONCEALED DOOR
- SECRET DOOR
- ARCHWAY
- WATER
- ALTAR
- STATUE
- SARCOPHAGUS STANDING
- SARCOPHAGUS OPEN
- SARCOPHAGUS
- STAIRS
- THRONE
- MISTS

1 SQUARE = 10 FEET

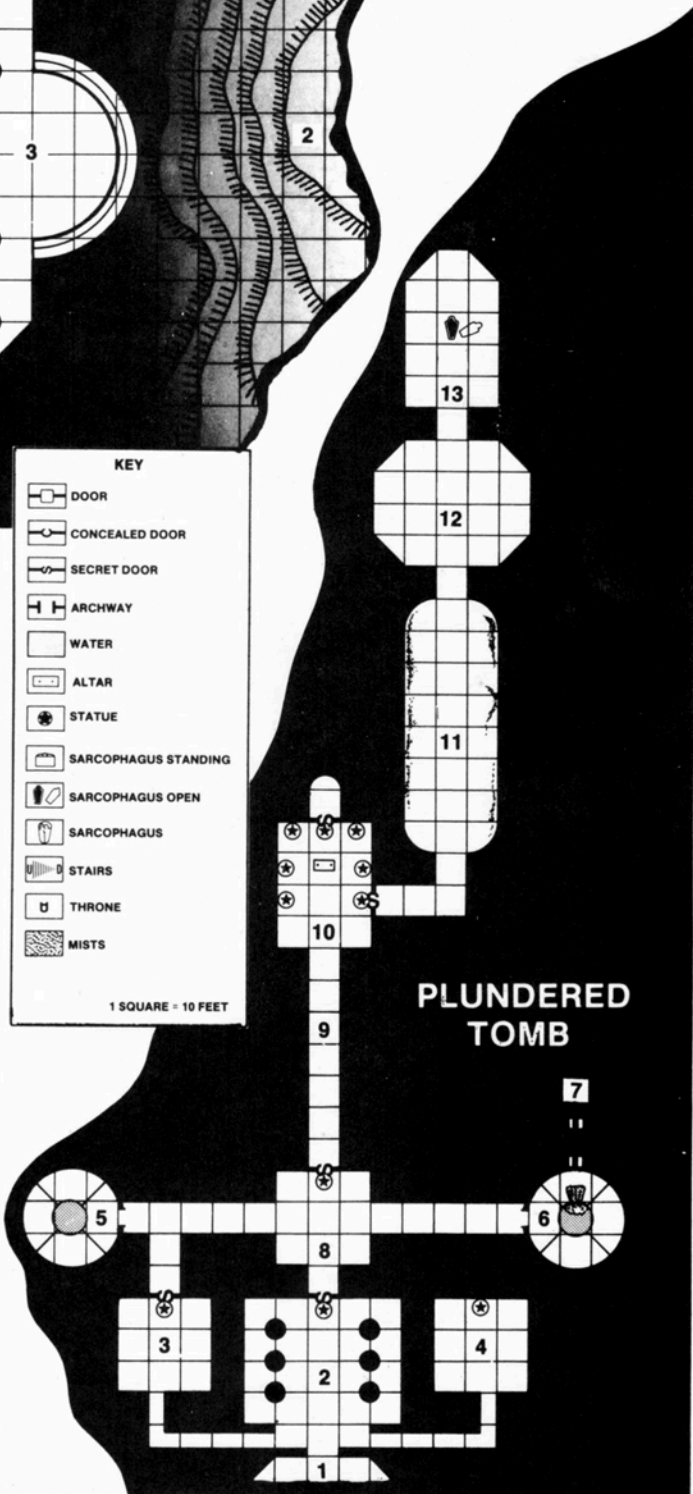

PLUNDERED TOMB

MAP 8-3
KORDAN'S
MASTER MAZE

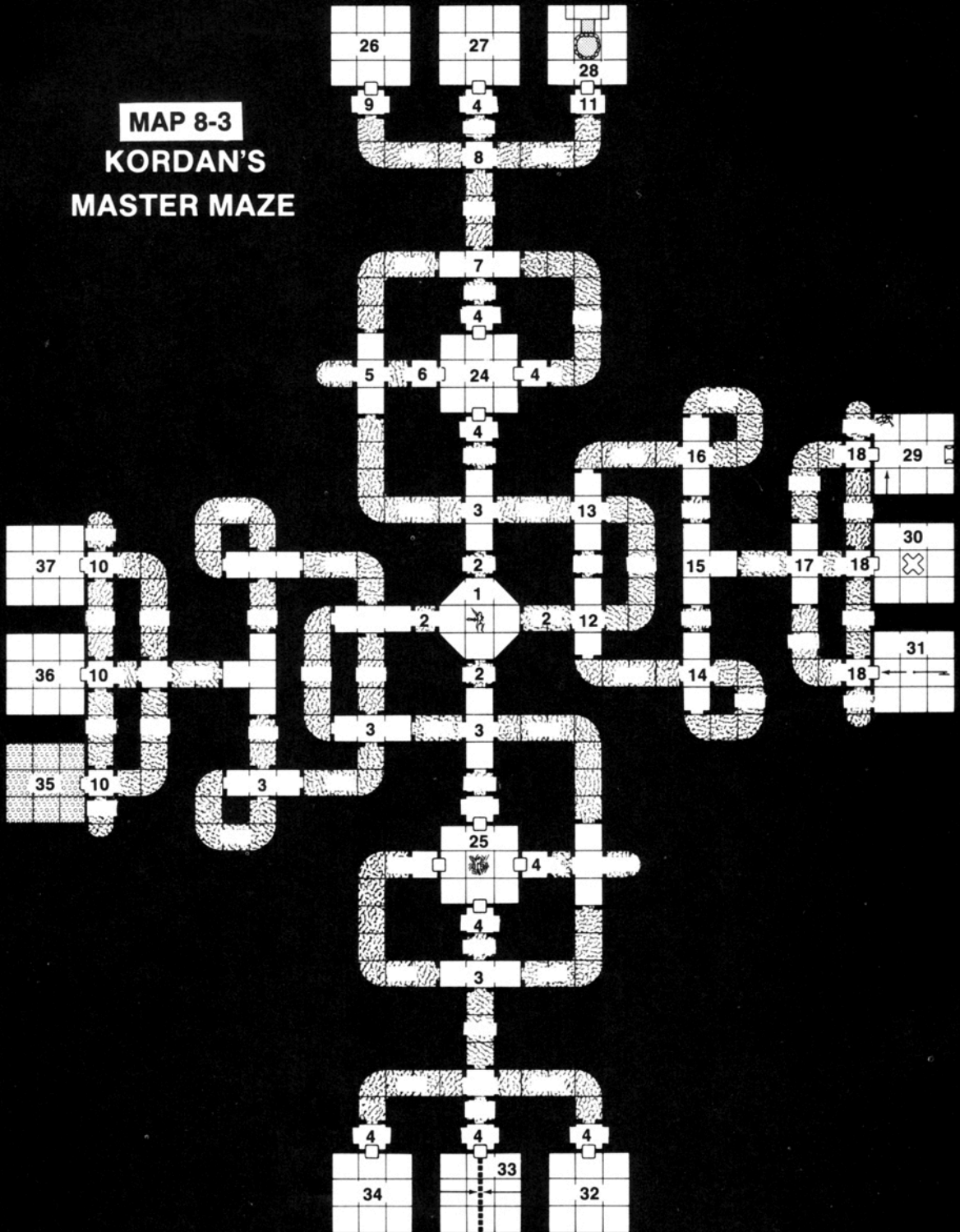

MAP 8-4

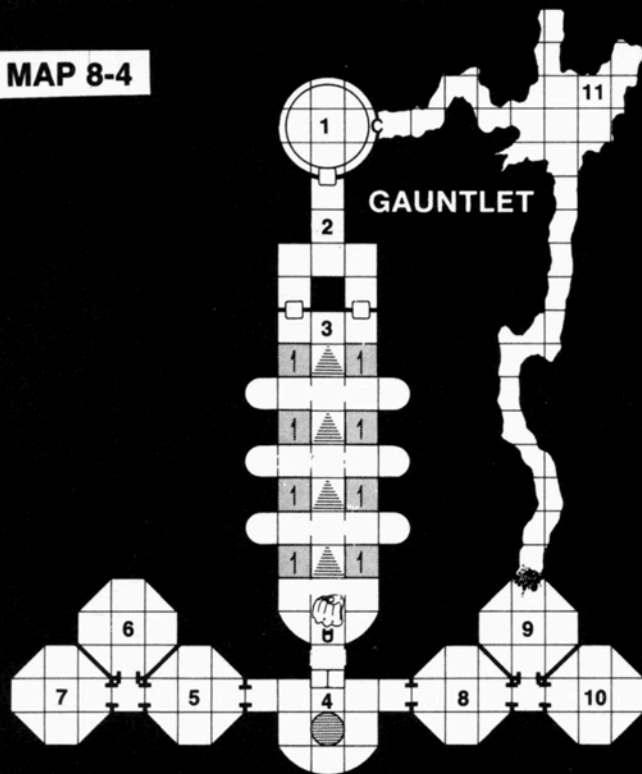

MAP 8-6

TOMB OF AMUN-RE

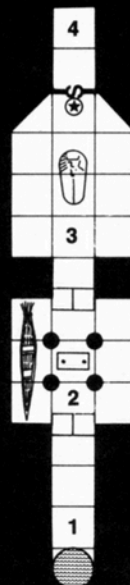

	DOOR		SARCOPHAGUS STANDING
	CONCEALED DOOR		SARCOPHAGUS OPEN
	SECRET DOOR		SARCOPHAGUS
	ARCHWAY		STAIRS
	WATER		THRONE
	ALTAR		MISTS
	STATUE		TRAP DOOR

1 SQUARE = 10 FEET

MAP 8-5

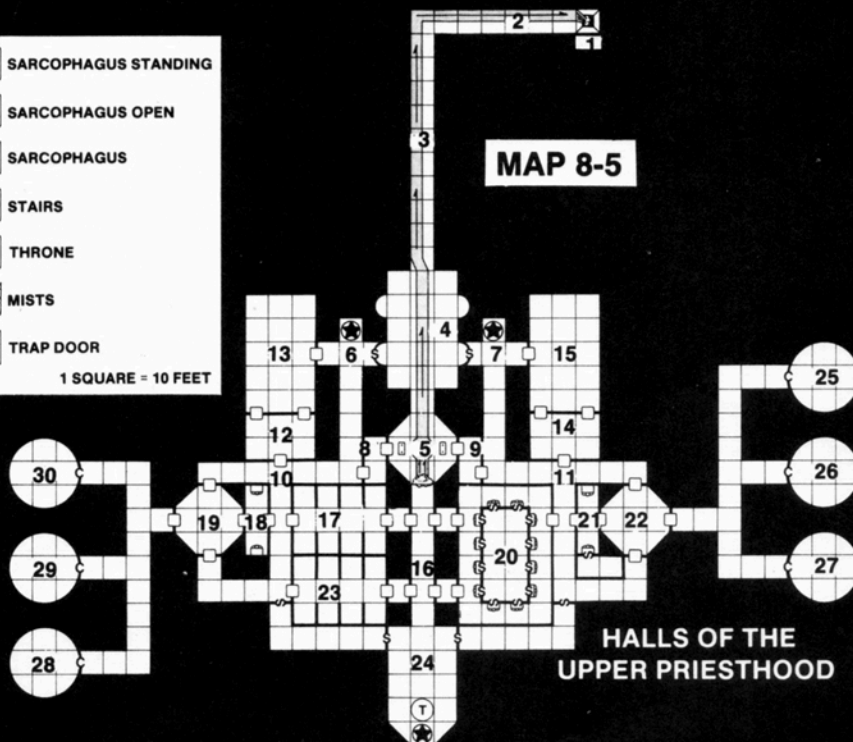





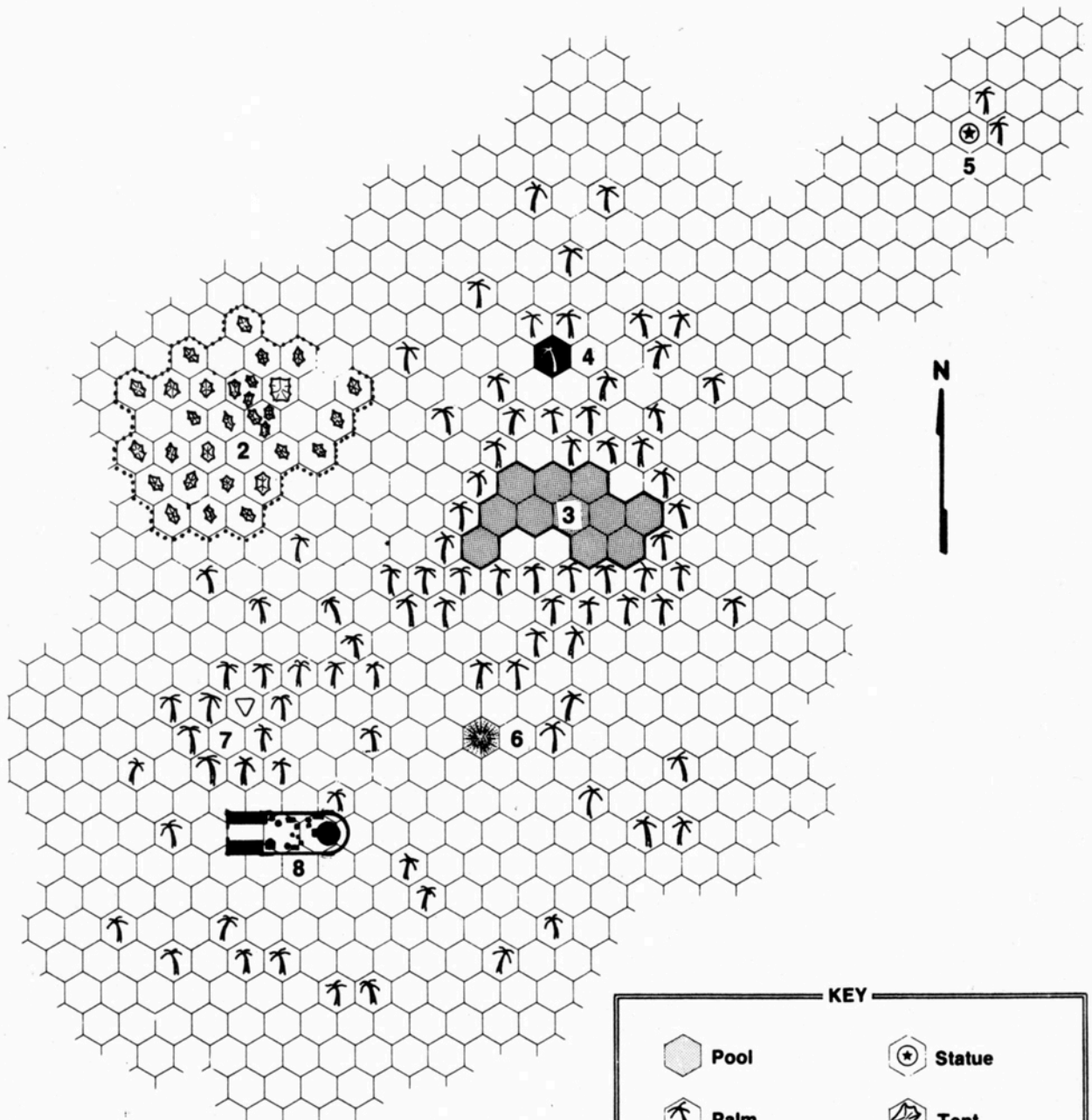

HALLS OF THE UPPER PRIESTHOOD

MAP 9-1 Oasis Area



KEY

 Pool	 Statue
 Palm	 Tent
 White Palm	 Burned Camp
 Monolith	1 HEX - 100 FEET

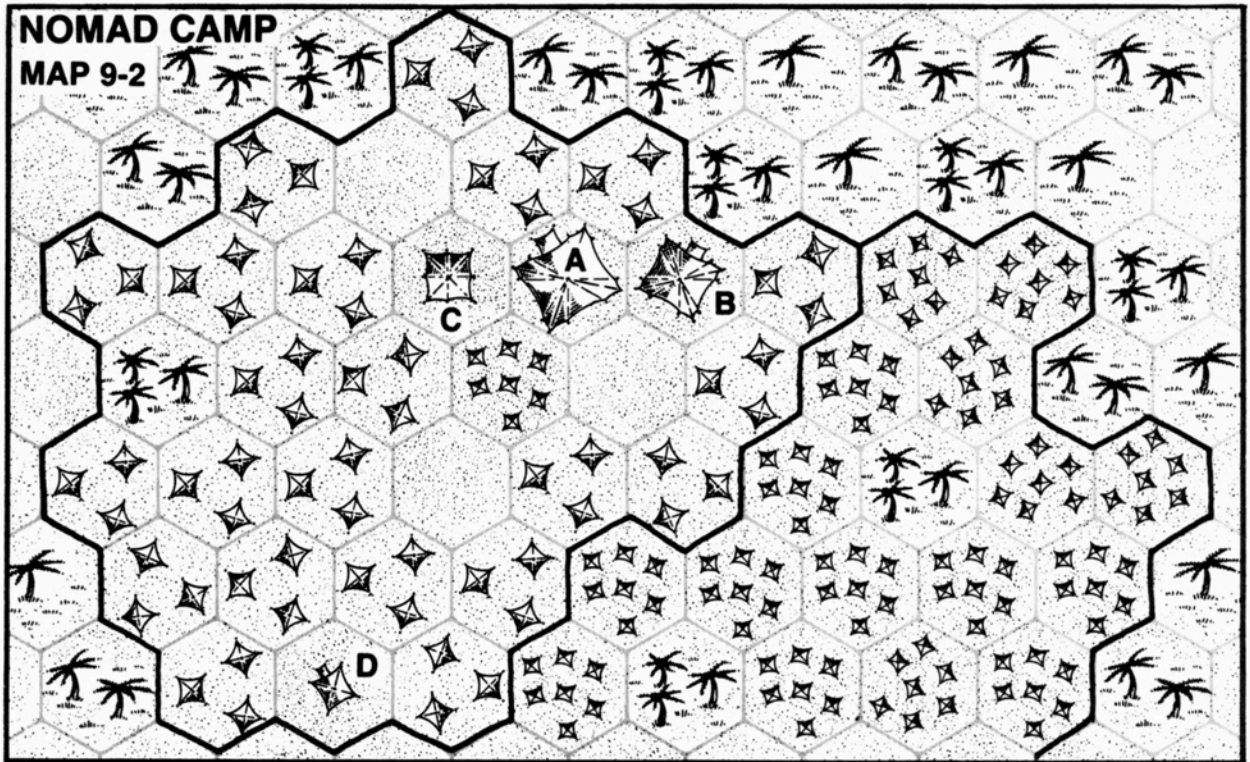

MAP 9-3

1 SQUARE = 10 FEET

SANDVOYAGERS COMPOUND

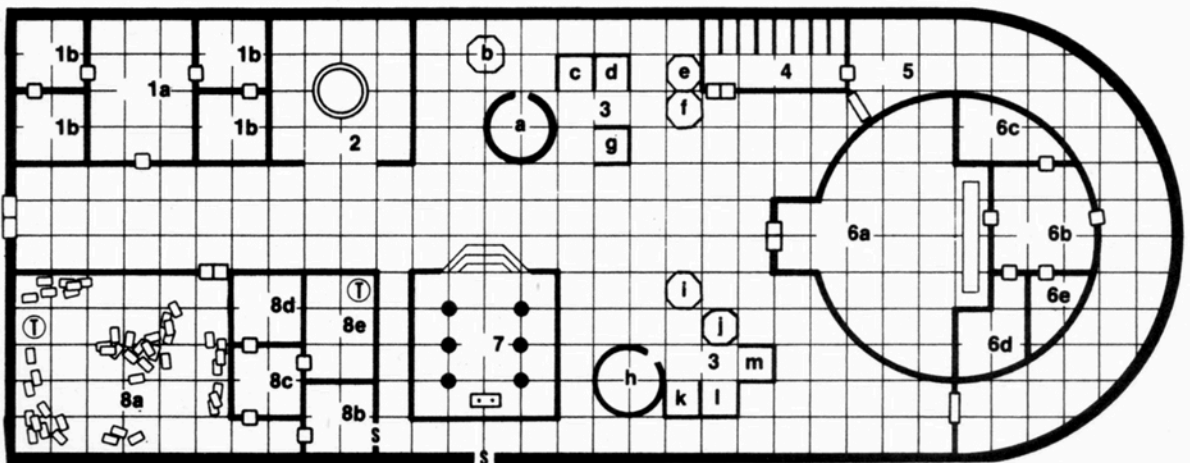
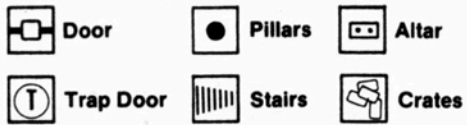

MAP 10-1

TEMPLE OF SET

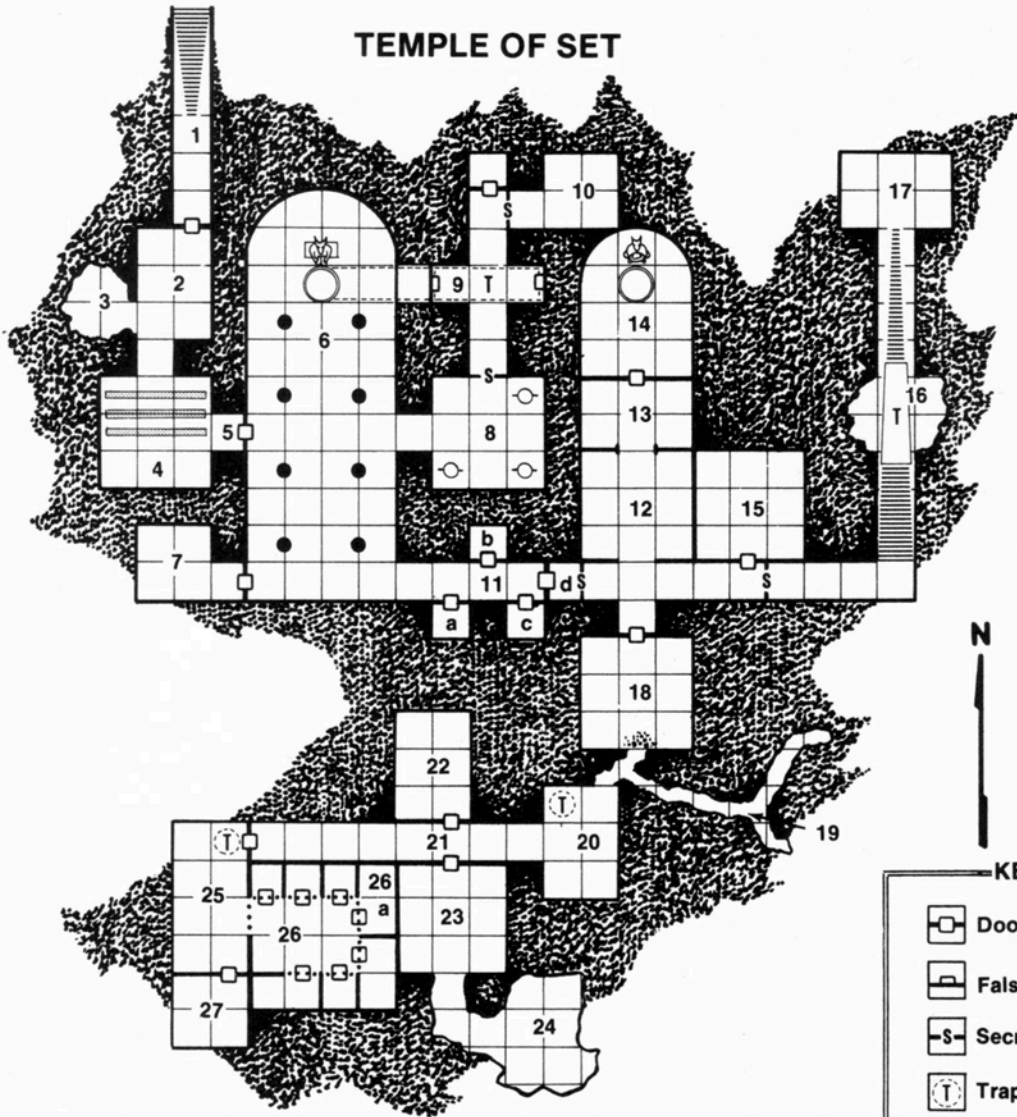

1 SQUARE = 10 FEET



KEY

	Door
	False Door
	Secret Door
	Trap Door
	Cell Bars
	Stairs
	Pillar
	Rubble
	Basin
	Well
	Trap
	Arch

MAP 11-1

ENTRANCE TO THE CRYPT OF BADR AL-MOSAK

SIDE VIEW



MAP 11-2
CRYPT OF BADR AL-MOSAK

PIT DROPS
100 FEET TO WATER

OVERHEAD SHAFT ENTRANCE

LOWER LEVEL

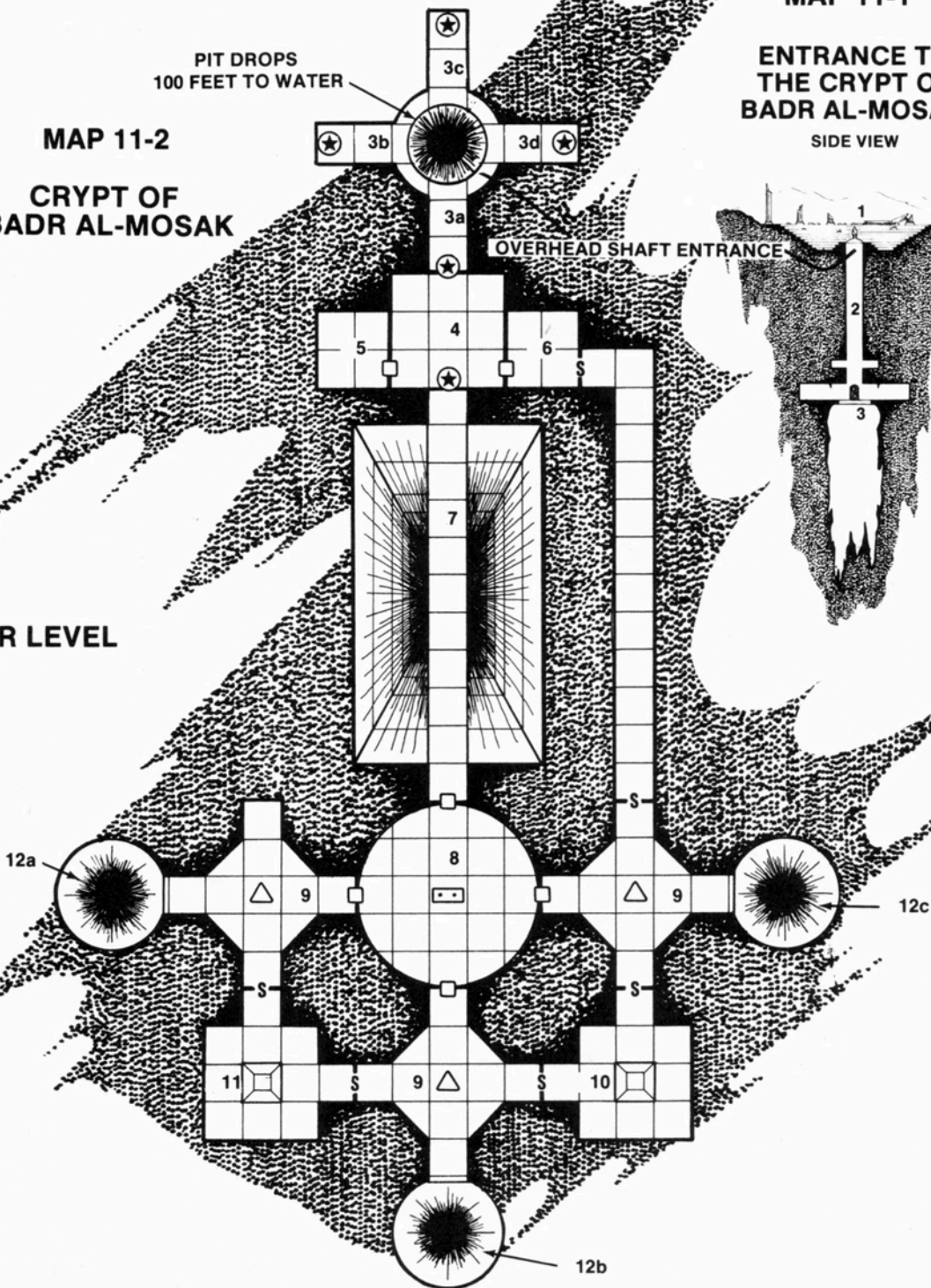

1 HEX = 5 FEET

UPPER LEVEL

GRID LINES INDICATE
10' x 10' SQUARE

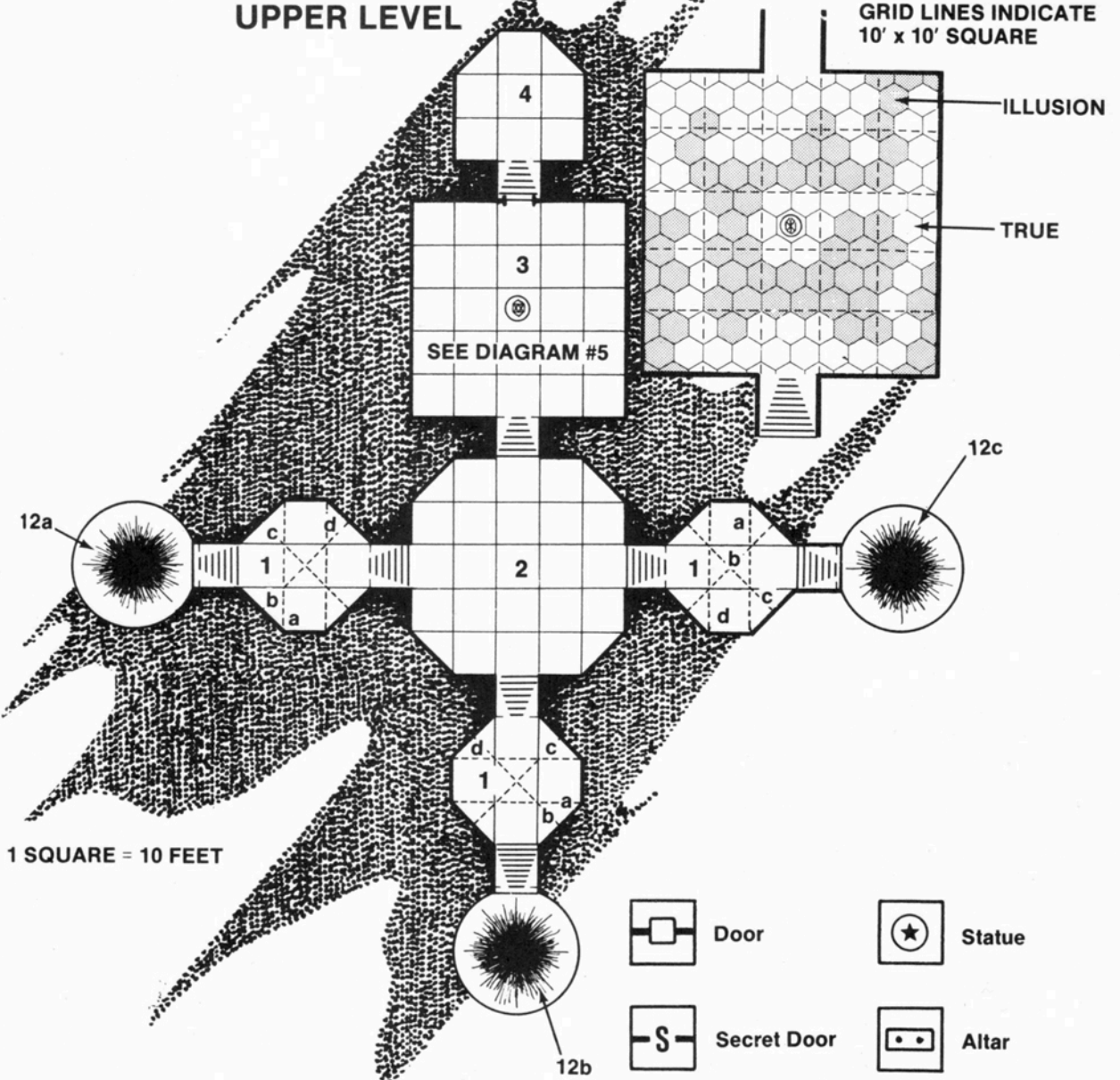

Door



Statue



Secret Door



Altar



Stairs



Light Beam



Obelisk



Open Cube

Lost City of Phoenix Map 12-1

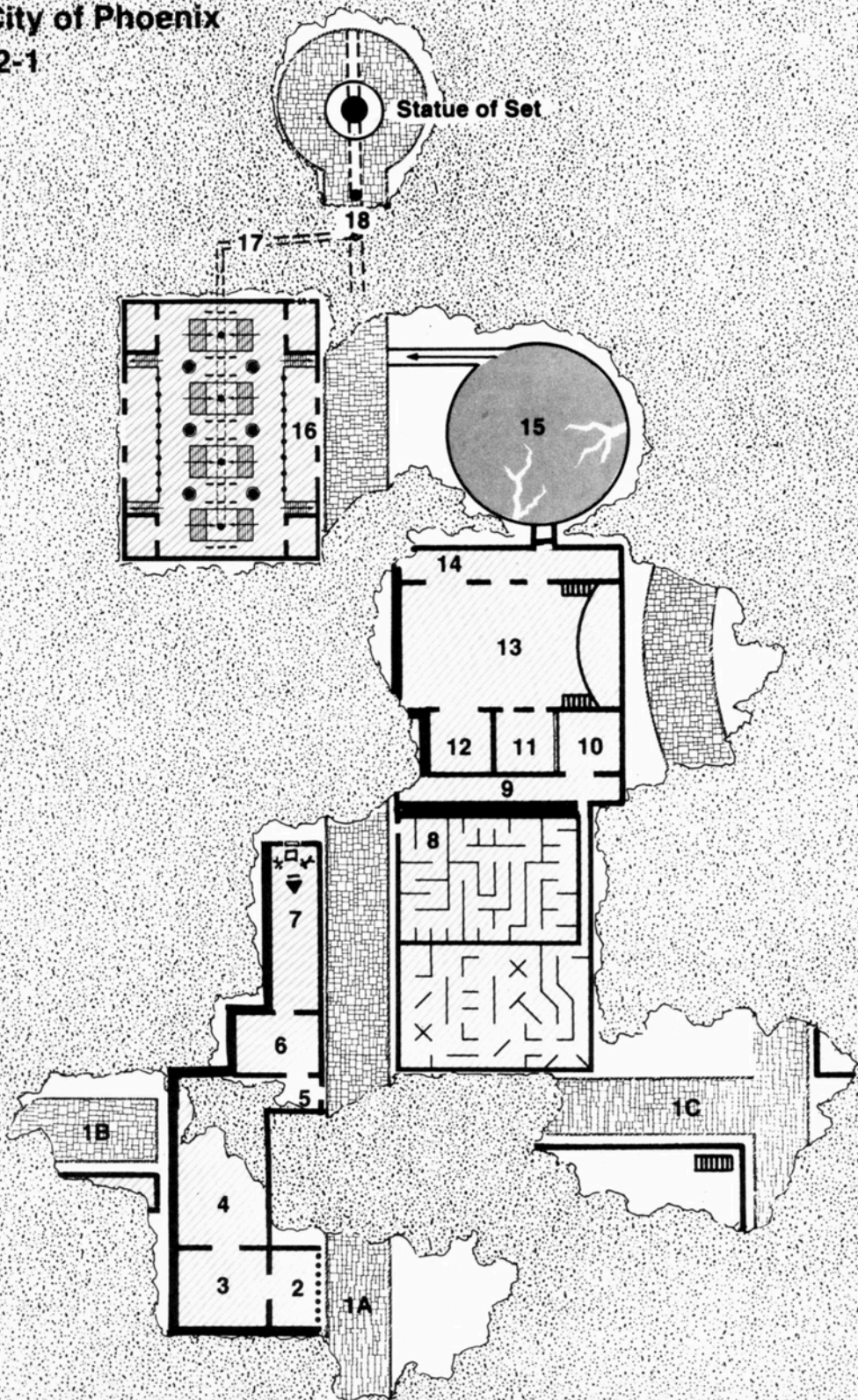



MAP 13-1 Overview

The large overview hex equals one mile 5280 ft.

MAP 13-2 City Detail

Each large city detail hex equals 1/10 of a mile 528 ft.

Each small hex equals roughly 52 feet.

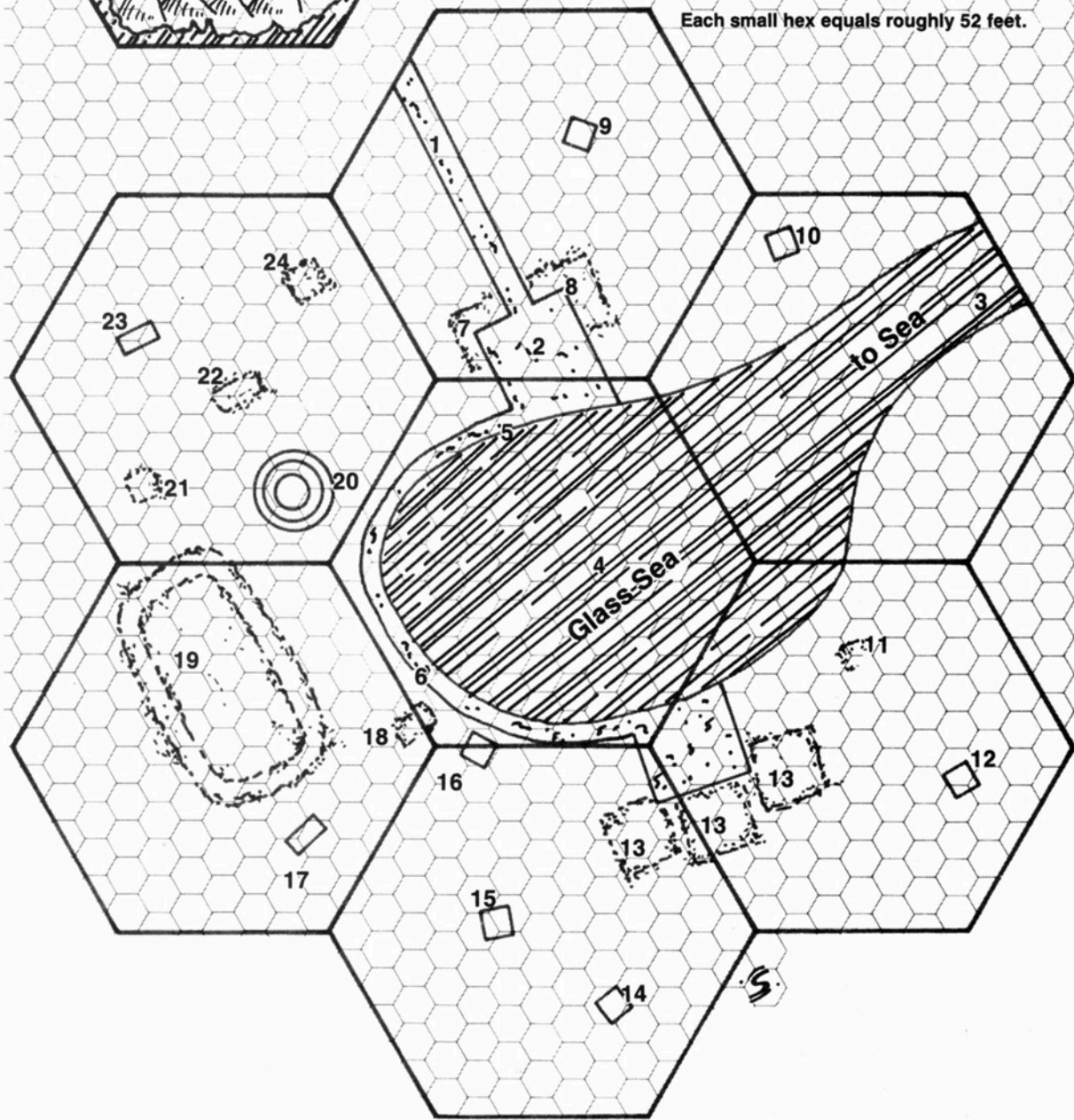

Area 23
Baths of Drusus
Detail of Map 13-2

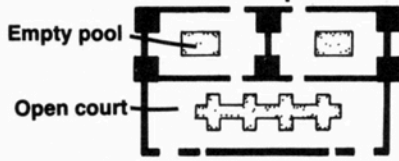

Area 17
Temple of Ra
Detail of Map 13-2

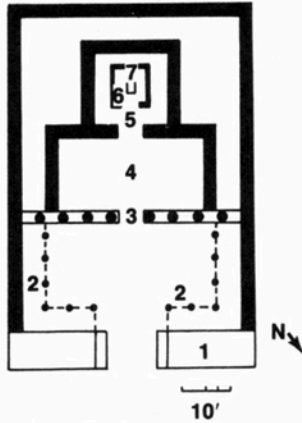

Map 13-3

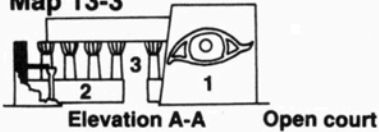

Area 12
Baths of Kordek
Detail of Map 13-2

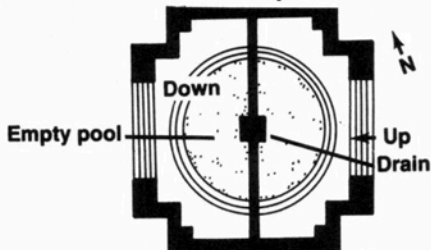

Area 15
Baths of Persepolis
Detail of Map 13-2

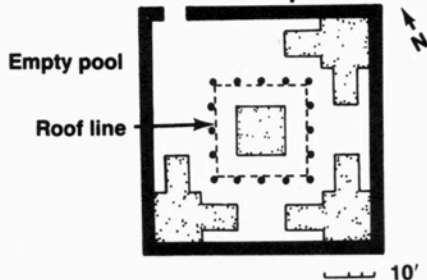

Area 9
Temple of Horus
Detail of Map 13-2

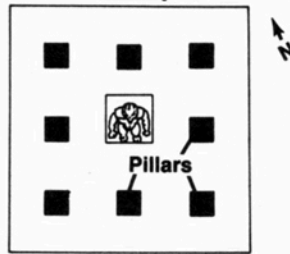

Area 10
Temple of Prometheus
Detail of Map 13-2

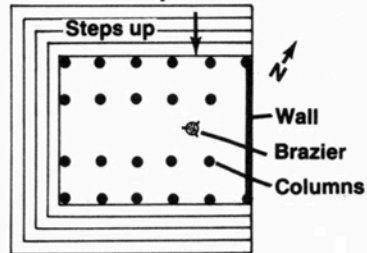

Area 14
Palaestra
Detail of Map 13-2

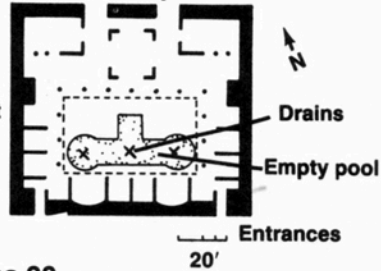

Area 20
Temple of Balder
Detail of Map 13-2

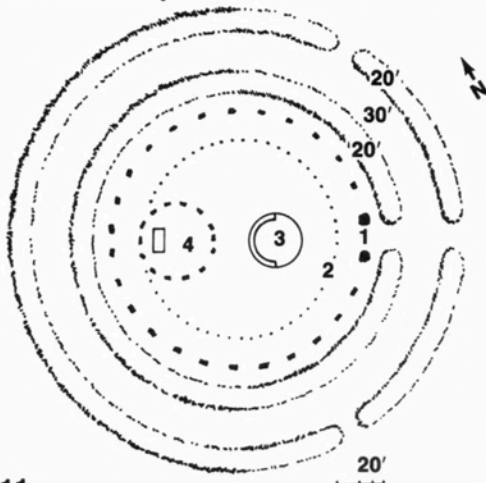

Garden
1 hex = 200 feet

MAP 14-2
GARDEN OF THE CURSED

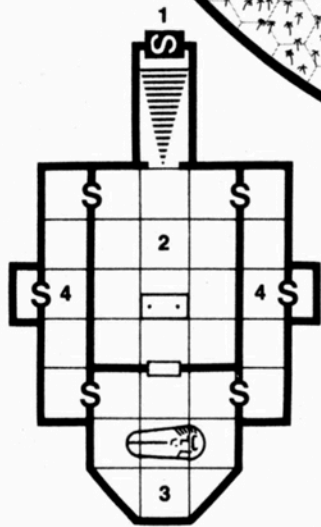
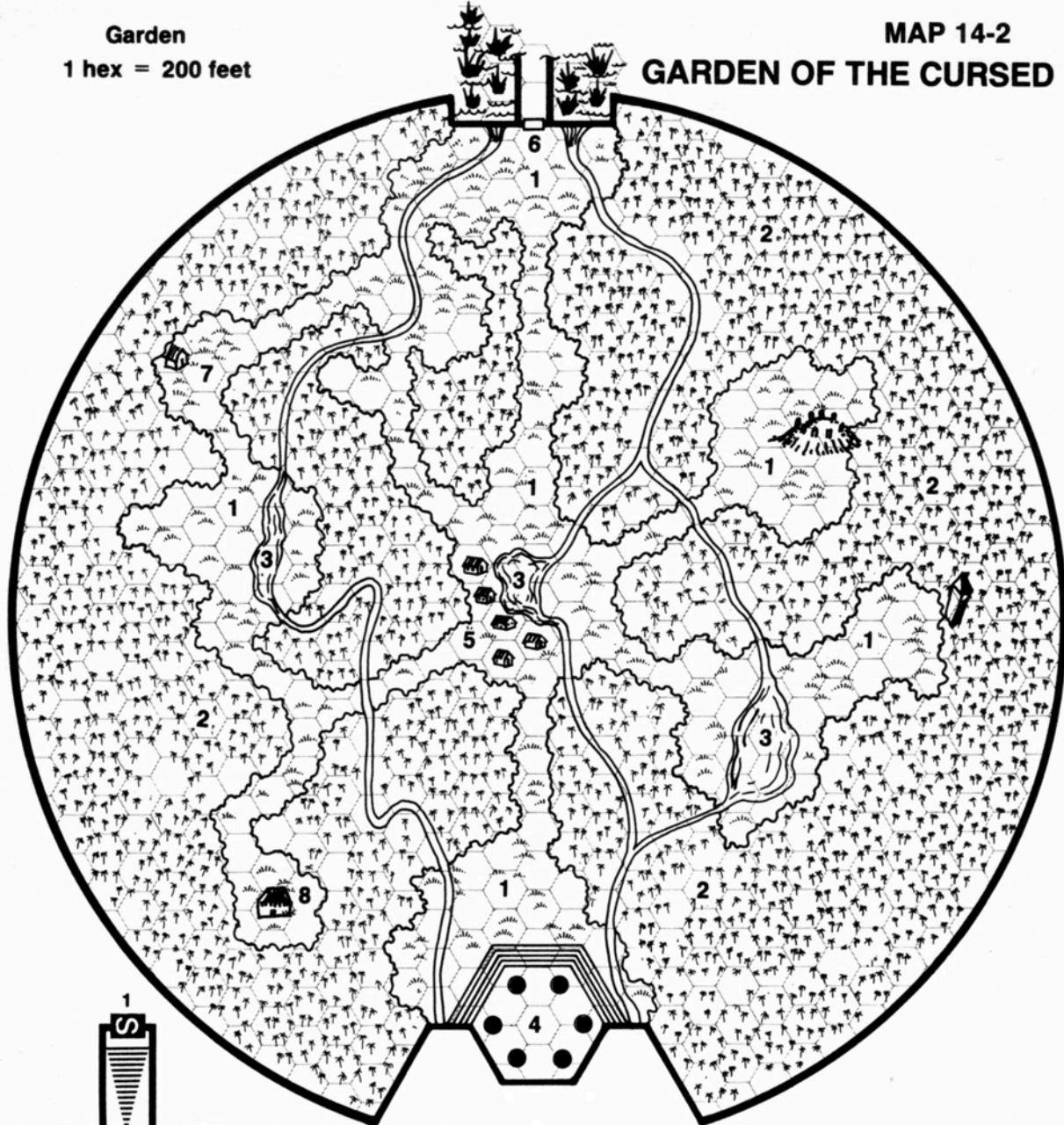

MAP 14-1
PILLAR OF MARTEK
1 square = 10 feet

Crystal Prism MAP 14-3
 1 square = 10 feet

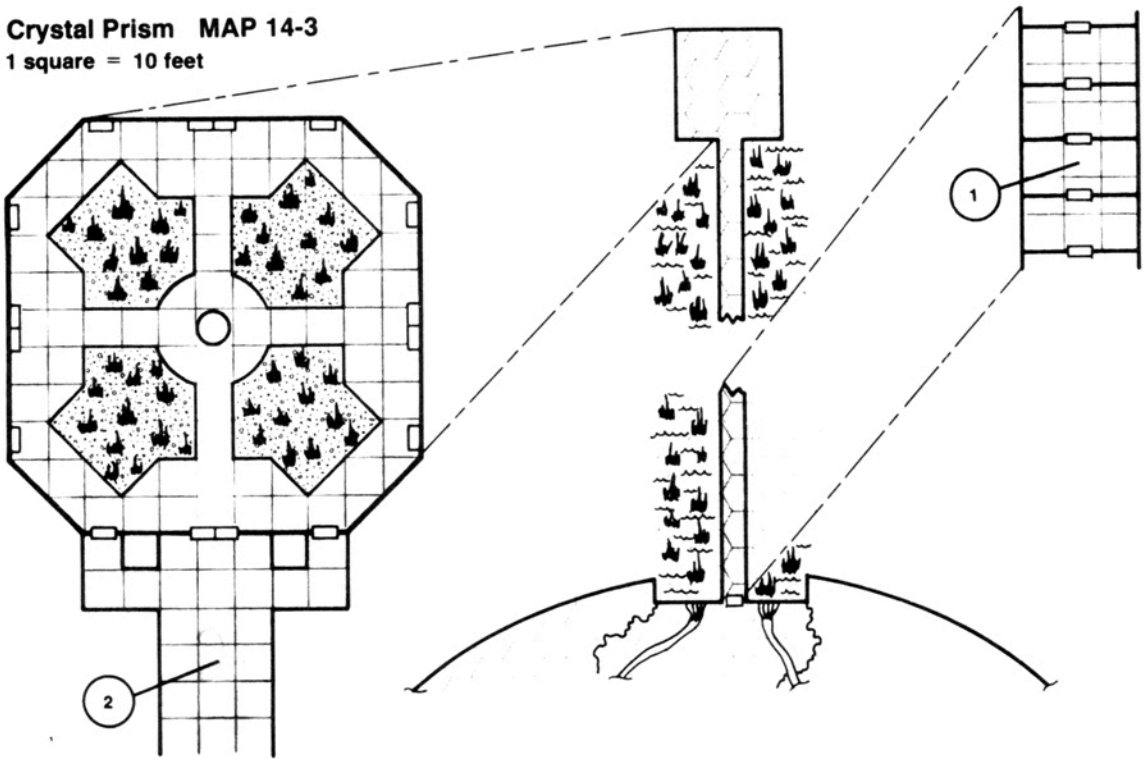

MAP 14-4

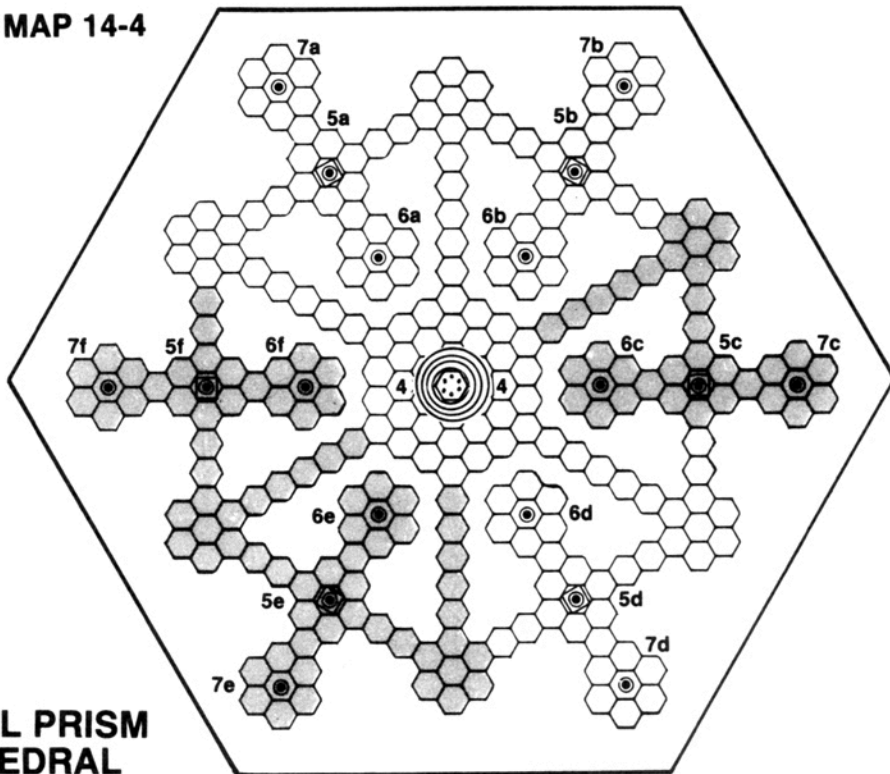

**CRYSTAL PRISM
 CATHEDRAL**

Black Abyss MAP 14-5

1 hex = 120 feet before area 3
(see text for details)

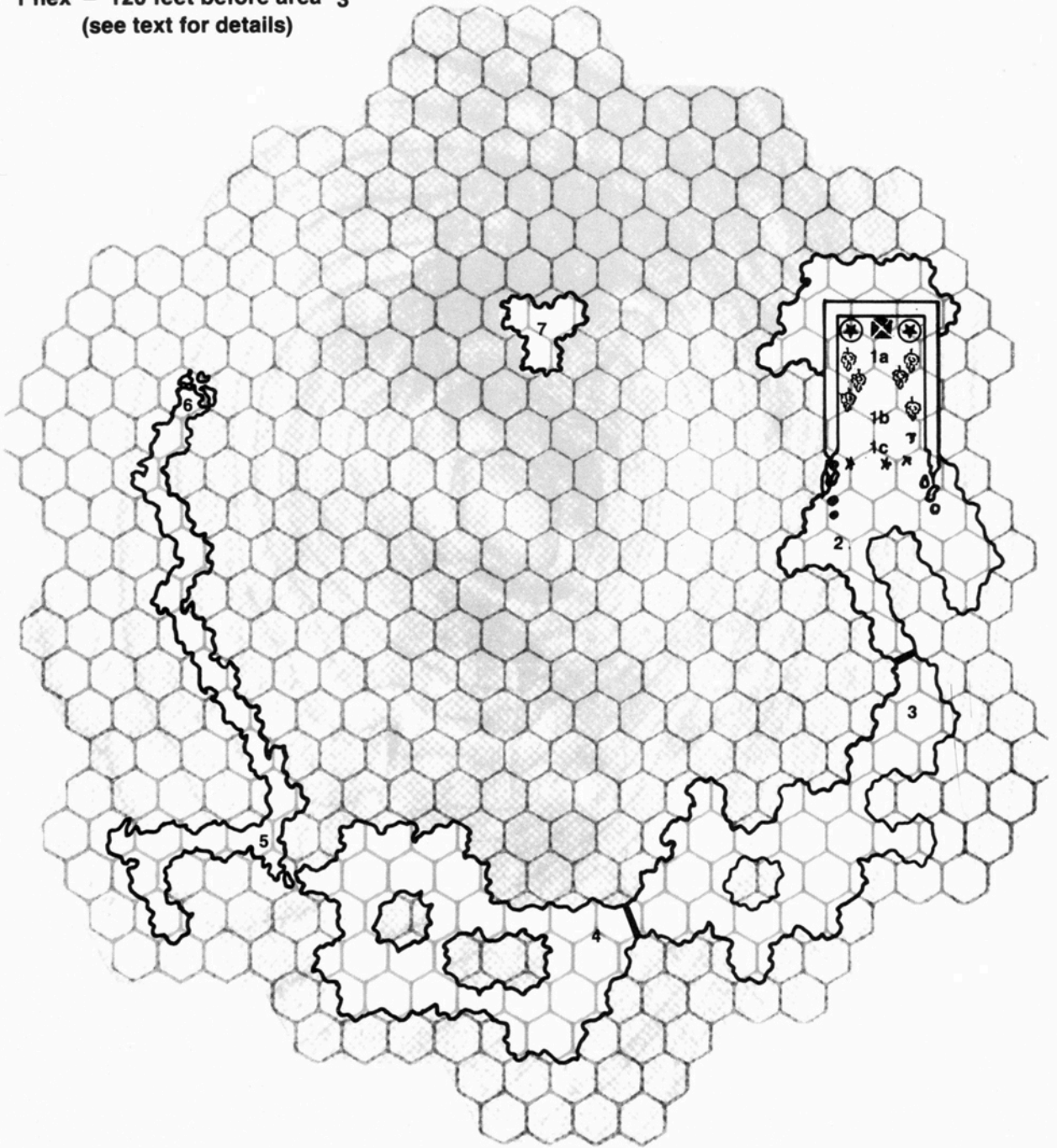

MAP 14-6 MOBIUS TOWER

1 square = 10 feet

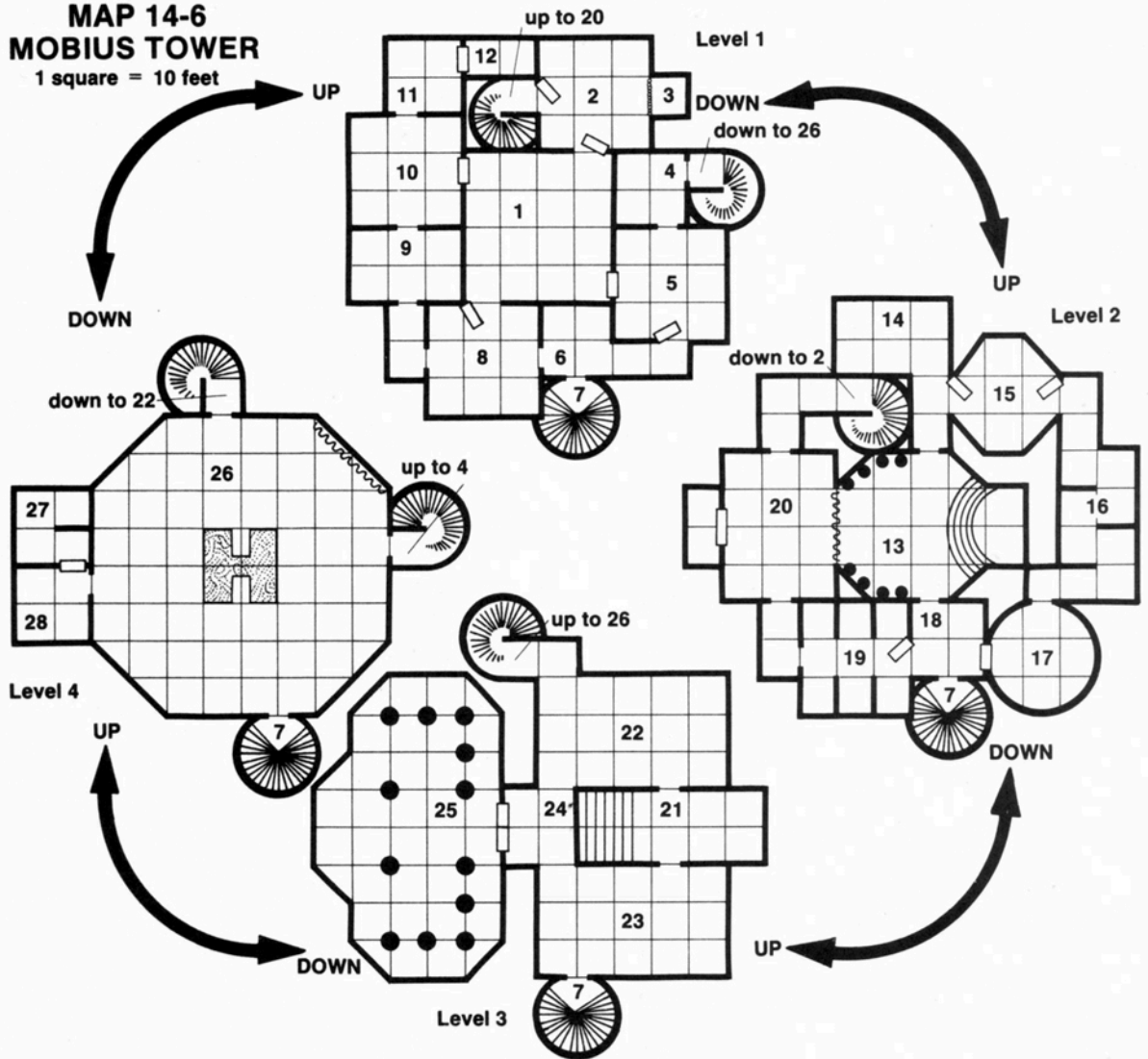

	Door		Column
	Secret Door		Curtain
	Stairs		False Door
	Altar		Statue



MAP 14-7
AL-ALISK DESERT
 1 hex = 2 miles

	Hills
	Lancers of Death (3)
	Death Watch (4)
	Edge of the World (2)

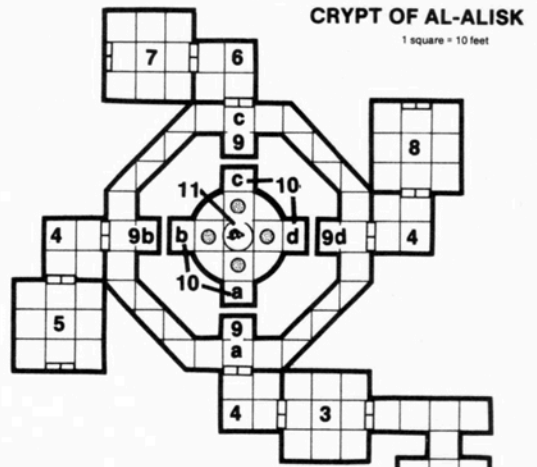

MAP 14-8

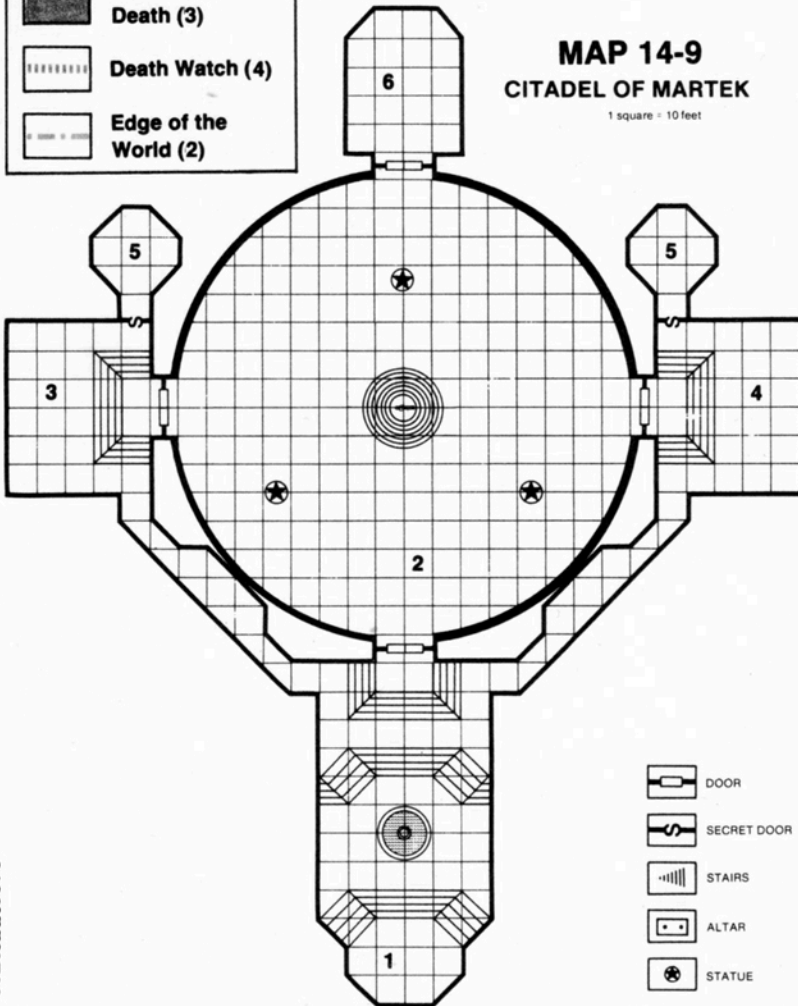

MAP 14-9
CITADEL OF MARTEK
 1 square = 10 feet

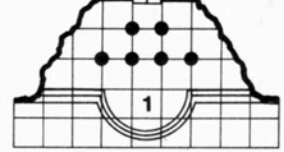

	DOOR
	SECRET DOOR
	STAIRS
	ALTAR
	STATUE

9199XXX0702

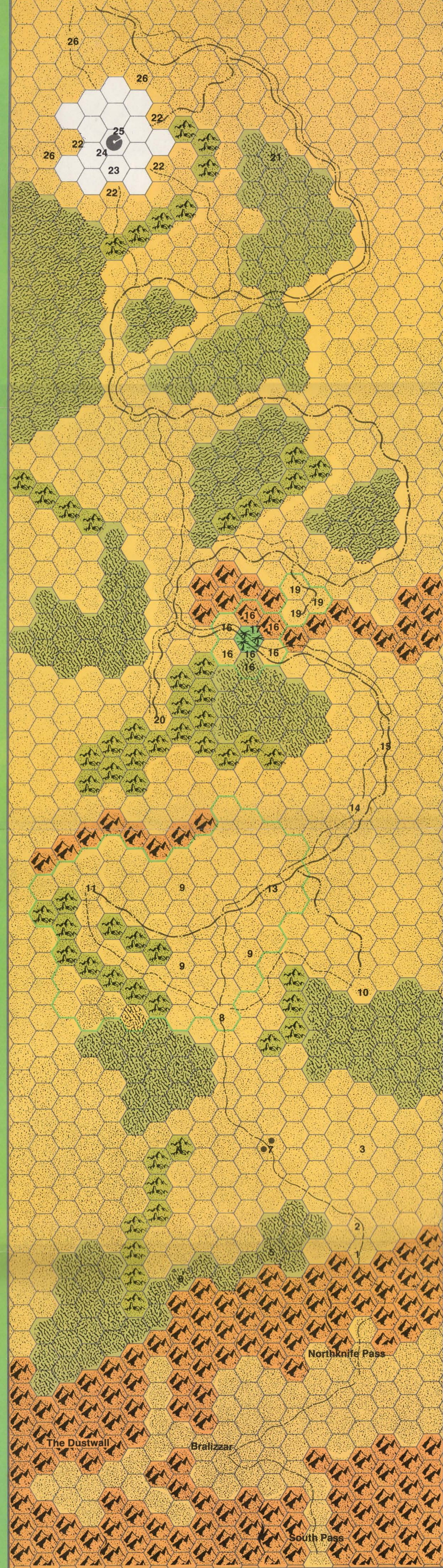

- | | | | |
|---------------------|-----------------|----------------------------------|-----------------------------|
| Sand | Valley of Athis | 1. Sandvoyagers Trail | 14. Bleached bones |
| Mountains | Other trails | 2. Sandvoyagers Guideposts | 15. Oasis of Akhir |
| Blasted hills | Other valleys | 3. Desert dunes | 16. Airlancer Patrol Zone |
| Shifting sands | Mountain pass | 4. Blasted hills | 17. Oasis of the White Palm |
| Oasis | Sinkholes | 5. Shifting sands | 18. Path of the Malatath |
| Sandvoyagers' Trail | Border | 6. Sinkholes | 19. Lands of Carthag |
| | | 7. Gates of Sule | 20. Crypt of Badr Al-Mosak |
| | | 8. Signposts | 21. Oracle Stone of Martek |
| | | 9. Lands of Bakar | 22. Grounded Cloudskates |
| | | 10. Pazar | 23. Skysea |
| | | 11. Terbakar and Tomb of Amun-Re | 24. Cursed Island |
| | | 12. The Hinjaz | 25. Cursed City of Stone |
| | | 13. Battle plain | 26. Pillars of Martek |

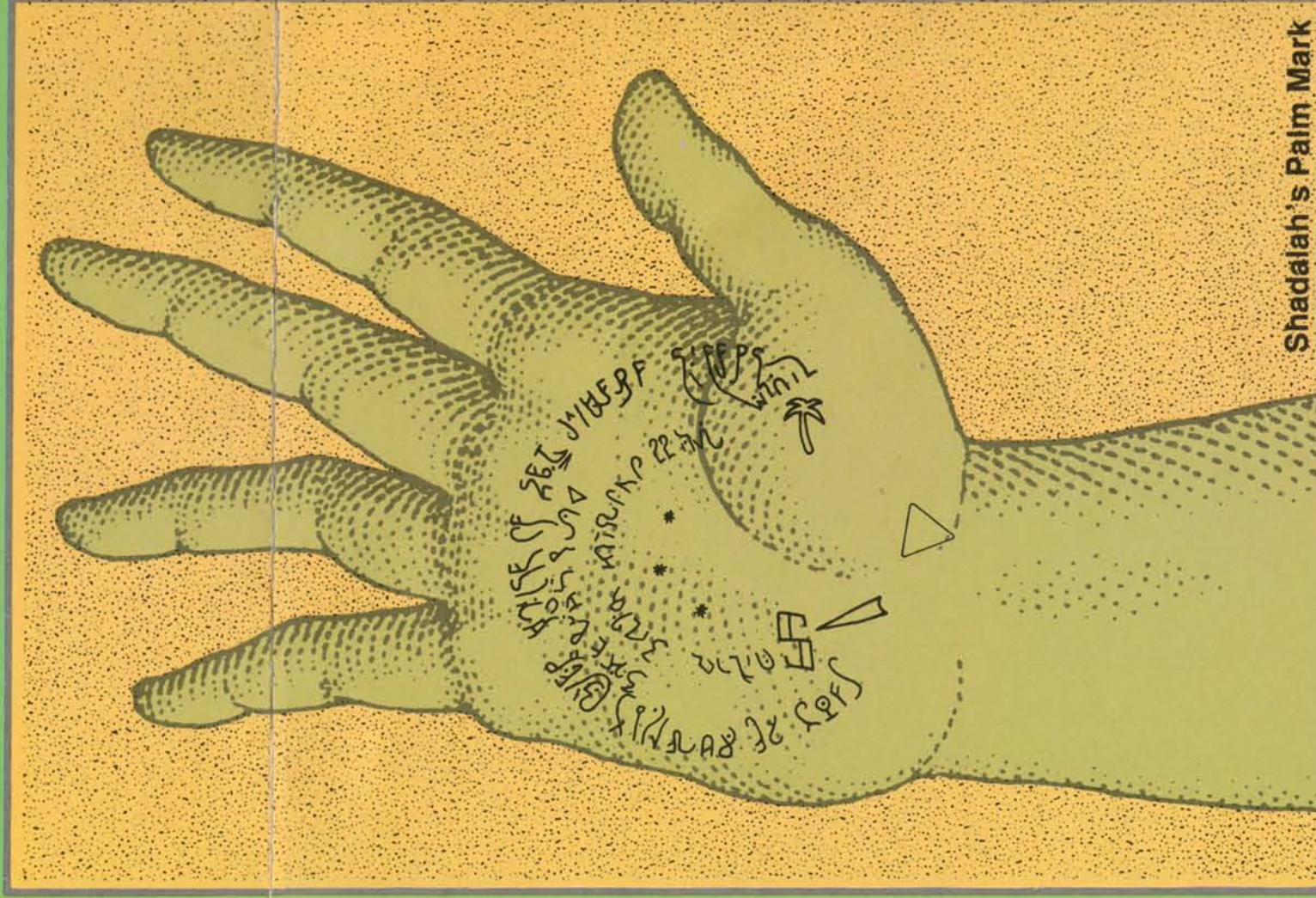

Shadalah's Palm Mark

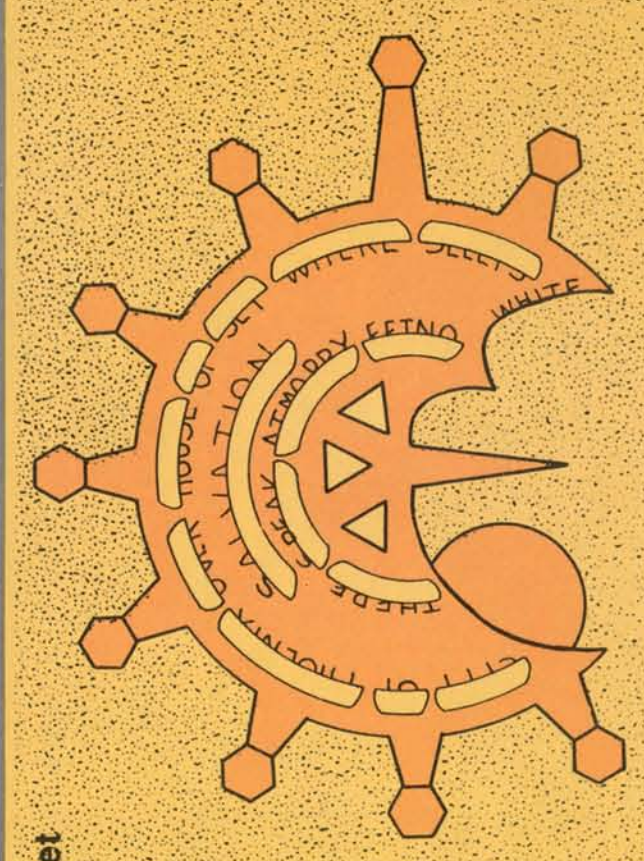

Amulet



Map 6-2 (Players)

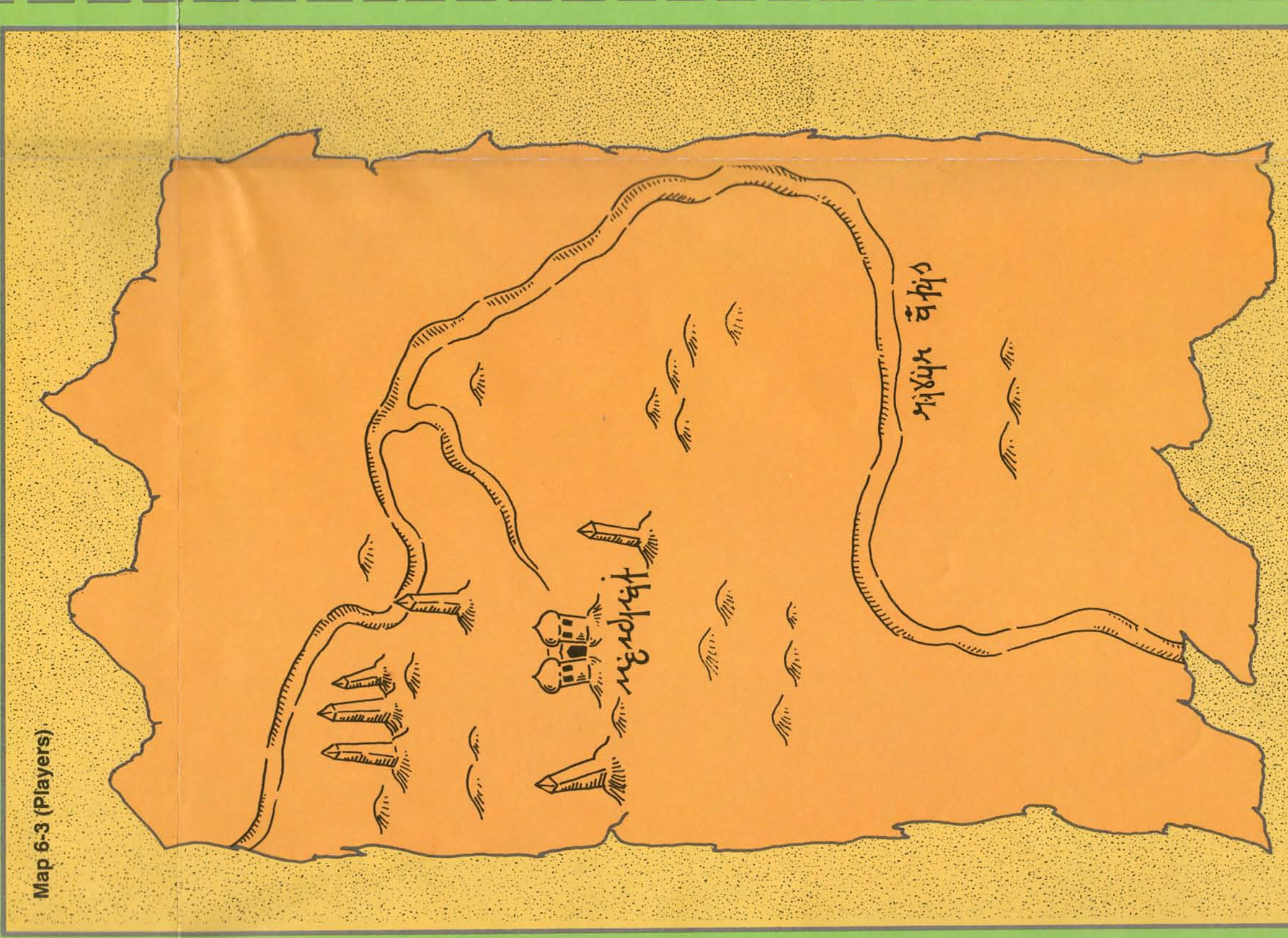

Map 6-3 (Players)

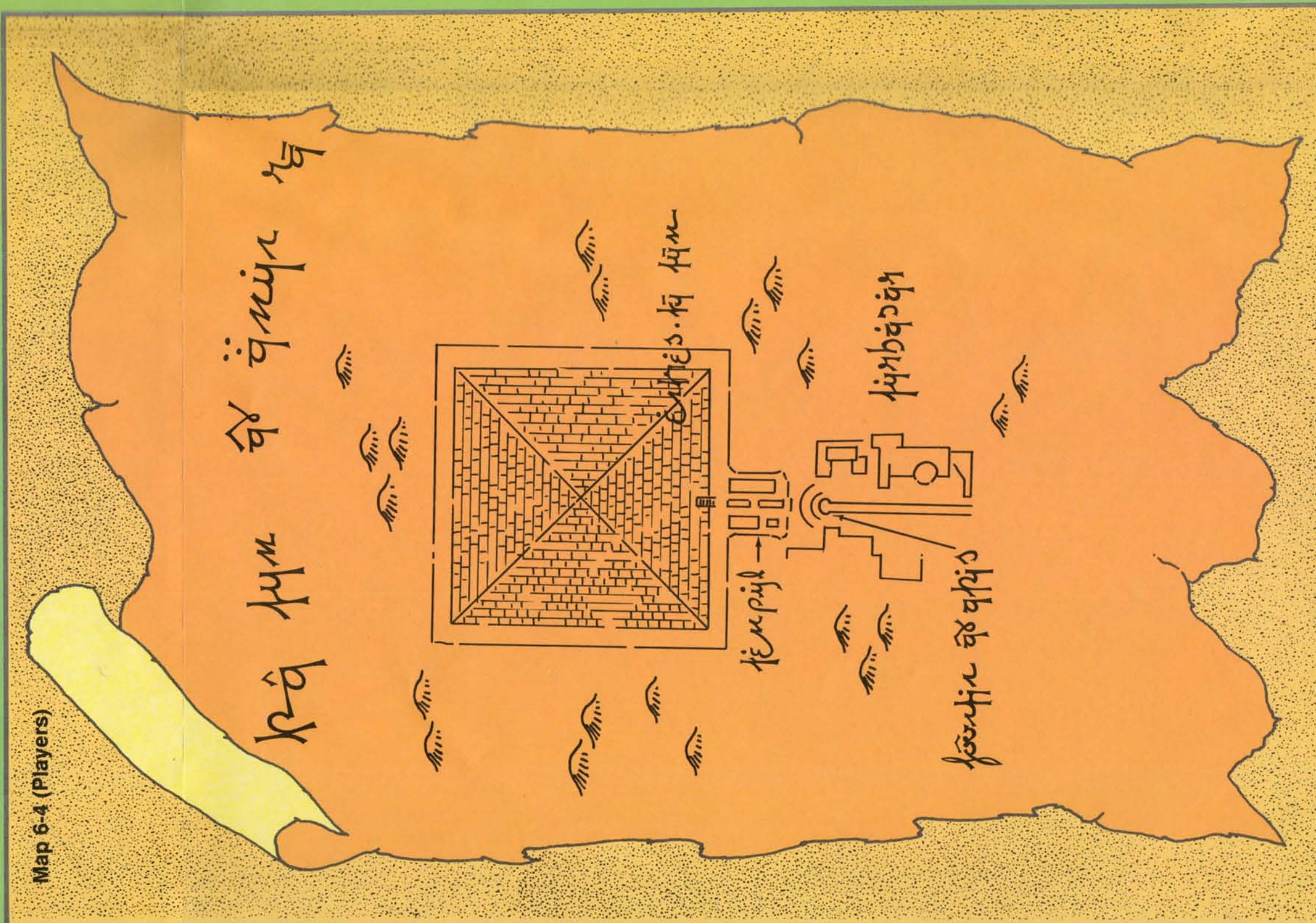

Map 6-4 (Players)

ā	ā	gate	p	p	pet
ā	ā	cat	p	q	quit
ā	ā, ō, ū	father, from, of, under, the	x	r	ride, write
b	b	bat	s	s	cease
d	d	dog	t	t	top
ē	ē	be, street, meat	ū	ū	unicorn, cute, base, through
ē	ē	set	ū	ō, o	put, book, could, cure, river
f	f	far, off, enough, pharaoh	y	v	vent
g	g (hard sound)	goat	w	w	wall, where
h	h, wh	host, who	l	y	year
ī	ī	lime, sky	z	z	zebra
ī	ī	hid			
j	j, g (soft sound)	jump, germ	st	st	state
k	k, c	keep, cut	ch	ch	churn
l	l	light	sh	sh	shop
m	m	mouse	th	th	the, think
n	n	note, know	ng	ng	bang
ō	ō	open, dough, know, for			
ō	ō	ought, taught, off, all, dog			
ō	ou, ow	out, howl			

- ua. It is the same as the one in the first part of the book.
- ub. The same as the one in the second part of the book.
- uc. The same as the one in the third part of the book.
- ud. The same as the one in the fourth part of the book.
- ue. The same as the one in the fifth part of the book.

- uf. The same as the one in the sixth part of the book.
- ug. The same as the one in the seventh part of the book.
- uh. The same as the one in the eighth part of the book.
- ui. The same as the one in the ninth part of the book.
- uj. The same as the one in the tenth part of the book.

- uk. The same as the one in the eleventh part of the book.
- ul. The same as the one in the twelfth part of the book.
- um. The same as the one in the thirteenth part of the book.
- un. The same as the one in the fourteenth part of the book.
- uo. The same as the one in the fifteenth part of the book.

- up. The same as the one in the sixteenth part of the book.
- uq. The same as the one in the seventeenth part of the book.
- ur. The same as the one in the eighteenth part of the book.
- us. The same as the one in the nineteenth part of the book.
- ut. The same as the one in the twentieth part of the book.

- uu. The same as the one in the twenty-first part of the book.
- uv. The same as the one in the twenty-second part of the book.
- uw. The same as the one in the twenty-third part of the book.
- ux. The same as the one in the twenty-fourth part of the book.
- uy. The same as the one in the twenty-fifth part of the book.

- uz. The same as the one in the twenty-sixth part of the book.
- va. The same as the one in the twenty-seventh part of the book.
- vb. The same as the one in the twenty-eighth part of the book.
- vc. The same as the one in the twenty-ninth part of the book.
- vd. The same as the one in the thirtieth part of the book.

- ve. The same as the one in the thirty-first part of the book.
- vf. The same as the one in the thirty-second part of the book.
- vg. The same as the one in the thirty-third part of the book.
- vh. The same as the one in the thirty-fourth part of the book.
- vi. The same as the one in the thirty-fifth part of the book.

Handwritten text in a large, irregular box, possibly a summary or a specific section of the document. The text is written in a cursive script and is mostly illegible due to the handwriting and the angle of the page. It appears to be a collection of notes or a list of items, possibly related to the vocabulary or grammar sections above.

Advanced Dungeons & Dragons®
Official Game Adventure

Desert of Desolation

An epic adventure includes the revised *Desert of Desolation* series plus totally new adventures within Raurin, a desert wilderness set in the fabulous Forgotten Realms.

by T. Hickman, L. Hickman,
P. Meyers, P. Rice, and J. Wheeler

Deep blue mists of the night swirl over the sands of Raurin, the incomparable Desert Of Dust. As the cool night air drains the heat from the sand, you and your friends huddle around your campfire, glancing nervously at the giant pyramid in the distance.

Gradually, the winds change direction, bearing a thin streak of white mist toward you from the pyramid. It swirls and takes shape as a faceless man dressed in ancient robes and an ornate head-piece; moonlight shining through his ghostly body and robes, he lifts his arms toward the pyramid and speaks.

It was magic that conveyed you all to Bralizar, and an ancient map that guided you through the pass in The Dustwall. But it was, after all, the tales that finally brought you to this place — tales of endless wealth, of spirit-guarded pyramids, of crystalline obelisks, of gemstones with mysterious properties.

Now, as the haunted voice of the spectre before you begins his tale, you wonder if the treasure and the quest are worth the price . . . perhaps your very lives. Are you really the heroes of the prophecies, those who will overcome the foretold tests, and those for whom the treasure awaits? It is time to search your hearts before you venture further into the *Desert of Desolation*.

Designed for use with



©1987 TSR Inc. All Rights Reserved. Printed in the U.S.A.

TSR Inc.
POB 756
Lake Geneva,
WI 53147

TSR UK Ltd.
The Mill, Rathmore Road
Cambridge CB1 4AD
United Kingdom

0-88038-397-6

