

# Wyrmskeep Dungeons TZ1

## Raiders of the Cloud Castle

Written by Joe Pearce

AN ADVENTURE FOR CHARACTER LEVELS 8-10



The final entry in a ranger's journal reveals clues to a terrible secret: wandering horrors from the sky have been ravaging secluded settlements all across the mountains and valleys of the Tanz in the last few years, taking all they can carry and enslaving those that survive the assault. The journal also has a prediction of which village will be the next target of attack: the famed community of Woodsend!

A party of adventurers will heed the warning and embark on a preemptive strike on these **Raiders of the Cloud Castle**™. Will they succeed against the foul creatures within or will the entire endeavor come crashing down on their heads? Literally.

**The Wyrmskeep Entertainment Co.** is dedicated to creating quality and fun games, both traditional and digital! With our tabletop line of products, **Wyrmskeep Dungeons**™, we intend to bring that commitment to the realm of fantasy role-playing games. We hope you and your players enjoy the story and challenges in this module! If you like this adventure, look for other releases.



[wyrmskeep.com/rpg](http://wyrmskeep.com/rpg)

# AVIARY & FIRST TOWER

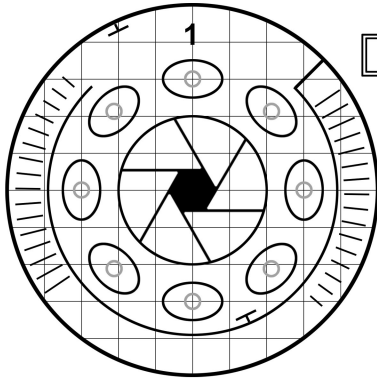

AVIARY

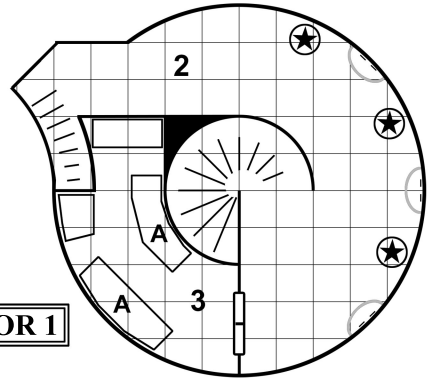

FLOOR 1

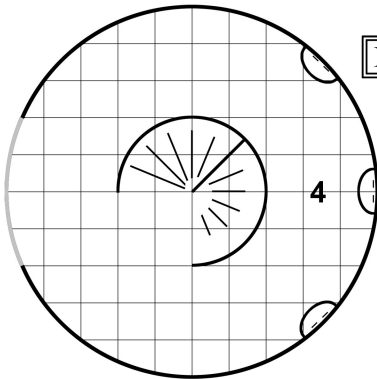

FLOOR 2

□ 10'x10'

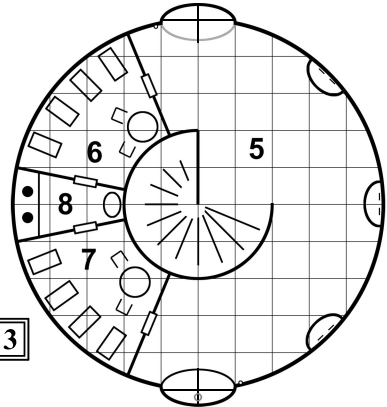

FLOOR 3

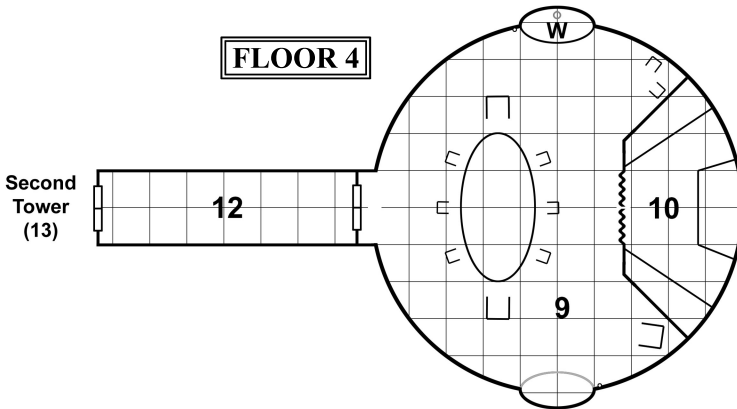

FLOOR 4

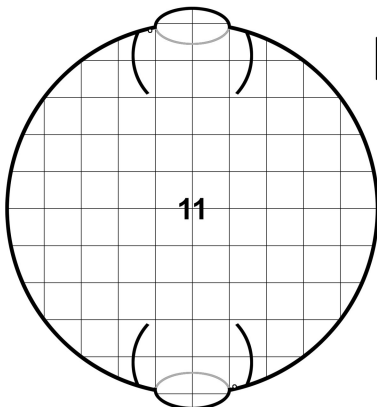

ROOF

## LEGEND

	Medium Door		Furniture
	Huge Door		Crank Wheel
	Huge Double Door		Statue
	Stairs		Lift Here
	Curtain		Lift Not Here
	Handholds and Access Hole		

# Wyrmskeep Dungeons TZ1

## Raiders of the Cloud Castle

AN ADVENTURE FOR CHARACTER LEVELS 8-10

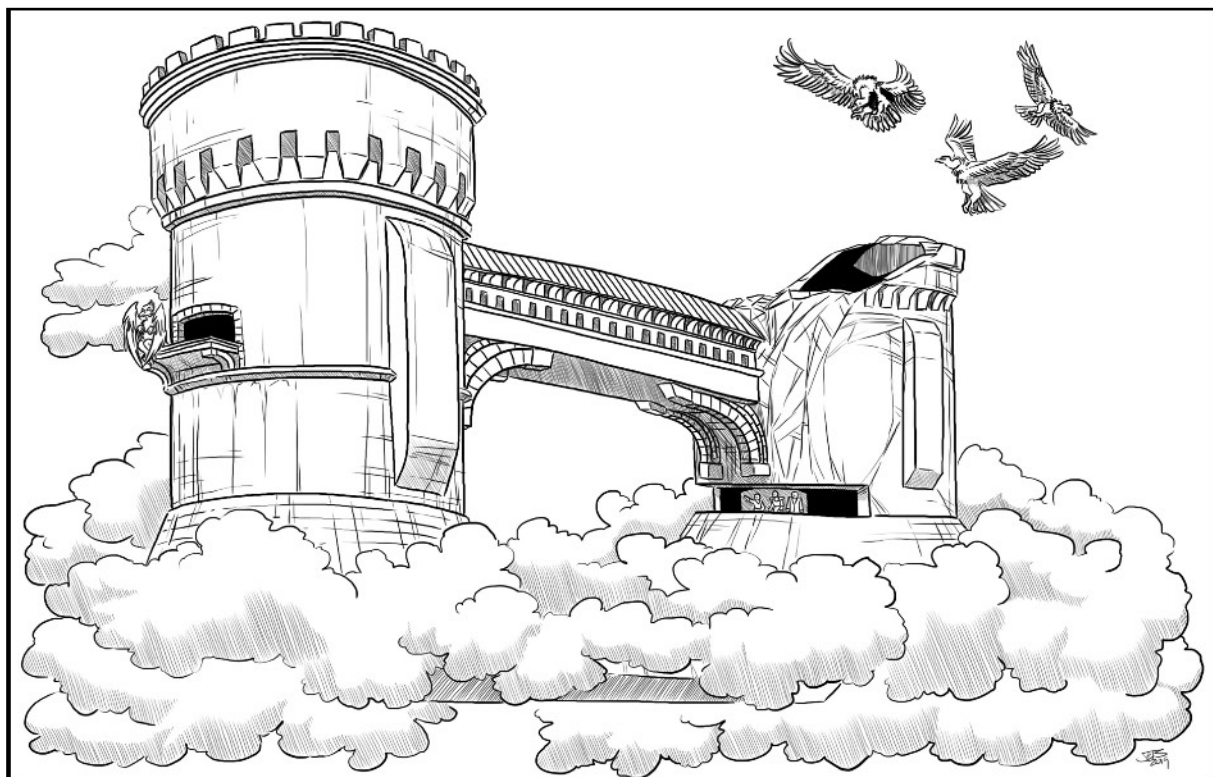

### Credits

Author:	Joe Pearce
Artists:	Jacob Blackmon, Joshua LH Burnett , Ed Lacabanne, Mark Lyons, Brian McCranie, Phil Stone
Cover Artist:	Ed Lacabanne
Cartography/Layout:	Joe Pearce
Proofreading:	John Bowlin, Justin Ryan Isaac, Mark Taormino
Testers:	Jeremy Langdon, Oliver Knox, William Knox, Edward Tu

*Wyrmskeep Dungeons, Raiders of the Cloud Castle, the Wyrms in a Keep logo, and The Wyrmskeep Entertainment Co.* are trademarks of The Wyrmskeep Entertainment Co. Portions of the work are licensed under the Open Game License 1.0a. Email your inquires and comments to [techsupport@wyrmskeep.com](mailto:techsupport@wyrmskeep.com). Additional methods of contacting us can be found on our website.

© 2019 The Wyrmskeep Entertainment Co. • Printed in USA • Version 1

WETZ-001 • [wyrmskeep.com/rpg](http://wyrmskeep.com/rpg)

## AUTHOR'S NOTE

Thank you for purchasing this module! The adventure within contains a challenging set of encounters requiring varied tactics and skill sets, which hopefully you and your players will enjoy!

## GM INFORMATION

This module is designed for a group of 8th to 10th level characters, with a total of 50 to 65 levels. If the party is significantly weaker or stronger than that, you may need to adjust the hit points or number of opponents to compensate. The party should consist of at least two fighters, a cleric, a mage, and a rogue (or similar classes).

The scenario can be ran stand-alone or as part of a campaign. Feel free to change the names of locations to match your game world. FYI, the place names are from my campaign world and appear in other *Wyrmskeep Dungeons* modules!

The stat blocks for non-player characters and monsters can be found at the back of the module, with descriptions of new magic items listed immediately after.

## BACKGROUND

### THE DISTANT PAST

Once upon a time, high in the central mountain range of the great continent, there was a kingdom named **Gangea** ruled by giants, but living in peace with its demi-human inhabitants. To maintain the safety of this unusual society, outsiders were dissuaded from entering this "valley of cooperation" by the use of both cunning illusions and vigilant guards.

The kingdom remained hidden for decades, but whispers of its existence ultimately came to the ears of those who coveted its wealth and strategic position more than its friendship. A mighty army of conquest was mustered, the illusions were breached, and war was waged.

Eventually it became obvious to the Gangeans that they would be vanquished. The leaders would not allow the attackers to gain the spoils of the kingdom, so its mightiest magicians and priests were instructed to cast a doomsday spell that destroyed both sides and the valley itself, and so the land passed into myth.

But one of the kingdom's most unusual creations survived the cataclysm...

## THE RECENT PAST

A couple years ago a pair of **ice giants**, **Cirrus Cloudbender** and **Stratos Ravager**, were seeking shelter during a late winter storm in the fog-covered mountains north of the **Tanz Woods**. By luck they stumbled into what, at first, seemed to be an immense, hewed cave, but further investigation showed that it was, in fact, just one floor of abandoned castle. Exploration revealed that the castle (a) was designed for occupation by both medium and giant-sized creatures and (b) most marvelously, had the power to travel through the sky!

The giants were able to fix-up the castle and get it floating freely in the air again, but they were initially unable to control where it went. In a hidden vault, the giants found a pair of rings set with jade stones that gave the wearer mental control over the motion of the castle.

After that the giants began to consider what to do with their new found home. If they had been scholars, they might have delved into the origin of the castle; but being rapacious, they decided to earn their keep by attacking isolated villages. They recruited various creatures who would be inclined to assist in their nefarious efforts: giant vultures, harpies, amoral demi-humans, etc.

It has been smooth sailing for these raiders of the cloud castle, but now a brave and stalwart ranger has discovered their trail of devastation and intends to warn the next target at all costs!

## PROLOGUE

To begin the adventure, read the players the following boxed text. If you are running this module as part of a continuing campaign, you can and should change details to match how the player's party made their way to Woodsend.

It is morning in the village of Woodsend. Your party spent the night at the Olde Plow Inn located at the southern edge of this village near the road that passed through the area. Your mood, which was already sour after the map you were following failed to lead to the fabled dungeon known as the *Trials of the Tanz Woods*, has only gotten worse with the unexpected overcast clouds that have rolled in from the west. Breakfast isn't much of a winner either.

The monotony is broken by the sound of a galloping horse that stops outside the inn's common room. Through the door rushes a young

man in simple farming apparel, who immediately proceeds to talk with the bartender. They have a short conversation, and the bartender points to your party's table. This should be interesting.

**“Good travelers, would any of you be bold champions against the forces of wickedness?”** One of the party offers a hand nonchalantly and says, **“Please have a seat and tell us of your woes! Bartender, get this man an ale!”** The man, named Issac Steelman, the son of a blacksmith, gladly takes a chair. Between gulps from his mug, he tells you that the mayor has tasked him to find those who would be willing to come to the aid of the village, as there is good information that an attack will occur soon! He thought he would have to ride to nearby villages to find some adventurers, but fortune seems to have favored him and Woodsend.

The party wonders why assistance hasn't been sought from the (relatively) nearby army outpost. Issac rolls his eyes and says, **“It would take days for the army to get approval to send anyone to help, and the mayor says we don't have that time!”**

The party consults among themselves and agrees to talk to the mayor. Issac thanks you all profusely. As you leave the tavern, you try to pay for your breakfast, but the bartender says its on-the-house.

Issac leads the party to one of the few large building in Woodsend. You are ushered into a meeting room and are introduced to **Aethyn Battlestar**, the mayor of Woodsend. He is an older human with a muscular build, but walks with a noticeable limp. A leather pouch rests on the table in front of him.

Aethyn Battlestar is an fighter and adventurer of some renown who retired more than a decade ago because of an injury to his leg that could not be healed because of the cursed weapon involved. Any party member with a passive History score of 14 or better will have heard of Aethyn and the fact he “disappeared” some time ago. If anyone wants to ask the mayor about this, he will confirm his identity and backstory. His lame leg makes him unavailable to join in any assault.

The mayor welcomes you and says, **“Time is of the essence, so I'm going to skip the normal pleasantries. We have learned of a dire**

situation threatening this good village. A farm boy, fishing in a nearby stream, caught something unexpected, a small journal securely wrapped in leather bindings.” He pulls a small book from the pouch.

**“Although you are welcome to review the journal, let me summarize the most salient details for you,”** says Aethyn. **“This journal was penned by a ranger who discovered that settlements in a wide area through the Tanz have been attacked and pillaged in the last couple of years, with everything of value taken and entire populations either captured or slaughtered. The only survivor of these raids that the ranger could find was a lonely hermit who told of terrors that came from the skies: torrential rains that impaired defenders, hideous flying beasts with enticing voices that left men dazed and confused, and strange explosive globes that killed many. The hermit only survived because he managed to hide in a hollow tree stump.”**

Aethyn opens the journal to a one page showing a set of hastily scribbled calculations. **“Based on the pattern and frequency of attacks, the ranger determined that Woodsend would be the next likely target. He was heading here when he realized he was being tracked by foul creatures. He chose to bind this journal tightly in a leather pouch and throw it in a river hoping that it would be found if he did not survive.”**

One of the party asks, **“Where are these creatures coming from?”** The mayor responds, **“Ah. The hermit also mentioned that the raiders collected all the spoils and prisoners below a large dark, foreboding cloud. As best he could hear, one monster said something like “spirituum caeli adtende,” and then everyone and thing beneath the cloud rose slowly into the air and up to the base of the cloud! Hopefully others can do the same and thereby execute a preemptive strike!”**

Aethyn pauses for a moment and then says, **“Time is of the essence! The overcast sky is a harbinger of the raiders arrival, and a cloud as described in the journal has been sighted approaching! The attack usual comes only a few hours after its arrival. Will you undertake this task to put an end to this scourge from above?”**

The player may just say, “Yes,” without further discussion, or that may want to discuss compensation. If the latter, Aethyn will say that the village doesn’t have much money on hand to offer the party for their services, but they can provide some items as pre-payment with the hope they may be of use: a **potion of flying**, a **potion of gaseous form**, and two heavy crossbows modified to fire grappling hook bolts.

Plus, he will sign over the deed to a nice 6 acre property with a large cottage, farmable land, and a creek running through it. He will even be willing to sign the property over *before* the party begins their mission as an incentive. Of course that property becomes worthless if the party doesn’t stop the raiders! The party can also keep any spoils from their raid on the castle.

Shortly after agreeing to the mission, the party finds itself standing below the cloud in question. Everyone checks their equipment in preparation for a possible battle, and then one of your group volunteers to speak the command phrase. The words, “**spirituum caeli adtende**,” are spoken, and slowly the entire party starts to rise into the air! The rate of ascent begins to increase, and you begin to worry that you are moving too fast. About 40 ft. before reaching the cloud base, you suddenly slow down. At the same time, a 60 ft. diameter zone of the cloud clears revealing a large hole, which the party drifts through.

## GENERAL NOTES ABOUT THE CASTLE

**Walls and Ceiling.** The walls appear to be made of white marble, but closer inspection shows them to be composed of some dense, puffy but strong, material. This is “solidified cloud” and impervious to most damage, although a dispel magic (vs. DC 17) might open a 6 ft. diameter hole.

Except for the **Aviary (1)** and the **Roofs (11, 26)**, all areas have 30 ft. high ceilings.

**Doors.** Unless otherwise stated in a description, all doors are made of metal-bound hardwood, have 60 HP, and are locked. Small doors are human-sized and can be unlocked on a DC 11 Lock Picking check, while huge doors are giant-sized and cannot be unlocked using a regular lock-picking kit — the tools are way too small. Conveniently, there will be a separate medium-sized door embedded in any huge door. Huge double doors only have one human-sized door, not two.

**Lifts.** Some floors have lifts that allow access to adjacent floors. Each lift has a short pedestal with three buttons: two green buttons and a red button. One green button bears an up-pointing equilateral triangle (“up button”), while the other has a down-pointing triangle (“down button”). Pressing a green button causes the lift to move up or down to the next floor, which takes 24 seconds (4 turns). The button stays depressed until the next floor is reached or another button is pressed. The red button is an emergency stop. It stays depressed until a green button is pressed.

On the wall to the left of each location where a lift aligns with a floor there is a panel with one unadorned green button. Pressing this will “call” the lift as long as none of the buttons on the lift’s pedestal are pressed. A successful DC 12 Intelligence check will allow one to determine it is possible to hack the “call” control by manipulating the “glowing fibers” behind the easily opened panel. On a DC 15 Lockpicking check the lift controls can be overridden and switched to up, down, or stop. Pulling *out* the fibers will only have the effect of making the button inoperative.

**Outside the Castle.** The castle’s exterior is guarded by a flock of **6 Giant Spiting Vultures** patrolling some 40 ft. above the top of the towers. They will attack any creature attempting to travel between the towers that is not a vulture or a harpy. Anyone who falls outside the castle will either strike a roof or the top of the aviary or bridge, taking 3 (1d6) bludgeoning damage per 10 ft. of fall, or go straight through the cloud layer and strike the ground at terminal velocity taking 105 (30d6) bludgeoning damage.

## 1. IRIS ENTRANCE AND AVIARY

Once entering the hole you are deposited along its edge, inside a large cylindrical room approximately 100 ft. in diameter. The walls and floor are made of a white stone with an unusual texture. The hole you entered through is formed by an open iris also made of stone, which is the only source of light.

What one might call a stairway runs along the room’s wall, but the steps are *huge* and not designed to be climbed by humans or other similar beings. At the base of the stairway is a 6 ft. diameter metal crank wheel set about 8 ft. up the side of the wall of the stairs. A second crank wheel is located on the wall opposite the bottom of the stairs, also set 8 ft. up.

Eight 4 ft. diameter columns rise from the floor. They are arranged in a circular pattern between the iris and the inner wall of the stairs. They widen into 15 ft. by 10 ft. oval shapes after 20 ft. or so.

The floor is splotted here and there with white dust and some solid, dark yellow substance, not necessarily located together. A slight vibration can be sensed from the floor, but the source is not obvious. The room is starting to get darker as the iris closes!

Give the party a chance to ask questions about the room before mentioning the iris has stopped closing, leaving a 10 ft. diameter hole still open. If the party looks upward, tell them that the ceiling is more than 40 ft. above.

The stair-side crank can be turned with some effort to cause the outer edge of the stairs to reform into a series of medium-sized creature steps. The other crank can be turned to either close the iris even more, or open it wider.

If the iris is opened to its full extent and the command phrase, “**spirituum caeli adtende,**” is spoken just before stepping off into the hole, a person or an entire party can safely float to the ground.

The source of vibration, which can continue to be felt throughout the castle, will not be known until the party reaches the **Engine Room (18)**.

Roosting in nests on the platforms at the top of each column are **8 Giant Spitting Vultures**. Once anyone in the party has climbed (or flown) at least 20 ft. up (using the stairs or otherwise) or shoots something at a platform, the vultures will take notice and attack. Do mention the glints of metal on their talons!

When one of the eight nests is searched by the party, roll randomly to determine what treasure can be found:

### Treasure Roll (d20)

**1-2:** Nothing but tattered clothing and colorful, but worthless, stones.

**3-8:** 10d6 gp and 3d10 10 gp gems.

**9-13:** 6d6 pp and 2d10 50 gp gems.

**14-17:** 4d6 25 gp gems, 2d10 100 gp gems, and a **potion of healing**.

**18-20:** 3d6 50 gp gems, 1d6 500 gp gems, and a white marble **stone of good luck**.

Only one stone of good luck will be found. On a second roll of 18-20, there will instead be half the listed gems (round up) and a clear bead of glass that has a magic aura but no actual powers.

## 2. HALL OF STATUES, LADDERS, AND GIANT STAIRS

At the top of the stairs there is a 20 ft. wide and 30 ft. high corridor that leads away from the aviary (for a lack of a better word). It is lit by torches located 10 ft. up the left wall. After 60 ft. it widens to 30 ft. and begins to curve to the right. Immediately to your left and again 40 ft. and 80 ft. along the outer wall are 20 ft. tall statues of human-like figures wearing togas. The first figure holds javelins in one hand and is beginning to throw another downward with the other hand. The second figure has both hands in front of him, one grasping wriggling humanoid shapes while the other is crushing a small keep. The final figure has one arm outstretched while a vaguely bird-like creature perches on it. Between each statue is a series of human-sized hand-holds carved in the walls that lead up to openings in the ceiling.

As the party walks father down the corridor they will eventually see the huge double doors at the end and the central stairway. Read this to the players:

You now get the impression that this corridor is really part of another 100 ft. diameter area that has been divided into at least two rooms. The wall at the end of the corridor has a huge set of double doors. To your right there is a spiral stairway going up, but like the previous room, is for use by giant creatures. You can also see that there is a third set of hand-holds and ceiling opening 20 ft. beyond the final statue.

## 3. STOREROOM

This appears to be a storeroom. It has many shelves on which rest various crates and chests. Barrels sit on the floor. Although there exists a 10 ft. tall ladder allowing access to some higher shelves, a couple of shelves are almost 20 ft. above the floor! Only about a fourth of the space is taken — maybe supplies are running low.

Everything here was acquired by pillaging villages. All the contents are fairly mundane (or so it appears). If the party searches for a particular item or foodstuff one could purchase in

a small settlement, it will be found. The highest shelves hold seven barrels containing premium ales and wines worth 200 gp per barrel to the right buyer.

Napping on the shelves (“A”) above the party’s heads are **two Noxious Anacondas**. Noise of searching the items in the room will rouse them and lead to an attack on the party. They will try to stealthily slither in range to breathe poison gas on their victims and then drop down to attempt to eat some tasty player characters.

On one of the shelves where an anaconda was located is a chest containing fancy dresses that hides a secret compartment. Inside is a **scroll of three spells (floating disk, knock, tiny hut)**.

#### 4. OBSERVATION LEVEL

You take a peek at what is on the next floor. It appears to be another 100 ft. diameter cylindrical chamber. The shaft of the central stairway reaches from floor to ceiling. Natural lighting illuminates the room originating from the opposite side of the room. The handholds continue upward to the floor above.

If the party decides to investigate the room before climbing to the next floor, read the following after they walk around the central stairway.

Sunlight pours in through a large window in the far wall. The view is of a tower made of white stone, 100 ft. wide and almost 200 ft. tall nestled on a large, fluffy cloud. An educated guess would be that you are inside a second such tower. About 80 ft. above, you see a 30 ft. wide bridge connecting the two towers. Other than an opening into the central stairway, which appears to continue up to the next floor, there is nothing else of interest here.

#### 5. LIFTS AND SERVANTS

The next level of the tower is broken into at least a few rooms as you can see regular-sized doors in the center of two walls a little more than halfway around the central stairway. The huge stairs end on this floor. The handholds also end here. Just before each door on the adjacent walls are 20 ft. wide alcoves some 20 ft. deep. On the left side of each alcove there is a glint of something green. More surprising are the two male humans, wearing simple, clean peasant clothing, standing in front of the stairwell. They



were in some conversation, but quickly stop speaking and turn to stare when you make your presence known!

The two humans, named **Ivan Klog** and **Bo** (just “Bo”), were captured in previous raids and forced to become servants. Their continued survival is based on timidity and being pretty good cooks. They are deep in the throes of Stockholm Syndrome, and an adventuring party being here pretty much freaks them out. If interrogated, they will give very terse, but accurate answers. They will not *volunteer* any useful information though. Any plan of escape proposed by the party will be rejected out-of-hand as “pointless” or “too dangerous.” Each has a key to the **male dormitory (6)**, but nothing else of value.

Both doors are locked. For information on the “alcoves” see the notes about the **Lifts** under **GENERAL NOTES ABOUT THE CASTLE** above. Only the southern lift currently works — the witches on the **floor above (9)** have hit the **stop** button on the northern lift. If the party tries to use the northern lift, the humans will suggest they use the southern lift, as the other *must* be in use.

#### 6. MALE DORMITORY

This 30 ft. square-ish room is decked-out as a dormitory. There are four beds arranged around



the right-side wall, with a trunk set at the foot of each. A single 10 ft. diameter wooden table surrounded by a few chairs sits against the left wall. There is a door at the opposite end. A male gnome wearing simple peasant clothing lies in one bed. He may be sleeping.

**Nicorin** the gnome is indeed sleeping. His attitude is similar to the two humans the party met earlier, maybe even more so since he has been a captive longer. His job is mainly to clean the castle, including scrubbing down the **aviary (1)** and **harpy roost (14)**. Yech! The trunks only have simple possessions of the male captives. The door is not locked.

## 7. FEMALE DORMITORY

This 30 ft. square-ish room is decked-out as a dormitory. There are four beds arranged around the left side walls, with a trunk set at the foot of each. A single 10 ft. diameter wooden table with a few chairs sits against the right wall. There is a door at the opposite end. A woman and two female gnomes are sitting at the table talking.

The two gnomes are named **Hesmila** and **Dolphina**. They are fairly average for their race and have the same attitude as the two humans the party previously met. Their main job is cleaning the castle just like the male gnome. Dolphina also preforms maintenance as she is mechanically inclined.

The human woman is **Varsity Mul**, the daughter of Count Wolfram Mul of Altatanz. She was visiting one of her father's smaller estates in a mountain valley when it was attacked and destroyed. Although she will act like the others at first, asking Varsity about her origins will rekindle her desire for freedom. If the party learns who she is and successfully reunites her with Count Mul, they will earn a reward of 2500 gp! She has won the favor of the giants and so her primary job is acting as their personal servant like the two elves — see **Throne Room (25)**.

The trunks only have simple possessions of the female captives. The door is not locked.

## 8. LAVATORY

The door leads into a thin room with a door opposite. A solid bench made of dark stone stands along the outer wall. It has two circular holes at the top. A metal basin full of water is attached to the inner wall. Well-worn towels hang beside the basin. You guess this is some form of

indoor lavatory. There is a slight draft in the direction of the holes.

This is indeed a lavatory. It uses magical, wind-powered plumbing to remove accumulated waste from use of the holes. The **basin** is also magical. Washing oneself with water from it (even just a face) will grant **5 (2d4) temporary HP** that last 8 hours! This basin's magic is tied to the castle and so will be destroyed if removed.

## 9. BUBBLE, BUBBLE, TOIL AND TROUBLE

The ceiling opens as the lift ascends, two sections sliding away in opposite directions. When the lift reaches the next floor, you find that most of the room is taken up by a 40 ft. long and 20 ft. wide, ornately carved, wooden table. It is very tall, obviously intended for giant humanoids, but has accommodations to also seat medium-sized beings. Two huge chairs have been placed at both ends, with smaller "high" chairs between. Extra chairs can be seen in a couple of corners of the room. A separate area exists to one side, with a large, closed curtain allowing access., but preventing a view of its contents. There is a set of huge double doors opposite the side area. It looks like the lift can be used to travel up to another floor.

If a player asks if the double doors might lead to the bridge between the towers, you can confirm that their theory would make sense.



The lift on the far side is currently stopped halfway between this floor and the next higher. This fact is not obvious given the lift's position above the party's viewpoint, but it will be clearly noticed by anyone who says they look up or asks about the other lift.

On the lift at “W” are **three Witches (Hecate, Galinthias and Selena)** and a cauldron (see below). The witches are clerics of **Lupocs**, the goddess of disease and swamps. Each has a pouch with 10 (3d6) 50 gp gems.

They are initially crouched down so as to be less conspicuous. When the party gets about halfway into the room, they will stand and try to get the drop on some party members — roll for surprise, DC 14 Perception check to avoid.

The witches stand behind a cast-iron **Cauldron of Ball Lightning**. The cauldron can create large bubbles with varied powers. See the **New Magic Item** section at the end of the module for details. The witches have already created two balls each, one floating within 5 ft. and another 20 ft. away in a defensive pattern.

There is nothing extraordinary about the table or chairs. The double doors are unlocked and **do not** have embedded smaller doors, but do have long ropes attached to them to allow medium-sized creatures to pull them open. The curtains lead to the **Kitchen (10)**.

## 10. KITCHEN

This room has everything one would want in a kitchen, although with some duplication given that there are work spaces sized for medium and

huge humanoids. This includes different sized bowls, pans and cutlery. There is a wood-fired stove at one end.

Some of the over-sized cutlery might make a good sword, but the party likely has better weapons than that.

One of the human-sized knives will detect as magic. This is **Dancing Cutlery** (see the **New Magic Item** section at the end of the module).

## 11. FIRST TOWER ROOF

As the lift rises, the ceiling once again parts, but the space above is only 20 ft. high. You find you are in a small half-dome with an exit to what appears to be this tower's roof. From here you can see that the other tower continues up at least one more floor. Maybe this tower was once taller — it seems to have suffered some kind of structural damage in the past and then partially repaired. Some large black birds fly high above. They could be more vultures.

There is nothing else of interest. If the party tries something tricky to get to the other tower from the roof, consult **Outside the Castle** under **GENERAL NOTES ABOUT THE CASTLE** above.

## 12. WINDY BRIDGE

The door opens onto on 30 ft. wide bridge that stretches some 80 to 90 ft. to the other tower. The bridge is enclosed, with a ceiling 25 ft. above. Along the walls are 1 ft. wide and 10 ft. tall openings spaced 10 ft. apart. Sound of a strong wind rushing through the openings can be



heard. At the far side is another large set of double doors.

The wind on the bridge gets progressively stronger as one travels across (DC 20 Athletics check to reach other side, one roll per person). This is where those crossbow/grappling hook combos would be useful. Crossing via a rope may be difficult but will always succeed, even it takes a bit of effort. A wind control spell or dispel magic would be effective too.

### 13. THE SMELL OF FEAR

This chamber is dark and very drafty for some reason. Maybe it has to do with the magicks from the bridge. There are two lifts that appear to go up and down. The floor has three large circular indentations, each sealed by an iris. There is a crank wheel set horizontally in a pedestal at the center of the room. 10 ft. high triangular platforms jut out from the walls between the indentations. There are also fragments of bones lying about.

While you are considering what to do next, the draft subsides. Simultaneously, all the irises begin to quickly open! In addition to light streaming from the holes, a creature with the appearance of a hybrid of a human woman and a hawk flies out of each. A stench that almost makes you retch follows them. All are wearing form-fitting hide armor and holding clubs. You get a sense from the sounds below that there are even more of these foul beasts.

The one at the rear points at the party and screeches, **“Good news, ladies. Our killing spree gets to begin early! Destroy the intruders!”** You notice she is wearing gauntlets.

There are a total of **8 Battle Harpies**. Their leader, who acts as spokes-monster, wears **Gauntlets of Hill Giant Strength** giving her 21 STR, +7 to hit, claw hit of 10 (2d6+5) slashing damage, and club hit of 7 (1d4+5) bludgeoning damage.

When only one harpy is left alive, she will cackle, **“You may have won this fight, but more of my sisters will be arriving soon to join the upcoming rampage! Flee! Flee while you still can!”** She will then attempt to escape via the balcony and fly to meet these other harpies. GM’s decision on how this plays-out if any party members try to follow her.

### 14. HARPY ROOST AND BALCONY

After defeating the harpies you get a chance to take a good look at this area. It’s just one large room with the floor littered by stained rugs, quilts, rags, and vines organized into a number of nests. The place reeks of urine. Along a fourth of the wall facing away from the other tower is a balcony that allows access to the outside — the source of the light from earlier. The two lifts only travel down to this floor, but descending further is a stairway with huge steps located opposite the balcony. Some wooden ladders are piled near the stairs.

The harpies’ belongings are kept in sacks hidden within their disgusting nests. There are eight sacks containing in total 10,000 sp, 2,000 gp, gems and jewelry worth 3000 gp, and two vials. One is a **Potion of Diminution** and the second is a **Philter of Love**. In a pile of harpy excrement is a **Ring of Free Action** that will likely only be found by using *detect magic*.

The ladders can be propped against the stair steps to allow medium-sized features to climb down to the next floor.

### 15. GATES

At the bottom of the stairs is a metal-barred gate preventing immediate access to the next floor. A small amount of light filters in from the floor above, giving you a good view at what is beyond the gate: an archway opening into a room about 20 ft. ahead, and another gate just to the right. The vibration you felt when you first set foot in the castle, but have gotten used to at this point, is much more pronounced here.

Both gates are locked but can be opened by the keys held by the elf guards in **Throne Room (25)**. The locks can be picked on a DC 14 Lock Picking check, and the bars can be bent to allow squeezing between them on a DC 18 Athletics check.

### 16. DUNGEON OFFICE

Through the archway is an office. It is approximately 40 ft. long by 20 ft. wide, with two large chairs at each end and a semicircular desk placed against the outer wall between the chairs. There is a painting of a snowy mountain range hanging above the desk, and large red and brown circular rugs on the floor under each chair.



The desk has one drawer. It is easily opened to reveal three parchment scrolls, some quills, an inkwell, a metal ring of keys, and a leather pouch. The parchments have a running total of the number of prisoners in the cells, with each previous total being crossed out. The numbers range from 2 to 54, with the current, uncrossed-out number being 3. The keys open the cells on this floor. The pouch contains 43 sp and 18 gp.

Hidden under the rug below the far chair is a large, wooden trapdoor with a metal ring. When pulled open, it reveals a short passage leading to the **Engine Room (18)**.

## 17. CORRIDOR AND CELLS

Beyond the second gate is a corridor that circles the central core of the floor in a hexagonal arrangement. There are six human-sized doors along the inner wall, and three large-sized doors on the outer. Each door has small, barred windows that allow viewing into the room on the other side. The large-size doors have two such windows positioned for both medium and large creatures. Dim torches light the corridor.

Looking through a window will reveal a cell. All have scraps of blankets and other debris piled randomly around, making it hard to determine if any are occupied. None of the cells have anything of value, but some are inhabited.

The large cell marked with a “**C**” contains a centaur named **Akritos Ly**. He is sleeping in the far corner — opening his cell will awaken him. Akritos will be very belligerent until convinced the party is not in league with the raiders. (Note: he only speaks elven and sylvan.) If convinced to tell how he came to be imprisoned, read the players the following:

**“I was traveling along a trail at the top of a tall hill when a large, dark, ominous cloud passed only a few dozen yards overhead. I gave it no mind initially, since fog is not that unusual at that elevation, but then I heard a loud, flapping sound from above. I was attacked by three grotesque women-birds! They used a weighted net to subdue me, and I was carried into this castle in the clouds and thrown into this cell!”** What an unlucky centaur! In the wrong place at the wrong time!

Akritos is in fairly good shape. If asked to join the party and given an appropriate weapon, he

will gladly tag along and seek revenge on his captors.

The small cell marked with an “**H**” holds a male human curled up in one corner of the cell. He is basically skin-and-bones, has scraggly white hair and a beard, wears vile smelling scraps of fabric as clothing, is unable to walk on his own more than 10 ft., and delirious. When asked a question, he will give a non-sequitur answer. The only name he responds to is **Bub** — who knows if that has anything to do with his real name.

Another small cell of interest is marked with a “**G**” and is inhabited by a male gnome, **Jorgim**, who was a simple merchant. Although he has been imprisoned in this dungeon for some time and has a ragged appearance, his gnomish resilience has kept him in much better shape than “Bub.” He can walk on his own and can speak rationally, if haltingly, but is in no shape to fight. When an attempt is made to talk to Jorgim, read the following to the players:

The gnome says, “**Are you here to rescue me? Thank the gods! Please help me up.**” He reaches up towards you, but you notice that something is amiss. His shadow is misshapen and the shadow’s hand is composed of claws instead of fingers! What devilry is this?

Unfortunately, the gnome is currently “infected” by a strange monster called a **Shadow Creeper**. The creeper will immediately attack the party, using its initial bonus action to create shadow fragments in the shadows of up to four party members it can see.



## 18. ENGINE ROOM

A metal ladder leads down from the trapdoor. Once there is a clear view of the room below, you are met with an awesome sight. Except for a clear path around the edge, the room is filled by a huge, rotating mechanism! A 5 ft. shaft runs from floor to ceiling at the center, and four 35 ft. long arms made of a silvery metal extend from the shaft outwards. Each arm is covered in hundreds, if not thousands, of white feathers of various lengths and types. The upper two arms are quickly rotating clockwise around the shaft, while the bottom two rotate counter-clockwise. All the feathers are bent backwards as the arms rotate. This is obviously the source of the vibrations you have been feeling throughout the castle.

This “engine” is a magical device that sucks energy from the Elemental Plane of Air and uses it to levitate and propel the castle. The arms are made of a dense, hard wood with silver-plating. Casting *detect magic* on the engine will reveal transformation magic. The arms are rotating at a speed of one revolution per two seconds.

Stopping both sets of arms (or breaking them!) is nigh impossible and would be catastrophic, as the castle would instantly fall from the sky doing fatal damage (no saving throw) to anyone inside when it hits the ground. Slowing the rotation isn't much better, as it would cause the castle to become unstable and pitch from side-to-side randomly. If a character insists on trying to stop an arm, let them try. DC 25 checks are appropriate with failure causing an arm to slam into the character doing 45 (10d8) bludgeoning damage.

On the opposite side of the room can be found the skeletal remains of a halfling (“B”). His clothes are tattered, but his boots are intact. Hidden in the heel of one boot is a set of minimal lock-picking tools, while in the heel of the other boot is three 100 gp gems.

## 19. HALL

The lift travels to the next floor, which appears to be the last stop. You are at one end of a large hall. On the outer edge is stairs that lead up to the next floor. Both giant and human-size steps are visible, surely the result of someone having already turned a metal crank wheel on the wall near the base of the stairs. Opposite is a multi-section wall. The middle part has a convex,

semicircular shape with two human-sized doors. The remaining sections are straight, each with a giant-sized door.

There is nothing else of interest in the hall.

## 20. WALK-IN CLOSET

This vaguely triangular room has a number of shelves attached to the walls. On the shelves are clean, white linens with purple trim.

The linens come in both medium- and huge-size. If they were not so heavily used, they might be worth 500 gp in total. Instead, they really don't have much value.

## 21. ELVES' QUARTERS

This vaguely triangular room is furnished as a simple sleeping quarters. Two medium-sized hammocks, one atop the other, hang from a wooden frame along one wall. A thin ladder gives access to the upper hammock. A pole stretches between two corners, on which hangs fine clothing of elven design. A small table near the door holds a washbasin and some towels. Various small holes in the walls give the party the impression this was once a storeroom or utility closet that has been repurposed.

The giants' two elf guards live in this room. Beneath the clothing rack is a small, invisible chest. If that area is searched, the chest will be found by bumping against it. The chest is locked via a slide puzzle which requires a DC 14 Dexterity check to open *if the chest is not invisible!* Otherwise, there is disadvantage on the check. Once opened, the interior of the chest is visible. Inside are two pouches (each containing 100 gp and five 50 gp gems), two silver daggers, and an **Apparatus of Mutual Recall** (see **New Magic Items** section) with its target destination set to a location near the border to the elves' homeland.

## 23. CIRRUS CLOUDBENDER'S BEDROOM

You have entered a bedroom with giant-sized furniture: a round table and chair to the right and a simple bed with large pillows and a quilt situated along the far side. The pillow and quilt are white and trimmed in purple. A large painting hangs on the left wall. It portrays a blue-skinned male human-like being (probably a giant) with blond hair wearing a toga sitting on a white stone throne.

A cabinet is built into the underside of the bed. Inside are large, clean togas. The togas, pillows, and quilt are monogrammed with “**CC**” in the Giant tongue.

Behind the painting is a secret door that can be revealed on a DC 12 Investigation check. The door is locked, but the successful check above will reveal that a brick can be removed to reveal a lock. This lock can only be unlocked simultaneously with the one in **Stratos Ravager’s Bedroom (23)**. Without the key, it requires a DC 15 Lock Picking check to open IF someone also succeeds on a similar check on the other lock. As there is a solid wall between the bedrooms, synchronization may be difficult. A failure on either check will prevent opening the locks at all for 5 minutes.

Cirrus has the key to this lock. If the key is inserted, the other lock will vibrate for a moment, allowing easy synchronization.

### 23. STRATOS RAVAGER’S BEDROOM

You have entered a bedroom with giant-sized furniture: a round table and chair to the right and a simple bed with large pillows and a quilt situated along the far side. The pillow and quilt are white and trimmed in purple. A large painting of a blue-skinned male humanoid being (probably a giant) with blond hair wearing a toga in a pose of firing a bow hangs on the right wall.

A cabinet is built into the underside of the bed. Inside are large, clean togas. The togas, pillows, and quilt are monogrammed with “**SR**” in the Giant tongue.

Behind the painting is a secret door that is identical, but mirror reversed, to the one in **Cirrus Cloudbender’s Bedroom (22)**. Consult that area’s description for details about the secret door. Stratos has the key to this door’s lock.

### 24. GIANT’S TREASURE VAULT

Beyond the door from the bedroom is a triangular room. A semicircular, 8 ft. tall table lies against the far wall. Even without getting a better view of the top surface, you can see a number of wooden boxes with metal bracing stacked on the table.

There are six boxes. Five of the boxes are locked (DC 12 Lock Picking check to open) and

contain treasure. Box 1: 10,000 cp. Box 2: 8,000 sp. Box 3: two sacks, one holding 5,000 cp and the other with 3,000 gp. Box 4: a sack with 4,000 sp; and a small, cloth-lined metal box (unlocked) with 5 pieces of jewelry with 500 gp each. Box 5: a sack with 2,000 ep; a pouch with 250 pp; a small, cloth-lined wooden box (unlocked) with **6 potions of healing**; and a **bag of beans** with 5 (2d4) beans.

The final, smallest box is not locked, only latched. The interior is lined in protective felt and designed to hold two large rings. These would be the rings that Cirrus and Stratos are wearing. Hidden beneath the felt is a small book written in archaic Common which summarizes the history of Gangea, including a chapter on the construction of the cloud castle. This extremely rare book could be worth 500 gp to the right collector!

### 25. THRONE ROOM

This level of this tower is just one large room. And quite the room it is! There is a large platform on which sits two enormous thrones of white stone, with a short set of steps lead up to it. On the thrones sit two giants. They have pale, blue skin, blond hair, and are clean shaven. Both wear similar clothing: an off-white toga with purple trim, leather sandals, a wreath made from tree branches across their brow, and on one finger a ring set with a large jade stone. They both look a little bored. Beside both thrones are a greataxe (in easy reach) and a perch on which sits a giant vulture. A third such bird is standing on a perch located along the far wall to the left of the platform. Two fires, with iridescent blue flames, burn in stone receptacles to the sides of the platform. Finally, two elves in white, purple-trimmed robes stand in front of the platform. You can see chainmail and a breastplate under the robes. The nearest elf looks at the party and says with authority, in Common, “**Hear ye, hear ye! Small, foolish beings seek an audience with the great and powerful Masters of the Sky, Cirrus Cloudbender and Stratos Ravager. Inform me of why you should not be immediately destroyed for your presumption, and then maybe the Masters will choose to entertain your pleas.**” One of the vultures squawks loudly.

Sitting on the thrones are the rulers of the castle, **2 Ice Giants (“G”)**. They always call each other “brother” even though they are only distantly



**end!”** He will smash his hand to the floor shattering the jade gem in his ring. The other giant’s gem will also shatter, and then the whole castle will violently shake and slowly begin to crack and crumble. The party now has approximately 15 minutes to evacuate the castle before it completely loses integrity and falls from the sky! This should be long enough to collect the treasure from the **Vault (24)** with the giant’s keys (although not time to immediately inspect the contents of the boxes), gather all the (known) captives, and exit through the **Aviary (1)** or possibly another exit. This time limit can be properly guessed with a successful DC 12 Survival or Investigation check.

Attached to the wall opposite the platform is a giant-sized iron ladder. It lead to the ceiling where a trapdoor, made of the same materials as the castle’s walls, can be found. There is a latch that can be pulled to allow pushing the trapdoor open upward, giving access to the **Roof (26)**.

## 26. SECOND TOWER ROOF

You are on the roof of the tower. Not unlike a normal tower, it has battlements along the edge. The difference is that they are taller as befitting a castle made for giants. Impressive!

If the party reached this roof first from the outside, they will be able to determine that there is some kind of trapdoor allowing access to the castle interior, but no obvious way to open it. A DC 15 Investigation check can determine the location of the latch on the opposite side. It is difficult, but not impossible to unlock the latch from this side — a DC 20 Lock Picking check will do. Finally, a DC 15 Athletics check is needed to get a good enough grip on the door to pull it upwards and open.

## EPILOGUE

As long as the party doesn’t delay in opening the vault and rescuing the captives, allow them to escape before the castle falls to the ground. You are welcome to have the castle lurch occasionally to enhance the urgency. Once on the ground, give the party time to run from under the falling castle! The castle will be completely destroyed once it strikes the ground, probably making quite the crater!

They will be greeted by the village folk, and the mayor will hand over the deed to the cottage and land he promised the party (if he didn’t do so

related. Each has the key to the secret door in their room hanging from a high-quality silver chain hanging on their neck. The chains are worth 50 gp each.

The three birds are indeed more **Giant Spitting Vultures (“V”)**. They are pets of the giants, and each wears a collar made of woven platinum and encrusted with sapphires worth 1000 gp each. If a vulture takes more than 25 HP damage in one hit, the sapphires will be destroyed, reducing the collars value to 200 gp.

Finally, there are the **two elf guards (“E”)**. They were presented as part of “tribute” paid to the giants by the “Deep Lord of the Forest” to save their land from the raider’s rampage. The two elves act as chancellors to the giants.

Some of the stones making up the stairs to the thrones are loose and can be thrown by the giants.

If both giants are killed, the last one will survive long enough to say, **“Your victory here will be short lived! With my final breath let this all**



earlier). The property can be sold for at least 5,000 gp to the right buyer, or the party can make the cottage their base of operations (and maybe hire some laborers to farm the property). How much downtime have they accumulated?

Although the human authorities consider the deed valid, the nearby elves may disagree. That is an adventure, of sorts, for another day.

If the GM wants an extra heartwarming event, the ranger who wrote the journal can arrive in the village shortly after the raiders are defeated. He or she will be battered, but happy to have completed their personal mission. The ranger's name, race and gender can be chosen by the GM, as the journal does not include any of that information!

### BONUS EXPERIENCE POINTS

Each surviving party member should receive the following bonus experience points:

**6000 XP** if the giants are killed, thereby ending the threat of the raiders.

**100 XP** for each captive rescued alive, including the elves. If Akritos Ly, the centaur, chooses to assist the party and dies in battle, he still counts!

### BUILDING ON THIS ADVENTURE

If the party recovers the history of Gangea book from the giant's vault, the GM may want to consider creating an adventure where the party tries to locate the ruins of that civilization. Who knows what wonders and dangers might be found there!

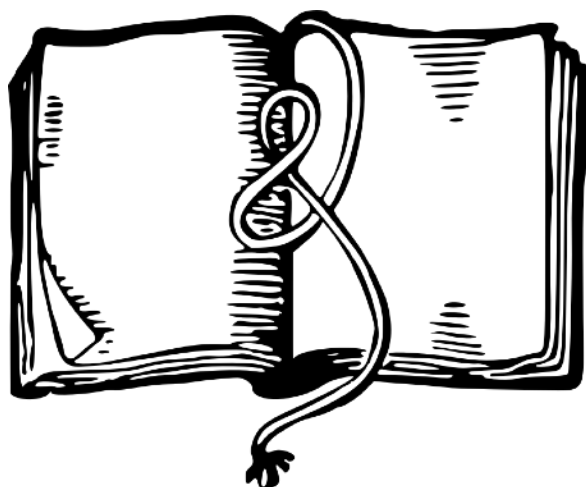

## NPC DESCRIPTIONS

### Witches (Hecate, Galinthias & Selena)

*Medium humanoid (human), chaotic evil*

*Female 6th level Cleric (Corruption Domain)*

**Armor Class:** 15 (studded leather)

**Hit Points:** 51 (6d8+18)

**Speed:** 30 ft.

STR	DEX	CON	INT	WIS	CHA
10 (+0)	16 (+3)	16 (+3)	10 (+0)	16 (+3)	12 (+1)

**Saving Throws:** Wis +6, Cha +2

**Skills:** Insight +6, Religion +3, Persuasion +6, passive Perception 16

**Languages:** Common, Giant, Orc.

**Challenge:** 2 (450 XP)

**Channel Divinity.** The witch can turn undead one time before a rest.

**Poison Weapon.** After successfully striking a target with a slashing or piercing weapon, the witch can attempt to also poison the target.

Failing a check vs. the witch's spell save DC causes the target to suffer the *poisoned* condition. The witch can only use this ability against any particular target once per long rest.

**Spellcasting.** *Spells prepared (slots):* Cantrips: *guidance, resistance, sacred flame, thaumaturgy*; 1st level (4): *bane, command, guiding bolt, healing word, hideous laughter, inflict wounds, protection from evil and good, sanctuary*; 2nd level (4): *blindness/deafness, enhance ability, hold person, ray of enfeeblement, silence, spiritual weapon*; 3rd level (3): *dispel magic, stinking cloud, vampiric touch.*

### Actions

**Mace.** *Melee Weapon Attack:* +3 to hit. *Hit:* 3 (1d6) bludgeoning damage.

### Bonus Actions

**Stir Cauldron.** A witch can stir the cauldron of ball lightning to generate an additional bubble if she is within 5 ft. and currently controls less than two bubbles.

The three witches worship **Lupocs**, a major goddess of swamps, disease, and stagnation. She is neutral evil, but her clerics of different sects can be any evil alignment or neutral. Her holy symbol is composed of three horizontal lines, representing stagnant water, preferably made of jade. Her clerics prefer to be known as witches, even the male ones!

## Centaur (Akritos Ly)

*Large monstrosity, neutral good*

**Armor Class:** 12

**Hit Points:** 45 (6d10+12)

**Speed:** 50 ft.

STR	DEX	CON	INT	WIS	CHA
18 (+4)	14 (+2)	14 (+2)	9 (-1)	13 (+1)	11 (+0)

**Skills:** Athletics +6, Perception +3, Survival +3, passive Perception 13

**Languages:** Elven, Sylvan

**Challenge:** 2 (450 XP)

**Charge.** If Akritos Ly moves at least 30 feet straight toward a target and then hits it with a pike attack on the same turn, the target takes an extra 10 (3d6) piercing damage.

### Actions

**Multiattack.** Akritos Ly makes two attacks: one with his pike and one with his hooves or two with its longbow.

**Hooves.** *Melee Weapon Attack:* +6 to hit, reach 5 ft., one target. *Hit:* 11 (2d6 + 4) bludgeoning damage.

**Pike.** *Melee Weapon Attack:* +6 to hit, reach 10 ft., one target. *Hit:* 9 (1d10 + 4) piercing damage.

**Longbow.** *Ranged Weapon Attack:* +4 to hit, range 150/600 ft., one target. *Hit:* 6 (1d8 + 2) piercing damage.

Akritos Ly has no weapons when encountered. He is limited to one Hooves attack until given a pike or longbow and can only use his charge feature if he has a pike.

## Ice Giants (Cirrus Cloudbender & Stratos Ravager)

*Huge giant, lawful evil*

**Armor Class:** 16 (natural armor)

**Hit Points:** 159 (13d12+65)

**Speed:** 30 ft.

STR	DEX	CON	INT	WIS	CHA
23 (+6)	13 (+1)	21 (+5)	12 (+1)	13 (+1)	14 (+2)

**Saving Throws:** Dex +4, Con +8, Wis +4

**Skills:** Athletics +12, Perception +4

**Senses** darkvision 60 ft., passive Perception 14

**Languages:** Common, Giant

**Challenge:** 8 (3,900 XP)

**Winter Camouflage.** The giant has advantage on Dexterity (Stealth) checks made to hide in snow and icy terrain.

**Innate Spellcasting.** The giant's spellcasting ability is Charisma. It can innately cast the

following spells, requiring no material components:

At will: *detect magic*, *prestidigitation*, *ray of frost*  
2/day each: *see invisibility*, *sleet storm*, *slow*  
1/day each: *hold monster*, *ice storm*

### Actions

**Multiattack.** The giant makes two greataxe attacks.

**Greataxe.** *Melee Weapon Attack:* +9 to hit. *Hit:* 19 (2d12+6) slashing damage.

**Rock.** *Ranged Weapon Attack:* +9 to hit, range 60/240 ft., one target. *Hit:* 22 (3d10 + 6) bludgeoning damage.

Ice giants are related to both storm and cloud giants. They are slightly taller than a storm giant (22 ft. tall), but have lesser magical powers than a cloud giant. Their blueish skin is a bit thicker though.

Individual ice giants can be either lawful good or lawful evil. Cirrus and Stratos are of a malevolent bent. It is indeed possible that the giants who lived in Gangea were of the good variety.

Ice Giants, but not Cirrus or Stratos, are Open Gaming Content.

## MONSTERS (Open Gaming Content)

### Giant Spitting Vulture

*Large beast, unaligned*

**Armor Class** 11

**Hit Points** 25 (3d10+9)

**Speed** 20 ft., fly 60 ft.

STR	DEX	CON	INT	WIS	CHA
15 (+2)	12 (+1)	16 (+3)	6 (-2)	12 (+1)	7 (-2)

**Senses** Perception +3, passive Perception 13

**Languages** -

**Challenge** 2 (450 XP)

### Actions

**Multiattack.** The vulture makes two attacks: one with its beak and one with its talons.

**Beak.** *Melee Weapon Attack:* +4 to hit, reach 5 ft. *Hit:* 7 (2d4 + 2) piercing damage.

**Metal-capped Talons.** *Melee Weapon Attack:* +4 to hit, reach 5 ft. *Hit:* 12 (3d6 + 2) slashing damage.

**Spit (Recharge 6).** The vulture can spit a sticky, yellow goo at one target within 15 ft. The target must make a DC 12 Dexterity save or have disadvantage on attacks and physical ability checks. Spit can be removed by using an action to wash-off with alcohol.

## Noxious Anaconda

*Large beast, unaligned*

**Armor Class** 12

**Hit Points** 52 (8d10+8)

**Speed** 40 ft.

STR	DEX	CON	INT	WIS	CHA
19 (+4)	14 (+2)	12 (+1)	1 (-5)	10 (+0)	3 (-4)

**Damage Resistances** poison

**Skills** Perception +2, Stealth +4

**Senses** blindsight 10 ft., passive Perception 12

**Languages** —

**Challenge** 2 (450 XP)

### Actions

**Bite.** *Melee Weapon Attack:* +6 to hit, reach 5 ft., one creature. *Hit:* 11 (2d6 + 4) piercing damage.

**Constrict.** *Melee Weapon Attack:* +6 to hit, reach 5 ft., one creature. *Hit:* 11 (2d6 + 4) bludgeoning damage, and the target is grappled (escape DC 16). Until this grapple ends, the creature is restrained, and the snake can't constrict another target.

**Poison Breath (Recharge 6).** The anaconda exhales poisonous gas in a 20-foot cone. Each creature in that area must make a DC 12 Constitution saving throw, taking 21 (6d6) poison damage on a failed save, or half as much damage on a successful one.

---

## Battle Harpy

*Medium monstrosity, chaotic evil*

**Armor Class** 14 (hide armor)

**Hit Points** 52 (8d8+16)

**Speed** 30 ft., fly 40 ft.

STR	DEX	CON	INT	WIS	CHA
10 (+0)	15 (+2)	14 (+2)	9 (-1)	10 (+0)	13 (+1)

**Senses** passive Perception 10

**Languages** Common

**Challenge** 2 (450 XP)

### Actions

**Multiattack.** The harpy makes two attacks: one with its claws and one with its club.

**Claws.** *Melee Weapon Attack:* +4 to hit, reach 5 ft., one target. *Hit:* 7 (2d4 + 2) slashing damage.

**Club.** *Melee Weapon Attack:* +4 to hit, reach 5 ft., one target. *Hit:* 4 (1d4 + 2) bludgeoning damage.

**Luring Song.** The rock harpy sings a magical melody. Every humanoid and giant within 300 feet of the harpy that can hear the song must

succeed on a DC 11 Wisdom saving throw or be charmed until the song ends. The harpy must take a bonus action on its subsequent turns to continue singing. It can stop singing at any time. The song ends if the harpy is incapacitated.

While charmed by the harpy, a target is incapacitated and ignores the songs of other harpies. If the charmed target is more than 5 feet away from the harpy, the target must move on its turn toward the harpy by the most direct route, trying to get within 5 feet. It doesn't avoid opportunity attacks, but before moving into damaging terrain, such as lava or a pit, and whenever it takes damage from a source other than the harpy, the target can repeat the saving throw. A charmed target can also repeat the saving throw at the end of each of its turns. If the saving throw is successful, the effect ends on it.

A target that successfully saves is immune to this harpy's song for the next 24 hours.

Unlike their more common kin, battle harpies are not against seeking combat to meet their desires as long as they can do so in groups. Lone battle harpies are still generally cowards.

The lead harpy of the cloud castle flock wears **gauntlets of hill giant strength** giving her 21 STR, +7 to hit, claw hit of 10 (2d6+5) slashing damage, and club hit of 7 (1d4+5) bludgeoning damage.

---

## Shadow Creeper

*Medium aberration, chaotic evil*

**Armor Class** 14

**Hit Points** 84 (12d8 + 30)

**Speed** 30 ft. (also see below)

STR	DEX	CON	INT	WIS	CHA
8 (-1)	15 (+2)	17 (+3)	11 (+0)	11 (+0)	8 (-1)

**Skills** Stealth +4 (+6 in dim light or darkness)

**Damage Resistances** cold, poison, thunder; bludgeoning, piercing, and slashing from nonmagical attacks

**Senses** darkvision 60 ft. passive Perception 12

**Languages** Deep Speech, telepathy 120 ft.

**Challenge** 4 (1,100 XP)

**Shadow Fragments.** The shadow creeper can create up to four shadow fragments. The creeper can cause these to appear in any shadow in visual range, preferring the shadow of a creature. A fragment has the same stats as a creeper, except it shares its hit points with the creeper and cannot create fragments itself.

**Follow Host.** When a shadow creeper or fragment is attached to the shadow of a creature, it can choose to move with that creature. This is a free-action by the creeper. Opponents do not gain opportunity attacks against the creeper when it moves this way.

### Actions

**Multiattack.** The shadow creeper and its fragments make two claw attacks.

**Claw.** *Melee Weapon Attack:* +7 to hit, reach 5 ft., one target. *Hit:* 6 (1d6 + 3) slashing damage plus 3 (1d6) cold damage. The creeper gains HP equal to half the damage inflicted by itself or a fragment, rounded-up, up to its HP maximum.

### Bonus Actions

**Create/Absorb Fragment.** The shadow creeper can create one or more shadow fragment or absorb existing ones.

Shadow creepers are things of unknown origin. On first sight they appear to be a kind of undead, but on closer inspection they act like elementals. They are neither (or maybe both). Regardless, they cannot be turned.

Creepers attach themselves to other creatures and “animate” their victims’ shadows to give themselves form. They can sustain themselves by slowly absorbing the life-force of their host, but are always seeking a more filling meal by attacking others.

---

### Elf Guards

*Medium humanoid (elf), chaotic neutral*

**Armor Class** 16 (breastplate)

**Hit Points** 9 (2d8)

**Speed** 30 ft.

STR	DEX	CON	INT	WIS	CHA
11 (+0)	14 (+2)	11 (+0)	13 (+1)	14 (+2)	16 (+3)

**Skills** Deception +5, Insight +4, Persuasion +5

**Senses** darkvision 60 ft., passive Perception 12

**Languages** Common, Elven, Giant

**Challenge** 1/8 (25 XP)

**Fey Ancestry.** An elf guard has advantage on saving throws against being charmed, and magic can't put the elf to sleep.

**Spellcasting.** An elf guard can cast the *minor illusion* cantrip at will. Spellcasting ability is Intelligence.

### Actions

**Rapier.** *Melee Weapon Attack:* +3 to hit, reach 5 ft., one target. *Hit:* 6 (1d8 + 1) piercing damage.

## NEW MAGIC ITEMS (Open Gaming Content)

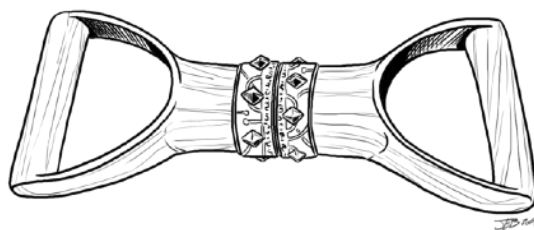

### Apparatus of Mutual Recall

*Wondrous item, rare*

This item is made of two dark-colored hardwood handles joined together by a pivoting metal band. Small, but expensive, gems are set on each side of the pivot.

When two creatures grab a handle and twist them in opposite directions, the creatures and the item will teleport to a target destination previously set, without error, if within the charging spell's movement range.

The item can only be used once and then must be charged by casting one of these spell upon it: *dimension door*, *teleport*, or *word of recall*. The target destination is set to where the charging occurred. If the item is already charged, the previous set destination is replaced.

Every time the item is used, there is a 5% cumulative chance it will teleport the users to an unexpected location in range. The chance resets to 5% after that happens.

### Cauldron of Ball Lightning

*Wondrous item, very rare*

This item appears to be a normal 3 ft. diameter cast iron cauldron used for cooking. When filled with water, mixed with 100 gp worth of herbs and the heart of an electric eel, and brought to a boil, the cauldron is activated and can be stirred to generate 10 inch diameter glowing bubbles. These bubbles can be mentally controlled by the creature that stirred the bubble into existence. These bubbles have multiple powers.

As a bonus action, the bubble's controller can move it 30 ft.

A bubble will explode when in the same space as another creature doing 18 (4d8) lightning damage (DC 13 Dexterity save for half).

When a bubble is within 5 ft. of its controller, they can use a reaction to block projectiles and magical attacks targeted against them, even a magic missile barrage. In addition, the controller has resistance to physical area affect attacks, as the bubble will negate part of the attack's energy. The bubble is destroyed in either case. Psychic and other non-physical attacks are not affected.

A bubble can be prematurely destroyed if it takes 6 HP damage — consider bubbles to be AC 10. The controller can also dismiss a bubble as a free-action.

Bubbles also provide faint light out to 30 ft. from their surface.

A creature can only control two bubbles at a time and cannot create more bubbles while controlling two bubbles. Although the cauldron does not require attunement, only three creatures can stir the contents of the cauldron per activation.

The cauldron is heavy and hard to tip over once filled, requiring a DC 16 Strength check. When empty, it can be rolled around on its side without much effort.

## Dancing Cutlery

*Weapon, uncommon*

This simple-looking knife has the word “**usugiri**” written on its blade. When the knife is placed over an object and the command word is spoken, it will begin dancing and try to dice the object. It does 2 (1d3) slashing damage to the target object, is +3 to hit regardless of the activator's proficiency, and is treated as non-magical for all other purposes.

When the target is completely diced, the knife will stop and hover for six seconds (1 turn) and then fall to the ground if not grabbed in that time period.

## OPEN GAME LICENSE

This printing of the “**Raiders of the Cloud Castle**” is done under version 1.0a of the Open Game License below.

**Notice of Open Game Content:** This product contains open game content as defined in the Open Game License below. Open game content may be used under and in the terms of the Open Game License.

**Designation of Open Game Content:** Any content within this book that is derived directly from the works under Section 15 of the Open Game License below is hereby designated as Open Game Content, subject to the Product Identity designation below. Also, any content explicitly listed as “Open Gaming Content” is released as Open Game Content.

**Designation of Product Identity:** The following items are hereby designated as Product Identity as provided in section 1(e) of the Open Game License:

1. The name “The Wyrmskeep Entertainment Co.” as well as the logos and identifying marks of The Wyrmskeep Entertainment Co., including but not limited to the Wyrmskeep logo as well as the trade dress of The Wyrmskeep Entertainment Co. products.

2. All artwork, cartography, depictions, designs, formats, graphic designs, likenesses, maps, poses, and symbols, including any text contained within such items.

3. The descriptions, motivations, names, and/or personalities, of all artifacts, characters, cities, city

states, countries, creatures, deities, enchantments, environments, equipment, feats, geographic features, gods, groups, historic events, items, locations, magical abilities, magical effects, monsters, organizations, places, planes, political features, races, skills, spells, supernatural abilities, and supernatural effects in this book as well as the name of any other thing not stemming from the works under Section 15 of the Open Game License below, but not their stat blocks or other game mechanic descriptions (if any).

4. All histories, plots, stories, storylines, and thematic elements.

5. Any other content previously designated as Product identity is hereby designated as Product Identity and is used with permission and/or pursuant to license.

6. Any and all content that is not otherwise Open Game Content by virtue of appearing as Open Game Content in a work listed in Section 15 of the Open Game License below.

## OPEN GAME LICENSE Version 1.0a

The following text is the property of Wizards of the Coast, Inc. and is Copyright 2000 Wizards of the Coast, Inc (“Wizards”). All Rights Reserved.

- 1 Definitions: (a)“Contributors” means the copyright and/or trademark owners who have contributed Open Game Content; (b)“Derivative Material” means copyrighted material including derivative works and translations (including into other computer languages), potation, modification, correction, addition, extension, upgrade,

improvement, compilation, abridgment or other form in which an existing work may be recast, transformed or adapted; (c) "Distribute" means to reproduce, license, rent, lease, sell, broadcast, publicly display, transmit or otherwise distribute; (d) "Open Game Content" means the game mechanic and includes the methods, procedures, processes and routines to the extent such content does not embody the Product Identity and is an enhancement over the prior art and any additional content clearly identified as Open Game Content by the Contributor, and means any work covered by this License, including translations and derivative works under copyright law, but specifically excludes Product Identity. (e) "Product Identity" means product and product line names, logos and identifying marks including trade dress; artifacts; creatures characters; stories, storylines, plots, thematic elements, dialogue, incidents, language, artwork, symbols, designs, depictions, likenesses, formats, poses, concepts, themes and graphic, photographic and other visual or audio representations; names and descriptions of characters, spells, enchantments, personalities, teams, personas, likenesses and special abilities; places, locations, environments, creatures, equipment, magical or supernatural abilities or effects, logos, symbols, or graphic designs; and any other trademark or registered trademark clearly identified as Product identity by the owner of the Product Identity, and which specifically excludes the Open Game Content; (f) "Trademark" means the logos, names, mark, sign, motto, designs that are used by a Contributor to identify itself or its products or the associated products contributed to the Open Game License by the Contributor (g) "Use", "Used" or "Using" means to use, Distribute, copy, edit, format, modify, translate and otherwise create Derivative Material of Open Game Content. (h) "You" or "Your" means the licensee in terms of this agreement.

2 The License: This License applies to any Open Game Content that contains a notice indicating that the Open Game Content may only be Used under and in terms of this License. You must affix such a notice to any Open Game Content that you Use. No terms may be added to or subtracted from this License except as described by the License itself. No other terms or conditions may be applied to any Open Game Content distributed using this License.

3 Offer and Acceptance: By Using the Open Game Content You indicate Your acceptance of the terms of this License.

4 Grant and Consideration: In consideration for agreeing to use this License, the Contributors grant You a perpetual, worldwide, royalty-free, non-exclusive license with the exact terms of this License to Use, the Open Game Content.

5 Representation of Authority to Contribute: If You are contributing original material as Open Game Content, You represent that Your Contributions are Your original creation and/or You have sufficient rights to grant the rights conveyed by this License.

6 Notice of License Copyright: You must update the COPYRIGHT NOTICE portion of this License to include the exact text of the COPYRIGHT NOTICE of any Open Game Content You are copying, modifying or distributing, and You must add the title, the copyright date, and the copyright holder's name to the COPYRIGHT NOTICE of any original Open Game Content you Distribute.

7 Use of Product Identity: You agree not to Use any Product Identity, including as an indication as to compatibility, except as expressly licensed in another, independent Agreement with the owner of each element of that Product Identity. You agree not to indicate compatibility or co-adaptability with any Trademark or Registered Trademark in conjunction with a work containing Open Game Content except as expressly licensed in another, independent Agreement with the owner of such Trademark or Registered Trademark. The use of any Product Identity in Open Game Content does not constitute a challenge to the ownership of that Product Identity. The owner of any Product Identity used in Open Game Content shall retain all rights, title and interest in and to that Product Identity.

8 Identification: If you distribute Open Game Content You must clearly indicate which portions of the work that you are distributing are Open Game Content.

9 Updating the License: Wizards or its designated Agents may publish updated versions of this License. You may use any authorized version of this License to copy, modify and distribute any Open Game Content originally distributed under any version of this License.

10 Copy of this License: You MUST include a copy of this License with every copy of the Open Game Content You Distribute.

11 Use of Contributor Credits: You may not market or advertise the Open Game Content using the name of any Contributor unless You have written permission from the Contributor to do so.

12 Inability to Comply: If it is impossible for You to comply with any of the terms of this License with respect to some or all of the Open Game Content due to statute, judicial order, or governmental regulation then You may not Use any Open Game Material so affected.

13 Termination: This License will terminate automatically if You fail to comply with all terms herein and fail to cure such breach within 30 days of becoming aware of the breach. All sublicenses shall survive the termination of this License.

14 Reformation: If any provision of this License is held to be unenforceable, such provision shall be reformed only to the extent necessary to make it enforceable.

15 COPYRIGHT NOTICE Open Game License v 1.0a Copyright 2000, Wizards of the Coast, LLC. System Reference Document 5.1 Copyright 2016, Wizards of the Coast, Inc.; Authors Mike Mearls, Jeremy Crawford, Chris Perkins, Rodney Thompson, Peter Lee, James Wyatt, Robert J. Schwab, Bruce R. Cordell, Chris Sims, and Steve Townshend, based on original material by E. Gary Gygax and Dave Arneson.

5thsrd.org, copyright 2016, vitusventure.



# SECOND TOWER

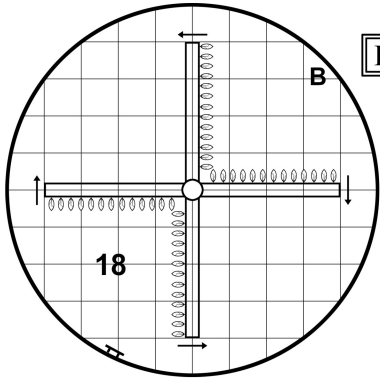

FLOOR 1

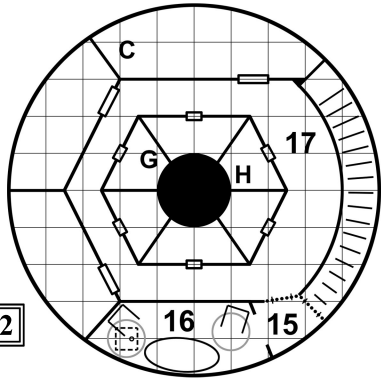

FLOOR 2

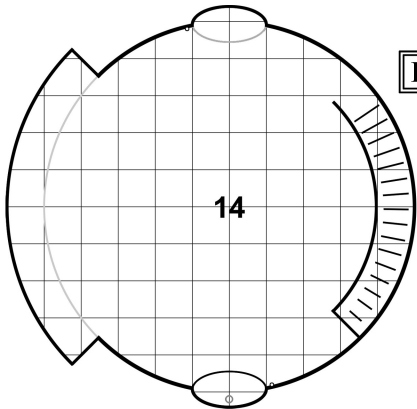

FLOOR 3

□ 10'x10'

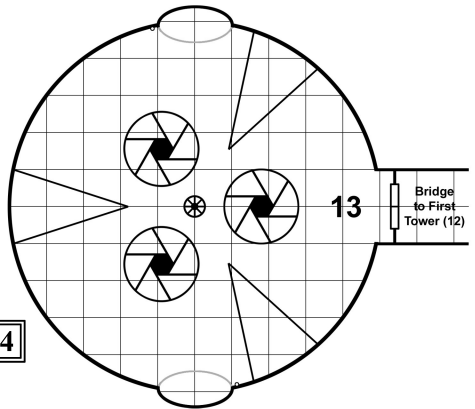

FLOOR 4

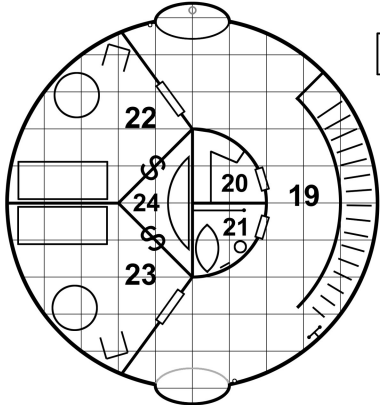

FLOOR 5

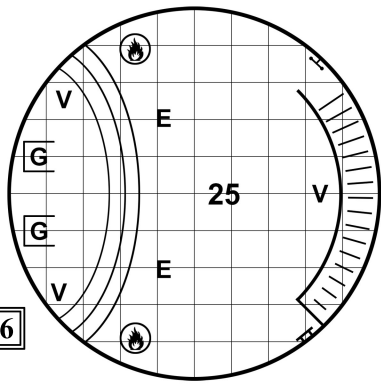

FLOOR 6

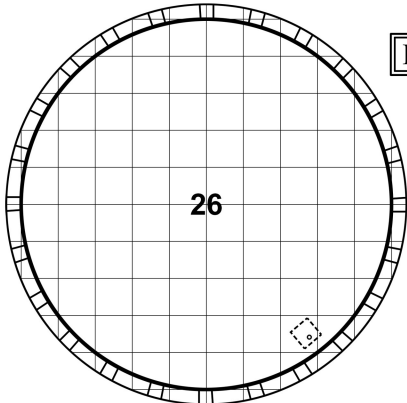

ROOF

**LEGEND**

	Medium Door		Furniture
	Huge Door		Crank Wheel Vertical & Horizontal
	Huge Double Door		Ladder
	Secret Door		Trapdoor
	Stairs		Lift Here
	Metal Gate		Lift Not Here

## Pre-Generated Player Characters

This document is a supplement to **Wyrmskeep Dungeons TZ1: Raiders of the Cloud Castle** and provides ready-to-run characters for your players to use in the situation that they do not have characters of the appropriate level for the adventure.

Page 2: Aerzoth RedLeaf • Male Half-Elf Level 9 Wizard (School of Evocation)

Page 3: Justinia "Sergeant" Boc • Female Human Level 9 Fighter (Champion)

Page 4: Halfir Steadhearth • Male Hill Dwarf Level 9 Fighter (Champion)

Page 5: Lio Talaiil • Male High Elf Level 9 Bard (College of Lore)

Page 6: Flint Ungarian • Male Rock Gnome Level 9 Ranger (Hunter)

Page 7: Zhur Ykka • Female Blue Dragonborn Level 9 Monk (Way of the Open Hand)

Page 8: Florda Merrybrook • Female Lightfoot Halfling Level 9 Cleric (Life Domain)

Page 9: Racyr Bastardblade • Male Human Level 9 Rogue (Assassin)

The players can change the character names, genders, and alignments in consultation with the GM.

The cleric and wizard should choose their prepared spells before the adventure begins. Given the limited time the party has to thwart the raiders, no opportunity will arise to change spells.

As GM you are welcome to allow the players to buy additional mundane (non-magical) equipment from their funds. Unless specifically stated in the module, gems acquired are whatever kind is most convenient to the party.

Magic items are indicated by *italic text*.

If the party is composed of all eight pre-generated characters, the total levels are slightly above the suggested level range. There should be no need to adjust the strength of the opponents to compensate.

Finally, the last page of this supplement has optional backgrounds for each character. Use as you see fit!



## Aerzoth RedLeaf • Male Half-Elf Level 9 Wizard (School of Evocation)

**Player:** \_\_\_\_\_

**Alignment:** Chaotic good

**Strength:** 10 (+0)  
**Dexterity:** 13 (+1)  
**Constitution:** 14 (+2)  
**Intelligence:** 18 (+4)  
**Wisdom:** 12 (+1)  
**Charisma:** 14 (+2)

**Armor Class:** 12  
**Initiative:** +1  
**Speed:** 30  
**Hit Points:** 56  
**Hit Dice:** 9d6+18  
**Experience Points:** 48,000

**Proficiency Bonus:** +4  
**Passive Perception:** 11

### *Saving Throws*

**Strength:** +1  
**Dexterity:** +2  
**Constitution:** +3  
**Intelligence:** +9 •  
**Wisdom:** +6 •  
**Charisma:** +3

**Skills**  
**Acrobatics:** +1  
**Animal Handling:** +5 •  
**Arcana:** +8 •  
**Athletics:** +0  
**Deception:** +2  
**History:** +4  
**Insight:** +5 •  
**Intimidation:** +2  
**Investigation:** +8 •  
**Medicine:** +1  
**Nature:** +4  
**Perception:** +1  
**Performance:** +6 •  
**Persuasion:** +6 •  
**Religion:** +4  
**Sleight of Hand:** +1  
**Stealth:** +1  
**Survival:** +5 •

• Proficient skills

### *Languages*

Common  
 Draconic  
 Elvish  
 Sylvan

### *Other Skills*

Alchemist Supplies  
 Land Vehicles

<b>Attacks</b>	<b>Bonus</b>	<b>Damage</b>
+1 <i>Dagger</i>	+6	1d4+2 piercing
Sling	+5	1d4+1 bludgeon

### *Features & Traits*

Arcane Recovery  
 Darkvision  
 Evocation Savant  
 Fey Ancestry  
 Potent Cantrip  
 Sculpt Spells

### *Items*

Pouch w/145 gp, 100 gp gem (2)  
 Black Ink, Quill & Parchment (10 sheets)  
 Backpack  
 Signet ring  
 Bag of Sand  
 Clothes, fine  
 Explorer's Pack  
 Arcane Focus  
 Spellbook  
 Alchemist Supplies  
*Potion of Healing (2)*  
*Oil of Slipperiness*  
*Wand of Magic Detection*  
*Ring of Protection*

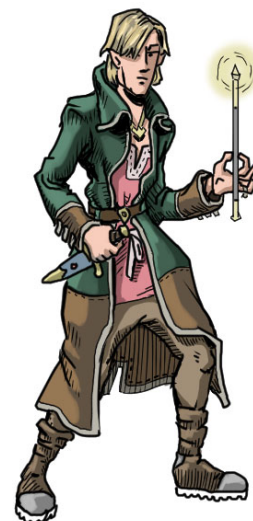

**Spells (Known)**

**Ability:** Intelligence

**Spell DC:** 16

**Attack Bonus:** +8

### **Cantrips**

Acid Splash  
 Mage Hand  
 Message  
 True Strike

### **2nd Level [3]**

Arcane Lock  
 Gust of Wind  
 Knock  
 Mirror Image  
 Scorching Ray

### **4th Level [3]**

Conjure Minor Elementals  
 Dimension Door  
 Otil.'s Resilient Sphere  
 Wall of Fire

### **1st Level [4]**

Comprehend Languages  
 Feather Fall  
 Fog Cloud  
 Identify  
 Mage Armor  
 Magic Missile

### **3rd Level [3]**

Dispel Magic  
 Fly  
 Haste  
 Lightning Bolt  
 Stinking Cloud

### **5th Level [1]**

Cone of Cold  
 Hold Monster

Aerzoth should prepare 13 spells from the above lists.

## Justinia "Sergeant" Boc • Female Human Level 9 Fighter (Champion)

**Player:** \_\_\_\_\_

**Alignment:** Neutral good

**Strength:** 14 (+2)  
**Dexterity:** 19 (+4)  
**Constitution:** 16 (+3)  
**Intelligence:** 11 (+0)  
**Wisdom:** 12 (+1)  
**Charisma:** 12 (+1)

**Armor Class:** 17  
**Initiative:** +6  
**Speed:** 30  
**Hit Points:** 85  
**Hit Dice:** 9d10+27  
**Experience Points:** 48,000

**Proficiency Bonus:** +4  
**Passive Perception:** 11

### **Saving Throws**

**Strength:** +6 •  
**Dexterity:** +4  
**Constitution:** +7 •  
**Intelligence:** +0  
**Wisdom:** +1  
**Charisma:** +1

**Skills**

<b>Acrobatics:</b>	+6
<b>Animal Handling:</b>	+1
<b>Arcana:</b>	+0
<b>Athletics:</b>	+6 •
<b>Deception:</b>	+1
<b>History:</b>	+0
<b>Insight:</b>	+5 •
<b>Intimidation:</b>	+5 •
<b>Investigation:</b>	+0
<b>Medicine:</b>	+1
<b>Nature:</b>	+0
<b>Perception:</b>	+1
<b>Performance:</b>	+1
<b>Persuasion:</b>	+1
<b>Religion:</b>	+0
<b>Sleight of Hand:</b>	+6
<b>Stealth:</b>	+6
<b>Survival:</b>	+5 •

• Proficient skills

### **Languages**

Common  
 Orc

### **Other Skills**

Dice Set  
 Land Vehicles

<b>Attacks</b>	<b>Bonus</b>	<b>Damage</b>
Greatsword	+6	2d6+2 slashing
+2 Handaxe	+8	1d6+4 slashing
+1 Longbow	+11	1d8+5 piercing

### **Features & Traits**

Action Surge  
 Archery Fighting Style  
 Extra Attack (2 total)  
 Improved Critical  
 Indomitable  
 Remarkable Athlete  
 Second Wind

### **Items**

Pouch w/150 gp  
 +1 Studded leather  
 Arrow (20)  
 Backpack  
 Waterskin  
 Bedroll  
 Rations (1 day) (10)  
 Rope, hempen  
 Tinderbox  
 Mess kit  
 Torch (10)  
 Dice Set  
 Potion of healing (2)  
 Potion of water breathing  
 Lantern of revealing



## Halfir Steadhearth • Male Hill Dwarf Level 9 Fighter (Champion)

Player: \_\_\_\_\_

Alignment: Lawful good

**Strength:** 18 (+4)  
**Dexterity:** 14 (+2)  
**Constitution:** 14 (+2)  
**Intelligence:** 13 (+1)  
**Wisdom:** 11 (+0)  
**Charisma:** 12 (+1)

**Armor Class:** 20  
**Initiative:** +4  
**Speed:** 25  
**Hit Points:** 85  
**Hit Dice:** 9d10+18  
**Experience Points:** 48,000

**Proficiency Bonus:** +4  
**Passive Perception:** 10

### *Saving Throws*

**Strength:** +8 •  
**Dexterity:** +2  
**Constitution:** +6 •  
**Intelligence:** +1  
**Wisdom:** +0  
**Charisma:** +1

**Skills**  
**Acrobatics:** +4  
**Animal Handling:** +0  
**Arcana:** +1  
**Athletics:** +8 •  
**Deception:** +1  
**History:** +5 •  
**Insight:** +4 •  
**Intimidation:** +1  
**Investigation:** +1  
**Medicine:** +0  
**Nature:** +1  
**Perception:** +0  
**Performance:** +1  
**Persuasion:** +1  
**Religion:** +5 •  
**Sleight of Hand:** +4  
**Stealth:** +4  
**Survival:** +0

• Proficient skills

### *Languages*

Common  
Dwarvish  
Giant  
Goblin

### *Other Skills*

Brewer's Supplies

<b>Attacks</b>	<b>Bonus</b>	<b>Damage</b>
+1 Battleaxe	+9	1d8+5 slashing
Lt. Crossbow	+6	1d8+2 piercing

### *Features & Traits*

Action Surge  
Defense Fighting Style  
Dwarven Resilience  
Darkvision  
Extra Attack (2 total)  
Improved Critical  
Indomitable  
Remarkable Athlete  
Second Wind  
Shelter the Faithful  
Stonecunning

### *Items*

Pouch w/205 gp  
+1 Shield  
Chain mail  
Crossbow bolt (20)  
Clothes, common  
Backpack  
Piton (10)  
Waterskin  
Brewer's Supplies  
Incense  
Rations (1 day) (10)  
Rope, hempen  
Vestments  
Prayer Book  
Tinderbox  
Hammer  
Crowbar  
Torch (10)  
Emblem  
Potion of healing (2)  
Potion of growth  
Bag of holding



Lio Talaiil · Male High Elf Level 9 Bard (College of Lore)

Player: \_\_\_\_\_

Alignment: Chaotic good

**Strength:** 12 (+1)  
**Dexterity:** 17 (+3)  
**Constitution:** 12 (+1)  
**Intelligence:** 13 (+1)  
**Wisdom:** 11 (+0)  
**Charisma:** 15 (+2)

**Armor Class:** 16  
**Initiative:** +5  
**Speed:** 30  
**Hit Points:** 57  
**Hit Dice:** 9d8+9  
**Experience Points:** 48,000

**Proficiency Bonus:** +4  
**Passive Perception:** 14

**Saving Throws**

**Strength:** +1  
**Dexterity:** +7 •  
**Constitution:** +1  
**Intelligence:** +1  
**Wisdom:** +0  
**Charisma:** +6 •

**Skills**  
**Acrobatics:** +7 •  
**Animal Handling:** +2  
**Arcana:** +5 •  
**Athletics:** +3  
**Deception:** +6 •  
**History:** +3  
**Insight:** +8 •  
**Intimidation:** +4  
**Investigation:** +5 •  
**Medicine:** +4 •  
**Nature:** +3  
**Perception:** +4 •  
**Performance:** +10 •  
**Persuasion:** +6 •  
**Religion:** +3  
**Sleight of Hand:** +5  
**Stealth:** +5  
**Survival:** +2 •

• Proficient skills

**Languages**

Common  
 Elvish  
 Orc  
 Sylvan

**Other Skills**

Flute, Horn, Lute  
 Tinker's Tools

<b>Attacks</b>	<b>Bonus</b>	<b>Damage</b>
+1 Longsword	+6	1d8+2 slashing
+2 Dagger	+9	1d4+5 piercing
Dagger	+7	1d4+3 piercing

**Features & Traits**

Bardic Inspiration  
 Countercharm  
 Cutting Words  
 Darkvision  
 Fey Ancestry  
 Font of Inspiration  
 Jack of All Trades (already applied to skills)  
 Song of Rest  
 Trance

**Items**

Pouch w/185 gp  
 +2 Leather armor  
 Clothes, traveler's  
 Backpack  
 Waterskin  
 Candle (5)  
 Disguise Kit  
 Bedroll  
 Rations (1 day) (5)  
 Costume  
 Tinker's Tools  
 Lute  
 Potion of healing (2)  
 Potion of invulnerability  
 Cloak of elvenkind



**Spells**

**Ability:** Charisma

**Spell DC:** 14

**Attack Bonus:** +6

**Cantrips**

Fire Bolt (racial, INT, DC 13, AB +5)  
 Minor Illusion  
 True Strike  
 Vicious Mockery

**2nd Level [3]**

Calm Emotions  
 Invisibility  
 See Invisibility

**4th Level [3]**

Dimension Door  
 Freedom of Movement

**1st Level [4]**

Charm Person  
 Feather Fall  
 Healing Word  
 Magic Missile  
 T.'s Hideous Laughte

**3rd Level [3]**

Dispel Magic Haste  
 Hypnotic Pattern

**5th Level [1]**

Greater Restoration

## Flint Ungarian • Male Rock Gnome Level 9 Ranger (Hunter)

**Player:** \_\_\_\_\_

**Alignment:** Neutral good

**Strength:** 14 (+2)  
**Dexterity:** 16 (+3)  
**Constitution:** 12 (+1)  
**Intelligence:** 12 (+1)  
**Wisdom:** 14 (+2)  
**Charisma:** 12 (+1)

**Armor Class:** 16  
**Initiative:** +4  
**Speed:** 25  
**Hit Points:** 67  
**Hit Dice:** 9d10+9  
**Experience Points:** 48,000

**Proficiency Bonus:** +4  
**Passive Perception:** 16

**Saving Throws**

**Strength:** +6 •  
**Dexterity:** +7 •  
**Constitution:** +1  
**Intelligence:** +1  
**Wisdom:** +2  
**Charisma:** +1

**Skills**  
**Acrobatics:** +3  
**Animal Handling:** +6 •  
**Arcana:** +1  
**Athletics:** +6 •  
**Deception:** +1  
**History:** +1  
**Insight:** +2  
**Intimidation:** +1  
**Investigation:** +1  
**Medicine:** +2  
**Nature:** +5 •  
**Perception:** +6 •  
**Performance:** +1  
**Persuasion:** +1  
**Religion:** +1  
**Sleight of Hand:** +3  
**Stealth:** +3  
**Survival:** +6 •

• Proficient skills

**Languages**

Common  
 Elvish  
 Giant  
 Gnomish  
 Goblin

**Other Skills**

Pan Flute  
 Tinker's Tools

<b>Attacks</b>	<b>Bonus</b>	<b>Damage</b>
+2 <i>Swortsword</i>	+9	1d6+5 piercing
Swortsword	+7	1d6+3 piercing
Longbow	+7	1d8+3 piercing

**Features & Traits**

Artificer's Lore  
 Darkvision  
 Escape the Horde  
 Favored Enemy (goblin, bugbear)  
 Giant Killer  
 Gnome Cunning  
 Land's Stride  
 Natural Explorer (mountain, forest)  
 Primeval Awareness  
 Tinker  
 Two-Weapon Fighter

**Items**

Pouch w/105 gp  
 +1 *Studded armor*  
 Arrow (20)  
 Quiver  
 Backpack  
 Waterskin  
 Bedroll  
 Rations (1 day) (10)  
 Rope, hempen  
 Tinderbox  
 Clothes, traveler's  
 Mess kit  
 Pan Flute  
 Tinker's Tools  
 Torch (10)  
*Potion of healing (2)*  
*Potion of climbing*  
*Circlet of blasting*



**Spells**

**Ability:** Wisdom

**Spell DC:** 14

**Attack Bonus:** +6

**1st Level [4]**

Alarm  
 Cure Wounds  
 Speak with Animals

**2nd Level [3]**

Lesser Restoration  
 Spike Growth

**3rd Level [2]**

Protection from Energy

## Zhur Ykka • Female Blue Dragonborn Level 9 Monk (Way of the Open Hand)

**Player:** \_\_\_\_\_

**Alignment:** Lawful neutral

**Strength:** 14 (+2)  
**Dexterity:** 18 (+4)  
**Constitution:** 14 (+2)  
**Intelligence:** 10 (+0)  
**Wisdom:** 12 (+1)  
**Charisma:** 11 (+0)

**Armor Class:** 16  
**Initiative:** +4  
**Speed:** 45/30  
**Hit Points:** 66  
**Hit Dice:** 9d8+18  
**Experience Points:** 48,000

**Proficiency Bonus:** +4  
**Passive Perception:** 11

### *Saving Throws*

**Strength:** +7 •  
**Dexterity:** +9 •  
**Constitution:** +3  
**Intelligence:** +1  
**Wisdom:** +2  
**Charisma:** +1

**Skills**  
**Acrobatics:** +8 •  
**Animal Handling:** +1  
**Arcana:** +0  
**Athletics:** +2  
**Deception:** +0  
**History:** +0  
**Insight:** +1  
**Intimidation:** +0  
**Investigation:** +0  
**Medicine:** +5 •  
**Nature:** +0  
**Perception:** +1  
**Performance:** +0  
**Persuasion:** +0  
**Religion:** +4 •  
**Sleight of Hand:** +4  
**Stealth:** +8 •  
**Survival:** +1

• Proficient skills

### *Languages*

Common  
 Deep Speech  
 Draconic

### *Other Skills*

Healer's Kit  
 Herbalism Kit

<b>Attacks</b>	<b>Bonus</b>	<b>Damage</b>
Unarmed strike	+8	1d6+4 bludgeon
Shortsword	+8	1d6+4 piercing
+2 Dart (3)	+10	1d4+6 piercing
Dart	+8	1d4+4 bludgeon

Breath Weapon. Lightning, 5 x 30 ft. line, 3d6 lightning damage, DC14 DEX save.

### *Features & Traits*

Damage Resistances: lightning  
 Deflect Missiles  
 Evasion  
 Ki (9)  
 Ki-Empowered Strikes  
 Open Hand Technique  
 Slow Fall  
 Flurry of Blows  
 Martial Arts  
 Patient Defense  
 Step of the Wind  
 Stillness of Mind  
 Stunning Strike  
 Wholeness of Body

### *Items*

Pouch w/65 gp  
 Backpack  
 Clothes, common  
 Piton (10)  
 Abacus  
 Waterskin  
 Rations (1 day) (10)  
 Rope, hempen  
 Tinderbox  
 Hammer  
 Blanket  
 Backpack  
 Crowbar  
 Healer's Kit  
 Herbalism Kit  
 Torch (10)  
*Potion of healing (2)*  
*Ring of protection*  
*Alchemy jug*



## Florida Merrybrook • Female Lightfoot Halfling Level 9 Cleric (Life Domain)

**Player:** \_\_\_\_\_

**Alignment:** Lawful neutral

**Strength:** 10 (+0)  
**Dexterity:** 12 (+1)  
**Constitution:** 14 (+2)  
**Intelligence:** 12 (+1)  
**Wisdom:** 18 (+4)  
**Charisma:** 14 (+2)

**Armor Class:** 18  
**Initiative:** +1  
**Speed:** 25  
**Hit Points:** 66  
**Hit Dice:** 9d8+18  
**Experience Points:** 48,000

**Proficiency Bonus:** +4  
**Passive Perception:** 14

### *Saving Throws*

**Strength:** +0  
**Dexterity:** +1  
**Constitution:** +2  
**Intelligence:** +1  
**Wisdom:** +8 •  
**Charisma:** +6 •

**Skills**  
**Acrobatics:** +1  
**Animal Handling:** +4  
**Arcana:** +1  
**Athletics:** +0  
**Deception:** +2  
**History:** +1  
**Insight:** +4  
**Intimidation:** +2  
**Investigation:** +1  
**Medicine:** +8 •  
**Nature:** +1  
**Perception:** +4  
**Performance:** +2  
**Persuasion:** +2  
**Religion:** +5 •  
**Sleight of Hand:** +5 •  
**Stealth:** +5 •  
**Survival:** +4

• Proficient skills

### *Languages*

Common  
 Halfling

### *Other Skills*

Disguise Kit  
 Thieves' Tools

<b>Attacks</b>	<b>Bonus</b>	<b>Damage</b>
Mace of Smiting	+5	1d6+1 bludgeon
Dagger	+5	1d4+1 piercing

### *Features & Traits*

Blessed Healer  
 Brave  
 Channel Divinity: Preserve Life, Turn Undead, Destroy Undead (CR 1)  
 Disciple of Life  
 Divine Strike  
 Halfling Nimbleness  
 Lucky  
 Naturally Stealthy

### *Items*

Pouch w/160 gp  
 Scale mail  
*+1 Shield*  
 Backpack  
 Clothes, common  
 Disguise Kit  
 Thieves' Tools  
 Waterskin  
 Candle  
 Alms Box  
 Incense (2)  
 Rations (1 day) (2)  
 Censer  
 Amulet  
 Vestments  
 Tinderbox  
 Blanket  
*Potion of healing (3)*  
*Potion of clairvoyance*  
*Driftglobe*



### *Spells*

**Ability:** Wisdom

**Spell DC:** 16

**Attack Bonus:** +8

### **Cantrips**

Purify Food and Drink  
 Sanctuary  
 Shield of Faith

### **2nd Level [3]**

Lesser Restoration (Domain)  
 Spiritual Weapon (Domain)

### **4th Level [3]**

Death Ward (Domain)  
 Guardian of Faith (Domain)

### **1st Level [4]**

Bless (Domain)  
 Cure Wounds (Domain)

### **3rd Level [3]**

Beacon of Hope (Domain)  
 Revivify (Domain)

### **5th Level [1]**

Mass Cure Wounds (Domain)  
 Raise Dead (Domain)

Florida should prepare 13 spells from Cleric spell list (1st to 5th level) to add to her known Domain spells.

Racyr Bastardblade • Male Human Level 9 Rogue (Assassin)

Player: \_\_\_\_\_

Alignment: Neutral

**Strength:** 11 (+0)  
**Dexterity:** 18 (+4)  
**Constitution:** 14 (+2)  
**Intelligence:** 13 (+1)  
**Wisdom:** 11 (+0)  
**Charisma:** 16 (+3)

**Armor Class:** 17  
**Initiative:** +4  
**Speed:** 30  
**Hit Points:** 66  
**Hit Dice:** 9d8+18  
**Experience Points:** 48,000

**Proficiency Bonus:** +4  
**Passive Perception:** 10

**Saving Throws**

**Strength:** +0  
**Dexterity:** +8 •  
**Constitution:** +2  
**Intelligence:** +5 •  
**Wisdom:** +3  
**Charisma:** +3

**Skills**  
**Acrobatics:** +8 •  
**Animal Handling:** +0  
**Arcana:** +1  
**Athletics:** +0  
**Deception:** +11 •  
**History:** +1  
**Insight:** +4 •  
**Intimidation:** +3  
**Investigation:** +1  
**Medicine:** +0  
**Nature:** +1  
**Perception:** +0  
**Performance:** +3  
**Persuasion:** +7 •  
**Religion:** +1  
**Sleight of Hand:** +12 •  
**Stealth:** +12 •  
**Survival:** +0

• Proficient skills

**Languages**

Common  
 Elvish

**Other Skills**

Thieves Tools  
 Disguise Kit  
 Forgery Kit  
 Poisoners Kit

**Attacks**      **Bonus**      **Damage**  
*+1 Rapier*      +9      1d8+5 piercing  
 Shortbow      +8      1d6+4 piercing  
 Dagger      +8      1d6+4 piercing

**Features & Traits**

Assassinate  
 Cunning Action  
 Evasion  
 Sneak Attack  
 Thieves' Cant  
 Uncanny Dodge

**Items**

Pouch w/189 gp  
*+2 Leather armor*  
 Quiver  
 Arrow (20)  
 Acid  
 Piton (10)  
 Waterskin  
 Signet ring  
 Candle (5)  
 Lantern, hooded  
 Oil (2)  
 Thieves Tools  
 Disguise Kit  
 Forgery Kit  
 Poisoners Kit  
 Rations (1 day) (5)  
 Poison, basic  
 Rope, hempen  
 String  
 Tinderbox  
 Hammer  
 Bell  
 Backpack  
 Clothes, fine  
 Ball bearings  
 Crowbar  
*Potion of healing (2)*  
*Dust of disappearance*  
*Immovable rod*





## Character Backgrounds

### **Aerzoth RedLeaf**

Aerzoth RedLeaf gained his fame from leading a group of villagers against a juvenile black dragon that was terrorizing the surrounding area. He does not match the usual stereotype of the self-absorbed and uncaring wizard.

### **Justinia "Sergeant" Boc**

Justinia Boc served in the army of the Great Empire faithfully until a corrupt superior tried to order her squad to destroy a village for his personal gain. She was able to expose his treachery, but (unjustified) distrust in her by other powerful officers led to the "Sergeant" choosing to resign. After that she fell into the life of an adventurer.

### **Halfir Steadhearth**

Halfir Steadhearth was trained to follow in the family tradition of religious service by his father. Unfortunately, Halfir didn't really have the understanding of the subtleties of spell-casting. The young dwarf decided to take a more physical route to smiting evil by becoming a warrior.

### **Lio Talaiil**

Lio Talaiil discovered the magic of stories to entertain and enlighten others very early. But when he learned that there was also real magic in song, Lio knew he had found his destiny. Being a thrill seeker, he gravitated to joining other explorers as to seek out lost legends and forgotten melodies of power.

### **Flint Ungarian**

Flint Ungarian comes from a long line of rangers that protected the gnomish lands in which he grew up. Although he has followed in that line of work, he became interested in learning more about the outside world. Flint has foregone his home for now, but never forgets his purpose: to protect the weak from the degradations of uncivilized monsters.

### **Zhur Ykka**

Zhur Ykka was shunned as a cross-breed child and found comfort in punching-out others as part of a fighting club in her home town. At some point Zhur was mentored by a half-orc monk that recognized her talent and guessed that she would appreciate the art, power, and personal reliance that comes from the martial arts. She now travels about seeking to knock some sense into the world.

### **Florda Merrybrook**

The young Florda Merrybrook fell under the sway of a nefarious halfling rogue. One day she (badly) failed to pick the pocket of a human; but instead of being angry, the man sought to bring Florda out of the dark and into the light of righteousness. Originally thinking she would just follow along as a ruse, she instead found real meaning in faith. There is still a bit of a thief in her though, but now it's used to "steal" other souls to the cause.

### **Racyr Bastardblade**

If you ask anyone to describe Racyr Bastardblade, the most likely response would be, "He is one handsome, smooth talking gentleman." As a famed raconteur, he is regularly invited to social gatherings. Just the places to glean knowledge about those who may have "disposable items" for Racyr to acquire. Although he is a semi-retired adventurer, Racyr couldn't miss the chance to explore a legendary dungeon, even if he did have to leave his current home in Barrowash (see *Wyrmskeep Dungeons BW3: The Beast Below*).

This module is designed for 5-8 characters of level 8-10, approximately 50-65 levels total. The party should consist of at least two fighters, one cleric, one mage, and one rogue (or equivalent classes). Any characters who routinely engage in melee or ranged weapon combat should have access to magic weapons or projectiles.



This module is 5th Edition System Reference Document (SRD) compatible. The SRD can be found on multiple sites on the web — search for “5th Edition SRD” with your favorite browser. You can play this adventure with any fantasy role-playing system you may want under the Open Game License v1.0a and is easily adapted to most campaign settings.

Other fine products from The Wyrmskeep Entertainment Co.

#### **Fantasy Role-playing Modules**

- Wyrmskeep Dungeons BW1: Temple of the Dragon Kin
- Wyrmskeep Dungeons BW2: Befouled Maze of the Demi-Lich
- Wyrmskeep Dungeons BW3: The Beast Below
- Wyrmskeep Dungeons TZ2: Curse of the Desert Outpost (coming soon)

#### **Superhero Role-playing Module**

- Heroic Havoc #1: Instant Circus Is Going to Get You!

#### **Computer Adventure Games**

- Inherit the Earth: Quest for the Orb
- The Labyrinth of Time



[wyrmskeep.com/rpg](http://wyrmskeep.com/rpg)