

# A GOING CONCERN

Optional Rules for Owning and Operating a  
Business in 5<sup>th</sup> Edition Dungeons & Dragons



## Credits

### Design:

P. Daniel Johnson

### Artwork Courtesy Of:

Rijksmuseum

Pixabay

Thanks to Christopher Dyer, whose excellent book *Making a Living in the Middle Ages* was an invaluable reference and inspiration for this supplement.

A Going Concern, copyright © 2017 Paul Daniel Johnson, all rights reserved

## Foreword

I was browsing through the mods for Skyrim a while back. (Most readers will know Skyrim as a video game that was quite popular a few years ago). What struck me about these mods is that the most common sort were all about creating new homes for the player. If you've seen any promotional media for Skyrim, you'll know it's about running around dangerous adventure sites fighting with dragons and zombies and so forth. None of the promotional material focuses on anyone sitting around at home. Yet the most popular and common mods are about exactly that.

It got me thinking about the need players have to feel as though they're a part of the world they're playing in. For many, and I count myself among this number, it isn't enough to materialise in the game to slay and loot for a while before disappearing again when it's time for dinner. I think that's part of the attraction inherent in player character-owned businesses. There's another part, too, which is that the accomplishment of building up a successful business can be every bit as satisfying for many players as leveling up a character and completing heroic quests.

Being an accountant, it felt natural for me to try to leverage my work experiences to create something that expands on the downtime rules for running a business present in the *Dungeon Master's Guide*. The trick was to construct an optional ruleset that provides for a more immersive experience of owning a business but at the same time still feels fun and not like a bookkeeping chore.

Hopefully what you find on the pages within doesn't miss that goal by too much.

P. Daniel Johnson, Summer 2017

# Contents

---

- Introduction ..... 1
- Overview ..... 3
- Starting a Business..... 4
  - Types of Businesses ..... 4
  - Investment..... 7
    - Shared investments..... 8
    - Business Combinations ..... 8
  - Buying a Business..... 9
  - Starting From Scratch ..... 9
- Business Culture..... 10
  - Changing Culture ..... 12
- The Risk Factor ..... 12
- Operating a Business .....13
  - The Monthly Business Cycle.....13
  - Market Environment ..... 14
    - Developing a Narrative for Market Conditions..... 15
  - Random Events ..... 16
  - Management Actions..... 18
  - Interest ..... 22
- Return on Investment ..... 24
  - Monthly Performance ..... 25
    - Profit and Loss Considerations for Shared Investments and Business Combinations ..... 27
- New Background – Family Business ..... 28
- Feudal and Capitalist Economies..... 29
- Magic..... 30
- Adventure Hooks .....31
- Business Examples..... 32
  - Business Example 1: The Emblazoned Escutcheon ..... 32
  - Business Example 2: The Orc’s Fork Tavern and Flophouse .....33
- The Business Sheet .....37
- Legal..... 38

## Introduction

---

*The workshop smelled of sawdust and machine oil. Kiln traced the parallel paths left by the legs of the table he now hunched over through the wood shavings that littered the floor from where he had dragged it across the room. It wasn't a large workshop. During the day this space was filled with craftsmen and labourers, but at night it made for a decent meeting space, even if the furniture needed to be rearranged for it. The tabletop was the only visible surface not piled with tools and half-finished bits of carpentry.*

*Across the table, the half-elf was studying a parchment roll she held open with spread fingers. He couldn't read anything on it from where he sat. There was some sort of diagram surrounded by incomprehensible scratches. Some kind of proprietary shorthand, so no one else could read her work he guessed.*

*"Couldn't you have just brought the originals?" He asked.*

*The half-elf didn't look up. After a moment she distractedly muttered, "yes. And then they would know they had been stolen. We would have lost all chance of surprise."*

*Kiln shrugged and resumed his inspection of the room. The only other occupant was a human lad, seated to Kiln's right, arms crossed and looking both bored and mildly uncomfortable. There wasn't truly enough space for the boy between the table in front of him and the workbench behind. There wasn't enough space for him anywhere, it seemed, unless he was outside. Kiln watched as the human worked his thick fingers under his gorget to rub the raw flesh beneath. The lad had outgrown another set of armour and they couldn't afford to keep replacing it.*

*He returned his eyes to the half-elf, Veneranda was her name, who was now tapping one finger on the diagram as though she'd just noticed something new. Kiln knew better than to interrupt with a*

*question, so he waited. She had been away longer than he'd hoped this time. Most of the night was now gone, the faintest ruddiness in the eastern sky showing through the missing slats in the shutters promising that morning wasn't far off. But she'd been successful, that was certain, though she hadn't said as much. When the half-elf had slipped in through the back door, silent as a bat in flight and without a word spoken, he'd recognized the hint of a smile, more in the lines around her eyes than the shape of her mouth.*

*Any indication of a smile was gone when she finally looked up from the page. "It's two. Each is at least as big as what they have now, maybe bigger."*

*Kiln's heart sunk. Dwarves weren't known for optimism, but this was worse than even he had thought. "How..." he began to ask.*

*Veneranda anticipated his question. "The construction sites were disguised to look residential. They've been at this for a while now. We don't have much time."*

*The lad wore a confused expression. He clearly didn't share his companions' concern. "I don't see why we need to sneak around and spy on them," he said, "they have as much right to do business as we do."*

*The half-elf darted a sharp glare at the big human but Kiln raised a hand to stop any rebuke. "Listen Rig, there's hardly enough logging in this area to support two workshops as it is, and now it seems our competition is building two more workshops on top of the one they already run."*

*The lad blinked slowly. Nothing in his expression showed he grasped the implication of what Kiln was saying.*

*The dwarf thought for a second and then asked, "how many workers do we keep employed here, Rig?"*

*The boy's eyes drifted towards the ceiling. After a moment he replied, "a lot".*

*"Right. And what would happen to them if our competitors drove us out of business?"*

*The tactic worked. Rig's eyes slowly widened. "But the money they earn here feeds their families, pays their rent," the human said softly, "they'd all be out of work!"*

*More likely they would just go work for our competitors, Kiln thought, but the lad doesn't need to be bothered with details. There was a time he was reluctant to work with someone with so many morals, but now he saw how easily they could be manipulated and wished he'd realized it decades ago.*

*The half-elf was already gliding out the back door. "We'll take the long way and come up from the river bank in case there's a watch. Come on now, they might have guards," she said as she disappeared into the darkness.*

*"It won't matter if they do," Rig said slowly as he stood up from the table, his chair screeching against the floor as he shoved it back. He reached down to where his maul leaned against a workbench, hefting the massive cudgel effortlessly. "You know something, Kiln? It was a lot easier when we used to make money fighting monsters and such."*

*The dwarf clapped Rig on a well-muscled arm as he followed him out into the night air. "You have the right of it, lad, but there are only so many lost temples to plunder, so many evil wizards to thwart. And a man has to make a living."*

*At the far end of the alley, Veneranda's shadow detached itself from a wall and led them across a deserted street. The city slumbered; the constables dozed at their posts. The wet murmur of the river in the distance grew louder. Not loud enough to drown the noise of a pair of construction sites being smashed into kindling, but they'd be quick about it. A man needed to make a living after all, and tonight was as good a night as any for it.*

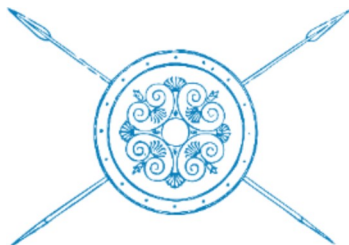

What is a business? Technically, any endeavour intended to generate a profit could be called a business. From that perspective, a lone musician busking on a street corner and the pickpocket working his way through the passing crowd are both "businesses". Even a party of adventurers making their way into a dungeon in search of treasure is a business. The rules contained herein are not intended to reduce the fun of adventuring down to a few abstractions, nor are they intended to reflect temporary efforts on the part of one individual.

There is a term useful to describing a business: A going concern. A going concern describes the underlying assumption that a business is financially viable – that it will continue to exist and operate from month to month for an extended, usually indefinite period of time. This distinction is important because while a player character may engage in a range of activities designed to generate income, a business is an independent entity that can (and does) operate apart from the player characters who own it.

For the purpose of the rules contained here then, we will define a business as a going concern owned by, but with an existence separate from, one or more of the player characters. This implies that the business has relatively competent and trustworthy employees ready and capable of running things while the player characters are off adventuring.

The *Dungeon Master's Guide* contains rules for running a business during adventuring downtime. For most players and dungeon masters, those rules are perfectly serviceable. They do have some limitations, however. One of the most noticeable of these is that the degree of profit a business generates is calculated without respect to the size of the business. Another is that the player character has only the most abstract ability to influence the business' operations, which some players may find unsatisfying.

The optional rules laid out here expand on the notion of player-owned businesses. Within you'll find information on different types of businesses

and how to invest in them, as well as the varying degrees of risk they invite. A system for determining market conditions, random events and the impact of management initiatives gives player characters a more hands-on approach to running a business. Other topics include adventure hooks resulting from player-owned businesses and the impact of magic on the economy of your Dungeons & Dragons game.

## Overview

The intent of these rules is to present players with options for owning and operating a business, balanced between the goal of simulating the problems faced by real business owners with the need to not bog down the game with dreary complexities. In order to accomplish this goal, business operations and the results of those operations are distilled to a few rule elements. Each is detailed fully further on, but a brief overview is presented here to familiarize the reader with the principal concepts before launching into a comprehensive discussion.

To begin, the nature of a business is defined by its type and culture. There is a nearly limitless number

of specific businesses a player may choose to run, but for the purpose of owning a business in Dungeons & Dragons, this complexity is reduced to a selection of four business types and six cultures. A key aspect of this is the risk factor. This is a simple concept representing the fact that some businesses have a higher chance of extraordinary profits, while inviting the possibility of extraordinary losses.

The next concept is investment. In the real world, accounting for a business is a lot of work. There are assets and liabilities, revenues and expenses and that's just the beginning. All of that detail is reduced in these rules to one simple concept – investment. A business' investment is a single value, typically expressed in gold pieces, that represents the basis for determining profits and losses (discussed more below) and also acts as a measure of the size of a business. This last point is somewhat subjective: A 750 gold piece farm may well be larger than a 500 gold piece farm, but the higher value could be due to something else, like a bigger barn or better access to fresh water.

The final set of concepts all have to do with determining the results of running a business. In other words, did the business generate a profit or



suffer a loss? At its most basic level, this is determined by a simple formula: the value of the investment multiplied by a percentage representing the return on investment. Most of the rules herein are involved with determining what that return on investment (or ROI) percentage is. Briefly, the influences on ROI are these:

- The market environment, broken down into the individual elements of economic, political, strife and competition, which determine how favourable conditions are to doing business;
- Management actions, which range from marketing initiatives to industrial espionage and sabotage, give player character business owners an opportunity to directly improve profitability;
- Random events, sometimes fortuitous and sometimes not, add an unexpected element to the business cycle.

Beyond these principal drivers of return on investment, profits can be further impacted by interest costs if the business is carrying any debt as well as a handful of other factors. These returns are calculated on a monthly basis.

Now that the fundamentals of these rules have been introduced, the remainder of this supplement delves more fully into each concept.

## Starting a Business

Whether a player character starts a business by building one up from scratch or by purchasing an existing concern, the most important thing to remember is that owning a business is a financial investment, and the reason to own one – in most cases – is to generate a return on that investment. The concepts of investment and return on investment are expanded upon in greater detail further on (see Return on Investment, page 24), but first it is worth examining the different types of business a player character can invest in.

## Types of Businesses

Most fantasy campaigns are modeled to a greater or lesser extent on a medieval time period. That assumption is carried through these rules. This assumption simplifies things, because a medieval economy is significantly simpler than a modern one. Having said that, even a medieval economy is still complex, with a dizzying array of raw material inputs, goods manufactured and services provided.

In order to meaningfully categorize the huge number of different types of businesses, they are organized into four groups.

### Resource

Any business that concerns itself with the basic, raw material inputs to the economy is a resource business. Mining operations produce stone, metal, gemstones and salt. Agricultural endeavours produce meat and vegetable crops as well as hides, wool, tallow, bone, flax, cotton and silk. Fisheries gather resources from lakes and the sea, while forestry operations produce wood. This is by no means an exhaustive list, but it does begin to illustrate the diverse range of materials a medieval economy makes use of.

The assets of resource-type businesses are varied, but typically are focused on ownership of (or at least the rights to make use of) relatively large amounts of land. They also usually need heavy tools and equipment like plows, mining carts and saws.



## Manufacturing

A massive variety of goods are manufactured from the raw materials generated by resource-type businesses. Most of these goods are also further manufactured into other goods, many of which are further manufactured into yet other goods, and so on. Although it would be impossible to fully list all the sorts of manufacturing businesses that can exist in a medieval economy, it can be helpful to work backwards from a particular type of finished good, envisioning all of the manufacturing steps required to produce that item.

Using a common item of clothing, a wool shirt, as an example, the manufacturing steps are these: First, the raw wool supplied by the rancher (a resource business) needs to be sorted by length and quality of fibre. Then the wool is washed, usually with solutions of lye or urine, and worked or beaten to further clean and untangle the wool. Next the wool may be dyed before being greased with fat or oil to prepare it for combing and carding, where the fibres are more fully separated and straightened. After combing, the wool is spun into yarn using a drop spindle or spinning wheel. Once the wool yarn is complete, weavers take over and use a loom to weave the yarn into wool cloth. The wool cloth is not yet ready to be used for clothing, though; first it needs to be further washed through a process known as "fulling" where the wool cloth is strengthened and thickened either by manually stepping on it or beating it with wooden hammers while soaking the cloth, again using lye or urine. Water-powered fulling mills may also be employed to partly automate this process. Once the cloth dries, it must be sheared and napped to remove any roughness from stray bits of fibre. Lastly, the cloth may be pressed and further dyed before it is complete. The finished wool is then cut and sewn by a tailor into a finished wool shirt, possibly with the addition of wood, metal or bone buttons. Many other processes would intersect with those described above, as the various tools and other products used to make the wool all have manufacturing processes of their own.

The above is a rather detailed view of the manufacturing process of wool clothing, but it serves to illustrate how many different businesses can be involved in manufacturing even a common item like a shirt. Between the sheep rancher who produces raw wool and the tailor who sells an article of clothing are as many as a half dozen other businesses critical to the process. If you're inclined to start a manufacturing business, it's worthwhile to research how things were made in the middle ages to gain a deeper insight into what sort of opportunities there are.

Manufacturing-type businesses typically comprise one or more buildings that serve as workshops or mills. These contain all of the tools needed by the business, which can be anything from tiny sewing needles to massive smelting furnaces.

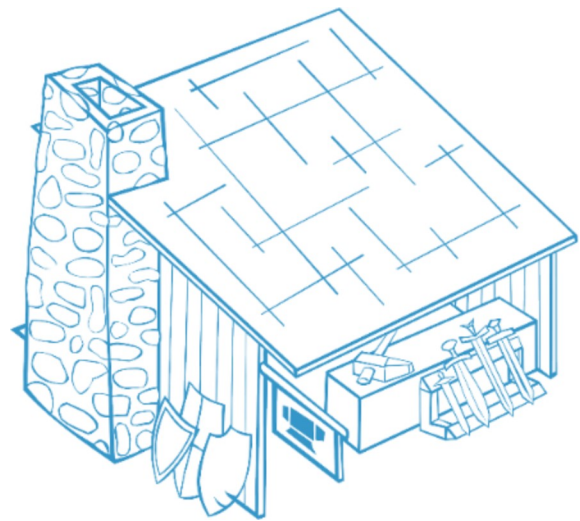



## Resale

The line between manufacturing and resale is defined by whether or not the business made the goods it is selling. Many manufacturing businesses, from blacksmiths to tailors, sell the products they make. A resale business is different: Resale businesses purchase goods from another business and then sell them again at a higher price, making their profits on the difference between what they paid and what they were able to sell for. Most resale operations are known as merchants and traders.

It is tempting to think of resale as the final step in the supply chain: Materials flow from those who gather resources to those who manufacture goods and finally to those who sell the finished products. This is not always true, however. Many merchants provide an important logistical role, moving goods through the supply chain. Using the prior example of wool cloth, a merchant likely collects bundles of raw wool from farmers, then resells it to the workshops who produce wool cloth. Merchants step in again to buy the cloth bolts in bulk, often transporting them great distances over land and sea to be sold again in distant markets.

What assets are owned by a resale business is dependant on whether the focus of the business is distribution over large distances or operation of a store that serves a local clientele. In the former case, assets typically comprise one or more warehouses along with vehicles: A single mule-drawn cart, a fleet of ships or something in between. In the latter case, the retail outlet can range from a market stall to a large trading post.

## Service

Service businesses tend to be less focused on assets and material goods than other business types. Instead they specialize in offering labour. The value of labour follows the same laws of supply and demand as the rest of the economy, meaning that when workers are in short supply even unskilled labour can be valuable, and skilled labour even more so. Successful service-oriented

businesses capitalize on this by providing specialized services where they are most in demand.

Example of service business are inns and hostels, messengers, cartage, security, stables, animal training, brothels, colleges and universities, guilds, theatres and mercenaries. Remember that the rules laid out here are intended to reflect ongoing businesses where an investment has been made and a return is expected. The income of individual service providers such as the lone mercenary, bounty hunter or thespian is better gauged by the lifestyle expense rules given in the *Player's Handbook*.

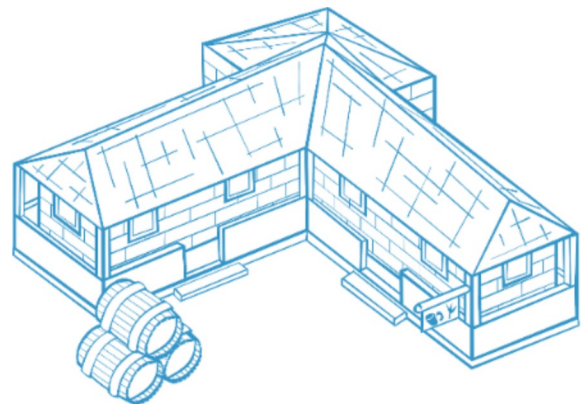

## Investment

Investment is used as an indicator of the size of a business. It is an amount of money that represents the value of the business' assets, including land, buildings, vehicles, tools, equipment and inventory. In short, the investment is what gives the business the ability to operate and generate revenue, and thus – with a little luck – produce a return on that investment.

One important point to remember is that investment encompasses a going concern's entire ability to generate a return. Flipping through the pages of the *Player's Handbook*, one would be forgiven for noting that the price of a longship is 10,000 gold, and from that assuming the investment needed to start up a shipping company with a longship is also 10,000 gold. Remember though that the ship requires a crew to man it, food and supplies for the crew, cargo to sell, working

capital for docking fees and bribes and so on. Because of this, the gross investment needed is almost always significantly more than the direct cost of the major assets. This is true whether the assets are ships, wagons, buildings of some sort, mines, quarries, perhaps even a forest or some other source of raw materials. Whatever the obvious elements of the business are, be sure that there are always many other necessary parts included in the gross investment value.

While investment is an abstract means of representing the ability of a business to generate a return, it is possible to describe what sort and size of business is reflected in a given investment level. Use the examples given in table 1 as a guideline.

**Table 1: Investment Examples**

Investment	Resource	Manufacturing	Resale	Service
100 gp	Share of a small farm	Outdoor one- or two-man smithy	Market stall with small inventory of local goods	Travelling theatre troupe
500 gp	Salt mine suitable for supplying a town or small city	Modest workshop	Several mule-drawn carts with drivers and cargo	Small hostel
1,000 gp	Local forestry and lumber operation	Foundry or similar mid-sized, complex workshop	Small to mid-sized shop with basic inventory	Well-equipped stable
5,000 gp	Large farm with abundant fresh water and pasture land	Simple mill, water- or wind-powered	Larger trading post with diverse inventory	Guildhall capable of serving a good-sized city
25,000 gp	Mid-sized gold mine	Complex water-powered mill such as a fulling mill	Pair of longships, with crews and trade goods	Large inn with kitchen and stables
100,000 gp	Rich gemstone mine	Large shipyard	Pair of large galleys, crewed and loaded with goods	Small mercenary army

The businesses listed in table 1 are merely examples. Virtually any size investment can be suitable to any type of business. Certainly, some may take a bit more effort to explain. A farm worth 100,000 gold would need to be vast and amazingly fertile. A gold mine worth only 50 gold might be just a small panning operation in a promising creek.

One final point on the topic of investment is that a single investment can, in some circumstances, comprise several businesses at once. This option is best employed when one or more owners invest in several similar businesses located near one another. For example, if a player character owns a dozen farms surrounding a single town, it makes sense to treat that as one large investment rather than twelve small ones. If the businesses are significantly different from each other, for instance if a player character owns a farm, a blacksmith and a cooperage (a workshop that manufactures barrels) all in the same town, it would be best to treat that as three separate investments. Similarly, if a player character owns a dozen farms all a fair distance away from one another, it too would be preferable to treat those as separate investments.

### Shared investments

A business need not be owned by a single person. An inherited business could have more than one heir; a new business could be started by several partners pooling their resources; an existing business could accept a new investor to help fund an expansion. In any event that a business has multiple owners, use the rules provided in this supplement to account for the entire business as a whole, single investment exactly as if there was a

single owner. When monthly profit or loss is calculated, special rules apply to divide the results among the owners (see Profit and Loss Considerations for Shared Investments and Business Combinations, page 27).

### Business Combinations

Not all businesses fit neatly into one of the four business types listed above. Consider the typical inn with a dining room or bar attached. The inn would be considered a service, while a dining room would be manufacturing and a bar would probably be resale. Another common example is a resource business that also performs some basic manufacturing processes, such as a mine that also smelts ore into useable metals or a forestry operation that also mills tree trunks into lumber. In these cases, there are three options available.

The first option is to divide the business into smaller businesses of different types. This works best for larger investments where the individual pieces are worth at least several

thousand gold on their own. A large inn could represent a 25,000 gold investment, but if that investment includes a dining room and bar it might make sense to treat it as three businesses, perhaps a 12,000 gold inn, 8,000 gold dining room and 5,000 gold bar. Using this option, each business would be accounted for separately even though they are physically attached.

The second option is to treat the business as a single entity and simply choose the business type that most closely reflects the business' operations. If the business is a mine with a smelting operation attached, it might be reasonable to declare that the mine is the larger and more significant part of the business, and hence the entire operation



should be simply treated as a resource business without worrying about the relatively small manufacturing component.

The third and final option is to characterize the business as being of mixed type, such as resource/ manufacturing or service/ manufacturing/ resale. This works best in situations where a business is roughly equal parts the different types and cannot be easily subdivided and accounted for separately because the components are too intertwined. The best way to judge whether business components are not suitable to be accounted for as separate businesses is to imagine what would happen if one of them went bankrupt. If the bar in an inn went bankrupt, the inn could likely continue to operate. On the other hand, if a mine went bankrupt could the attached smelting operation continue? Likely not if the smelter's entire input was from a mine that no longer functions. Using this option, the risk factor of the business becomes the average of each of the types included (see The Risk Factor, page 12).



### Buying a Business

Purchasing all or part of an existing operation is quick and easy, but there is a premium to pay for this convenience. The current owners will expect to be compensated not just for the value of the business' assets, but also for the earnings potential the business has demonstrated. See the discussion of goodwill on page 26 for more on this concept, but in the meantime it's enough to know that the purchase price of an existing business is equal to the value of the gross investment plus 20%. (This calculation is more complex for player characters

selling a business (see page 26 again), but when purchasing an investment from a non-player character, a simple 20% markup is used).

This 20% premium is not reflected in the gross investment value of the business once it has been purchased. For example, purchasing an existing business with an investment value of 2,000 gold pieces would cost 2,400 gold pieces, but the gross investment value of the business is 2,000 gold, not 2,400 gold.

### Starting From Scratch

An advantage to buying into an existing concern, or fully purchasing one outright, is that it avoids the complication of needing to construct the business from scratch. In many cases, building from scratch might not be possible to avoid, particularly if the business is of an unusual nature or located somewhere one wouldn't normally find a business operating.

The general assumption is that construction proceeds at a pace of 150 gold pieces worth of investment per day. At this rate, a 1,000 gold piece investment would take 7 days to complete. It is possible to increase the speed of construction. This requires the use of an expansion management action (see Management Actions, page 18). This is the only time a management action can be used prior to the business beginning actual operations.

Realistically speaking, there are many other considerations beyond construction when starting a business. Staff need to be hired and trained; inventory and tools need to be purchased. For many businesses, there is a lengthy process to conduct in order to make goods saleable. Consider a tannery, where animal hides may need to be soaked in tanning pits for a year or more before being ready to be used in leather goods. Other examples include almost anything in the agricultural industry: Raising animals and growing crops takes anywhere from a season to a number of years – you can't just build a farmhouse and a

barn and expect to take your products to sell at the market the next day.

Because of the staggering variety of businesses, no set assumptions on start up time are set beyond the basic assumptions on construction time given above. It is within the Dungeon Master's purview to rule that additional time must be spent on business operations before revenue starts coming in; however, for the sake of abstraction this additional time can normally be ignored. It can be assumed, for example, that a new business acquires saleable inventory wholesale to start its sales process prior to its own inventory being ready. Or perhaps the business engages in other, shorter term activities outside of its normal operations to help kick off its revenue streams. In any event, the process of starting a business should be handled in the spirit of the game: Fun and rewarding, not burdensome and punishing.

## Business Culture

Not every tavern is run the same way. Nor every blacksmith, guildhall, copper mine or any other sort of business. To help simulate this, each business has a culture which provides an ability or other benefit not enjoyed by businesses with different cultures. When starting a business, select one of the following cultures. If purchasing an existing business, the DM can choose what culture the business has, if any.

### Criminal

Some businesses are ethical, some are unethical and some are simply criminal. A criminal culture will break any law in order to defraud a customer, undermine a competitor or otherwise bend the rules in their own favour. In most societies, such a business would quickly find itself at best with no customers and at worst on the receiving end of the local justice system. In a less lawful society,



however, a criminal culture may be the norm and caveat emptor the general rule.

A business with a criminal culture has access to the sabotage management action (see Management Actions, page 18).

### Cut-throat

For some businesses morality is of little concern when profits are at stake. This is known as having a cut-throat culture. Customers are not always comfortable patronizing businesses that wantonly display a lack of ethics, so most cut-throat cultures try to present themselves as being traditional or some other culture to help obfuscate their shadier dealings.

Cut-throat cultures gain access to the espionage management action (see Management Actions, page 18).

### Front

One of the few examples of a business for which the primary goal is not profit, a front is intended to conceal some other activity behind a mask of routine commerce. This could be an underground political resistance movement, a temple to an outlawed religion, a devil-worshipping conspiracy or any other organisation that needs to keep its existence a secret.

Due to their lack of focus on actually running a successful business, fronts gain no special abilities or benefits related specifically to business; however, any employees of the front gain advantage on stealth rolls made to disguise their true activities as mundane operations of the business.

### Innovative

In many ways the opposite of traditional is the innovative culture. A business with an innovative culture values progress and finding new and better

ways to do things, whether it's a manufacturing process or a sales technique.

Having an innovative culture gives a business access to the invention management action (see Management Actions, page 18).

### None

It's entirely possible for a business to have no culture at all. Having no culture imparts no particular benefit, however. In practice, the only businesses that operate without a culture are those that are in the process of changing their culture.

### Traditional

The most common culture in most campaigns, traditional cultures value how business is done and who it is done with over profits. A business that has been handed down from generation to generation is likely to have a traditional culture, but even newer businesses can be traditional-minded.

Because they are generally seen as low-risk, traditional businesses pay only half normal interest costs (see Interest, page 22).

### Trendy

When trade caravans and merchant vessels travel to distant lands, they inevitably carry with them goods and ideas that become popular for the simple reason of their novelty. Businesses with a trendy culture latch onto these novelties in order to profit from them. The difference between trendy and innovative is that trends aren't about doing anything better; they're just about doing things differently. And once that difference becomes ordinary, they just go out and find a new trend.

A trendy businesses gives its investors advantage when they take the marketing action (see Management Actions, page 18).

## Changing Culture

It has been said that it takes years to build a reputation and only seconds to destroy it. For the purpose of these rules, business culture can be changed in three months. This represents the space of time required for the change of direction from management to be adopted by the business' employees and, if applicable, recognized by the business' customers.

Once the decision has been made to change a business' culture, the existing culture is immediately removed. While the business has no culture, it loses access to any abilities or benefits it received from its former culture. For three months the business operates with no culture. On the fourth month the business adopts its new culture and gains access to whatever ability or benefit that culture imparts.

## The Risk Factor

Not every business venture is a profitable one, and even successful businesses have bad months. It takes someone with an entrepreneurial spirit to be willing to risk the perils of investment. Even among entrepreneurs there are varying appetites for risk, though. While the potential for loss exists in all businesses, some types of business are inherently riskier – trading the potential for great losses for the chance at great profit. The metric for this potential is called the risk factor. It functions as a coefficient, magnifying the profits or losses for riskier businesses.

Resale businesses have the highest risk factor. This is because they carry significant inventory that they have to purchase. If that inventory is lost at sea, stolen by bandits, spoils due to age or simply needs to be sold at a loss, the investment suffers; however, resale businesses also have a chance for large profits if they find buyers willing to pay a premium for goods in short supply.

Manufacturing operations are less risky, as their inventories tend to be relatively smaller and aren't transported as often or as far. Resource operations are less risky still, and service businesses the least risky because they have little inventory and low expenses in general. At the same time, labour rarely sells for a premium and so service businesses have a smaller chance to produce large returns.

Table 2 summarizes the risk factors for different business types.

Table 2: Risk Factors

Business Type	Risk Factor
Service	x1
Resource	x2
Manufacturing	x3
Resale	x4

For businesses with a mixed type, the risk factor should be averaged among the types included. The resulting risk factor should then be rounded up to the nearest whole number. A service/ manufacturing business would have a risk factor of  $(1 + 3) \div 2$ , or 2. A service/ manufacturing/ resale business would have a risk factor of  $(1 + 3 + 4) \div 3$ , which rounds up to 3.

Risk factor is used when calculating a business' return on investment (see page 24).

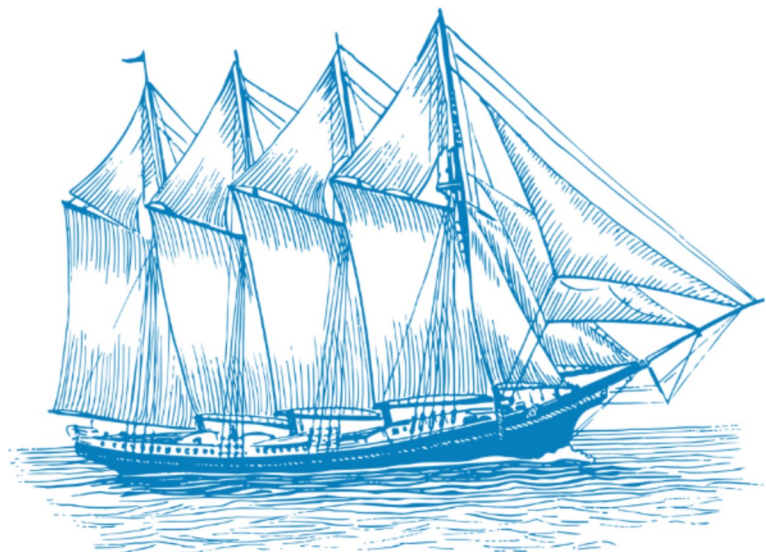

## Operating a Business

All businesses are assumed to be in continuous operation, with the consideration that shops are only open for normal business hours, that caravans set up camp for the night and so forth. The concept of a going concern is that other than for normal interruptions, a business is an enduring operation, one that functions independently of the player character or player characters who own it.

While businesses operate continuously, generating revenue and incurring expenses on an ongoing basis, the results of business activity are accounted for using a monthly cycle.

### The Monthly Business Cycle

Every business has an operating cycle. This cycle comprises all the activity and time needed to gather materials, prepare those materials for sale, conduct the sales process and begin again. The specifics vary from one business to another. For resource businesses, the procurement of materials occupies most of the cycle, where preparation for sale and sales processes are generally simple and quick. In resale businesses the opposite is true, with the process of selling goods being their principal effort. The time it takes to cycle through these operations also varies. A bakery could conduct all of its manufacturing and sales in a single day, starting each day fresh with zero inventory. An iron mine might spend many days building up an inventory of ore, only selling once massive quantities have been accumulated.

To smooth out these differences and allow for uniformity in determining business results, a month is used as the common denomination of time to meaningfully aggregate profits or losses. Every month that the business is in operation, a combination of market environment, management actions and random events determines the relative success of the business in that month.

Every month, a business owner will generally do the following:

- Determine the market environment
- Check for random events
- Declare and resolve any management actions
- Calculate all the impacts to the business' ROI
- Determine the closing gross investment
- Calculate the net profit or loss

These steps are given a detailed treatment starting on page 24. The specific timing during the month as to when the business owner completes these tasks is left somewhat open. Generally, it's best to determine random events early in the month so that corrective management actions can be planned, if necessary. That's not to say that all random events occur on the first of the month. Once the occurrences of the month are known, it can all be considered when developing a descriptive narrative that helps give life to the mechanics given here (see page 15 for more thoughts on narratives for business activity).

#### Adding Percentages

Throughout these rules, many possible adjustments to return on investment are given. This is typically shown as a plus or minus to a percentage, such as +2% or -1%. These adjustments are intended to be incremental or decremental to the whole integer value of the percentage they modify, not literal percentage-based adjustments.

For example, a base ROI of 10% that is adjusted by +2% is properly calculated as 12%, not as 10.02%. Similarly, an ROI of 15% modified by a -1% ROI impact becomes 14%, not 14.99%.



## Market Environment

One of the sad truths of running a business is that many factors that greatly influence the business' success are completely outside of the owner's control. To simulate this, for every month a business operates four aspects of the market environment are randomly determined with a 3d6 die roll. These aspects of the environment are economic, political, strife and competition.

Consult Table 3: Market Environment to determine the condition of each market aspect for the month.

Table 3: Market Environment

3d6 Roll	Condition	ROI Impact	Roll Modifier
16 or higher	Propitious	+3%	+4
13 - 15	Favourable	+1%	+2
9 - 12	Neutral	none	none
6 - 8	Unfavourable	-1%	-2
5 or lower	Adverse	-3%	-4

Market conditions normally change slowly. It would be unusual for the economy to be terrible one month, outstanding the next and back to terrible the month after. The roll modifier column is used to simulate this. This modifier doesn't effect the current month's roll; instead, it is used to modify the following month's determination of market conditions. For example, if the economic market condition is propitious in one month, the next month's check for the economic market condition is made with a +4 bonus.

It should be noted that these market conditions are determined independently for every business, even businesses that are located close to each other. At first that might seem odd. One could expect these conditions to be ubiquitous, that a shop on Maple Street wouldn't be experiencing a booming economy while a shop on Beech Avenue suffers in a recession. The reason each business rolls market environment independently is that the conditions are meant to reflect the market relative to that specific business, not relative to the entire market as a whole. It's possible, for

example, for the iron horseshoe industry to be booming while the linen table wares industry stagnates. More detail is provided for each aspect of the market environment below.

### Economic

If currency is the life's blood of the economy, this market condition determines the heart rate. The economic condition reflects how much available money people have to spend and how optimistic they are that they can afford to spend it, rather than saving it for some unforeseen need. It also

measures how much wealth is flowing into a local economy, whether from trade surpluses as merchant caravans roll into the area, nobles lavishly spending or adventurers enjoying the sudden wealth that occupation sometimes bestows.

### Political

Governmental policy can have a dramatic effect on business. The two most obvious examples are taxes and trade tariffs, which can directly impact the bottom line of all businesses. The political climate goes beyond these examples, though. Governments often intervene in culture and commerce with sumptuary laws, property use restrictions, asset seizures under marshal law or eminent domain laws, trade embargoes and a vast number of other possibilities.

### Strife

Nothing puts more of a sudden damper on commerce than a condition so dangerous people refuse to engage in commerce out of fear for their own safety. Strife is a catch-all market condition for such events as wars, extreme weather, riots, rampant crime or any condition that can likely be considered imminently dangerous. It's important to keep in mind the relative quality of the market environment, however. A war is likely to dampen

trade and reduce harvests, but the weapon and armour smiths suddenly see their profits increase enormously. Monsoon season might flood the local mine, but the roadside inns do a roaring trade with people desperate to get off the muddy roads and into a warm bed.

### Competition

If there are profits to be had, one business will rarely be left alone to take them all for itself. Inevitably, other entrepreneurs step in with ventures of their own and competition results. This is great for the consumer, as competition tends to increase selection and quality while driving down prices, but it's not so great for the business owner watching someone steal his customers.

### Developing a Narrative for Market Conditions

From a strictly mechanical perspective it isn't necessary to describe the market conditions a business is experiencing any further than the propitious-through-adverse scale given in the market condition chart. From a role-playing perspective, and to integrate the business more fully into the ongoing events of the campaign, it can be advantageous to build a narrative.

Once the market conditions for a month have been rolled, imagine them relative to the operations of the business. All conditions are relative, so a propitious condition can mean something very different for different businesses. Consider the following example:

A copper mine operates in the hills a few miles from a mid-size town. In a given month, the mine's economic condition is favourable, political is propitious, strife is unfavourable and competition is adverse. One possible narrative for this is that commerce in town is fairly strong and demand for copper is good, aided by the fact that the local baron has eliminated taxes and tariffs on metal production in order to stimulate the industry. So far, it's looking like a good month. Unfortunately,

bandit raids have been delaying shipments of ore to the smelter in town. Also, the baron's incentives seem to be working too well as a rival mine just started operating not far away.

In the next month, the economic situation is unchanged at favourable. The political situation drops to neutral while strife drops to adverse and competition improves to unfavourable. The demand for copper is as strong as ever, but it seems the baron had been losing too much revenue and has reinstated normal taxes and tariffs. The adverse strife condition indicates that those bandit raids have gotten a lot worse, seriously hindering access to the smelter. That rival mine seems to be struggling as well... could it be that the bandits are in their employ?

See adventure hooks on page 31 for more ideas on tying business ownership to the player characters' adventures.



## Random Events

Unexpected occurrences can have a significant impact on a business' performance, for good or for ill. Every month that a business is operating, roll 1d6. If the result is a '6', a random event has occurred. Roll 2d6 and consult table 4 to see which specific event.

Table 4: Random Events

2d6 Roll	Random Event
2-3	Devaluation
4-5	Malfunction
6	Cancelled contract
7	Theft
8	Illness
9-10	Fair
11-12	Appreciation

Details on each event's impact on the business are given below.

### Appreciation

The assets of the business have increased in value. This might be due to changes in land value, scarcity of rental spaces, increasing cost of replacing tools and equipment or some other cause. Whatever the reason, the business is now worth more than it was previously. Roll 2d6 and increase the gross business investment by that percentage. For example, on a roll of 8, a 1,000 gold investment would become a 1,080 gold investment. This change takes place prior to calculating return on investment for the month.

### Cancelled contract

The business has lost a major customer, either due to a formal cancellation of a contract or some other loss of a prior business relationship. This reduces the return on investment of the business by 5%. This loss persists every month thereafter. If this event is rolled again, the return on investment adjustment is added again, making the return on investment adjustment a net negative 10%. This continues if further cancelled contracts events

occur, with no limit to how large the negative adjustment to the business' returns can become. Successful completion of the negotiation management action removes these adjustments (see Management Actions, page 18).

### Devaluation

This event is identical to appreciation, except that circumstances have conspired to reduce the invested value of the business rather than increase it. The reasons for this are similar to those listed for appreciation, simply with the opposite effect. Roll 2d6 and decrease the gross business investment by that percentage. On a roll of 11, for example, a business with a gross investment value of 1,000 gold would become a 890 gold piece business. This change takes place prior to calculating return on investment for the month.

### Fair

Fairs attract merchants, artisans and most importantly customers from a wide area. Any business in the area when a fair takes place can be sure to benefit from the increased activity, as the festive atmosphere and exotic goods entice buyers and loosen purse strings. A fair increases the economic market condition by two grades, to a maximum of propitious in the current month only.

### Illness

A contagious sickness has spread among the employees of the business. It probably isn't fatal, but it does reduce the capabilities of the workers to the bare minimum. No management actions may be performed by the business in the month where an illness event occurs.

### Malfunction

Something has gone wrong with one of the business' critical assets. Most likely this is a piece of equipment, a tool or possibly a building structure, but whatever broke is going to cost the

business money until it can be repaired or replaced. A Malfunction reduces the return on investment of the business by 5%. This loss persists every month thereafter. If this event is rolled again, the return on investment adjustment is added again, making the return on investment adjustment a net negative 10%. This continues if further malfunction events occur, with no limit to how large the negative adjustment to the business' returns can become. Successful completion of the maintenance management action removes these adjustments (see Management Actions, page 18).

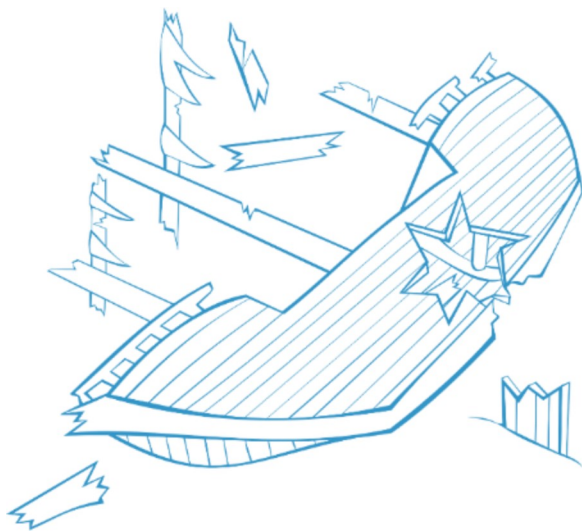

### Theft

The business has fallen victim to thieves. All businesses must eventually deal with the shoplifters, fraudsters and robbers who make a living taking what belongs to others, but this theft was significant enough to visibly reduce the concern's profits for the month. Return on investment is decreased by 5% for this month only.

### Discounts and Personal Use

When the player characters run their own business, the temptation will often exist to make personal use of the assets and merchandise. A weapon shop offers an inviting inventory of goods for adventurers, for instance. An inn is a welcoming place to eat and rest for free. A mercenary outfit could provide hired swords to aid an adventuring party in their battles.

As a general rule, any use player characters make of businesses they own should be at the standard rates and prices as given in the *Player's Handbook* and other supplements. It might seem strange that a character who owns a business can't get a discount on its products, but there is a good reason for this.

The most important idea to consider in regard to discounts is that the goods and services a business offers are not without cost to that business. Inventory costs money to stock, and employees providing services expect to be paid. Because of this, any free services or discounted goods would represent a direct diminishing of the business' profits for that month.

In other words, the players could take liberties with the products of their businesses, but the cost of such use would need to be subtracted from the gross profits of the business at month end anyhow, meaning that the net impact would be no savings at all. In a situation where the business has multiple owners this is even more serious as it would essentially mean the player character was stealing from his partners.

To avoid this complexity and the resulting negative implications, the rule therefore is that player characters pay for goods and services just like everyone else, irrespective of the investments they own.

## Management Actions

A business owned by a player character operates whether she is around or not. The advantage to actually being around to run the business instead of letting the employees take care of everything is that a player character is capable of taking management actions to help boost the profitability of the business.

Taking a management action requires the owner to make an ability check. The descriptions for each action below tell you which ability should be used for this check. The base DC for all management actions is 30. Every day spent on the action reduces the DC by 1, to a minimum DC of 5. The ability check is always made after the time has been invested, never before or during.

A business can only attempt one management action at a time. If the business has more than one owner, one of the owners can use the help action to give the player character attempting the management action advantage on her roll; however, the helper must spend the same or a greater amount of time on the management action as the player character making the roll. Attempting management actions or helping another attempt a management action is restricted to player characters who own at least 10% of the business' total investment.

Time invested in management actions can carry over from month to month; that is, a player character could spend the last 5 days of a month working on a management action, then continue spending another 10 days in the next month in order to make the management action check with a DC of 15. The time spent on management actions must be contiguous – if any day passes without the management action being worked on, the management action ability check must be made at that point or else the count of days spent on the action starts over. The result of the management action always effects the month in which the management action is completed.

Under some circumstances, the Dungeon Master may increase or decrease this DC. For example, if a

business attempts the same management action month after month, the Dungeon Master could rule that such repeated attempts have a diminishing effectiveness and increase the DC to compensate, or simply disallow the action.

Refer to table 5 to gauge the results of the management action:

Table 5: Management Action Checks

Ability Check	Result
Exceed DC by 5 or more	Outstanding success
Meet or exceed DC	Successful action
Fail to meet DC	Failed action
Fail by 5 or more	Catastrophic failure

The descriptions of the different kinds of management actions below detail the specific outcomes for each type of result.

### Contract Labour

The contract labour action allows an investor to bring in a skilled worker to perform management actions on her behalf. This worker acts like a consultant, working alongside the business owner, providing guidance in areas the owner lacks expertise.

In order to take the contract labour action, select any other management action for the consultant to perform (assuming the action is allowed by the business' culture). That action is carried out as normal, with the owner choosing how many days to spend on the action and an ability check being made to determine the success or failure of the attempt. The difference is that with the contract labour action, the ability check is made using the consultant's ability score instead of the owner's. This ability score is assumed to be 16 (for a +3 bonus on the ability check). Since the owner is considered to be helping the consultant, the check is also made with advantage.

The only drawback to using the contract labour action is cost: For every day the consultant works on the requested management action, the business must pay 3 gold pieces. This cost is paid

at the end of the action, in the month the ability check is made, irrespective of the outcome of the check. The total cost is subtracted from the month's profit (or added to the month's loss).

Example: A flour mill is in need of maintenance, but the owner of the mill, Thurg the Thick, has doubts about his odds of successfully carrying out an Intelligence-based maintenance action. Thurg instead takes the contract labour action, requesting the hired consultant to oversee the maintenance. He hires the consultant for 15 days. When the management action check is made, it is against DC 15 using the consultant's Intelligence of 16, with advantage. The mill's return on investment for the month will be reduced by the 45 gold consultant's fee (15 days times 3 gold per day).

If 3 gold pieces per day is too steep a price, a consultant can be hired for 2 gold per day, but his ability score is only 14 for the purpose of management actions. At 1 gold per day, a consultant with an ability score of 12 can be hired.

### Espionage

Most people think of spies as the agents of military or governmental organisations, but industrial espionage has existed for almost as long. Spying on competitors can have a number of benefits, including learning of marketing or expansion plans, discovering the identity of backers or silent partners and uncovering secret recipes, manufacturing techniques, trade routes and customer lists. Because of the ethical implications of spying, only a business with a cut-throat culture may conduct an espionage management action.

A successful espionage action improves the competition market condition by one grade (unfavourable becomes neutral, neutral becomes favourable and so forth). An outstanding success increases the competition market condition by two grades. On a failed check there is no impact, but on a catastrophic failure the information gathered is misleading and the competition

market condition worsens by two grades. This effect lasts only a single month (although the bonus or penalty to the subsequent month's market environment rolls can prolong the benefits or penalties associated with attempting espionage). Note that the best possible market condition is propitious and the worst possible is adverse, irrespective of the outcome of an espionage action.

Espionage actions are resolved using a Wisdom ability check.

### Expansion

Most successful businesses will eventually want to grow. Such growth is represented by an increase in the total invested value of that business. Added investment requires the oversight and expenditure of funds of the owner. The base amount of investment that can be added to a business is equal to 150 gold pieces per day. This represents the time needed for new construction as well as all related activity like training new staff, acquiring new land, expanding inventory and so forth.

While time must be spent on the expansion action in order to grow an investment at the 150 gold base rate, no ability check is required. It is possible to expand more rapidly by making an Intelligence check. On a successful check, the rate of expansion increases to 400 gold per day. With an outstanding success, the expansion rate increases to 1,000 gold per day. This reflects the player character's ability to oversee larger and more complex construction processes.

If an expansion check is failed, the investment rate slows to 100 gold per day. If the result is a catastrophic failure, the project has been so mismanaged that the rate of investment drops to zero – no progress has been made.

This management action can also be used in the construction of a new business (see Starting From Scratch, page 9). Keep in mind that there is no inherent minimum or maximum number of days this action can be attempted over, so it might be

advantageous to break up the action over a number of separate attempts to minimize the risk of losing significant time to a catastrophic failure.

As previously mentioned, expansion management action checks are made using Intelligence.

### Invention

By today's standards, where products are obsolete within months and new advancements are announced daily, the rate of progress in a medieval economy would seem astonishingly slow. Still, technology does march on at a measured pace and businesses that focus on improving their products and processes can benefit greatly. Only a business with an innovative culture can attempt an invention management action.

When a business owner attempts an invention action, she makes an Intelligence ability check. If the result is a success a meaningful advancement has been made, improving the business in a measurable way. This is simulated by increasing the size of the business' gross investment by 2%. Should the result be an outstanding success, the increase is instead 4%. For example, a 1,000 gold piece investment value would become 1,020 gold pieces on a successful invention action, or 1,040 gold pieces on an outstanding success.

On a failed invention check, no change to the business' investment value occurs; however, on a catastrophic failure the invested value of the business instead decreases by 4% as a promising development turns out to actually leave the concern worse off than it was doing things the old way.

These changes to the investment value of the business are applied prior to calculating the return on investment for the month, so they have an immediate effect on profits or losses.

As mentioned above, invention management action checks are made using Intelligence.

### Maintenance

All businesses must put some effort into keeping their assets in working condition. Retail outlets try to keep the shop presentable for customers; workshops keep the tools in working order, and so on. While a certain ambient level of care and attention to an investment's assets is expected as part of routine operations, the maintenance management action involves a more directed and strenuous effort to keep the business functioning at peak efficiency, over and above what the staff are able to organize without direct input from the owner.

The effects of one or more malfunction random events that have already occurred are removed by a successful maintenance action; otherwise this action negates the next malfunction random event that occurs. An outstanding success has the same effects, but also negates one additional malfunction random event in the future.

A failed maintenance attempt has no effect – any future malfunction event occurs as normal and any current effects of malfunction events continue. A catastrophic failure indicates a maintenance action so poorly conducted it immediately results in a malfunction event occurring (see under Random Events, page 16).

Maintenance management action checks are made using Intelligence.

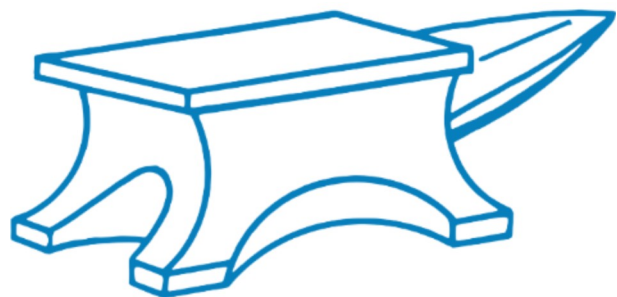

## Marketing

Marketing involves attempts to establish or improve a business' relationship with its customers. This often takes the form of advertising for new customers or socializing with existing customers.

A successful marketing action directly improves the business' return on investment by +2% in the month the action is completed. An outstanding success instead increases the return on investment by +4%.

If a marketing attempt results in a failure, no ROI change takes place. Unfortunately, if a catastrophic failure occurs the marketing effort was so botched it results in a -4% change to that month's return on investment.

All marketing management action checks are made using Charisma.

## Negotiation

This action reflects the efforts of a business to set the best possible terms in its customer relations. This might be formal contract negotiations, re-establishing business relations with former clients or simply haggling over prices.

If a business is suffering the effects of one or more cancelled contract random events, a successful negotiation action negates those effects; otherwise it negates the next cancelled contract random event that occurs. An outstanding success has the same effect, but also negates one additional cancelled contract random event in the future.

A failed negotiation attempt has no effect – any future cancelled contract event is not negated and any current effects of a cancelled contract event continue uninterrupted. A catastrophic failure

indicates a negotiation attempt so inept it immediately results in a cancelled contract event occurring (see under Random Events, page 16).

Negotiation management action checks are made using Charisma.

## Sabotage

Unethical and illegal, sabotage can also be very effective. This action is only available to those businesses that have a criminal culture. The effects of sabotage have much in common with espionage – both involve directly undermining competitors. Where espionage is subtle, however, sabotage is anything but, instead attempting to directly harm

competing businesses by damaging or destroying their assets.

A successful sabotage action improves the competition market condition by one grade (unfavourable becomes neutral, neutral becomes favourable and so forth). An outstanding success increases the competition market condition by three grades.

On a failed check the competition market condition is unchanged, but the political environment worsens by one grade. On a catastrophic failure, the political market condition worsens by three grades. This reflects the impact of fines and other sanctions, possibly including prison terms for employees, brought by local authorities in response to the business' illegal activities. Note that the best possible market condition is propitious and the worst possible is adverse, irrespective of the outcome of a sabotage action.

Sabotage actions are resolved using a Wisdom ability check.





## Training

Time invested in developing the skills of employees is rarely wasted, as a skilled workforce is capable of handling all eventualities better than an amateurish one. A successful training management action gives the business advantage on the next management action attempted after the training is complete. An outstanding success instead gives advantage on the next 3 management actions attempted.

A failed training action has no negative repercussions, but a catastrophic failure means the staff are so confused by what the owner attempted to teach them the business gets disadvantage on its next management action after the training is complete.

Training management actions are resolved using Wisdom as the relevant ability.

## Interest

Under certain circumstances a business may choose to, or be forced to, take on debt. This is most often the result of unprofitable operations, where business costs need to be covered by short term loans (see Debt, page 26). Under a capitalist economy, debt can also be used to purchase an investment (see Feudal and Capitalist Economies, page 29).

Any time a business begins a month with a debt balance, interest expense must be calculated. This expense reduces the net return on investment of the business in that month. To calculate interest expense, multiply total debt at the month's beginning by 20% and divide by 12, rounding down to the nearest copper piece.



## Modifying Rate Percentages for Different Calendars

Throughout these rules, percentage rates are used for the calculation of return on investment and interest expense. These rates are presented in all cases as annual rates. (This is why calculations for interest expense and ROI require you to divide by 12 – it reduces the annual amount down to a monthly amount). Annual rates are used because they're easily understood – in the real world, if you're given a percentage rate it will almost invariably be an annual rate.

This works well in real life, and it works well in a Dungeons & Dragons campaign set in the Forgotten Realms. In Faerûn, the year is also 365 days, divided into 12 months roughly analogous to a real calendar (for purposes of accounting for a business in the Forgotten Realms, ignore any special calendar days that fall in between months).

However, if your campaign takes place in a setting with a different sort of calendar, these assumptions may not work as well. A different setting could, for example, have a year that's only 200 days long, divided into five months of 40 days each. Or it might not have months at all – a world with no moon, for instance, would likely have the year divided into seasons or some other grouping of days rather than a period roughly analogous to the phases of the moon.

In cases where a campaign uses an unusual calendar, a little bit of math is needed to translate the rates provided in these rules into percentages useable in another setting. Fundamental to this math is a simple concept – the percentages given herein are meant to represent 365 days of business activity, more or less. In order to translate them to another time frame, simply divide the rate by 365 and multiply it by whatever new period you desire.

For example, the world of Zurrus has a smaller orbit than Earth. Its year is only 310 days long. Lacking a moon, the people of Zurrus have never considered the concept of a month. Instead, they divide the year into the four seasons, each being 77 days long, with an extra day at mid-summer and mid-winter. The Zurrus calendar divides these seasons into 11 weeks of 7 days each. For this example, many of the concepts used in these rules would not work properly. The basic concept of annual rates needs to be adjusted, as does the idea of accounting for business operations on a monthly basis.

To correct the annual percentage rates, use the rate of a single day as the basis. In this example, if the ROI was determined to be 14%, we could restate that as a daily rate of 0.0384% ( $14\% \div 365$ ). Multiply that by the number of days in a Zurrus year gives us a Zurrus year equivalent rate of about 11.9% ( $0.0384\% \times 310$ ). (If you're comfortable doing so, you could do this in one step by multiplying 14% by  $310/365$ ). We would use this conversion method when calculating ROI and interest expense, and we would also likely divide the year into something other than 12 periods, since the Zurrus calendar doesn't work that way. We could have 4 periods, corresponding to the seasons, 44 periods, corresponding to the weeks, or something in between. Whatever period you choose, substitute the number of periods in a year for 12 when calculating ROI or interest. For instance, if you account for business on Zurrus seasonally, you would convert the percentage rates as outlined above and divide the result by 4 to determine the result for a single season.

## Return on Investment

At the end of every month a business operates, the owner must calculate the return on investment. If the business has more than one owner, any owner who is a player character performs this calculation on behalf of all owners. Multiple player character owners can decide among themselves who will calculate returns for the month.

### Step 1: Base Return on Investment

Base ROI is assumed to be 10% for all businesses. This is due to a simple fact: No one wants to invest in a business likely to generate a poor return, or worse yet to operate at a loss. Because of this, all business ventures are presumed to be capable of generating a modest yet healthy return of 10% on their investment, subject to considerable variability as outlined in these rules. Note that the interest rate is an annual one – hence when calculating profit or loss for the month, the result is divided by 12.

### Step 2: Market Environment

Roll for the four elements of market environment: economic, political, strife and competition, as outlined on page 14. Remember that these market conditions may be altered by random events or management actions, which is covered in steps 3 and 4.

### Step 3: Random Events

Determine if a random event occurs, and if so which event specifically as given on page 16.

### Step 4: Management Actions

Decide on management actions, if any, and resolve their outcome as described beginning on page 18.

### Step 5: Finalize Market Environment

Revisit the market conditions determined in step 2 and modify them if necessary based on the outcomes of steps 3 and 4.

### Step 6: Finalize Investment

Determine the final gross value of the business' investment. Remember that this is the gross investment representing all ownership, not just the ownership portion of the player character calculating the ROI. Random events and management actions can also modify the investment, so consider those as well if applicable.

### Step 7: Finalize Return on Investment

Sum the base ROI given in step 1 with the ROI impacts of the finalized market environment determined in step 5. Also add any other ROI adjustments per the effects of random events and management actions, if applicable.

### Step 8: Apply Risk Factor

Multiply the finalized ROI determined in step 7 by the business' risk factor to determine the risk-weighted return on investment.

### Step 9: Determine Gross Return

Multiply the risk-weighted ROI from step 8, positive or negative, by the finalized gross investment total determined in step 6. Divide the result by 12 and round down to the nearest copper piece to determine gross return on investment.

### Step 10: Calculate Interest

If the business carried any debt at the start of the month, calculate the interest expense as described on page 22.

### Step 11: Determine Net Return

Reduce gross return by the amount of interest expense, as well as the amount of any other adjustments such as contract labour costs. This final amount is the business' net return for the month.

### Step 12: Determine Monthly Performance

Dependant on the net return, the monthly performance can be profit, reinvestment, debt, shrinkage, divestiture or bankruptcy. See below for a description of these results.

### Step 13: Update Business Sheet

The business sheet needs to be updated with the current state of the business after every month end (see the business sheet sample on page 37). This is important as the results from one month directly influence the next month when it comes to rolling for market environment, and potentially for subsequent months if the business is carrying debt. Any updates to gross investment need to be tracked as well.

The business sheet also tracks year-to-date profits or losses. This is not merely for curiosity's sake – this is used in calculating annualized revenue, which is a key component in the calculation of goodwill if divestiture should occur (see Divestiture, page 26).

## Monthly Performance

Once the results of business for the month are known, it becomes necessary to take stock of the situation and make a judgement of the best path forward. Ideally, the business is successful and operations will continue, but this isn't always the case. The monthly performance of a business is defined as one of the concepts expanded on below: profit, reinvestment, debt, shrinkage, divestiture or bankruptcy.

### Profit

If business operations proceed as they should and the market conditions aren't overly unfavourable, any business should be able to realize a profit. Profit is the default result of monthly operations – it's the reason people start businesses in the first place. If the return on investment in a month is anything greater than zero, and interest and other costs don't exceed gross returns, the monthly performance is profit. In this situation, the owner would pocket the profits for herself (or have them held for her until she returns) and continue business as usual in the next month.

When a business has more than a single owner, the profits need to be split among the owners group (see Profit and Loss Considerations for Shared Investments and Business Combinations, page 27).

### Reinvestment

When revenues are less than expenses, the result is a loss; if ROI is negative, this is what has happened. Hopefully this doesn't happen often, but when it does the bills still need to be paid if business is going to continue. Reinvestment is often the best option in this case. This represents the owner or owners stepping in with additional funds to ensure the business stays viable.

The amount of reinvestment needed is equal to the amount of the loss the business sustained in the month. If the net return for the month is a loss of 50 gold pieces, a 50 gold piece reinvestment is needed to keep the business running. Despite the name, it should be noted that reinvestment does not in any way change the gross investment value of the company – instead it stops that investment value from decreasing.

If the business has multiple owners, the cost of reinvestment should be split among them (see Profit and Loss Considerations for Shared Investments and Business Combinations, page 27).

One final consideration for reinvestment is the availability of funds. If the owner lacks the cash needed to pay for the reinvestment, this option is

unavailable. Similarly, if the owner is absent (perhaps off on an adventure somewhere), she may not be able to contribute the funds needed to make this a viable option.

### Debt

When funds for reinvestment aren't available, the next best option may be to borrow funds on a short-term basis. Money lenders in a medieval economy tend to charge very high rates of interest by modern standards, but incurring some interest expense is often better than losing all or part of an investment.

Debt can also be used in combination with reinvestment or shrinkage. If monthly losses totalled 20 gold pieces, for instance, the owner could pay 10 out of pocket and take on 10 gold pieces of debt to cover the remainder.

In general, debt is assumed to always be available. There is a limit to the amount money lenders are willing to extend, however, before the risk of the loan becomes too great: No business may carry debt in excess of its gross investment value.



### Shrinkage

If reinvestment and debt are not available, or not desirable, the next option is shrinkage. This reflects the business being forced to pay its costs by selling off assets, shrinking the workforce, bartering with inventory or some other means of keeping the business afloat by trading away part of itself. Using this option, the gross investment of the business decreases by the amount of the month's losses.

### Divestiture

Divestiture is a fancy word for selling a business, or part of a business. An owner may sell for many reasons, such as to free up funds for some other venture or to stop the bleeding if ongoing losses are becoming unsustainable. The basic assumption is that an investment sells for its own value. Selling a 500 gold piece business, or a 500 gold piece portion of a larger business, should net you 500 gold pieces. This amount is reduced by the amount of any debt the business is carrying. One other adjustment is the concept of goodwill.

In modern parlance, goodwill is an intangible asset representing the value of a business above the net value of its assets. What that basically means is that a business might sell for more than its direct value because the business has a proven ability to generate returns, and so those future returns are factored into the selling price. On the business sheet, a space is reserved to record the year-to-date profits or losses. That amount is tracked for the purpose of calculating goodwill.

To calculate goodwill, take the year to date profits or losses, divide them by the number of months those returns represent, and multiply by 12. That gives you an annualized profit or loss amount. Multiply these annualized returns by 2 to get total goodwill. That amount should be added to the gross investment amount to determine the selling price (or subtracted in the case of a loss).

There are two further ideas to note about goodwill: First, that if only a portion of a business is being

divested, the goodwill amount should be adjusted to reflect the same proportion; second, that if once goodwill is factored in, the total selling price of the investment is zero or negative, the investment has no sales value and can only be nullified as per the bankruptcy rules (see Bankruptcy below).

For example, a business has a gross investment value of 1,000 gold pieces. The owner decides to divest half this business to free up some capital, thus she is divesting a 500 gold piece investment. Four months have passed in the current year, during which the business has been sustaining losses totalling 80 gold pieces. To calculate goodwill, the owner would divide 80 by 4, then multiply by 12, which yields an annualized loss of 240 gold pieces. Multiplied by 2 gives a total goodwill of -480 gold pieces. Since only half the investment is being divested, she would only include half the total goodwill, or -240 gold pieces. This means the investment being divested has a selling price of 260 gold pieces.

### Bankruptcy

The final option, should all else fail, is to simply walk away. Using the bankruptcy option, the gross investment value of the business falls to zero and it ceases to exist.

### Profit and Loss Considerations for Shared Investments and Business Combinations

In any case where a business has multiple owners, there are only two changes to be made in applying these rules. First, any profit from the business is shared among the owners proportional to each owner's share of the total investment. For example, a business with a total investment of 4,000 gold is owned by three player characters: One has a 2,000 gold piece investment and the others have 1,000 gold invested each. In a particular month that business generates a profit of 50 gold pieces. The player character with 2,000

gold invested would keep 25 of the 50 gold. The other two would keep 12 gold and 5 silver each.

Second, any loss incurred by the business must also be shared. When a shared investment suffers losses, the choice of reinvestment, debt, shrinkage, divestiture or bankruptcy must be mutually agreed upon by all owners. In the case of reinvestment, each owner contributes according to her investment portion, exactly as is outlined above for the sharing of profits.

For business combinations, generally no special provisions need be made. If a single enterprise is being accounted for as separate businesses, for instance an inn with a dining room and bar, it's entirely possible for one of the businesses to be profiting while the others are not. It's even possible for one or more parts of the business to go bankrupt independently – the inn in question may have had to close down its rooms and kitchen due to lack of business, but the bar is still going strong.



## New Background – Family Business

You were born or adopted into a family that owned a small business. From a young age you worked alongside your parents, learning to run the business and always understanding that once you reached adulthood it would become your responsibility.

**Skill Proficiencies:** Insight, Persuasion

**Tool Proficiencies:** Either vehicles (land) or vehicles (water), one of your choice

**Equipment:** The deed to your business, a set of common clothes and a belt pouch containing 10 gp

### Feature: Investment Heir

As the heir to your family's business, you begin the game with an investment valued at 100 gold pieces. This could be an entire business, albeit a modest one, or it could be a share of a larger concern. This starting investment can be in any type of business. Work with your DM to determine the appropriate sort of investment for the campaign.

### Suggested Characteristics

How your experiences have helped shape your outlook depends greatly on what sort of business you grew up in. Formative years spent in the depths of a salt mine produces a very different outlook than those spent behind the counter of a jewelry shop. One common characteristic of anyone growing up in a family business is a keen understanding of the importance of profit.

#### d8 Personality Trait

1	My manner of speaking makes it seem as though I'm always trying to sell something.
2	Adventuring is just another sort of business, and I know how to manage a business.

3	I trust a firm handshake more than a fancy contract.
4	I'm often embarrassed that I inherited my business instead of starting it myself.
5	I have a lifetime of experience in what I do and I take great offense when someone questions my judgement on business matters.
6	No one can bargain a deal better than me.
7	I assume everyone wants to hear stories of the big sales I've made and famous customers I've served.
8	I treat everyone like a potential customer, no matter how unlikely the circumstances.

#### d6 Ideal

1	<b>Community.</b> My business is an anchor upon which the lives and well-being of many depend. (Good)
2	<b>Tradition.</b> What we do and how we do it defines our culture, and thus ourselves. (Lawful)
3	<b>Innovation.</b> It doesn't matter what you're doing, there's always a better way to do it. (Chaotic)
4	<b>Profit.</b> At the end of the day, I'm only in this for the money. (Evil)
5	<b>Aspiration.</b> One day, I want to own a business so large it's known all over the world. (Any)
6	<b>Industry.</b> A hard day's work is its own reward. (Lawful)

#### d6 Bond

1	I will take revenge on the thugs who robbed my business.
2	One day I will sell my business and use the money to do something truly worthwhile.
3	To me, my business is like a sacred temple, to be defended at all cost.
4	I had a prior business that failed – and the money lenders are still after me to pay the debts.
5	My employees depend on the wages I pay to provide for their families; if my business fails, I fail them.
6	My parents entrusted their life's work to me and I refuse to disappoint them.

d6	Flaw
1	My inheritance is shared with my siblings and I would gladly betray them to take it all for myself.
2	I value profit more than the well-being of my employees.
3	To keep my business afloat I made a deal with some criminals.
4	I resent my parents for forcing me to be part of their business instead of allowing me to follow my own dreams.
5	I assume everyone is trying to cheat me.
6	My employees don't love me, but they do fear me and I like it that way.

## Feudal and Capitalist Economies

The preceding rules all assume an economy roughly based on the historical feudal economies of the real world. A basic description of this sort of economy is that land is owned by the ruling class (the nobility for example). Common people are

given the right to live and work on the land in exchange for service they provide to the local noble. In addition to their right to live and work the land, the commoners are also granted military protection by the landowner.

For modern readers, who likely live in a capitalist economy where land can be privately owned, much of the feudal economy would seem rather alien. This is no doubt why the settings of most Dungeons & Dragons games, while ostensibly mimicking the medieval period's economics, owe considerably more to contemporary economic sensibilities.

One of the key differences between feudal and capitalist economies is the use of debt. In feudal economies money lending exists, but generally only in relatively small amounts, for relatively short periods of time and for relatively high rates of interest. The notion of borrowing significant sums in order to build a house or start a business is not part of a feudal world.

In order to simulate a capitalist economy, a few alterations need to be made to the above rules





regarding debt: First, it is permissible to borrow money and use it to invest in a business. This debt cannot exceed 50% of the total investment being made, although the total debt can subsequently increase up to the total value of the gross investment if needed to cover losses.

Employing debt to start a business obviously adds somewhat to the challenge of generating a net profit, as the business incurs interest expenses immediately. However, this is offset somewhat by interest rates being generally lower in a capitalist economy. When calculating monthly interest expense, use a rate of 10% instead of 20% to reflect this.

## Magic

The subject of magic hasn't intruded in the preceding rules for two reasons. The first is that the amount of magic present in a campaign varies substantially. Thus, the extent to which magic influences the economy and the practice of running a business also varies from campaign to campaign. The second is that there are simply so many different ways the presence of magic can impact business it's effectively impossible to anticipate all the possibilities.

Many spells have the potential to alter the normal course of commerce. Even if only cantrips are considered, there are spells such as *friends* and *mending* which can respectively swing the outcome of a contract negotiation in favour of the spellcaster and render the efforts of a small army of artisans irrelevant. Higher level spells magnify these effects: *Charm person*, *detect thoughts*, *fabricate* and a plethora of other still more powerful spells can alter many of the basic assumptions that make an economy work. How can one expect to sell something when she can be magically compelled to just give it away? How can one expect to earn a living building things when someone else can cause them to appear with the wave of a hand? For that matter, what good does

it do to hold inventory when spells like *invisibility* and *dimension door* make property rights nothing more than a philosophical concept?

These issues are presented as questions because the answers are not given here. Every Dungeon Master needs to decide for herself the prevalence of magic in her world and what its effects are. Perhaps magic is rare enough that the economy marches on indistinguishable from a world without magic. Or perhaps it's so ubiquitous every business owner must be an accomplished spellcaster with arcane constructs and summoned fiends standing sentry over every transaction or else risk almost immediate bankruptcy. Most campaigns will fall somewhere between the two extremes – just remember that the more magic there is in a setting, the more businesses must be ready to incorporate it into their operations and be prepared to defend against it.

A further consideration is the existence of magic items and the possibility of procuring or even manufacturing them for resale. The official rulebooks provide some guidelines as to the time and resources needed to construct magic items, as well as the potential value to sell them. For the purpose of operating a business using these rules, there should be no need to treat a concern dealing in magical items differently than any other business.

Depending on whether the magic items are purchased for resale or manufactured from scratch, the business would be either resale- or manufacturing-type. Beyond that, all the rules contained herein pertain equally well to a magical business as to a mundane one. Bear in mind that while enchanted items may sell for a premium, so too would they cost a considerable amount to buy or make, hence the return on investment concepts presented in this rules could be used without adjustment.

## Adventure Hooks

Owning and operating a business should integrate the player characters into the campaign setting more fully than the stereotypical gang of “homicidal hobos” that populate most D&D campaigns. At a minimum, the business becomes a home base for the party – somewhere to pass time constructively and hopefully earn some money while waiting for the next adventure. It also provides player characters with something meaningful to do with all that treasure they find.

Ideally, it can be much more than this. Owning a business allows for natural adventure hooks. This concept is strongly tied to the narrative you construct to explain the results of monthly business operations (see *Developing a Narrative for Market Conditions*, page 15). With a minimum of coaxing, a story should begin to emerge that can lead to new adventures in an organic and unexpected way. Remember also that although there are limitations on the sort of management actions a business can take, whether due to time constraints in a month or to culture restrictions, there’s nothing saying an adventuring party can’t take it upon themselves to influence the market environment through their own ingenuity.

Table 6 lists a number of possible business-related adventure hooks, which can be rolled for randomly or used for inspiration.

**Table 6: Adventure Hook Ideas**

d10	Adventure Hook
1	Once prolific resources of a mine, forest or other such site have mysteriously become scarce
2	Shipments to or from the business are being targeted by bandits, and it’s far too frequent to be random
3	Unscrupulous competitors are plotting against the company; their plans include sabotage and worse
4	Customers of the business have been disappearing and the authorities suspect the owner

5	A new noble family has assumed control of the area, and the business is at risk of being outlawed
6	Odd weather has been hampering operations, and the portents say it isn’t natural
7	A protection racket has moved into the area and threatened the business – pay up or else
8	War is brewing: Will it be good for business or a catastrophe?
9	Steep tariffs are cutting into profits and smugglers are offering their services to avoid the onerous levies, but is it worth the risk?
10	A new client is offering a rich contract, but whomever wins it needs to complete a series of bizarre and potentially dangerous tasks



## Business Examples

In order to illustrate the rules presented above, two businesses are exemplified here. The first is relatively straightforward – a smallish service business. The second is a more complex combination business with several owners. Both businesses are described over the course of one or more months of operation to demonstrate the use of random events and management actions.



### Business Example 1: The Emblazoned Escutcheon

Warrior and explorer Adalbern Vigdis honed his skills as a soldier-for-hire before joining a freelance adventuring party. Some time has passed and, with a heavy purse and an eye towards the future, Adalbern is looking to invest some of his earnings. The only sort of business the warrior really knows is soldiering, so he decides to start up a small mercenary company called The Emblazoned Escutcheon.

Adalbern's player, Agnes, confers with her Dungeon Master and they both agree that a mercenary company is properly classified as a service-type business. The risk factor is x1. Being a proponent of new strategies and equipment styles, Adalbern decides that an innovative culture suits his business best. The last piece needed to set the business up is deciding on the initial

investment. In this case, Adalbern decides to start with a 5,000 gold piece investment. At the default construction speed, he needs to wait 34 days before the business is up and running.

At this point Agnes could begin the first month of operations, but elects to spend some time adding more description to the business, giving it a real identity and presence in the campaign. Again conferring with the DM, Agnes decides that a 5,000 gold investment is sufficient to build a small barracks with an adjoining training yard, with enough left over for the working capital needed to finance the first month's payroll and other expenses. The company employs about 30 hired mercenaries (the specific number isn't important, but 30 sounds about right). Since Adalbern has been adventuring in and around Daggerford, that will be the location of the barracks. This mercenary company offers security services as well as occasional military work in border skirmishes and other engagements around the central Sword Coast.

For the first month of operations, Adalbern sticks close to Daggerford so he can be available for management actions. Agnes begins by rolling for market conditions and checks for random events.

For market environment there are no roll modifiers as this is the first month of operating. Agnes rolls 3d6 for each condition, getting '14' for economic (favourable, +1% ROI), '9' for political (neutral), '10' for strife (neutral) and '13' for competition (favourable, +1% ROI). A 1d6 roll for random events comes up '4', no random event this month. So far, so good.

Since Adalbern is spending downtime in the area, he decides to try a management action. As this is an innovative business, it seems natural to try the invention action. The base DC is 30, but since the warrior has nothing else going on, he decides to spend 25 days on the action, reducing the DC to the minimum of 5. Agnes makes her Intelligence ability check with advantage (due to the innovative culture), rolling an '11'. Since she exceeded the DC by 5 or more, this is an

outstanding success and the gross investment of Adalbern's business increases by 4%.

At the end of the first month, the return on investment calculation looks like this:

Return on Investment Calculator	
Base ROI	10%
± Market Environment	+2%
- Accumulated Malfunctions	n/a
- Accumulated Cancelled Contracts	n/a
± Other Random Events	none
± Management Actions	+0%
= Gross ROI	12%
× Risk Factor	1
= Risk-Weighted ROI	12%
× Gross Investment	5,200 gp
+ I2 = Gross ROI	52 gp
- Interest Expense	-
- Contract Labour Expense	-
± Other Adjustments	-
= Net Return on Investment	52 gp

Note that the gross investment is 5,200 rather than 5,000 because the invention action increased it by 4%. Adalbern pockets 52 gold pieces in profits after one month of operation – not too shabby.

At this point Agnes and her DM have the choice of moving on to the next month or spending some time building a narrative for the month's activity. The market conditions aren't unusual enough to be suggestive of any real drama, but it might be interesting to consider what that invention action represents. Perhaps Adalbern spent those 25 days showing his newly-hired mercenaries some of the unorthodox techniques he learned as an adventurer, or perhaps the old warrior has a few tricks to make armour fit better. There are many possibilities, but whatever Agnes decides on should reasonably explain why her little mercenary company is just a bit more valuable now than it was at the beginning of the month.



### Business Example 2: The Orc's Fork Tavern and Flophouse

Adventuring parties are known for frequenting establishments that more genteel company would avoid. The Orc's Fork Tavern and Flophouse is one such place. Despite its decrepit appearance and evil reputation, the place holds a certain fascination for the opportunistic sell-sword trio of Ruaidri, Colman and Donnchad. When the prior owner offered to sell The Orc's Fork for 8,100 gold (6,750 gold investment value plus 20% goodwill premium), the three split the cost and became joint proprietors.

The Fork, as it's commonly known, offers rooms for rent and a kitchen which serves hot meals and lukewarm ales from its location amidst the wharves of Luskan. The trio's players, Marcello, Kalila and Asher, meet with their DM to discuss the type and culture of the business. Offering rooms for rent signifies a service business, but serving meals and drinks is closer to resale or manufacturing. There is the option of splitting the concern up into two or more separate investments, but since all activity takes place in a single building, it makes more sense to keep it a single investment. The DM decides the Fork is a

mixed service/ manufacturing/ resale business, with an averaged risk factor of 3.

Since it's an existing business, the DM chooses its culture, which based on reputation he decides is cut-throat. The player characters could choose to change the culture, but for now cut-throat suits them so they leave it alone (taking a rather expansive view of what constitutes heroic role-playing). The gross investment is equal to the purchase value of 6,750 gold excluding the goodwill premium, with each of the three owners individually holding a 2,250 gold piece share of the total business.

Adventure calls, so the sell-swords leave the Fork in the hands of its staff and promptly leave town. The players elect Kalila to roll for the business' activity. For market environment, she rolls a '17' for economic (propitious, +3% ROI!), a '9' for political (neutral), a '7' for strife (unfavourable, -1% ROI) and a '12' for competition (neutral). Since this business was already operating, the Dungeon Master could have ruled that existing market conditions warranted adjustments to the market environment rolls, but chose not to.

Kalila then rolls for random events – '6', a random event has occurred. She rolls 2d6 and gets a '4', malfunction. This is going to hurt the return on investment, unfortunately. If one or more of the owners were in town, they could try a maintenance management action to repair the malfunction, but since they aren't around there's not much that can be done.

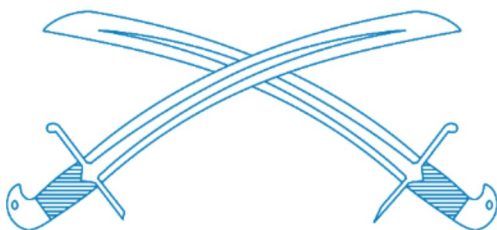

For the first month of operations, the return on investment looks like this:

Return on Investment Calculator	
Base ROI	10%
± Market Environment	+2%
- Accumulated Malfunctions	-5%
- Accumulated Cancelled Contracts	n/a
± Other Random Events	none
± Management Actions	+0%
= Gross ROI	7%
× Risk Factor	3
= Risk-Weighted ROI	21%
× Gross Investment	6,750 gp
± 12 = Gross ROI	118 gp, 1 sp, 2 cp
- Interest Expense	-
- Contract Labour Expense	-
± Other Adjustments	-
= Net Return on Investment	118 gp, 1 sp, 2 cp

The business is profiting, and the owners would split the profit three ways (it won't divide evenly, but hopefully Ruaidri, Colman and Donnchad can come to a friendly agreement on who keeps the extra few coppers). It's worth noting that the money doesn't magically appear in their purses – the business would hold on to it until they make a trip back to town to pick up their earnings.

For the second month's operations, Kalila once again makes all the rolls. She rolls '10' for the economic condition (with a +4 adjustment for the prior propitious state makes it a '14' – favourable, +1% ROI), '8' for political (unfavourable, -1% ROI), '6' for strife (-2 adjustment makes it a '4' – adverse, -3% ROI) and '11' for competition (neutral). The market environment is getting worse, particularly the strife condition.

Rolling for random events, Kalila gets another '6', then a '5' on her 2d6 roll to see which event occurs – yet another malfunction! At this point the owners are worried their new business is falling apart in their absence, so they make their way back to Luskan with enough time left to spend 12 days

performing the maintenance management action before the end of the month.

The DC for the Intelligence ability check is 18 (30 less the 12 days spent). Colman is the smartest of the three owners (or so he says), so he makes the ability check with assistance from Donnchad to give him advantage on the roll. With his Intelligence modifier of -2 ('smartest' is a relative term, after all), Colman's result is an '11'. Unfortunately this is bad enough that the result is a catastrophic failure and the business endures yet another malfunction.

The second month's ROI calculation looks like this:

Return on Investment Calculator	
Base ROI	10%
± Market Environment	-3%
- Accumulated Malfunctions	-15%
- Accumulated Cancelled Contracts	n/a
± Other Random Events	none
± Management Actions	+0%
= Gross ROI	-8%
x Risk Factor	3
= Risk-Weighted ROI	-24%
x Gross Investment	6,750 gp
+ I2 = Gross ROI	-135 gp
- Interest Expense	-
- Contract Labour Expense	-
± Other Adjustments	-
= Net Return on Investment	-135 gp

Having already spent their prior month's earnings, the sell-swords decide to incur debt to cover this month's losses, hoping to pay it off with future profits. They note the debt balance on their business sheet, but interest expense is calculated based on opening debt, not closing, so there is no interest expense this month.

Marcello opts to do the rolling in month three. For the market environment, he rolls '10' for economic (+2 adjustment makes it a '12' – neutral), '9' for political (-2 adjustment drops it to '7' – unfavourable, -1% ROI), '12' for strife (-4

adjustment makes it '8' – unfavourable, -1% ROI) and '11' for competition (neutral). His roll for random events comes up a '2', no random event this month.

Not wanting to repeat last month's maintenance fiasco, the owners decide to bring in a contractor to help. They decide to hire a consultant with a cost of 2 gp/day for 20 days. The maintenance action's ability check is made with the consultant's +2 modifier, with advantage, against a DC of 10. Marcello makes the roll, rolling a '14' with the modifier included. Not an outstanding success, but enough to remove the existing three malfunctions.

For the third month's ROI, the calculation looks like this:

Return on Investment Calculator	
Base ROI	10%
± Market Environment	-2%
- Accumulated Malfunctions	n/a
- Accumulated Cancelled Contracts	n/a
± Other Random Events	none
± Management Actions	+0%
= Gross ROI	8%
x Risk Factor	3
= Risk-Weighted ROI	24%
x Gross Investment	6,750 gp
+ I2 = Gross ROI	135 gp
- Interest Expense	-2 gp, 2 gp, 5 gp
- Contract Labour Expense	-40 gp
± Other Adjustments	-
= Net Return on Investment	92 gp, 7 gp, 5 gp

The 40 gold piece contractor cost ate into the profits, as did the interest expense on the debt balance, but at least the business is back to being profitable.

At this point, the trio decide that life as business owners isn't for them, and so they sell the Fork. To calculate the sales value, they start with the gross investment of 6,750 gold pieces. From that they subtract debt of 135 gold. Lastly they determine goodwill: Year-to-date profits total 75 gold, 8 silver

and 7 copper. Divided by three (the number of months in business so far this year) and multiplied by 12 gives an annualized profit of 303 gold, 4 silver and 8 copper. Multiplied by 2 yields a goodwill value of 606 gold, 9 silver and 6 copper. The total sales value is 7,221 gold, 9 silver and 6 copper.

Throughout the three months of business operations, more flavour could be added to the events if the players and their DM wish. What specifically caused those malfunctions? Was it a faulty stove, a leaky roof, a cockroach infestation? The strife condition was also detrimental, was that due to calm weather keeping ships out to sea and their crews away from the Fork's tap house, or some other cause? These sorts of narrative additions aren't necessary, but do use them if they're fun or if they lead to unexpected drama and adventure.



# The Business Sheet

The following sheet or a variation of it can be used to track the details and performance of a business.

Business Sheet			
Business Name <input style="width: 90%;" type="text"/>	Location <input style="width: 90%;" type="text"/>		
Type <input style="width: 90%;" type="text"/>	Description and History of the Business <div style="border: 1px solid black; height: 100px;"></div>		
Risk Factor <input style="width: 90%;" type="text"/>			
Culture <input style="width: 90%;" type="text"/>			
Gross Investment <input style="width: 90%;" type="text"/>			
Owner #1 <input style="width: 20%;" type="text"/> Investment Share <input style="width: 20%;" type="text"/>			
Owner #2 <input style="width: 20%;" type="text"/> Investment Share <input style="width: 20%;" type="text"/>			
Owner #3 <input style="width: 20%;" type="text"/> Investment Share <input style="width: 20%;" type="text"/>			
Owner #4 <input style="width: 20%;" type="text"/> Investment Share <input style="width: 20%;" type="text"/>			
<b>Market Environment</b>		<b>Return on Investment Calculator</b>	
	Prior Month	Current Month	ROI Impact
Economic	<input style="width: 80%;" type="text"/>	<input style="width: 80%;" type="text"/>	<input style="width: 80%;" type="text"/>
Political	<input style="width: 80%;" type="text"/>	<input style="width: 80%;" type="text"/>	<input style="width: 80%;" type="text"/>
Strife	<input style="width: 80%;" type="text"/>	<input style="width: 80%;" type="text"/>	<input style="width: 80%;" type="text"/>
Competition	<input style="width: 80%;" type="text"/>	<input style="width: 80%;" type="text"/>	<input style="width: 80%;" type="text"/>
<b>Random Events</b>		<b>Return on Investment Calculator</b>	
	Current Month	ROI Impact	
Current Month	<input style="width: 80%;" type="text"/>	<input style="width: 80%;" type="text"/>	
Malfunctions	<input style="width: 80%;" type="text"/>	<input style="width: 80%;" type="text"/>	
Cancelled Contracts	<input style="width: 80%;" type="text"/>	<input style="width: 80%;" type="text"/>	
<b>Management Actions</b>		<b>Return on Investment Calculator</b>	
	Management Actions	ROI Impact	
	<input style="width: 80%;" type="text"/>	<input style="width: 80%;" type="text"/>	
Debt	<input style="width: 80%;" type="text"/>	<b>Year to Date Profit/(Loss)</b>	
Interest Expense	<input style="width: 80%;" type="text"/>		
Contract Labour Expense	<input style="width: 80%;" type="text"/>		
Notes	<input style="width: 80%;" type="text"/>		



## Legal

---

A Going Concern ©2017 Paul Daniel Johnson.

DUNGEONS & DRAGONS, D&D, Wizards of the Coast, Forgotten Realms, the dragon ampersand, Player's Handbook, Monster Manual, Dungeon Master's Guide, D&D Adventurers League, all other Wizards of the Coast product names, and their respective logos are trademarks of Wizards of the Coast in the USA and other countries. All characters and their distinctive likenesses are property of Wizards of the Coast. This material is protected under the copyright laws of the United States of America. Any reproduction or unauthorized use of the material or artwork contained herein is prohibited without the express written permission of Wizards of the Coast.

©2016 Wizards of the Coast LLC, PO Box 707, Renton, WA 98057-0707, USA. Manufactured by Hasbro SA, Rue Emile-Boéchat 31, 2800 Delémont, CH. Represented by Hasbro Europe, 4 The Square, Stockley Park, Uxbridge, Middlesex, UB11 1ET, UK.